



ST3243

3 TO 5.5V, 400KBPS, RS-232 TRANSCEIVER WITH AUTO-POWERDOWN

- 1 μ A SUPPLY CURRENT ACHIEVED WHEN IN AUTO-POWERDOWN
- 250Kbps MINIMUM GUARANTEED DATA RATE
- GUARANTEED 6V/ μ s SLEW RATE RANGE
- GUARANTEED MOUSE DRIVEABILITY
- 0.1 μ F EXTERNAL CAPACITORS
- MEET EIA/TIA-232 SPECIFICATIONS DOWN TO 3V
- AVAILABLE IN SO-28, SSOP-28 AND TSSOP28

DESCRIPTION

The ST3243 device consists of 3 drivers, 5 receivers and a dual charge-pump circuit. The device meets the requirements of EIA/TIA and V.28/V.24 communication standards providing high data rate capability.

The receiver R2 is always active to implement a wake-up feature for serial port.

The ST3243 has a proprietary low-dropout transmitter output stage enabling true RS-232 performance from a 3.0V to 5.5V supply with a dual charge pump. The device is guaranteed to run at data rates of 250kbps while maintaining RS-232 output levels.

The Auto-powerdown feature functions when FORCEON is low and FORCEOFF is high. During this mode of operation, if the device does not sense a valid RS-232 signal, the driver outputs are disabled. If FORCEOFF is set low, both drivers and receivers (except R2B) are shut off, and supply current is reduced to 1mA. Disconnecting

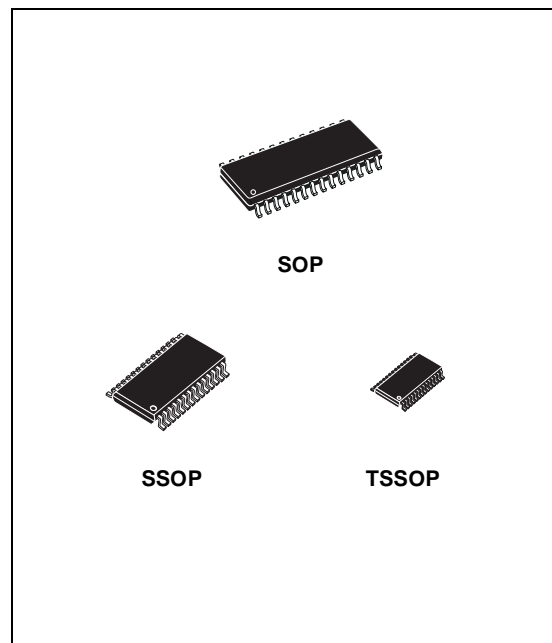

the serial port or turning off the peripheral drives causes the auto-powerdown condition to occur. Auto-powerdown can be disabled when FORCEON and FORCEOFF are high, and should be done when driving a serial mouse. With Auto-powerdown enabled, the device is activated automatically when a valid signal is applied to any receiver input.

Typical application are in notebook, subnotebook, palmtop computers, battery-powered equipment, hand-held equipment, peripherals and printers.

ST3243

ORDERING CODES

Type	Temperature Range	Package	Comments
ST3243CD	0 to 70 °C	SO-28 (Tube)	27parts per tube / 12tube per box
ST3243BD	-40 to 85 °C	SO-28 (Tube)	27parts per tube / 12tube per box
ST3243CDR	0 to 70 °C	SO-28 (Tape & Reel)	1000 parts per reel
ST3243BDR	-40 to 85 °C	SO-28 (Tape & Reel)	1000 parts per reel
ST3243CPR	0 to 70 °C	SSOP-28 (Tape & Reel)	1350 parts per reel
ST3243BPR	-40 to 85 °C	SSOP-28 (Tape & Reel)	1350 parts per reel
ST3243CTR	0 to 70 °C	TSSOP28 (Tape & Reel)	2500 parts per reel
ST3243BTR	-40 to 85 °C	TSSOP28 (Tape & Reel)	2500 parts per reel

PIN DESCRIPTION

PIN N°	SYMBOL	NAME AND FUNCTION
1	C ₂₊	Positive Terminal of Inverting Charge Pump Capacitor
2	C ₂₋	Negative Terminal of Inverting Charge Pump Capacitor
3	V-	-5.5V Generated by the Charge Pump
4	R _{1IN}	First Receiver Input Voltage
5	R _{2IN}	Second Receiver Input Voltage
6	R _{3IN}	Third Receiver Input Voltage
7	R _{4IN}	Fourth Receiver Input Voltage
8	R _{5IN}	Fifth Receiver Input Voltage
9	T _{1OUT}	First Transmitter Output Voltage
10	T _{2OUT}	Second Transmitter Output Voltage
11	T _{3OUT}	Third Transmitter Output Voltage
12	T _{3IN}	Third Transmitter Input Voltage
13	T _{2IN}	Second Transmitter Input Voltage
14	T _{1IN}	First Transmitter Input Voltage
15	R _{5OUT}	Fifth Receiver Output Voltage
16	R _{4OUT}	Fourth Receiver Output Voltage
17	R _{3OUT}	Third Receiver Output Voltage
18	R _{2OUT}	Second Receiver Output Voltage
19	R _{1OUT}	First Receiver Output Voltage
20	R _{2OUTB}	Non-inverting Complementary Receiver Output, always active for wake-up
21	INVALID	Output of the valid signal detector. Indicates if a valid RS-232 level is present on receiver inputs logic "1"
22	FORCEOFF	Drive low to shut down transmitters and on-board power supply. This over-rides all automatic circuitry and FORCEON
23	FORCEON	Drive high to override automatic circuitry keeping transmitters on (FORCEOFF must be high)
24	C ₁₋	Negative Terminal of Voltage- Charge Pump Capacitor
25	GND	Ground
26	V _{CC}	Supply Voltage
27	V+	5.5V Generated by the Charge Pump
28	C ₁₊	Positive Terminal of Voltage- Charge Pump Capacitor

PIN CONFIGURATION

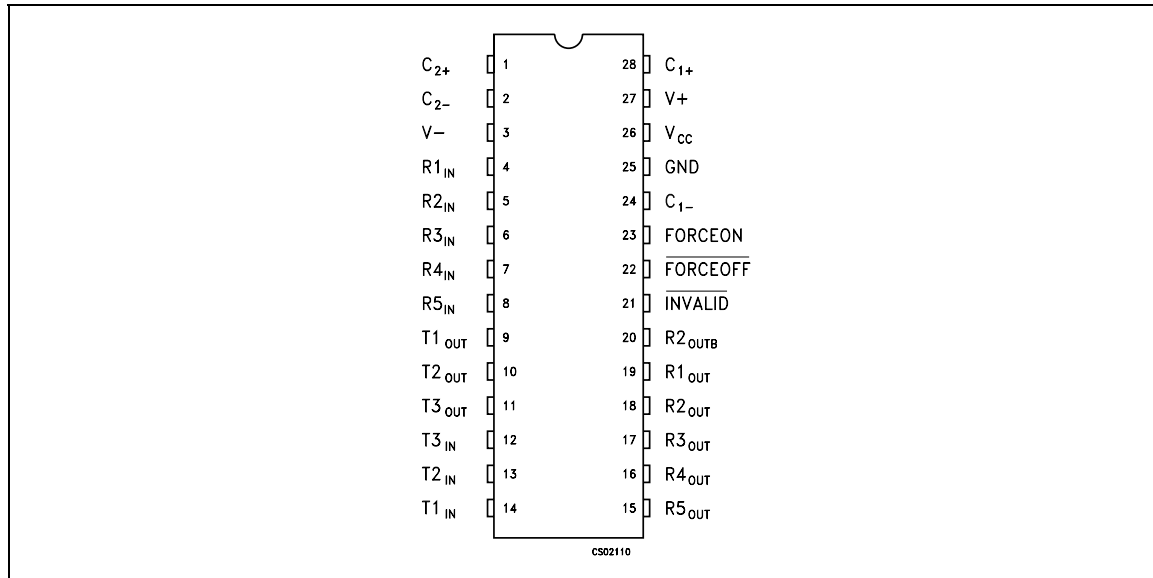

TRUTH TABLE

FORCE OFF	T _{OUT}	R _{OUT}	R _{2OUTB}
0	HIGH Z	HIGH Z	ACTIVE *
1	ACTIVE *	ACTIVE *	ACTIVE *

* If the part is in auto-powerdown mode (FORCE OFF = V_{CC}, FORCE ON = GND) it is shutdown, if no valid RS-232 levels are present on all receiver input

ABSOLUTE MAXIMUM RATINGS

Symbol	Parameter	Value	Unit
V _{CC}	Supply Voltage	-0.3 to 6	V
V+	Doubled Voltage Terminal	(V _{CC} - 0.3) to 7	V
V-	Inverted Voltage Terminal	0.3 to -7	V
V+ + V-		13	V
FORCEON, FORCEOFF, T _{IN}	Input Voltage	-0.3 to 6	V
R _{IN}	Receiver Input Voltage Range	± 25	V
T _{OUT}	Transmitter Output Voltage Range	± 13.2	V
R _{OUT} R _{OUTB} INVALID	Receiver Output Voltage Range	-0.3 to (V _{CC} + 0.3)	V
t _{SHORT}	Short Circuit Duration on T _{OUT} (one at a time)	Continuous	
T _{stg}	Storage Temperature Range	-65 to 150	°C

Absolute Maximum Ratings are those values beyond which damage to the device may occur. Functional operation under these condition is not implied. V+ and V- can have a maximum magnitude of +7V, but their absolute addition can not exceed 13 V.

(*) The device doesn't meet 1KV ESD HBM

ELECTRICAL CHARACTERISTICS(C₁ - C₄ = 0.1μF, V_{CC} = 3V to 5.5V, T_A = -40 to 85°C, unless otherwise specified.)Typical values are referred to T_A = 25°C)

Symbol	Parameter	Test Conditions	Min.	Typ.	Max.	Unit
I _{ASHDN}	Supply Current Auto-powerdown	V _{CC} = 3.3 or 5.0V All R_IN open T _A = 25°C FORCEOFF = V _{CC}		1	10	μA
I _{SHDN}	Shutdown Supply Current	V _{CC} = 3.3 or 5.0V All R_IN open T _A = 25°C FORCEOFF = GND		1	10	μA
I _{SHDN}	Supply Current Auto-powerdown Disabled	V _{CC} = 3.3 or 5.0V T _A = 25°C FORCEON = FORCEOFF = V _{CC} No Load		0.3	1	mA

LOGIC INPUT ELECTRICAL CHARACTERISTICS(C₁ - C₄ = 0.1μF, V_{CC} = 3V to 5.5V, T_A = -40 to 85°C, unless otherwise specified.)Typical values are referred to T_A = 25°C)

Symbol	Parameter	Test Conditions	Min.	Typ.	Max.	Unit
V _{TIL}	Input Logic Threshold Low	T-IN, FORCEON, FORCEOFF			0.8	V
V _{TIH}	Input Logic Threshold High	T-IN, FORCEON, FORCEOFF V _{CC} = 3.3V V _{CC} = 5V	2 2.4			V V
V _{THYS}	Transmitter Input Hysteresis			0.5		V
I _{IL}	Input Leakage Current	T-IN, FORCEON, FORCEOFF		± 0.01	± 1.0	μA
I _{OL}	Output Leakage Current	Receiver Disabled		± 0.05	± 10	μA
V _{OL}	Output Voltage Low	I _{OUT} = 1.6mA			0.4	V
V _{OH}	Output Voltage High	I _{OUT} = -1mA	V _{CC} -0.6	V _{CC} -0.1		V

AUTO-POWERDOWN ELECTRICAL CHARACTERISTICS(C₁ - C₄ = 0.1μF, V_{CC} = 3V to 5.5V, T_A = -40 to 85°C, unless otherwise specified.)Typical values are referred to T_A = 25°C)

Symbol	Parameter	Test Conditions	Min.	Typ.	Max.	Unit
V _{RITE}	Receiver Input Threshold to Transmitter Enabled	Positive Threshold Negative Threshold	2.7		2.7	V V
V _{RITD}	Receiver Input Threshold to Transmitter Disabled	1μA Supply Current	-0.3		0.3	V
V _{IOLOW}	INVALID Output Voltage LOW				0.4	V
V _{IOHIGH}	INVALID Output Voltage HIGH		V _{CC} -0.6			V
t _{WU}	Receiver Threshold to Transmitter Enabled	I _{OUT} = 1.6mA		250		μs
t _{invh}	Receiver Positive or Negative Threshold to INVALID HIGH	I _{OUT} = -1mA		1		μs
t _{invL}	Receiver Positive or Negative Threshold to INVALID LOW			30		μs

TRANSMITTER ELECTRICAL CHARACTERISTICS(C₁ - C₄ = 0.1μF, V_{CC} = 3V to 5.5V, T_A = -40 to 85°C, unless otherwise specified.Typical values are referred to T_A = 25°C)

Symbol	Parameter	Test Conditions	Min.	Typ.	Max.	Unit
V _{TOUT}	Output Voltage Swing	All Transmitter outputs are loaded with 3KΩ to GND	± 5	± 5.4		V
R _{OUT}	Output Resistance	V _{CC} = V+ = V- = 0V V _{OUT} = ± 2V	300	10M		Ω
I _{SC}	Output Short Circuit Current			± 35	± 60	mA
V _{OT}	Transmitter Output Voltage	T1IN = T2IN = GND, T3IN = V _{CC} T3OUT loaded with 3KΩ to GND T1OUT and T2OUT loaded with 2.5mA each	± 5			V

RECEIVER ELECTRICAL CHARACTERISTICS(C₁ - C₄ = 0.1μF, V_{CC} = 3V to 5.5V, T_A = -40 to 85°C, unless otherwise specified.Typical values are referred to T_A = 25°C)

Symbol	Parameter	Test Conditions	Min.	Typ.	Max.	Unit
V _{RIN}	Receiver Input Voltage Operating Range		-25		25	V
V _{RIL}	RS-232 Input Threshold Low	T _A = 25°C V _{CC} = 3.3V T _A = 25°C V _{CC} = 5.0V	0.6 0.8	1.2 1.2		V
V _{RIH}	RS-232 Input Threshold High	T _A = 25°C V _{CC} = 3.3V T _A = 25°C V _{CC} = 5.0V		1.5 1.8	2.4 2.4	V
V _{RIHYS}	Input Hysteresis			0.5		V
R _{RIN}	Input Resistance	T _A = 25°C	3	5	7	KΩ

TIMING CHARACTERISTICS(C₁ - C₄ = 0.1μF, V_{CC} = 3V to 5.5V, T_A = -40 to 85°C, unless otherwise specified.Typical values are referred to T_A = 25°C)

Symbol	Parameter	Test Conditions	Min.	Typ.	Max.	Unit
D _R	Maximum Data Rate	R _L = 3KΩ C _L = 1000pF one transmitter switching	250	400		Kbps
t _{PHL} t _{PLH}	Receiver Propagation Delay	R _{IN} to R _{OUT} C _L = 150pF		0.15		μs
t _{T_SKEW}	Transmitter Skew			100		ns
t _{R_SKEW}	Receiver Skew			50		ns
t _{INVH}	Receiver Positive or negative Threshold to INVALID HIGH			1		μs
t _{INVL}	Receiver Positive or negative Threshold to INVALID LOW			30		μs
S _{RT}	Transition Slew Rate	T _A = 25°C R _L = 3K to 7KΩ V _{CC} = 3.3V measured from +3V to -3V or -3V to +3V C _L = 150pF to 1000pF C _L = 150pF to 2500pF	6 4		30 30	V/μs V/μs

APPLICATION CIRCUITS

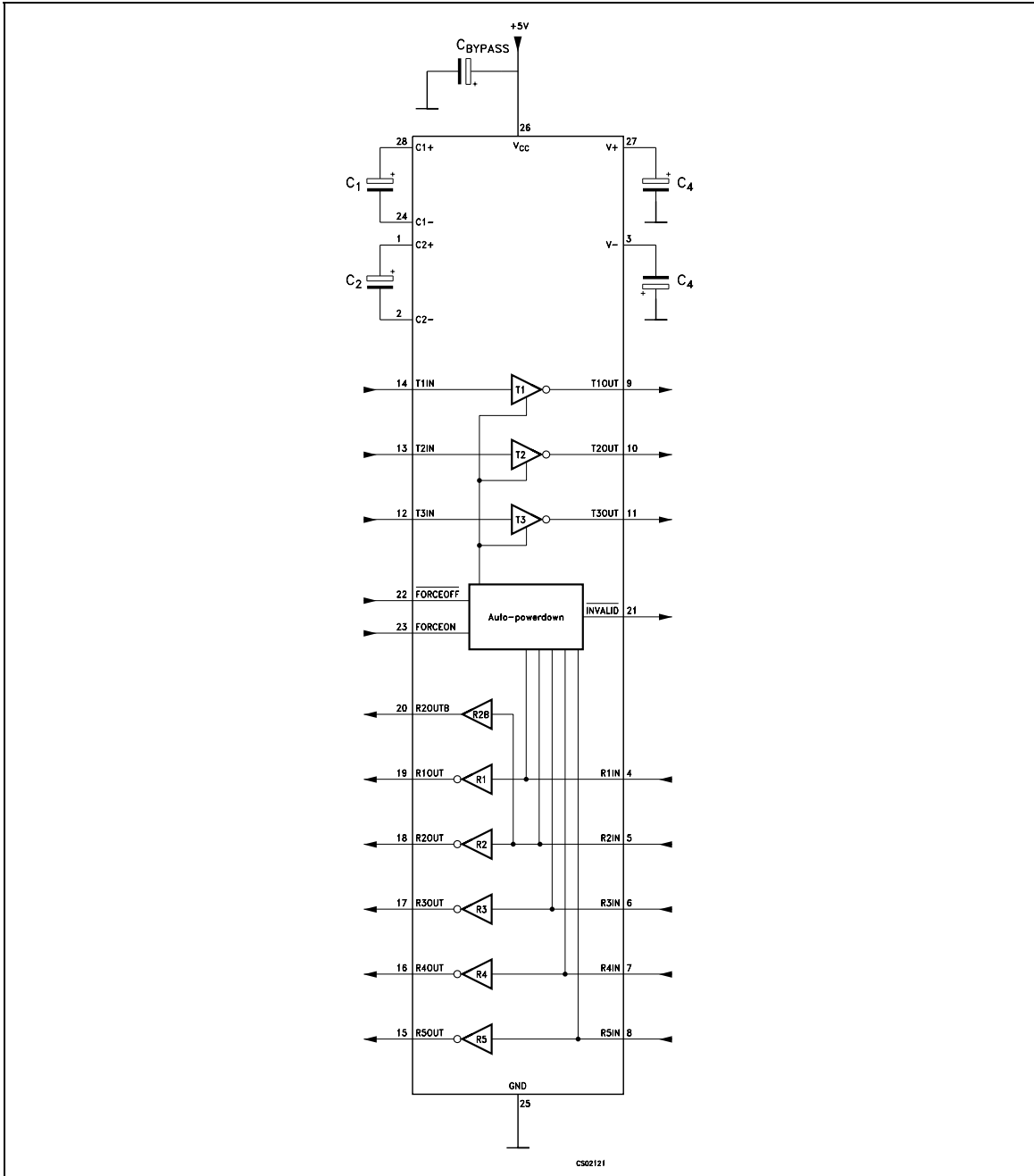

CAPACITANCE VALUE (μF)

V _{CC}	C1	C2	C3	C4	C _{bypass}
3.0 to 3.6	0.1	0.1	0.1	0.1	0.1
4.5 to 5.5	0.047	0.33	0.33	0.33	0.33
3.0 to 5.5	0.22	1.0	1.0	1.0	0.22

TYPICAL PERFORMANCE CHARACTERISTICS (unless otherwise specified $T_j = 25^\circ\text{C}$)

Figure 1 : INVALID HIGH Threshold Time

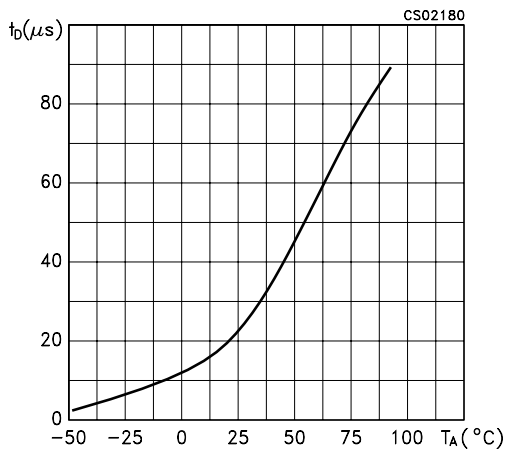

Figure 2 : INVALID LOW Threshold Time

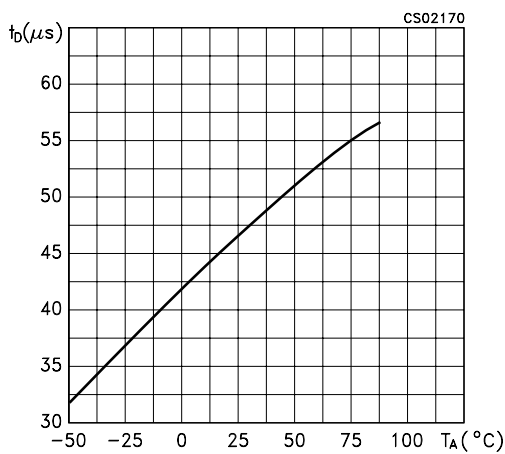

Figure 3 : Receiver Propagation Delay

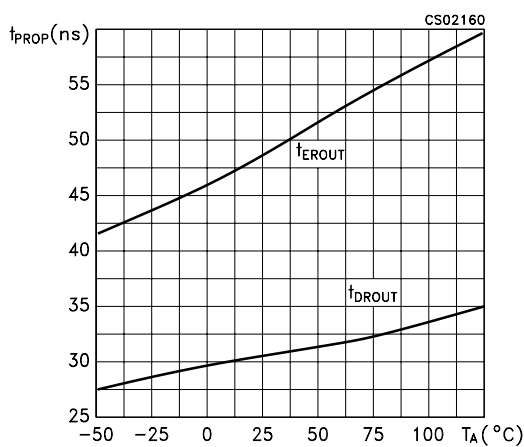

Figure 4 : TReceiver Output Enable & Disable Time

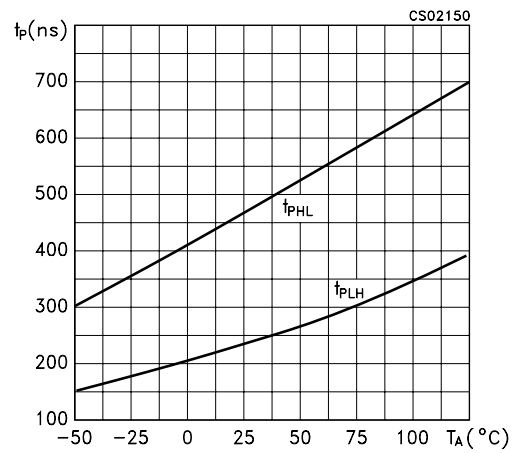

Figure 5 : Output Current vs Output High Voltage

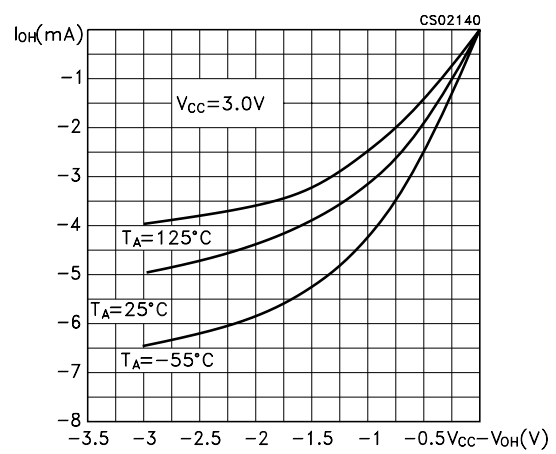
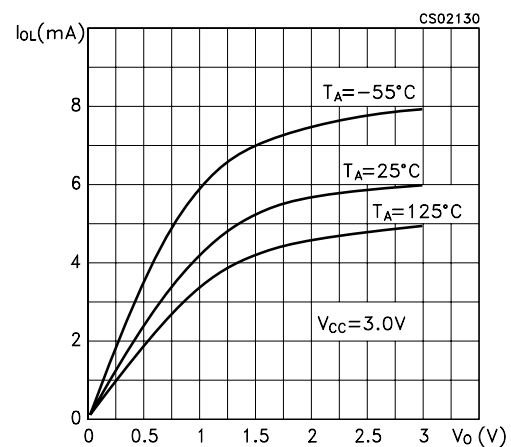
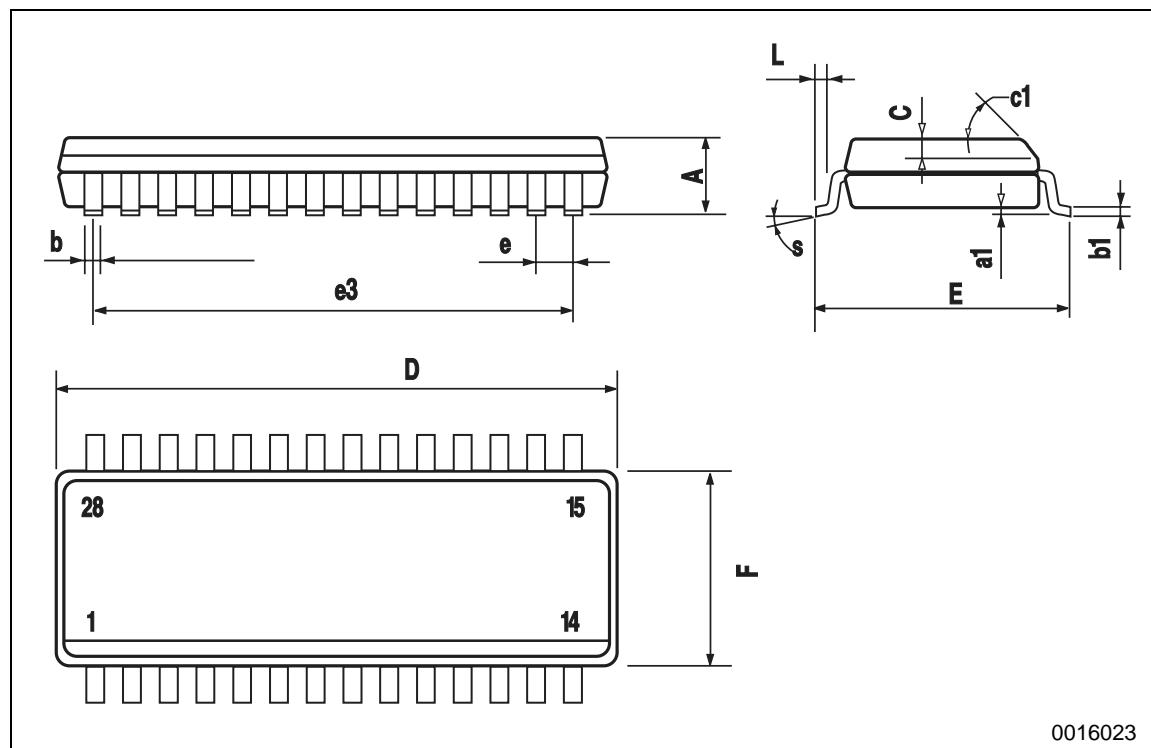

Figure 6 : Output Current vs Output Low Voltage



SO-28 MECHANICAL DATA

DIM.	mm.			inch		
	MIN.	TYP	MAX.	MIN.	TYP.	MAX.
A			2.65			0.104
a1	0.1		0.3	0.004		0.012
b	0.35		0.49	0.014		0.019
b1	0.23		0.32	0.009		0.012
C		0.5			0.020	
c1	45° (typ.)					
D	17.70		18.10	0.697		0.713
E	10.00		10.65	0.393		0.419
e		1.27			0.050	
e3		16.51			0.650	
F	7.40		7.60	0.291		0.300
L	0.50		1.27	0.020		0.050
S	8° (max.)					



SSOP28 MECHANICAL DATA

DIM.	mm.			inch		
	MIN.	TYP	MAX.	MIN.	TYP.	MAX.
A			2			0.079
A1	0.050			0.002		
A2	1.65	1.75	1.85	0.065	0.069	0.073
b	0.22		0.38	0.009		0.015
c	0.09		0.25	0.004		0.010
D	9.9	10.2	10.5	0.390	0.402	0.413
E	7.4	7.8	8.2	0.291	0.307	0.323
E1	5	5.3	5.6	0.197	0.209	0.220
e		0.65 BSC			0.0256 BSC	
K	0°		10°	0°		10°
L	0.55	0.75	0.95	0.022	0.030	0.037

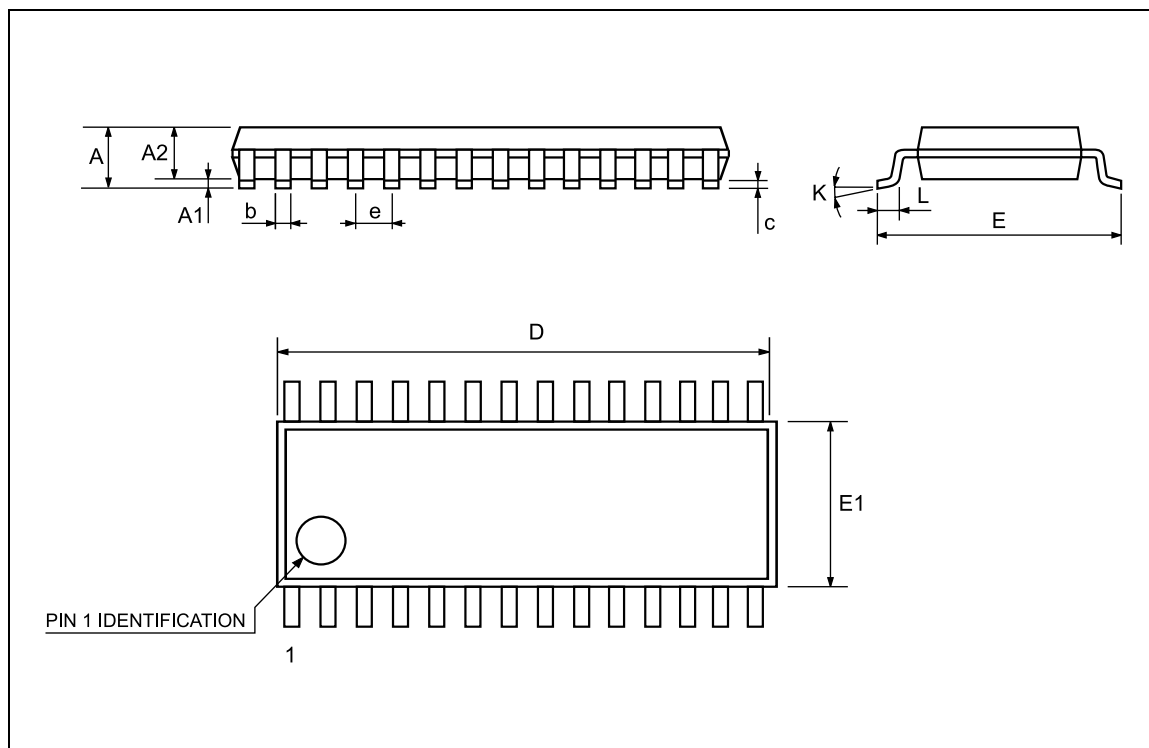

TSSOP28 MECHANICAL DATA

DIM.	mm.			inch		
	MIN.	TYP	MAX.	MIN.	TYP.	MAX.
A			1.2			0.047
A1	0.05		0.15	0.002	0.004	0.006
A2	0.8	1	1.05	0.031	0.039	0.041
b	0.19		0.30	0.007		0.012
c	0.09		0.20	0.004		0.0089
D	9.6	9.7	9.8	0.378	0.382	0.386
E	6.2	6.4	6.6	0.244	0.252	0.260
E1	4.3	4.4	4.48	0.169	0.173	0.176
e		0.65 BSC			0.0256 BSC	
K	0°		8°	0°		8°
L	0.45	0.60	0.75	0.018	0.024	0.030

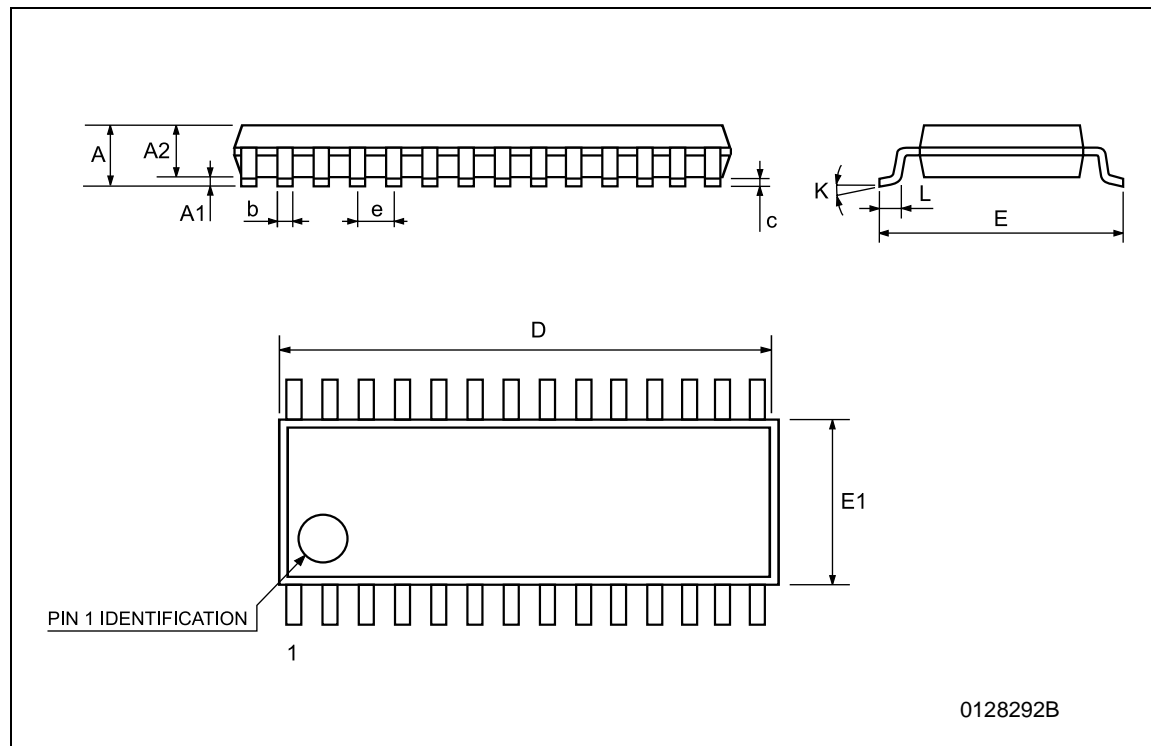

Information furnished is believed to be accurate and reliable. However, STMicroelectronics assumes no responsibility for the consequences of use of such information nor for any infringement of patents or other rights of third parties which may result from its use. No license is granted by implication or otherwise under any patent or patent rights of STMicroelectronics. Specifications mentioned in this publication are subject to change without notice. This publication supersedes and replaces all information previously supplied. STMicroelectronics products are not authorized for use as critical components in life support devices or systems without express written approval of STMicroelectronics.

© The ST logo is a registered trademark of STMicroelectronics

© 2002 STMicroelectronics - Printed in Italy - All Rights Reserved
STMicroelectronics GROUP OF COMPANIES

Australia - Brazil - Canada - China - Finland - France - Germany - Hong Kong - India - Israel - Italy - Japan - Malaysia - Malta - Morocco
Singapore - Spain - Sweden - Switzerland - United Kingdom - United States.

© <http://www.st.com>

