



ST3237

3 TO 5.5V, 250KBPS, RS-232 TRANSCEIVER WITH STAND-BY

- 1 μ A LOW POWER SHUTDOWN WITH RECEIVERS ACTIVE
- GUARENTEED DATA RATE
250Kbps (Normal Operation)
1Mbps (Very High Speed Operation)
- GUARANTEED SLEW RATE RANGE
6V/ μ s (Normal Operation)
24V/ μ s (Very High Speed Operation)
- 0.1 μ F EXTERNAL CAPACITORS
- FLOW-THROUGH PINOUT
- 500 μ A LOW SUPPLY CURRENT
- MEET EIA/TIA-232 SPECIFICATIONS DOWN TO 3V
- AVAILABLE IN SO-28, SSOP-28 AND TSSOP28

DESCRIPTION

The ST3237 is a 3V to 5.5V powered EIA/TIA-232 and V.28/V.24 communication interfaces high data-rate capabilities. ST3237 is a transceiver (5 drivers, 3 receivers) for fast modem applications. The device has a proprietary low-dropout transmitter output stage providing true RS-232 performance from a 3V to 5.5V supply using a dual charge pump. The device is guaranteed to run at data rates of 250Kbps in the normal

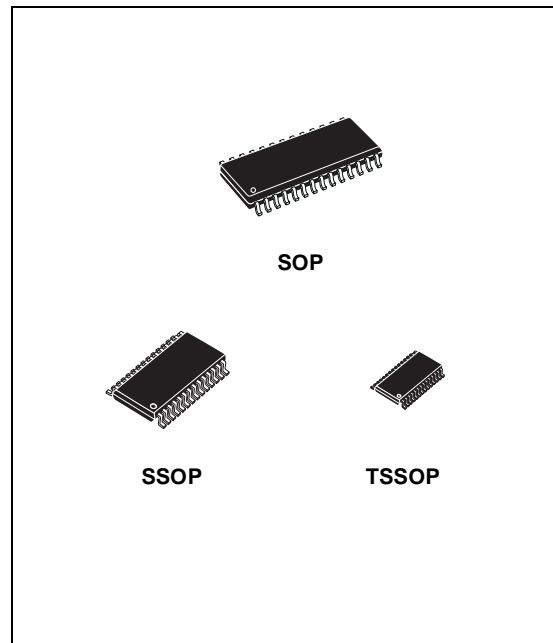

operation mode and 1Mbps in the very high speed operation mode while maintaining RS-232 output levels.

ORDERING CODES

Type	Temperature Range	Package	Comments
ST3237CD	0 to 70 °C	SO-28 (Tube)	27parts per tube / 12tube per box
ST3237BD	-40 to 85 °C	SO-28 (Tube)	27parts per tube / 12tube per box
ST3237CDR	0 to 70 °C	SO-28 (Tape & Reel)	1000 parts per reel
ST3237BDR	-40 to 85 °C	SO-28 (Tape & Reel)	1000 parts per reel
ST3237CPR	0 to 70 °C	SSOP-28 (Tape & Reel)	1350 parts per reel
ST3237BPR	-40 to 85 °C	SSOP-28 (Tape & Reel)	1350 parts per reel
ST3237CTR (*)	0 to 70 °C	TSSOP28 (Tape & Reel)	2500 parts per reel
ST3237BTR (*)	-40 to 85 °C	TSSOP28 (Tape & Reel)	2500 parts per reel

(*) Available on request

PIN DESCRIPTION

PIN N°	SYMBOL	NAME AND FUNCTION
1	C ₂₊	Positive Terminal of Inverting Charge Pump Capacitor
2	GND	Ground
3	C ₂₋	Negative Terminal of Inverting Charge Pump Capacitor
4	V-	5.5V Generated by the Charge Pump
5	T1 _{OUT}	First Transmitter Output Voltage
6	T2 _{OUT}	Second Transmitter Output Voltage
7	T3 _{OUT}	Third Transmitter Output Voltage
8	R1 _{IN}	First Receiver Input Voltage
9	R2 _{IN}	Second Receiver Input Voltage
10	T4 _{OUT}	Fourth Transmitter Output Voltage
11	R3 _{IN}	Third Receiver Input Voltage
12	T5 _{OUT}	Fifth Transmitter Output Voltage
13	EN	Receiver Enable, Active Low
14	SHDN	Shutdown Control, Active Low
15	VHSCI	Very High Speed Control Input. Connect to GND for normal operation; connect to VCC for 1Mbps transmission rates.
16	R1 _{OUTB}	Non Inverting Complementary Receiver Output. Always Active.
17	T5 _{IN}	Fifth Transmitter Input Voltage
18	R3 _{OUT}	Third Receiver Output Voltage
19	T4 _{IN}	Fourth Transmitter Input Voltage
20	R2 _{OUT}	Second Receiver Output Voltage
21	R1 _{OUT}	First Receiver Output Voltage
22	T3 _{IN}	Third Transmitter Input Voltage
23	T2 _{IN}	Second Transmitter Input Voltage
24	T1 _N	First Transmitter Input Voltage
25	C ₁₋	Negative Terminal of Voltage- Charge Pump Capacitor
26	V _{CC}	Supply Voltage
27	V+	-5.5V Generated by the Charge Pump
28	C ₁₊	Positive Terminal of Voltage- Charge Pump Capacitor

PIN CONFIGURATION

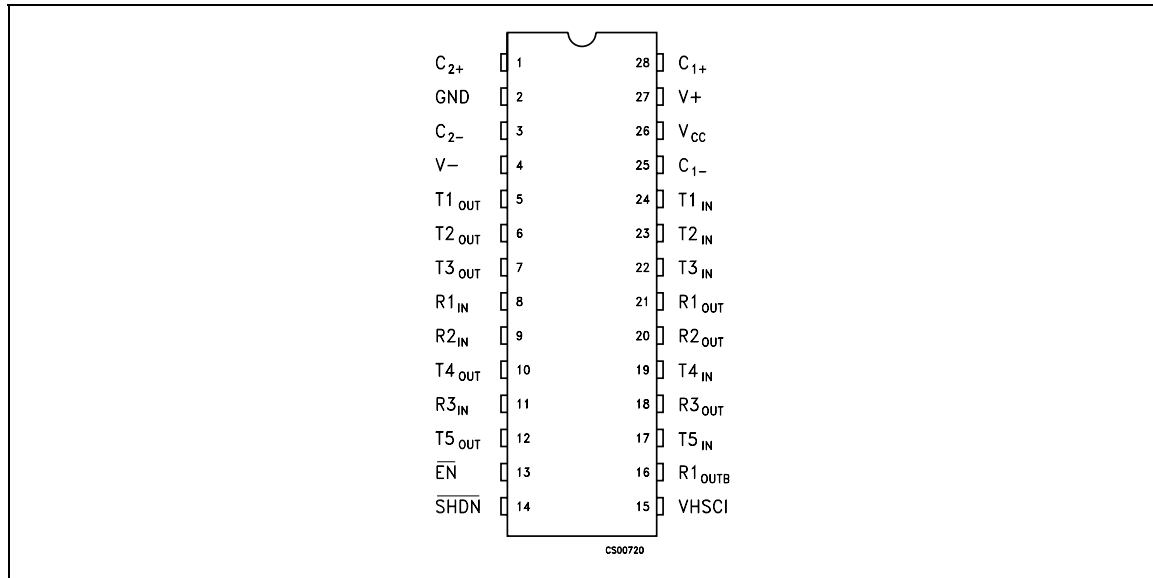

ABSOLUTE MAXIMUM RATINGS

Symbol	Parameter	Value	Unit
V_{CC}	Supply Voltage	-0.3 to 6	V
V+	Doubled Voltage Terminal	-0.3 to 7	V
V-	Inverted Voltage Terminal	0.3 to -7	V
$V+ + V- $		13	V
T_{IN}	Transmitter Input Voltage Range	-0.3 to 6	V
SHDN, EN		-0.3 to 6	V
VHSCI	Very High Speed Control Input	-0.3 to ($V_{CC} + 0.3$)	V
R_{IN}	Receiver Input Voltage Range	± 25	V
T_{OUT}	Transmitter Output Voltage Range	± 13.2	V
R_{OUT} R_{OUTB}	Receiver Output Voltage Range	-0.3 to ($V_{CC} + 0.3$)	V
t_{SHORT}	Short Circuit Duration on T_{OUT} (one at a time)	Continuous	
T_{stg}	Storage Temperature Range	-65 to 150	°C

Absolute Maximum Ratings are those values beyond which damage to the device may occur. Functional operation under these conditions is not implied. V+ and V- can have a maximum magnitude of +7V, but their absolute addition can not exceed 13 V.

ELECTRICAL CHARACTERISTICS(C₁ - C₄ = 0.1μF, V_{CC} = 3V to 5.5V, T_A = -40 to 85°C, unless otherwise specified.Typical values are referred to T_A = 25°C)

Symbol	Parameter	Test Conditions	Min.	Typ.	Max.	Unit
I _{SUPPLY}	V _{CC} Power Supply Current	No Load V _{CC} = 3V or 5.0V T _A = 25°C		0.5	2	mA
I _{SHDN}	Shutdown Supply Current	SHDN=GND T _A = 25°C		1	10	μA

LOGIC INPUT ELECTRICAL CHARACTERISTICS(C₁ - C₄ = 0.1μF, V_{CC} = 3V to 5.5V, T_A = -40 to 85°C, unless otherwise specified.Typical values are referred to T_A = 25°C)

Symbol	Parameter	Test Conditions	Min.	Typ.	Max.	Unit
V _{TIL}	Input Logic Threshold Low (Note 1)	T-IN, VHSCI, EN, SHDN			0.8	V
V _{TIH}	Input Logic Threshold High (Note 1)	V _{CC} = 3.3V V _{CC} = 5V	2 2.4			V V
I _{IL}	Input Leakage Current	T-IN, VHSCI, EN, SHDN		± 0.01	± 1.0	μA
I _{OL}	Output Leakage Current	Receiver Disabled		± 0.05	± 10	μA
V _{OL}	Output Voltage Low	I _{OUT} = 1.6mA			0.4	V
V _{OH}	Output Voltage High	I _{OUT} = -1mA	V _{CC} -0.6	V _{CC} -0.1		V

Note 1: Transmitter input hysteresis is typically 250mV

TRANSMITTER ELECTRICAL CHARACTERISTICS(C₁ - C₄ = 0.1μF tested at 3.3V±10%, V_{CC} = 3V to 5.5V, T_A = -40 to 85°C, unless otherwise specified.Typical values are referred to T_A = 25°C)

Symbol	Parameter	Test Conditions	Min.	Typ.	Max.	Unit
V _{TOUT}	Output Voltage Swing	All Transmitter outputs are loaded with 3KΩ to GND	± 5	± 5.4		V
R _{TOUT}	Transmitter Output Resistance	V _{CC} = V+ = V- = 0V V _{OUT} = ± 2V		3000		Ω
I _{SC}	Output Short Circuit Current			± 25	± 60	mA

RECEIVER ELECTRICAL CHARACTERISTICS(C₁ - C₄ = 0.1μF tested at 3.3V±10%, V_{CC} = 3V to 5.5V, T_A = -40 to 85°C, unless otherwise specified.Typical values are referred to T_A = 25°C)

Symbol	Parameter	Test Conditions	Min.	Typ.	Max.	Unit
V _{RIN}	Receiver Input Voltage Operating Range		-25		25	V
V _{RIL}	RS-232 Input Threshold Low	T _A = 25°C V _{CC} = 3.3V T _A = 25°C V _{CC} = 5V	0.6 0.8	1.2 1.5		V V
V _{RIH}	RS-232 Input Threshold High	T _A = 25°C V _{CC} = 3.3V T _A = 25°C V _{CC} = 5V		1.5 1.8	2.4 2.4	V V
V _{RIHYS}	Input Hysteresis			0.3		V
R _{RIN}	Input Resistance	T _A = 25°C	3	5	7	KΩ

TIMING CHARACTERISTICS

($C_1 - C_4 = 0.1\mu\text{F}$ tested at $3.3\text{V}\pm 10\%$, $V_{\text{CC}} = 3\text{V}$ to 5.5V , $T_A = -40$ to 85°C , unless otherwise specified.
Typical values are referred to $T_A = 25^\circ\text{C}$)

Symbol	Parameter	Test Conditions	Min.	Typ.	Max.	Unit
D _R	Maximum Data Rate	R _L = 3KΩ C _L = 1000pF one trasmitter switching VHSCI=GND	250			Kbps
		R _L = 3KΩ C _L = 250pF one trasmitter switching VHSCI=V _{CC} V _{CC} = 3 to 5.55V	100			Kbps
t _{PHLR} t _{PLHR}	Propagation Delay Input to Output	R _{IN} to R _{OUT} C _L = 150pF		0.15		μs
t _{T_SKEW}	Transmitter Skew	t _{PHL} - t _{TLH} VHSCI=GND		100		ns
		t _{PHL} - t _{TLH} VHSCI=V _{CC}		60		ns
t _{R_SKEW}	Receiver Skew	t _{PHL} - t _{TLH}		50		ns
t _{OER}	Receiver Output Enable Time	Normal Operation		80		ns
t _{ODR}	Receiver Output Disable Time	Normal Operation		130		ns
S _{RT}	Transition Slew Rate	T _A = 25°C R _L = 3 to 7KΩ V _{CC} = 3.3V measured from +3V to -3V or -3V to +3V C _L = 150pF to 1000pF VHSCI=GND C _L = 150pF to 1000pF VHSCI=V _{CC} C _L = 150pF to 2500pF VHSCI=GND	6 24 4		30 150 30	V/μs V/μs V/μs

Transmitter Skew is measured at the transmitter zero cross points

APPLICATION CIRCUITS

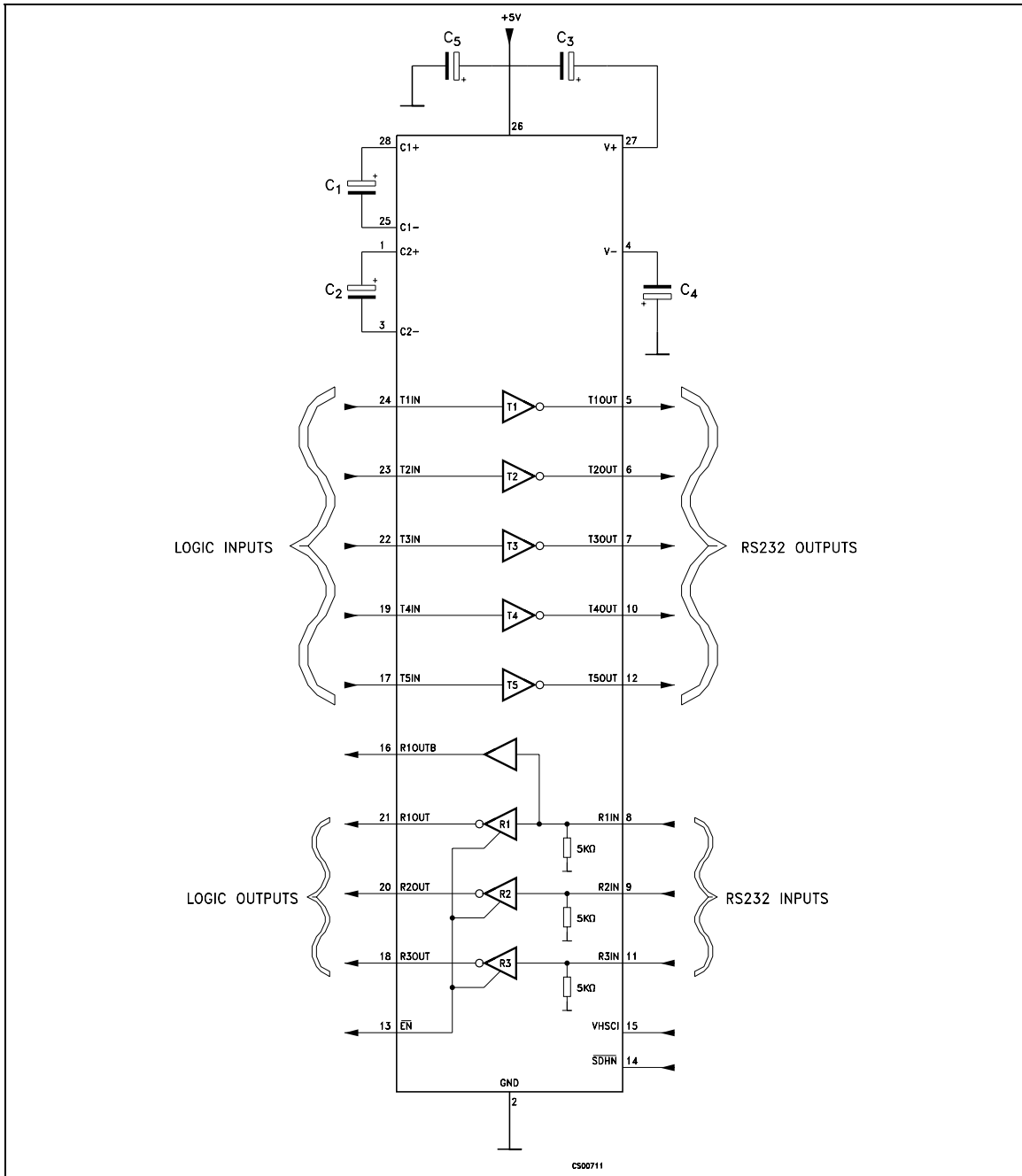

CAPACITANCE VALUE (μF)

V _{CC}	C1	C2	C3	C4	C _{bypass}
3.0 to 3.6	0.22	0.22	0.22	0.22	0.22
4.5 to 5.5	0.047	0.33	0.33	0.33	0.33
3.0 to 5.5	0.22	1.0	1.0	1.0	0.22

TYPICAL PERFORMANCE CHARACTERISTICS (unless otherwise specified $T_j = 25^\circ\text{C}$)

Figure 1 : Input Voltage Range for Transmitter

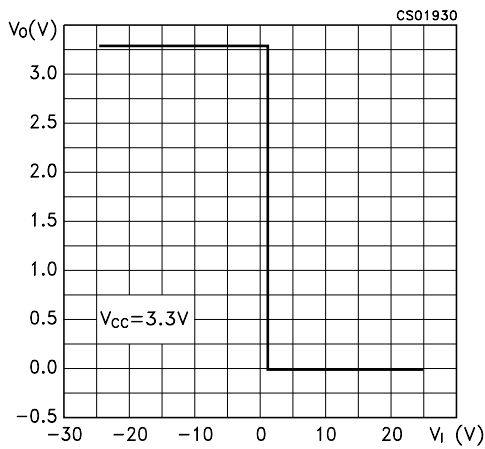

Figure 4 : Transfer Characteristics for Receiver

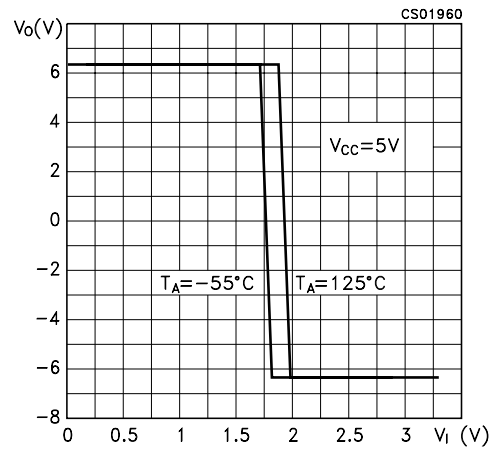

Figure 2 : Transfer Characteristics for Transmitter

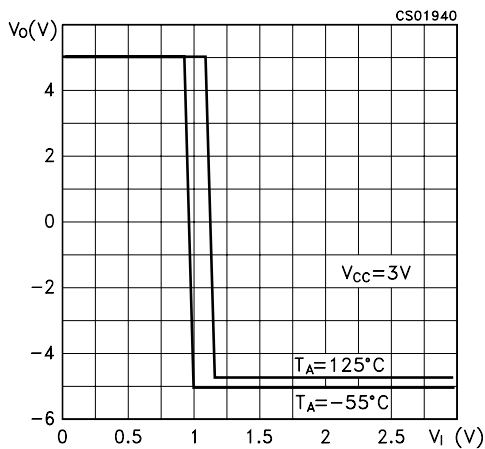

Figure 5 : Output Current vs Output High Voltage

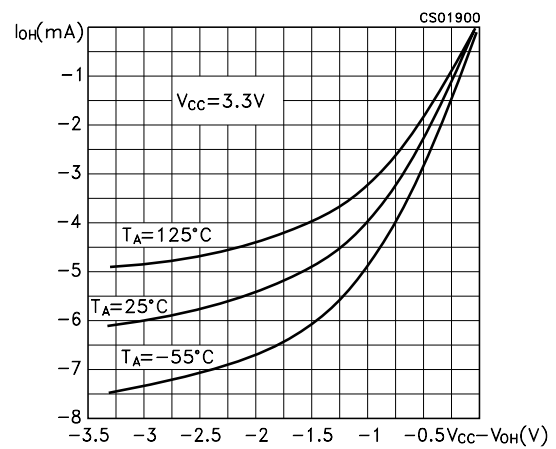

Figure 3 : Transfer Characteristics for Receiver

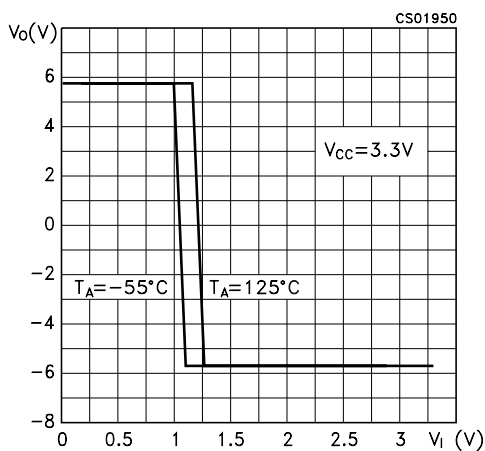

Figure 6 : Output Current vs Output Low Voltage

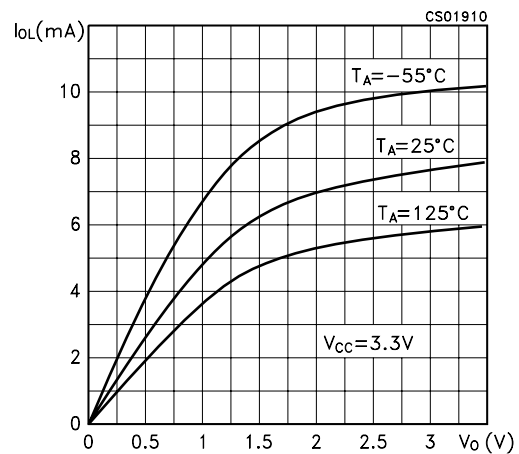
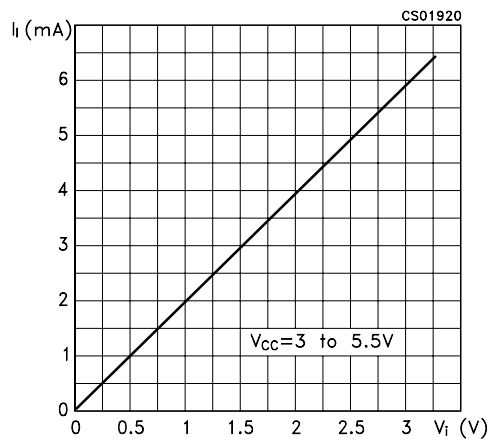
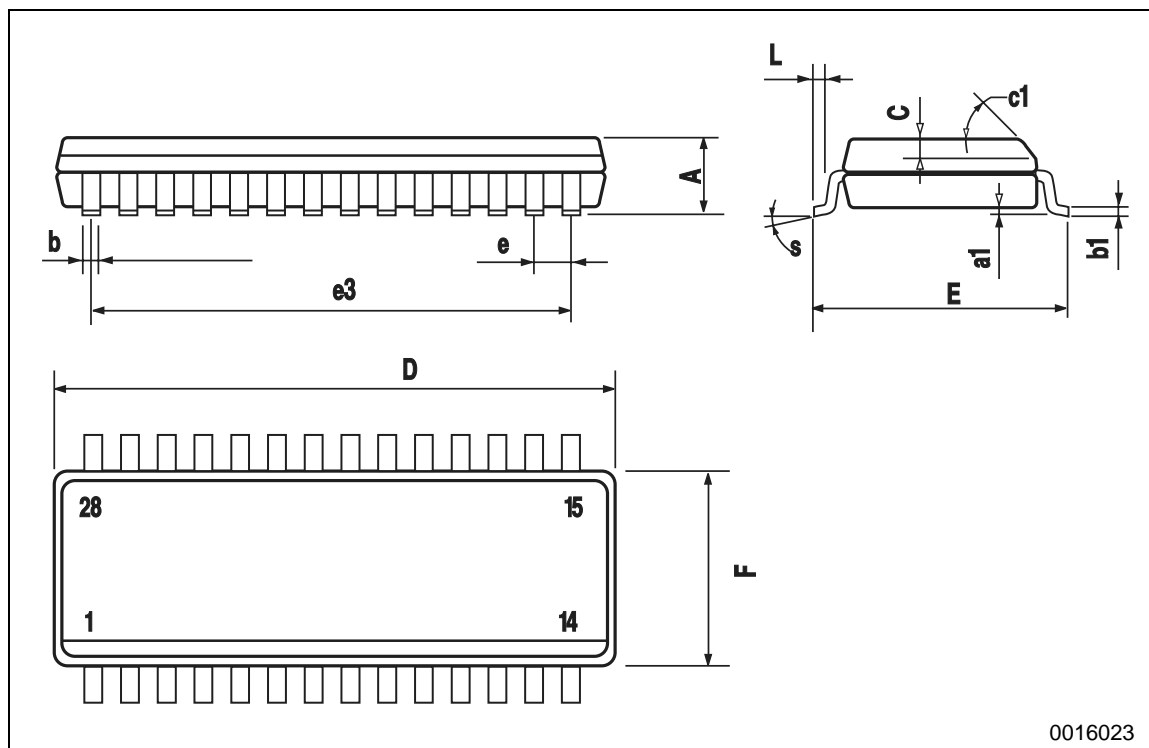

Figure 7 : Receiver Input Resistance



SO-28 MECHANICAL DATA

DIM.	mm.			inch		
	MIN.	TYP	MAX.	MIN.	TYP.	MAX.
A			2.65			0.104
a1	0.1		0.3	0.004		0.012
b	0.35		0.49	0.014		0.019
b1	0.23		0.32	0.009		0.012
C		0.5			0.020	
c1	45° (typ.)					
D	17.70		18.10	0.697		0.713
E	10.00		10.65	0.393		0.419
e		1.27			0.050	
e3		16.51			0.650	
F	7.40		7.60	0.291		0.300
L	0.50		1.27	0.020		0.050
S	8° (max.)					



SSOP28 MECHANICAL DATA

DIM.	mm.			inch		
	MIN.	TYP	MAX.	MIN.	TYP.	MAX.
A			2			0.079
A1	0.050			0.002		
A2	1.65	1.75	1.85	0.065	0.069	0.073
b	0.22		0.38	0.009		0.015
c	0.09		0.25	0.004		0.010
D	9.9	10.2	10.5	0.390	0.402	0.413
E	7.4	7.8	8.2	0.291	0.307	0.323
E1	5	5.3	5.6	0.197	0.209	0.220
e		0.65 BSC			0.0256 BSC	
K	0°		10°	0°		10°
L	0.55	0.75	0.95	0.022	0.030	0.037

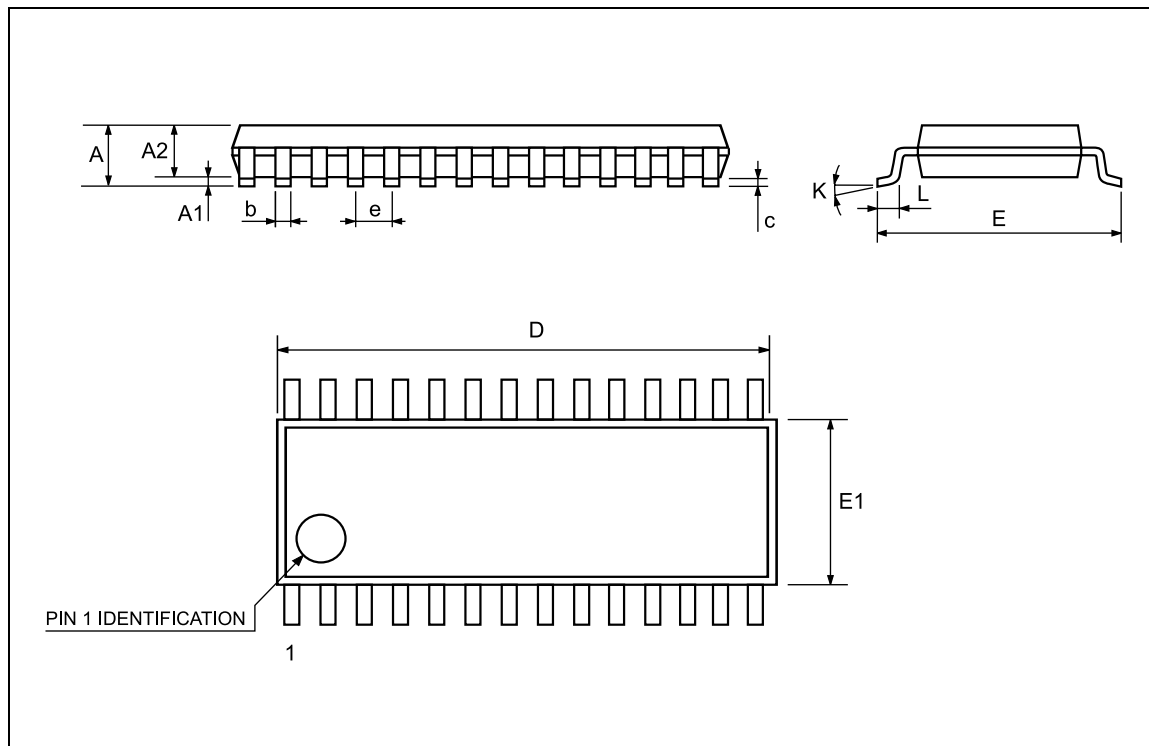

TSSOP28 MECHANICAL DATA

DIM.	mm.			inch		
	MIN.	TYP	MAX.	MIN.	TYP.	MAX.
A			1.2			0.047
A1	0.05		0.15	0.002	0.004	0.006
A2	0.8	1	1.05	0.031	0.039	0.041
b	0.19		0.30	0.007		0.012
c	0.09		0.20	0.004		0.0089
D	9.6	9.7	9.8	0.378	0.382	0.386
E	6.2	6.4	6.6	0.244	0.252	0.260
E1	4.3	4.4	4.48	0.169	0.173	0.176
e		0.65 BSC			0.0256 BSC	
K	0°		8°	0°		8°
L	0.45	0.60	0.75	0.018	0.024	0.030

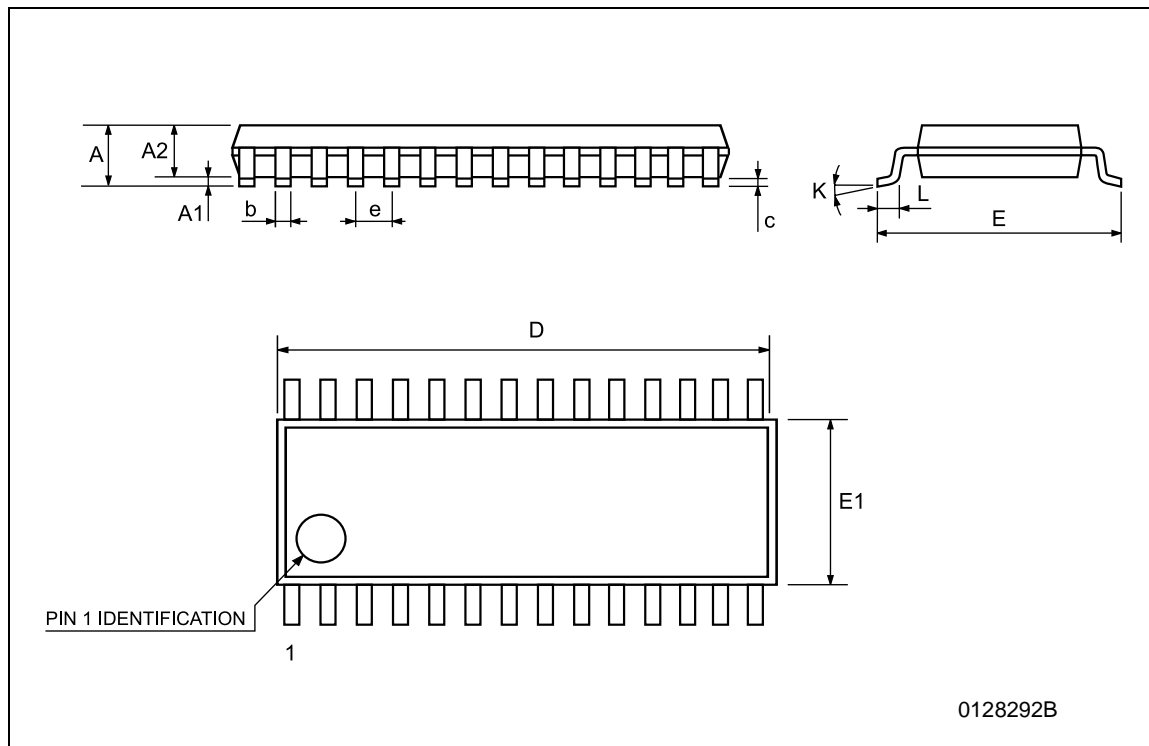

Information furnished is believed to be accurate and reliable. However, STMicroelectronics assumes no responsibility for the consequences of use of such information nor for any infringement of patents or other rights of third parties which may result from its use. No license is granted by implication or otherwise under any patent or patent rights of STMicroelectronics. Specifications mentioned in this publication are subject to change without notice. This publication supersedes and replaces all information previously supplied. STMicroelectronics products are not authorized for use as critical components in life support devices or systems without express written approval of STMicroelectronics.

© The ST logo is a registered trademark of STMicroelectronics

© 2002 STMicroelectronics - Printed in Italy - All Rights Reserved
STMicroelectronics GROUP OF COMPANIES

Australia - Brazil - Canada - China - Finland - France - Germany - Hong Kong - India - Israel - Italy - Japan - Malaysia - Malta - Morocco
Singapore - Spain - Sweden - Switzerland - United Kingdom - United States.

© <http://www.st.com>