



# MMBT2222A

## NPN SILICON TRANSISTOR

### NPN GENERAL PURPOSE AMPLIFIER

#### FEATURES

\* This device is for use as a medium power amplifier and switch requiring collector currents up to 500mA.

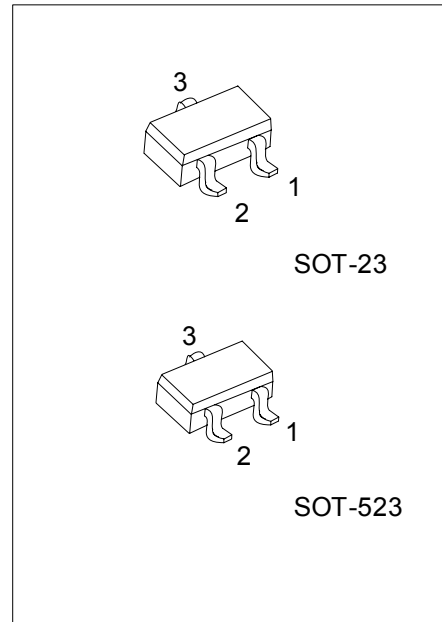

\*Pb-free plating product number:MMBT2222AL

#### ORDERING INFORMATION

Order Number		Package	Pin Assignment			Packing
Normal	Lead Free Plating		1	2	3	
MMBT2222A-AE3-R	MMBT2222AL-AE3-R	SOT-23	E	B	C	Tape Reel
MMBT2222A-AN3-R	MMBT2222AL-AN3-R	SOT-523	E	B	C	Tape Reel

<p>MMBT2222AL-AE3-R</p> <p>(1)Packing Type (2)Package Type (3)Lead Plating</p>	<p>(1) R: Tape Reel (2) AE3: SOT-23, AN3: SOT-523 (3) L: Lead Free Plating, Blank: Pb/Sn</p>
--	--

#### MARKING

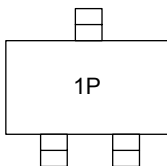

# MMBT2222A

## NPN SILICON TRANSISTOR

### ■ ABSOLUTE MAXIMUM RATINGS (Ta=25°C, unless otherwise specified.)

PARAMETER	SYMBOL	RATINGS	UNIT
Collector-Base Voltage	$V_{CBO}$	75	V
Collector-Emitter Voltage	$V_{CEO}$	40	V
Emitter-Base Voltage	$V_{EBO}$	6	V
Collector Current	$I_C$	0.6	A
Power Dissipation	SOT-23	350	mW
	SOT-523	150	mW
Junction Temperature	$T_J$	+150	
Storage Temperature	$T_{STG}$	-55 ~ +150	

Note: These are steady state limits. The factory should be consulted on applications involving pulsed or low duty cycle operations.

### ■ THERMAL DATA

PARAMETER	SYMBOL	RATINGS	UNIT
Thermal Resistance, Junction to Ambient	SOT-23	15	°C/W
	SOT-523	833	°C/W

### ■ ELECTRICAL CHARACTERISTICS (Ta=25°C, unless otherwise specified.)

PARAMETER	SYMBOL	TEST CONDITIONS	MIN	TYP	MAX	UNIT
<b>OFF CHARACTERISTICS</b>						
Collector-Base Breakdown Voltage	$BV_{CBO}$	$I_C=10\mu A, I_E=0$	75			V
Collector-Emitter Breakdown Voltage	$BV_{CEO}$	$I_C=10mA, I_B=0$	40			V
Emitter-Base Breakdown Voltage	$BV_{EBO}$	$I_E=10\mu A, I_C=0$	6			V
Collector Cutoff Current	$I_{CBO}$	$V_{CB}=60V, I_E=0$			0.01	$\mu A$
		$V_{CB}=60V, I_E=0, T_a=150^\circ C$			10	$\mu A$
Emitter Cutoff Current	$I_{EBO}$	$V_{EB}=3.0V, I_C=0$			10	nA
Base Cutoff Current	$I_{BL}$	$V_{CE}=60V, V_{EB(OFF)}=3.0V$			20	nA
Collector Cutoff Current	$I_{CEO}$	$V_{CE}=60V, V_{EB(OFF)}=3.0V$			10	nA
<b>ON CHARACTERISTICS</b>						
DC Current Gain	$h_{FE}$	$I_C=0.1mA, V_{CE}=10V$	35			
		$I_C=1.0mA, V_{CE}=10V$	50			
		$I_C=10mA, V_{CE}=10V$	75			
		$I_C=10mA, V_{CE}=10V, T_a=-55^\circ C$	35			
		$I_C=150mA, V_{CE}=10V^*$	100		300	
		$I_C=150mA, V_{CE}=1.0V^*$	50			
Collector-Emitter Saturation Voltage*	$V_{CE(SAT)}$	$I_C=150mA, I_B=15mA$			0.3	V
		$I_C=500mA, I_B=50mA$			1.0	V
Base-Emitter Saturation Voltage*	$V_{BE(SAT)}$	$I_C=150mA, I_B=15mA$	0.6		1.2	V
		$I_C=500mA, I_B=50mA$			2.0	V
<b>SMALL SIGNAL CHARACTERISTICS</b>						
Real Part of Common-Emitter High Frequency Input Impedance	$Re(h_{je})$	$I_C=20mA, V_{CB}=20V, f=300MHz$			60	$\Omega$
Transition Frequency	$f_T$	$I_C=20mA, V_{CE}=20V, f=100MHz$	300			MHz
Output Capacitance	Cobo	$V_{CB}=10V, I_E=0, f=100kHz$			8.0	pF
Input Capacitance	Cibo	$V_{EB}=0.5V, I_C=0, f=100kHz$			25	pF
Collector Base Time Constant	$rb'Cc$	$I_C=20mA, V_{CB}=20V, f=31.8MHz$			150	pS
Noise Figure	NF	$I_C=100\mu A, V_{CE}=10V, R_s=1.0k\Omega, f=1.0kHz$			4.0	dB

■ ELECTRICAL CHARACTERISTICS(Cont.)

SWITCHING CHARACTERISTICS						
Delay Time	$t_D$	$V_{CC}=30V, V_{BE(OFF)}=0.5V,$			10	ns
Rise Time	$t_R$	$I_C=150mA, I_{B1}=15mA$			25	ns
Storage Time	$t_S$	$V_{CC}=30V, I_C=150mA$			225	ns
Fall Time	$t_F$	$I_{B1}= I_{B2}=15mA$			60	ns

\*Pulse test: Pulse Width  $\leq 300\mu s$ , Duty Cycle  $\leq 2.0\%$

### ■ TEST CIRCUITS

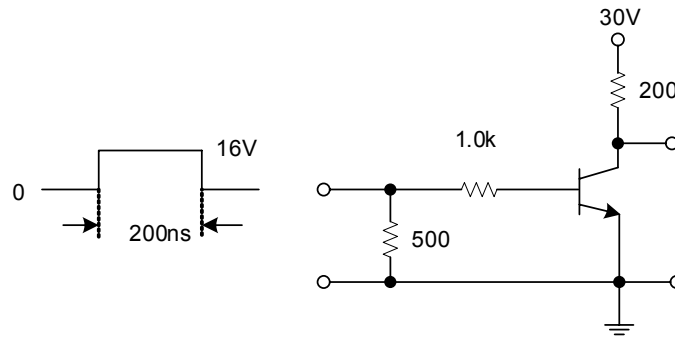

FIG.1 Saturated Turn-On Switching Time

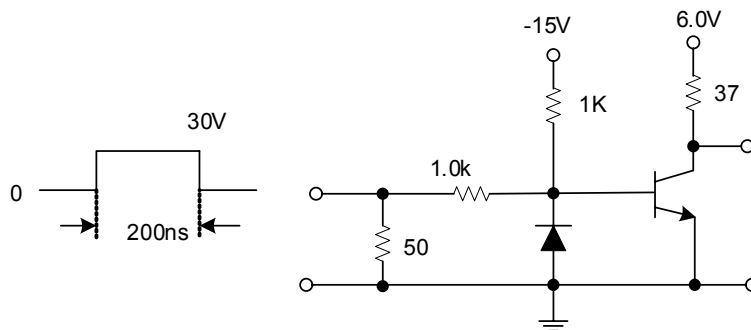
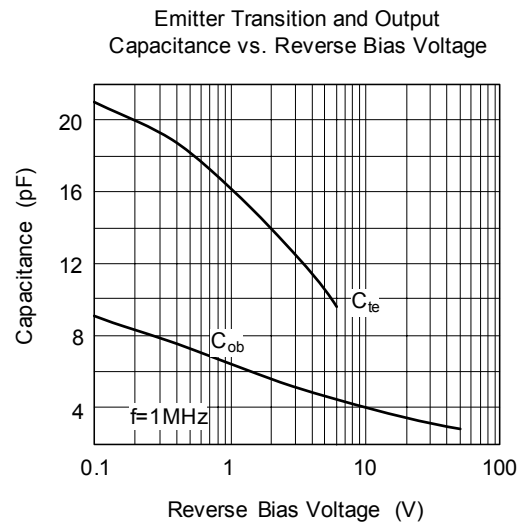
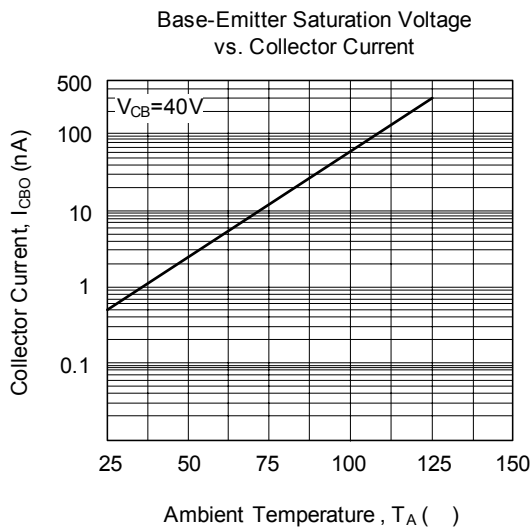
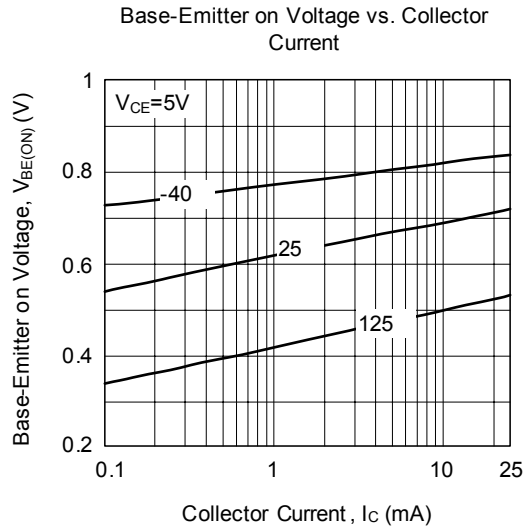
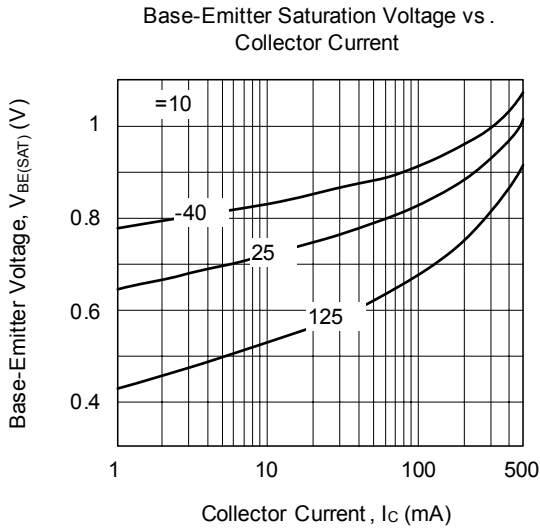
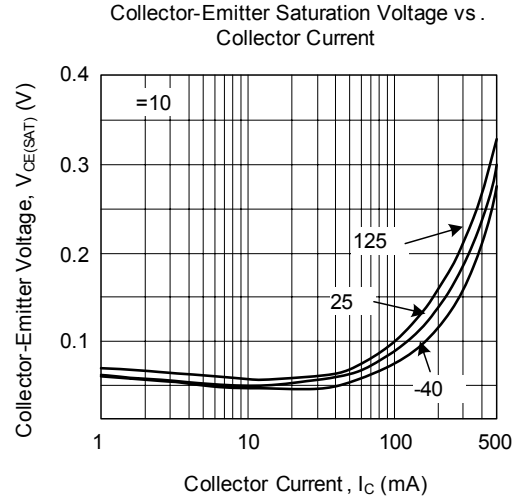
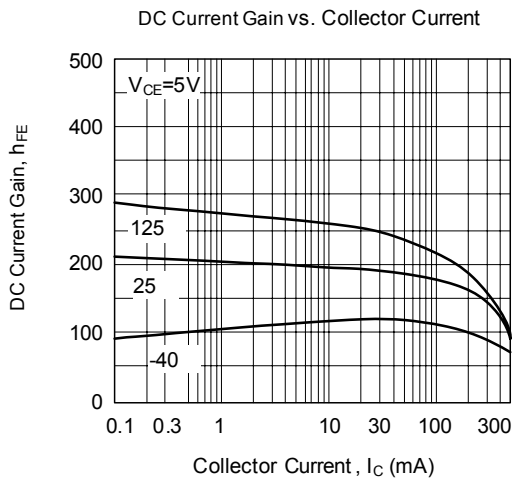
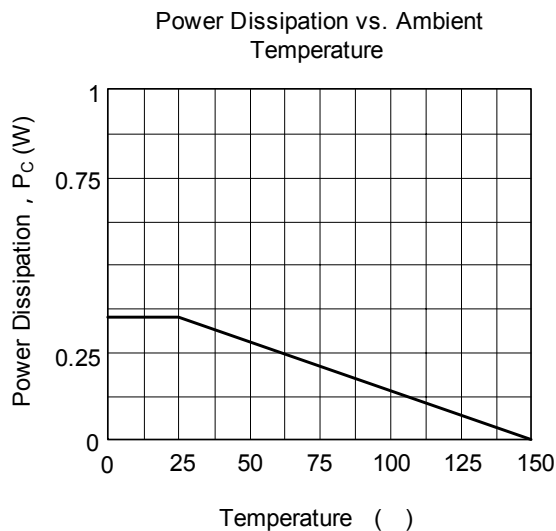
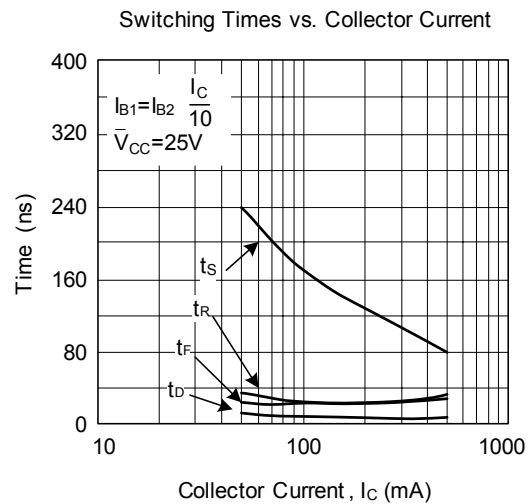
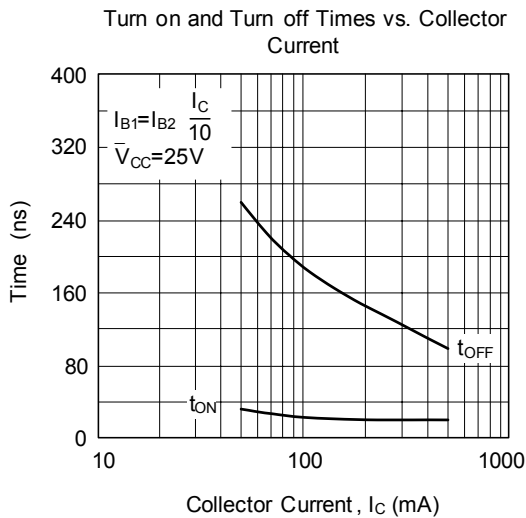

FIG.2 Saturated Turn-Off Switching Time

## TYPICAL CHARACTERISTICS



■ TYPICAL CHARACTERISTICS(Cont.)



UTC assumes no responsibility for equipment failures that result from using products at values that exceed, even momentarily, rated values (such as maximum ratings, operating condition ranges, or other parameters) listed in products specifications of any and all UTC products described or contained herein. UTC products are not designed for use in life support appliances, devices or systems where malfunction of these products can be reasonably expected to result in personal injury. Reproduction in whole or in part is prohibited without the prior written consent of the copyright owner. The information presented in this document does not form part of any quotation or contract, is believed to be accurate and reliable and may be changed without notice.