

Metal Glaze™ General Purpose Surface Mount Power Resistor

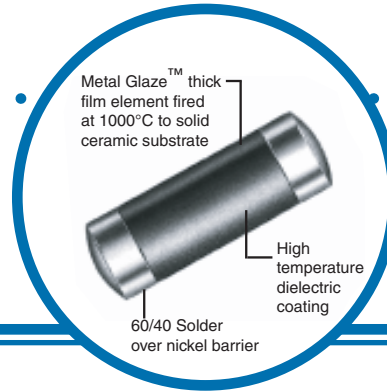

MM Series

- Up to 2 watts
- Up to 1000 volts
- 0.1 ohm to 2.2 megohm range
- 150°C maximum operating temperature



Electrical Data

Size Code	Industry Footprint	IRC Type	Maximum Power Rating	Working Voltage ²	Resistance Range (ohms)	Tolerance (+%) ³	TCR (ppm/°C) ³	Product Category
B	1206	MMA0204	1/2	400	0.1 to 0.99	1, 2, 5	100	Low Range
					1.0 to 1.0M	1, 2, 5	50, 100	Standard
					20 to 348K	0.25, 0.5	50, 100	Tight Tolerance
F	2512	MMB0207	1	700	0.1 to 0.99	1, 2, 5	100	Low Range
					1.0 to 2.21M	1, 2, 5	50, 100	Standard
					20 to 348K	0.25, 0.5	50, 100	Tight Tolerance
H	3610	MMC0310	2	1000	0.1 to 0.99	1, 2, 5	100	Low Range
					1.0 to 2.21M	1, 2, 5	50, 100	Standard

¹Not to exceed $\sqrt{P \times R}$ ²Consult factory for tighter TCR, tolerance, or resistance values.

Environmental Data

Characteristics	Maximum Change	Test Method
Temperature Coefficient	As specified	MIL-R-55342E Par 4.7.9 (-55°C +125°C)
Thermal Shock	±0.5% +0.01Ω	MIL-R-55342E Par 4.7.3 (-65°C +150°C, 5 cycles)
Low Temperature Operation	±0.25% +0.01Ω	MIL-R-55342E Par 4.7.4 (-65°C @ working voltage)
Short Time Overload	±0.5% +0.01Ω ±1% for R>100KΩ	MIL-R-55342E Par 4.7.5 2.5 x $\sqrt{P \times R}$ for 5 seconds
High Temperature Exposure	±0.5% +0.01Ω	MIL-R-55342E Par 4.7.6 (+150°C for 100 hours)
Resistance to Bonding Exposure	±0.25% +0.01Ω	MIL-R-55342E Par 4.7.7 (Reflow soldered to board at 260°C for 10 seconds)
Solderability	95% minimum coverage	MIL-STD-202, Method 208 (245°C for 5 seconds)
Moisture Resistance	±0.5% +0.01Ω	MIL-R-55342E Par 4.7.8 (10 cycles, total 240 hours)
Life Test	±0.5% +0.01Ω	MIL-R-55342E Par 4.7.10 (2000 hours @ 70°C intermittent)
Terminal Adhesion Strength	±1% +0.01Ω no mechanical damage	1200 gram push from underside of mounted chip for 60 seconds
Resistance to Board Bending	±0.5% +0.01Ω no mechanical damage	Chip mounted in center of 90mm long board, deflected 5mm so as to exert pull on chip contacts for 10 seconds

General Note

IRC reserves the right to make changes in product specification without notice or liability. All information is subject to IRC's own data and is considered accurate at time of going to print.

Wire and Film Technologies Division • 4222 South Staples Street • Corpus Christi Texas 78411 USA
Telephone: 361 992 7900 • Facsimile: 361 992 3377 • Website: www.ircitt.com



MM Series Issue March 2009 Sheet 1 of 3

Metal Glaze™ General Purpose Surface Mount Power Resistor



Physical Data

Size Code	Industry Footprint	Actual Size	Dimensions (Inches and (mm))		
			L	W	C*
			B	1206	
F	2512		0.251 ± 0.010 (6.38 ± 0.25)	0.079 ± 0.006 (2.01 ± 0.15)	0.040 ± 0.010 (1.02 ± 0.25)
H	3610		0.367 ± 0.010 (9.32 ± 0.25)	0.105 ± 0.006 (2.67 ± 0.15)	0.050 ± 0.010 (1.27 ± 0.25)

*C dimension is average termination width.

Recommended Solder Pad Dimensions (Reflow):

Size Code	Industry Footprint	Dimensions (Inches and mm)					
		A	B	C	D	E	F
B	1206	0.076 (1.93)	0.093 (2.36)	0.058 (1.47)	0.098 (2.49)	0.032 (0.81)	0.211 (5.36)
F	2512	0.121 (3.07)	0.126 (3.20)	0.127 (3.23)	0.183 (4.65)	0.040 (1.02)	0.369 (9.37)
H	3610	0.170 (4.32)	0.160 (4.06)	0.213 (5.41)	0.273 (6.93)	0.044 (1.12)	0.553 (14.05)

Metal Glaze™ General Purpose Surface Mount Power Resistor



Standard Reel Packaging per EIA-481:

Size Code	Industry Footprint	Reel Diameter*	Quantity Per Reel	Carrier Tape Width	Component Pitch
B	1206	7"	2,500 max.	8mm	4mm
		13"	10,000 max.		
F	2512	7"	1,500 max.	12mm	4mm
		13"	5,000 max.		
H	3610	13"	1,500 max.	24mm	4mm

*The 13" reel is considered standard and will be supplied unless otherwise specified.

Power Derating Curve

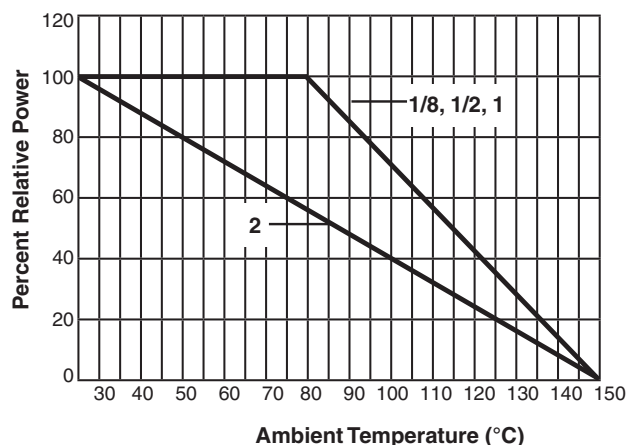

Repetitive Surge Curve

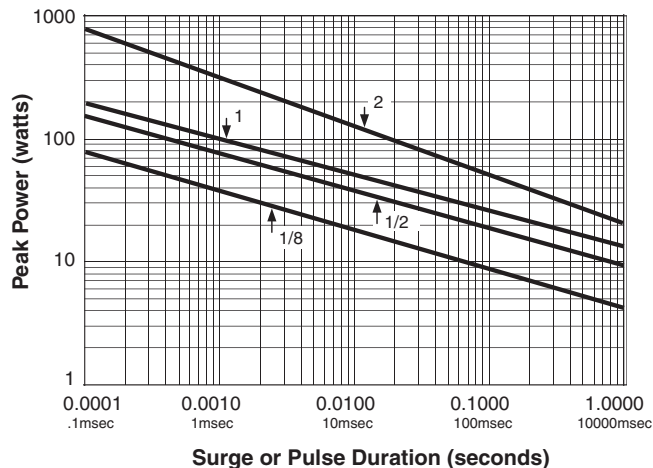

Note: Use for repetitive pulses where the average power dissipation is not to exceed the component rating at 70°C. Surge handling capacity for low-repetitive surges may be significantly greater than shown above. Contact factory for recommendations.

Ordering Data

Sample Part No.	MMA0204	50	2203	F	13
IRC Type (MMA0204, MMB0207, MMC0310)					
Temperature Coefficient 50 = ±50 ppm/°C; 100 = ±100 ppm/°C					
Resistance Value (100 ohms and greater - First 3 significant figures plus 4th digit multiplier) Example: 100 ohms = 1000, 1000 ohms = 1001, 150,000 ohms = 1503 (Less than 100 ohms - 'R' is used to designate decimal) Example: 51 ohms = 51R0, 1 ohm = 1R00, 0.25 ohm = R250					
Tolerance (D = 0.5%, F = 1.0%)					
Packaging Details (BLK = Bulk, 7 = 7" Reel, 13 = 13" Reel)					

Note:

RoHS compliance is noted by inserting "LF" into the part number immediately following the tolerance designator. RoHS compliant metallization is 96.5% Sn / 3% Ag / 0.5% Cu. RoHS-compliant product is NOT backwards compatible to Sn/Pb soldering environments.