

100 Hz to 100 kHz
Low Noise Fixed Frequency

**2 – Pole Pair
Band - Pass Filters**

Description:

The D100B Series are low noise and distortion 2-pole-pair, fixed center frequency (f_o) band-pass filters. These filters feature near theoretical low noise and distortion performance, by providing up to -120 dB noise floors (20-Bit). D100B's take advantage of FDI's design expertise utilizing high performance amplifiers and surface-mount technology to provide design engineers with precision signal conditioning solutions in a compact package. These fully self-contained units require no external components or adjustments. Each D100B comes factory tuned to a user specified corner frequency between 100 Hz to 100 kHz. Available Q's for D100B models are 1, 2 or 5 and operate with low harmonic distortion over an input voltage range to ± 10 V.



Features/Benefits:

- Small 32-pin DIP (1.8"L x 0.8"W) footprint minimizes board space requirements.
- Plug-in ready-to-use, reducing engineering design and manufacturing cycle time.
- Factory tuned, no external clocks or adjustments needed.
- Broad range of center frequencies to meet a wide range of applications.

Available Band-Pass Models:
D100BP2 2-Pole Pair

Page
2

General Specifications

Pin-out/package data & order information 3

Applications

- Transducer output filtering.
- Production test instrumentation
- Medical electronics equipment and research
- Noise and harmonic analysis
- Frequency spectrum analysis



100 Hz to 100 kHz
Low Noise Fixed Frequency

2 – Pole Pair
Band - Pass Filters

Model	D100BP2
Product Specifications	
Size	1.8" x 0.8" x 0.3"
Range f_o	100 Hz to 100 kHz
Available "Q's" ¹	1, 2 or 5
"Q" Accuracy	±10 %
Theoretical Transfer Characteristics	Appendix A Pages 39 & 40
Pass-Band Gain (non-inverting)	0 ± 0.2 dB typ. 0 ± 0.4 dB max.
Attenuation Rate	12 dB/octave
Center Frequency Stability	f _o ± 1% max. ± 0.01%/°C
(THD) Total Harmonic Distortion @ 10 Vp-p F _o ≤ 100 Hz F _o ≤ 20 kHz F _o ≤ 100 kHz	<-120 dB max. <-117 dB max. <-100 dB max.
Narrow Band Noise 100 kHz BW @ 20V p-p F _o ≤ 100 Hz F _o ≤ 20 kHz F _o ≤ 100 kHz	(μV rms) 7.0 typ., 12 max. 22 typ., 40 max. 70 typ., 100 max.
Filter Mounting ² Assembly	FMA-01S

1. Q – Quality Factor for band-pass and band-reject filters. $Q = f_o / (f_H - f_L)$, $f_o = \sqrt{f_H f_L}$
2. Use I/O jumpers to bypass input and output buffers, for low noise operation. With FMA, D100B distortion specs at 50k to 100kHz may degrade slightly.

**Specifications
(25°C and $V_s \pm 15$ Vdc)**
Analog Input Characteristics¹

Impedance	1.0 k Ω min.
Voltage Range	$\pm 10 V_{peak}$
Max. Safe Voltage	$\pm V_s$

Analog Output Characteristics

Load Impedance	1.0 k Ω min.
Linear Operating Range for THD	$\pm 5V$
Operating Range for Low Noise	$\pm 10V$
Current ² @ (V_s @ $\pm 15V$)	10 mA max.
Offset Voltage ³	2 mV typ. 20 mV max.
Offset Temp. Coefficient	50 $\mu V/^\circ C$

Power Supply ($\pm V_s$)

Rate Voltage	$\pm 15V$
Operating Range	$\pm 5V$ min. $\pm 18V$ max.
Quiescent Current	40 mA max

Temperature Range

Operating	0°C to +70°C
Storage	-25°C to +85°C

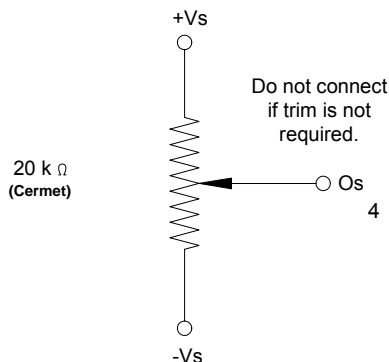
DC Offset Adjustment

Notes:

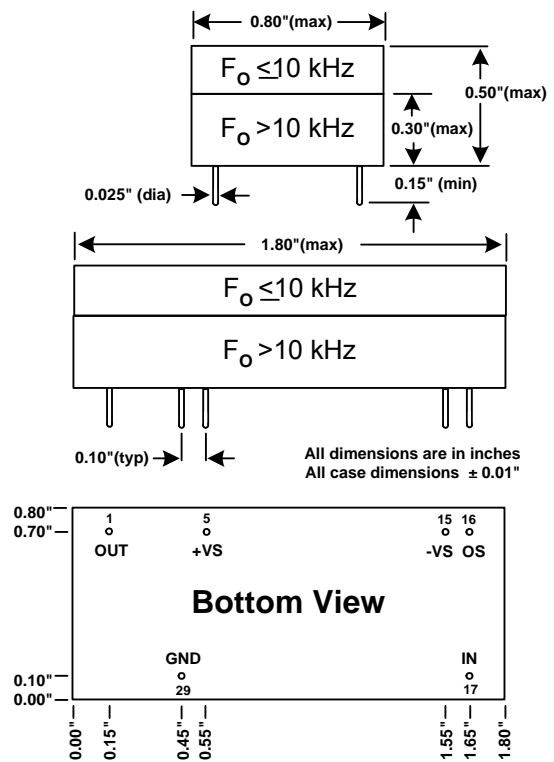
1. Input and output signal voltage referenced to supply common.
2. Output is short circuit protected to common. DO NOT CONNECT TO $\pm V_s$.
3. Adjustable to zero.
4. Units operate with or without offset pin connected.
5. How to specify Center Frequency F_0 . Center frequency is specified by attaching a three-digit frequency designator to the basic model number. Center frequencies can range from 100 Hz to 100 kHz.

**Pin-Out and Package Data
Ordering Information**

ORDERING INFORMATION
D100BP2/5-10.0 kHz

“Q” 1, 2, 5	F_0 Center Frequency ⁵ e.g., 849 Hz 2.50 kHz 33.3 kHz
----------------	---

We hope the information given here will be helpful. The information is based on data and our best knowledge, and we consider the information to be true and accurate. Please read all statements, recommendations or suggestions herein in conjunction with our conditions of sale, which apply, to all goods supplied by us. We assume no responsibility for the use of these statements, recommendations or suggestions, nor do we intend them as a recommendation for any use, which would infringe any patent or copyright.

PR-D100BP2



Amplitude Response Curves

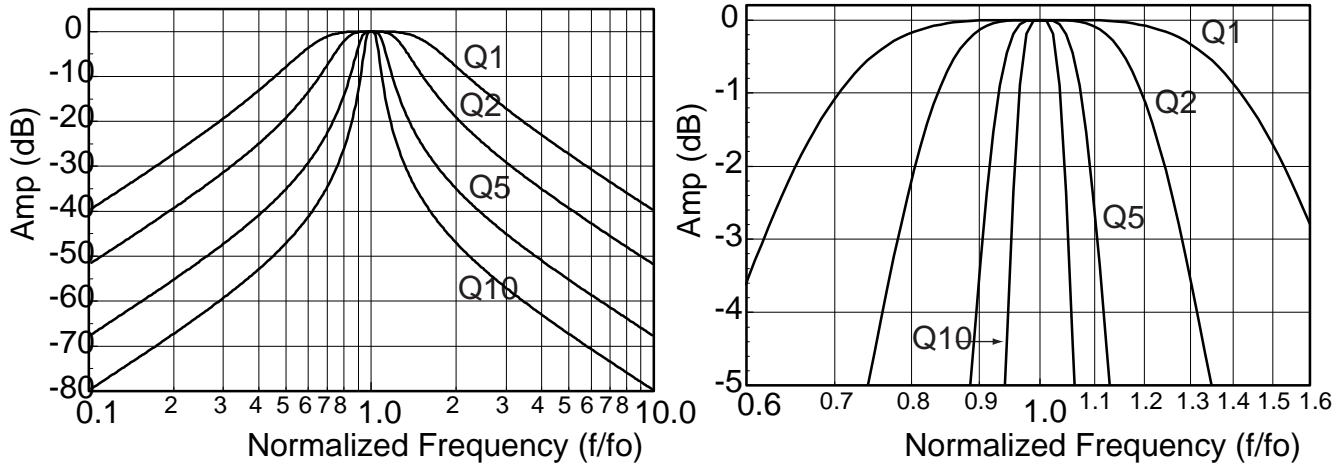

Amp (dB)	Q = 1		Q = 2		Q = 5		Q = 10	
	$f_L < f_o < f_H$		$f_L < f_o < f_H$		$f_L < f_o < f_H$		$f_L < f_o < f_H$	
	f/f_o	f/f_o	f/f_o	f/f_o	f/f_o	f/f_o	f/f_o	f/f_o
-0.10	0.824	1.214	0.907	1.102	0.962	1.040	0.981	1.020
-0.25	0.783	1.277	0.884	1.131	0.952	1.051	0.976	1.025
-0.50	0.747	1.338	0.863	1.159	0.943	1.061	0.971	1.030
-1.00	0.705	1.418	0.837	1.194	0.931	1.074	0.965	1.036
-1.50	0.677	1.478	0.820	1.220	0.923	1.083	0.961	1.041
-2.00	0.654	1.529	0.805	1.242	0.916	1.091	0.957	1.045
-2.50	0.635	1.574	0.792	1.262	0.910	1.098	0.954	1.048
-3.00	0.618	1.617	0.781	1.280	0.905	1.105	0.951	1.051
-5.00	0.563	1.776	0.742	1.348	0.886	1.129	0.941	1.062
-10.00	0.457	2.189	0.657	1.523	0.842	1.188	0.917	1.090
-15.00	0.368	2.720	0.572	1.748	0.792	1.263	0.889	1.125
-20.00	0.290	3.445	0.485	2.062	0.733	1.364	0.855	1.170
-25.00	0.225	4.439	0.399	2.506	0.664	1.507	0.811	1.233
-30.00	0.173	5.795	0.319	3.130	0.585	1.709	0.758	1.320
-35.00	0.131	7.630	0.250	3.999	0.500	2.000	0.693	1.443
-40.00	0.099	10.09	0.193	5.192	0.414	2.414	0.618	1.618
-45.00	0.075	13.41	0.147	6.814	0.333	3.001	0.535	1.869
-50.00	0.056	17.83	0.111	9.002	0.262	3.819	0.449	2.228
-55.00	0.042	23.75	0.084	11.94	0.202	4.945	0.365	2.737
-60.00	0.032	31.65	0.063	15.87	0.154	6.479	0.290	3.453
-65.00	0.024	42.19	0.047	21.13	0.117	8.552	0.225	4.443
-70.00	0.018	56.25	0.036	28.15	0.088	11.33	0.172	5.798
-75.00	0.013	75.00	0.027	37.52	0.066	15.06	0.131	7.632
-80.00	0.010	100.0	0.020	50.01	0.050	20.05	0.099	10.10



Appendix A

Phase Response Curves

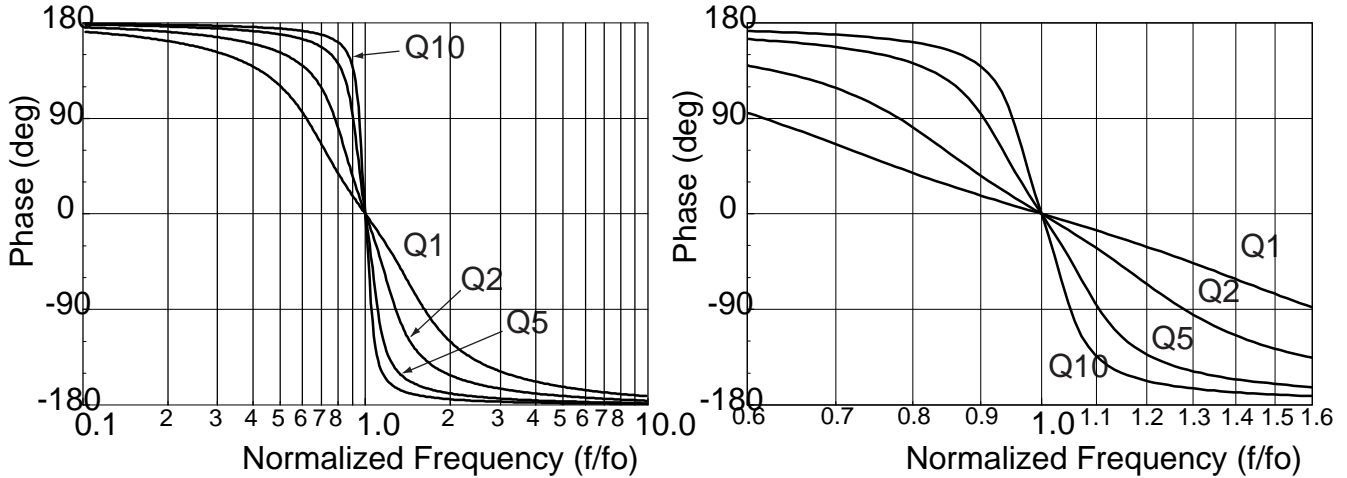

Normalized Theoretical Phase Data

Phase Mag (deg)	Q = 1		Q = 2		Q = 5		Q = 10	
	(+)	(-)	(+)	(-)	(+)	(-)	(+)	(-)
	f/f ₀	f/f ₀	f/f ₀	f/f ₀	f/f ₀	f/f ₀	f/f ₀	f/f ₀
1.0	0.994	1.006	0.997	1.003	0.999	1.001	0.999	1.001
2.5	0.985	1.016	0.992	1.008	0.997	1.003	0.998	1.002
5.0	0.970	1.031	0.985	1.016	0.994	1.006	0.997	1.003
10.0	0.940	1.063	0.970	1.031	0.988	1.012	0.994	1.006
15.0	0.913	1.096	0.955	1.047	0.982	1.018	0.991	1.009
20.0	0.886	1.128	0.941	1.062	0.976	1.025	0.988	1.012
25.0	0.861	1.161	0.928	1.078	0.970	1.030	0.985	1.015
30.0	0.838	1.194	0.915	1.093	0.965	1.036	0.982	1.018
35.0	0.815	1.227	0.902	1.108	0.960	1.042	0.980	1.021
40.0	0.794	1.259	0.891	1.123	0.955	1.048	0.977	1.024
45.0	0.774	1.292	0.879	1.138	0.950	1.053	0.974	1.026
50.0	0.755	1.324	0.868	1.152	0.945	1.059	0.972	1.029
60.0	0.719	1.391	0.846	1.182	0.935	1.069	0.967	1.034
70.0	0.685	1.460	0.825	1.212	0.925	1.081	0.962	1.040
80.0	0.652	1.535	0.803	1.245	0.916	1.092	0.957	1.045
90.0	0.618	1.618	0.781	1.281	0.905	1.105	0.951	1.051
105.0	0.564	1.772	0.743	1.346	0.887	1.128	0.941	1.062
120.0	0.502	1.991	0.695	1.439	0.862	1.160	0.928	1.077
135.0	0.424	2.356	0.628	1.594	0.825	1.212	0.908	1.101
150.0	0.320	3.126	0.520	1.923	0.758	1.319	0.869	1.150
165.0	0.177	5.639	0.327	3.058	0.593	1.686	0.764	1.310
180.0	0	inf	0	inf	0	inf	0	inf