

Rectifier diode fast, high-voltage

BY559-1500

FEATURES

- Low forward volt drop
- Low forward recovery voltage
- Fast switching
- Soft recovery characteristic
- High thermal cycling performance
- Low thermal resistance

SYMBOL

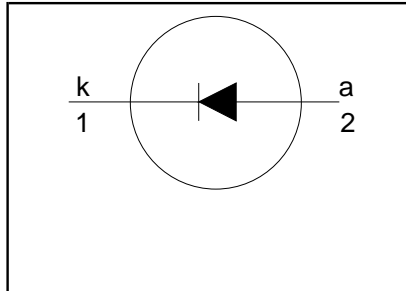

QUICK REFERENCE DATA

$$V_R = 1500 \text{ V}$$

$$V_F \leq 1.2 \text{ V}$$

$$V_{fr} \leq 14 \text{ V}$$

$$t_{fr} \leq 250 \text{ ns}$$

$$I_{F(AV)} = 10 \text{ A}$$

$$I_{FSM} \leq 100 \text{ A}$$

GENERAL DESCRIPTION

Glass-passivated double diffused rectifier diode featuring fast forward recovery and low forward recovery voltage. The device is intended for use in multi-sync monitor horizontal deflection circuits with maximum scan rates from 82 kHz to 120 kHz.

The BY559 series is supplied in the conventional leaded SOD59 (TO220AC) package.

PINNING

PIN	DESCRIPTION
1	cathode
2	anode
tab	cathode

SOD59 (TO220AC)

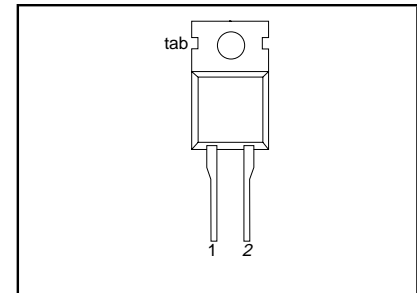

LIMITING VALUES

Limiting values in accordance with the Absolute Maximum System (IEC 134).

SYMBOL	PARAMETER	CONDITIONS	MIN.	MAX.	UNIT
V_{RRM}	Peak repetitive reverse voltage		-	1500	V
V_{RWM}	Crest working reverse voltage		-	1300	V
I_{FWM}	Peak working forward current	$f = 120 \text{ kHz};$	-	10	A
I_{FRM}	Peak repetitive forward current	$t = 100 \mu\text{s}$	-	150	A
I_{FSM}	Peak non-repetitive forward current	$t = 10 \text{ ms}$ $t = 8.3 \text{ ms}$ sinusoidal; $T_j = 150 \text{ }^\circ\text{C}$ prior to surge; with reapplied $V_{RWM(max)}$	-	180	A
T_{stg}	Storage temperature		-40	150	$^\circ\text{C}$
T_j	Operating junction temperature		-	150	$^\circ\text{C}$

THERMAL RESISTANCES

SYMBOL	PARAMETER	CONDITIONS	MIN.	TYP.	MAX.	UNIT
$R_{th\ j-mb}$	Thermal resistance junction to mounting base		-	-	1.0	K/W
$R_{th\ j-a}$	Thermal resistance junction to ambient	in free air	-	60	-	K/W

**Rectifier diode
fast, high-voltage**

BY559-1500

STATIC CHARACTERISTICS $T_j = 25\text{ °C}$ unless otherwise stated

SYMBOL	PARAMETER	CONDITIONS	MIN.	TYP.	MAX.	UNIT
V_F	Forward voltage	$I_F = 10\text{ A}$	-	1.0	1.25	V
		$I_F = 10\text{ A}; T_j = 125\text{ °C}$	-	0.79	0.9	V
I_R	Reverse current	$V_R = V_{RWMmax}$	-	-	0.5	mA
		$V_R = V_{RWMmax}; T_j = 125\text{ °C}$	-	-	2.0	mA

DYNAMIC CHARACTERISTICS $T_j = 25\text{ °C}$ unless otherwise stated

SYMBOL	PARAMETER	CONDITIONS	MIN.	TYP.	MAX.	UNIT
V_{fr}	Forward recovery voltage	$I_F = 10\text{ A}; di_F/dt = 50\text{ A}/\mu\text{s}$	-	7	11	V
t_{fr}	Forward recovery time	$I_F = 10\text{ A}; di_F/dt = 50\text{ A}/\mu\text{s}; V_F = 5\text{ V}$	-	250	350	ns
		$I_F = 10\text{ A}; di_F/dt = 50\text{ A}/\mu\text{s}; V_F = 2\text{ V}$	-	450	600	ns
t_{rr}	Reverse recovery time	$I_F = 1\text{ A}; -di_F/dt = 50\text{ A}/\mu\text{s}; V_R \geq 30\text{ V}$	-	0.75	1.0	μs
Q_s	Reverse recovery charge	$I_F = 2\text{ A}; -di_F/dt = 20\text{ A}/\mu\text{s}; V_R \geq 30\text{ V}$	-	4.0	5.0	μC

Rectifier diode
fast, high-voltage

BY559-1500

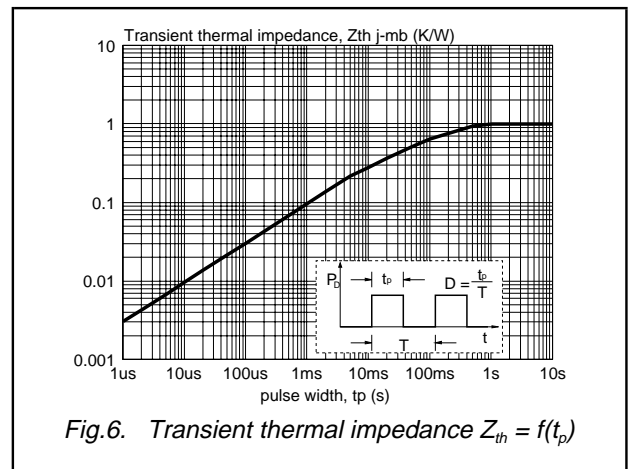
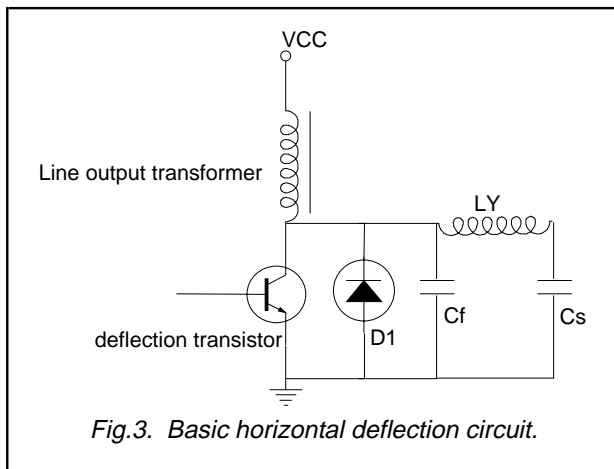
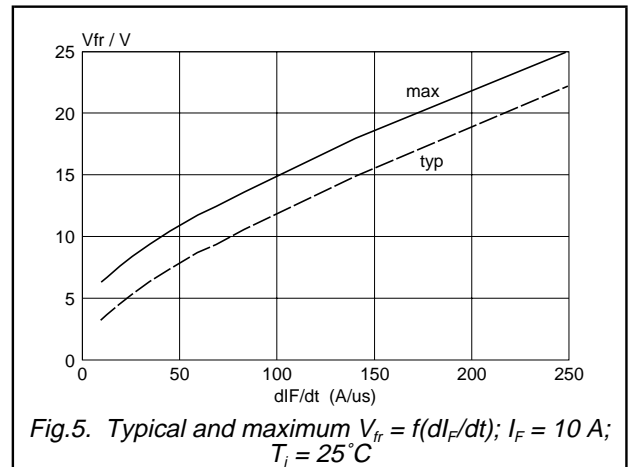
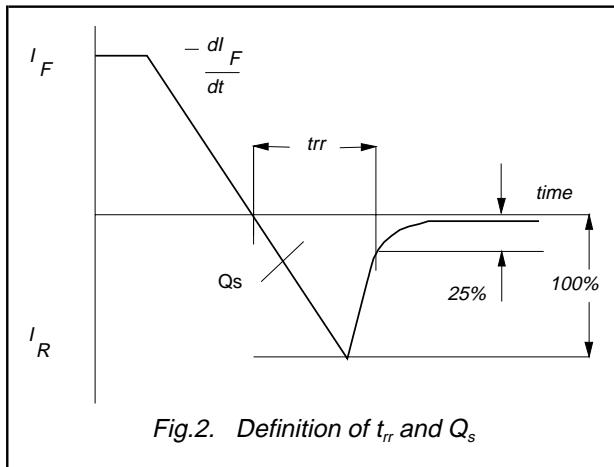
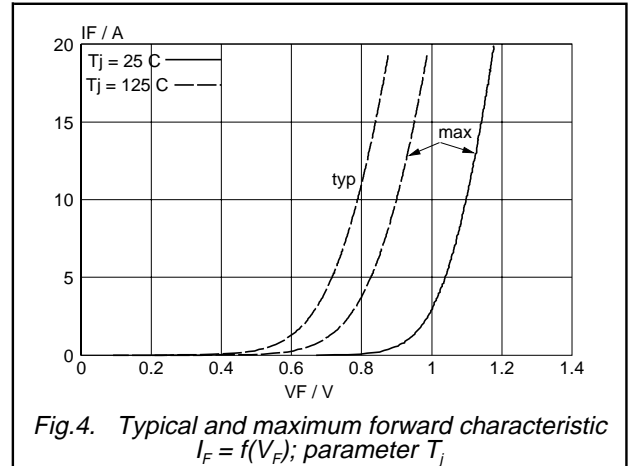
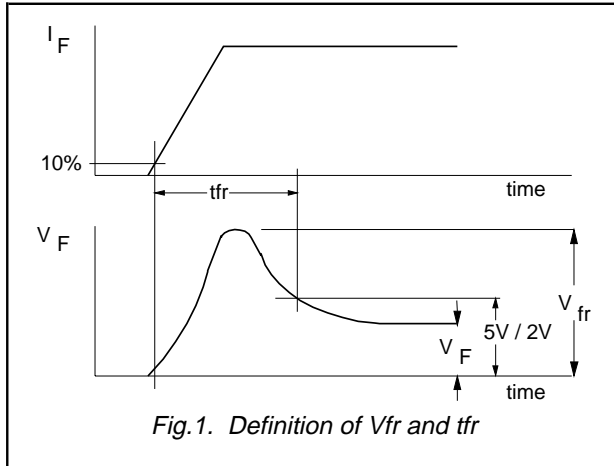

Rectifier diode
fast, high-voltage

BY559-1500

MECHANICAL DATA

Dimensions in mm

Net Mass: 2 g

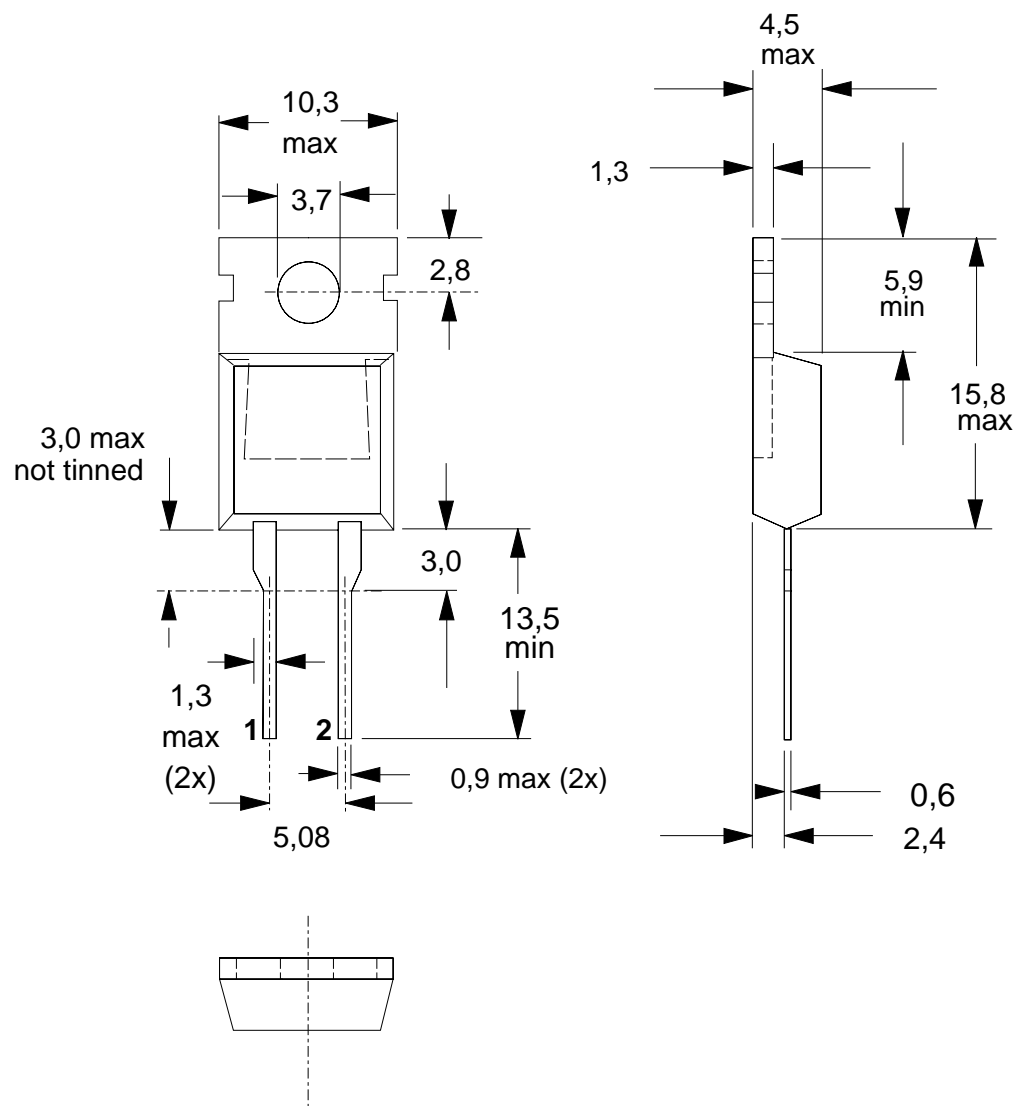

Fig.7. SOD59 (TO220AC). pin 1 connected to mounting base.

Notes

1. Refer to mounting instructions for TO220 envelopes.
2. Epoxy meets UL94 V0 at 1/8".