



VOLTAGE REGULATOR

MB3752

February 1988
Edition 1.0

VOLTAGE REGULATOR

The Fujitsu MB3752 is a monolithic voltage regulator IC. It contains a temperature compensated reference voltage circuit, a surge protected error amplifier and high current protected circuit.

High current regulator, negative power supply regulator, floating regulator and switching regulator are made up by selection of external components.

Constant current limiting or foldback current limiting is selected by selection of external components.

It is suitable both industrial and consumer voltage regulator system.

The high performance makes a lot of application and enables operation with various functions.

- High Load Regulation: 0.03 % ($1 \text{ mA} \leq I_L \leq 50 \text{ mA}$)
- Wide Input Voltage Range: 40 V max.
- Wide Output Voltage Range: 2 V to 37 V
- Compatible with Fairchild $\mu\text{A}723$
- Packages
 - 14-pin plastic DIP package (Suffix: -P)
 - 14-pin ceramic DIP package (Suffix: -Z)
 - 14-pin plastic Flat package (Suffix: -PF)

ABSOLUTE MAXIMUM RATINGS (see NOTE) ($T_A = 25^\circ\text{C}$)

Rating	Symbol	Value			Unit
		Ceramic	Plastic	Flat	
Storage Temperature	TSTG	-65 - +150	-55 - +125	-55 - +125	$^\circ\text{C}$
Operating Temperature	T_A	-55 - +125	-20 - +75	-20 - +75	$^\circ\text{C}$
Power Dissipation	PD	1000	800	620 *	mW
Output Current	I_L	150	150	150	mA
Zener Current	I_Z	25	25	25	mA
Current from VREF	I_R	15	15	15	mA
Input Voltage	V_{IN}	40	40	40	V

NOTE: FLAT package is mounted on the epoxy board. (4cm x 4cm x 1.5mm)

Permanent device damage may occur if the above Absolute Maximum Ratings are exceeded. Functional operation should be restricted to the conditions as detailed in the operational sections of this data sheet. Exposure to absolute maximum rating conditions for extended periods may affect device reliability.

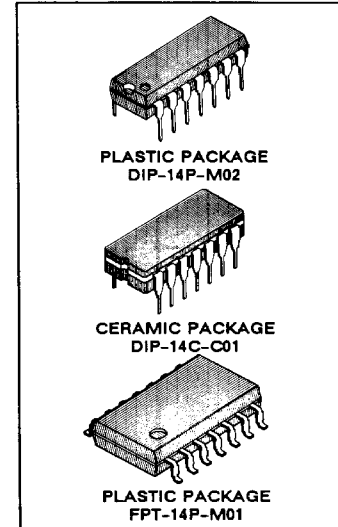

4

PIN ASSIGNMENT

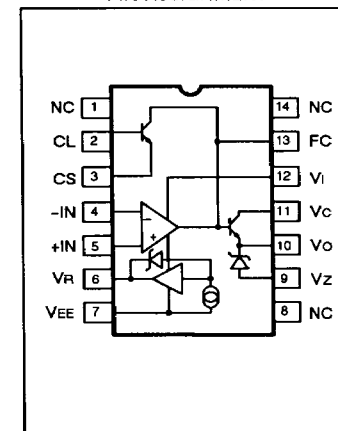

This device contains circuitry to protect the inputs against damage due to high static voltages or electric fields. However, it is advised that normal precautions be taken to avoid application of any voltage higher than maximum rated voltages to this high impedance circuit.

4

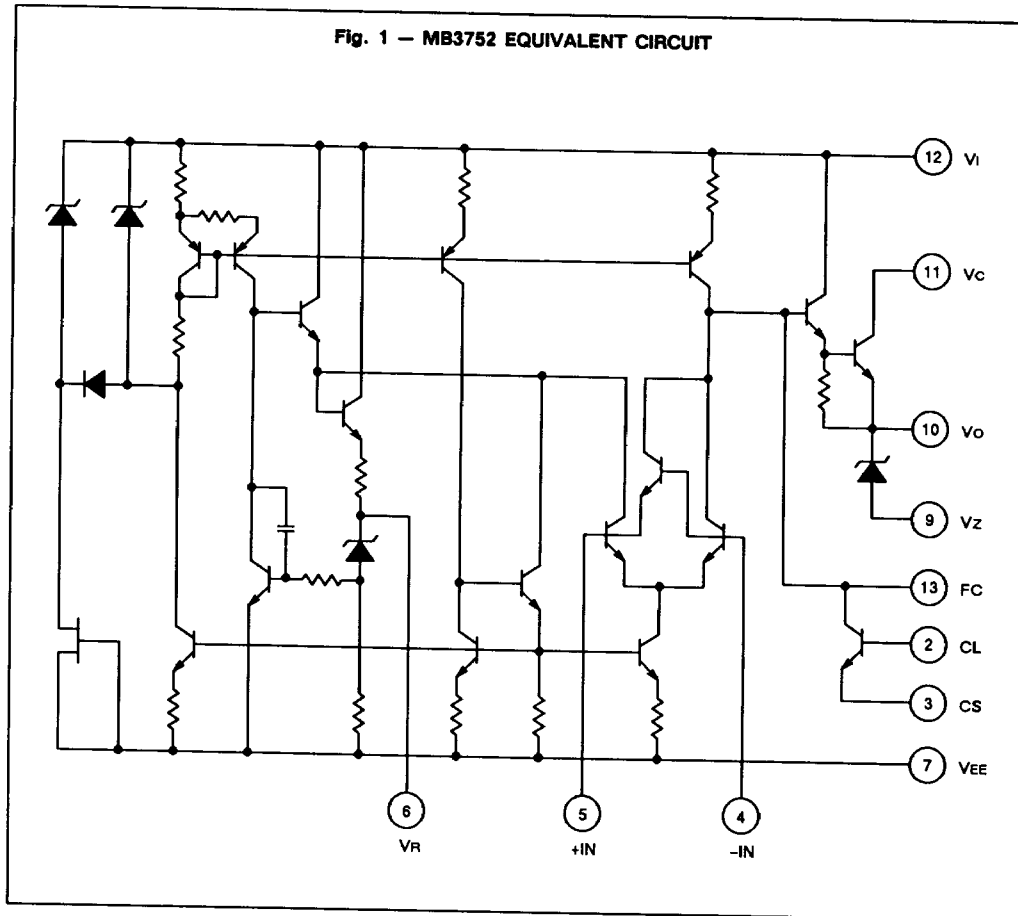

RECOMMENDED OPERATING CONDITIONS

Parameter	Symbol	Value	Unit
Input Voltage	V _{IN}	9.5 to 40	V
Load Current	I _L	1 to 50	mA
Operating Temperature	T _A	-20 to 75	°C

ELECTRICAL CHARACTERISTICS

(V_{IN} = 12 V, I_L = 1 mA, R_{SC} = 0, V_O = 5 V, T_A = 25°C)

Parameter	Symbol	Condition	Value			Unit
			Min	Typ	Max	
Input Voltage	V _{IN}		9.5		40	V
Output Voltage	V _O		2.0		37	V
Input-to-output Voltage Differential	V _{IN-V_O}		3.0		38	V
Bias Current	I _I	I _L = 0, V _{IN} = 30 V			4.0	mA
Reference Voltage	V _R		6.80	7.15	7.50	V
Input Regulation 1	R _{IN1}	12 V ≤ V _{IN} ≤ 15 V		0.01	0.1	%
Input Regulation 2	R _{IN2}	12 V ≤ V _{IN} ≤ 40 V		0.1	0.5	%
Input Regulation 3	R _{IN3}	12 V ≤ V _{IN} ≤ 15 V, 0°C ≤ T _A ≤ 70°C			0.3	%
Load Regulation 1	R _{LD1}	1 mA ≤ I _L ≤ 50 mA		0.03	0.2	%
Load Regulation 2	R _{LD2}	1 mA ≤ I _L ≤ 50 mA, 0°C ≤ T _A ≤ 70°C			0.6	%
Temperature Regulation	R _T	0°C ≤ T _A ≤ 70°C		0.2	1.0	%
Ripple Rejection Ratio	R.R.	f = 50 Hz to 10 kHz, C _R = 0		74		dB
		f = 50 Hz to 10 kHz, C _R = 5 μF		86		dB
Short Circuit Output Current	I _{SC}	V _O = 0, R _{SC} = 10 Ω	60	70	80	mA

4

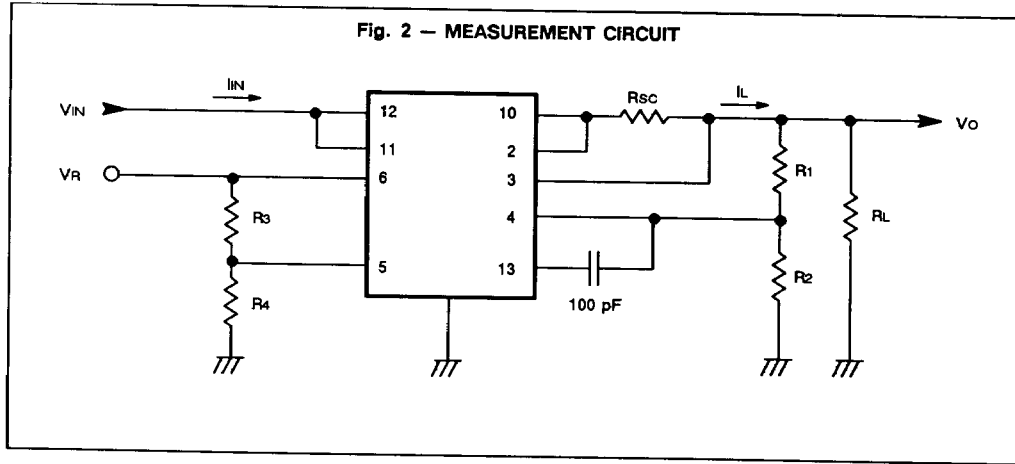

i) $2\text{ V} \leq V_O \leq V_R$ $V_O = V_R \frac{R_4}{R_3 + R_4}$, $R_1 = \frac{R_3 \cdot R_4}{R_3 + R_4}$, $R_2 = \infty$, $R_3 + R_4 \approx 7\text{ k}\Omega$

ii) $V_R \leq V_O \leq 37\text{ V}$ $V_O = V_R \left(1 + \frac{R_1}{R_2} \right)$, $R_3 = \frac{R_1 \cdot R_2}{R_1 + R_2}$, $R_4 = \infty$, $R_2 \approx 7\text{ k}\Omega$

iii) Equations for measurement items

a) $I_B = I_{IN} \left(\begin{array}{l} R_1 = 1.5\text{ k}, R_3 = 0, I_L = 0, \\ R_2 = \infty, R_4 = \infty, R_L = \infty \end{array} \right)$

b) $R_{IN1} = \frac{V_O(15\text{ V}) - V_O(12\text{ V})}{V_O(12\text{ V})} \times 100$

c) $R_{IN2} = \frac{V_O(40\text{ V}) - V_O(12\text{ V})}{V_O(12\text{ V})} \times 100$

d) $R_{LD} = \frac{V_O(1\text{ mA}) - V_O(50\text{ mA})}{V_O(1\text{ mA})} \times 100$

e) $I_{SC} = I_L$ ($R_L = 0$)

f) $R_T = \frac{V_O(\text{MAX}) - V_O(\text{MIN})}{V_O(25\text{ }^\circ\text{C})} \times 100$

Note: (b) to (f)
($V_O = 5\text{ V}$ setting, $R_1 = 1.5\text{ k}\Omega$, $R_2 = \infty$, $R_3 = 2.15\text{ k}\Omega$, $R_4 = 5\text{ k}\Omega$, $R_L = 5\text{ k}\Omega$)

TYPICAL CHARACTERISTICS CURVES

Fig. 3 - INPUT-TO-OUTPUT VOLTAGE DIFFERENTIAL vs. MAXIMUM LOAD CURRENT

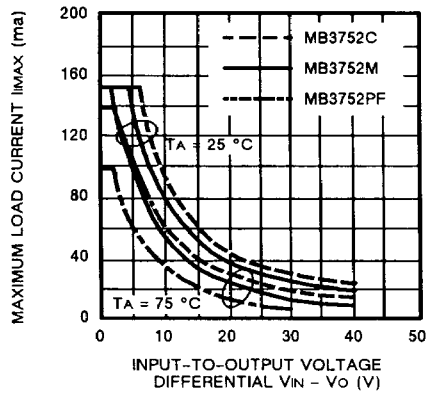

Fig. 4 - INPUT VOLTAGE vs. BIAS CURRENT

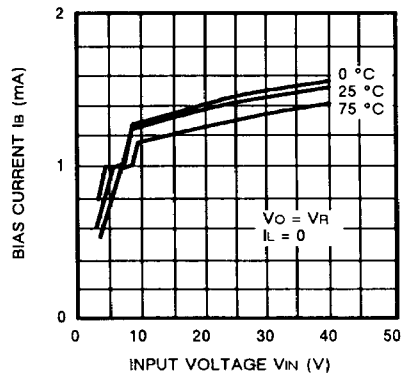

Fig. 5 - LOAD CURRENT vs. LOAD REGULATION

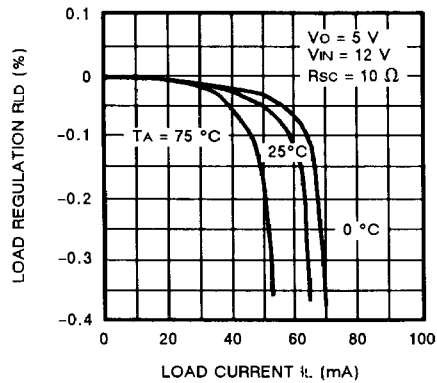
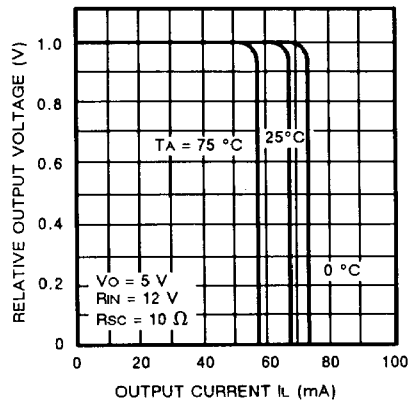

Fig. 6 - CURRENT LIMIT



4



MB3752

TYPICAL CHARACTERISTICS CURVES (Continued)

4

Fig. 7 - LOAD CURRENT vs. LOAD REGULATION

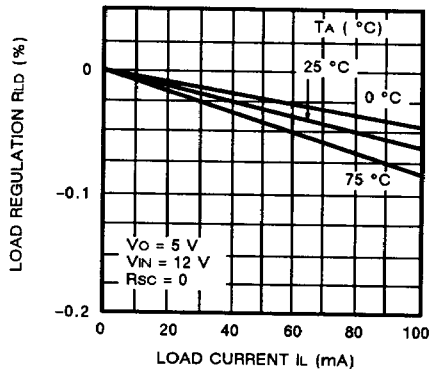

Fig. 8 - JUNCTION TEMPERATURE vs. CURRENT LIMIT SENSE VOLTAGE

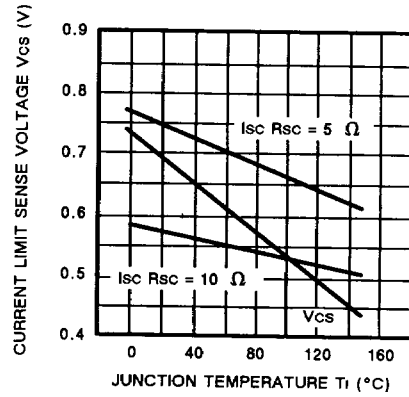

Fig. 9 - INPUT-TO-OUTPUT VOLTAGE DIFFERENTIAL vs. LINE REGULATION

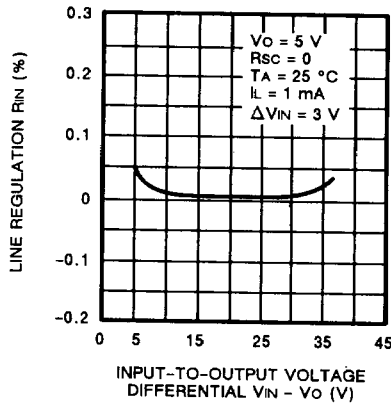
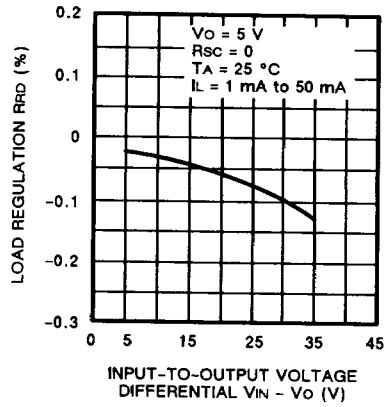

Fig. 10 - INPUT-TO-OUTPUT VOLTAGE DIFFERENTIAL vs. LOAD REGULATION



APPLICATION EXAMPLES

Fig. 11 - BASIC HIGH VOLTAGE REGULATOR

$$V_R \leq V_O \leq 37 \text{ V}$$

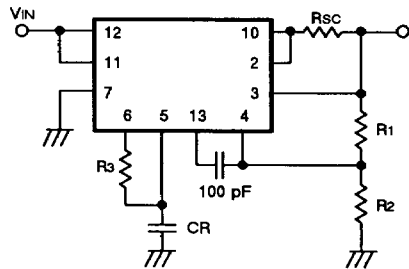

$$V_O = V_R \cdot \frac{R_1 + R_2}{R_2}$$

$$R_3 = \frac{R_1 \cdot R_2}{R_1 + R_2} \text{ for minimum temperature drift}$$

Fig. 12 - BASIC LOW VOLTAGE REGULATOR

$$2 \text{ V} \leq V_O \leq V_R$$

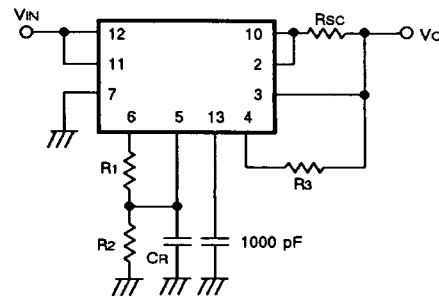

$$V_O = V_R \cdot \frac{R_2}{R_1 + R_2}$$

$$R_3 = \frac{R_1 \cdot R_2}{R_1 + R_2} \text{ for minimum temperature drift}$$

Fig. 13 - FOLDBACK CURRENT LIMITING REGULATOR

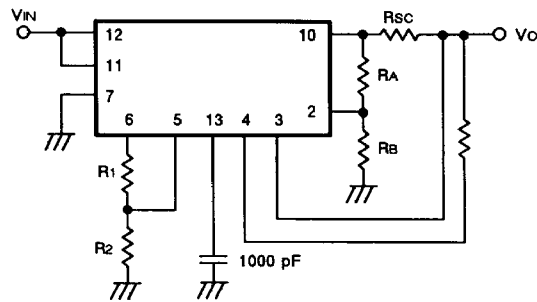

$$I_L \leq I_K \quad V_O = V_R \cdot \frac{R_2}{R_1 + R_2}$$

$$R_3 = \frac{R_1 \cdot R_2}{R_1 + R_2} \text{ for minimum temperature drift}$$

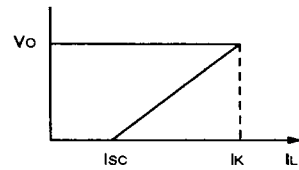

$$V_O = \frac{R_B \cdot R_{SC}}{R_A} \cdot I_L - V_{SC} \left(1 + \frac{R_B}{R_A} \right)$$

$$I_{SC} = \frac{V_{SC}}{R_{SC}} \cdot \left(1 + \frac{R_A}{R_B} \right), \quad V_{SC} \approx 0.7 \text{ V}$$

$$I_K = I_{SC} + \frac{V_O}{R_{SC}} \cdot \frac{R_A}{R_B}$$

4



MB3752

APPLICATION EXAMPLES (Continued)

4

Fig. 14 - POSITIVE VOLTAGE REGULATOR NPN TRANSISTOR

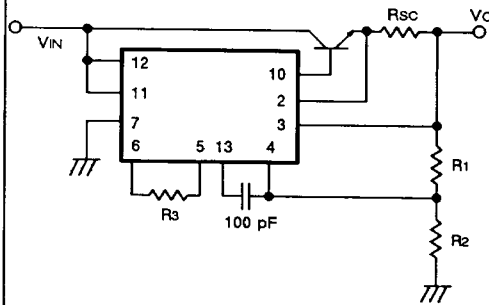

$$V_o = V_R \cdot \frac{R_1 + R_2}{R_2}$$

$$R_3 = \frac{R_1 \cdot R_2}{R_1 + R_2} \text{ for minimum temperature drift}$$

Fig. 15 - POSITIVE VOLTAGE REGULATOR PNP TRANSISTOR

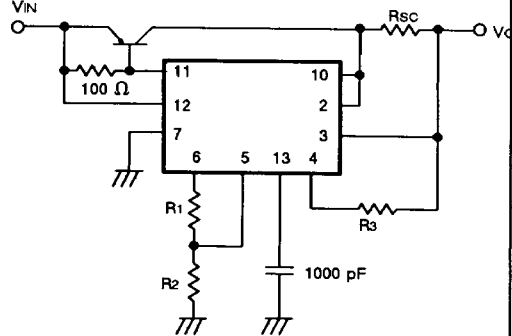

$$V_o = V_R \cdot \frac{R_2}{R_1 + R_2}$$

$$R_3 = \frac{R_1 \cdot R_2}{R_1 + R_2} \text{ for minimum temperature drift}$$

Fig. 16 - NEGATIVE VOLTAGE REGULATOR

$$|V_o| \geq 9.5 \text{ V}$$

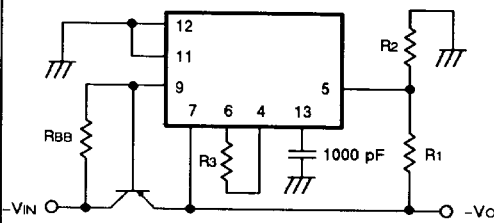

$$V_o = V_R \cdot \left(1 + \frac{R_2}{R_1}\right)$$

$$R_3 = \frac{R_1 \cdot R_2}{R_1 + R_2} \text{ for minimum temperature drift}$$

Fig. 17 - NEGATIVE VOLTAGE REGULATOR

$$0 \leq |V_o| \leq V_R$$

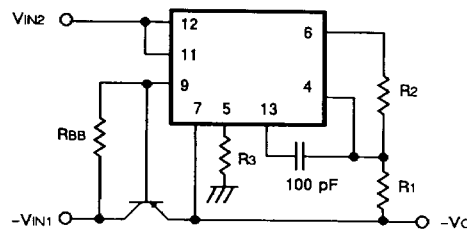

$$V_o = \frac{V_R}{(1 + R_2/R_1)}, \text{ } V_{IN2} + V_o \geq 9.5 \text{ V}$$

$$R_3 = \frac{R_1 \cdot R_2}{R_1 + R_2} \text{ for minimum temperature drift}$$

APPLICATION EXAMPLES (Continued)

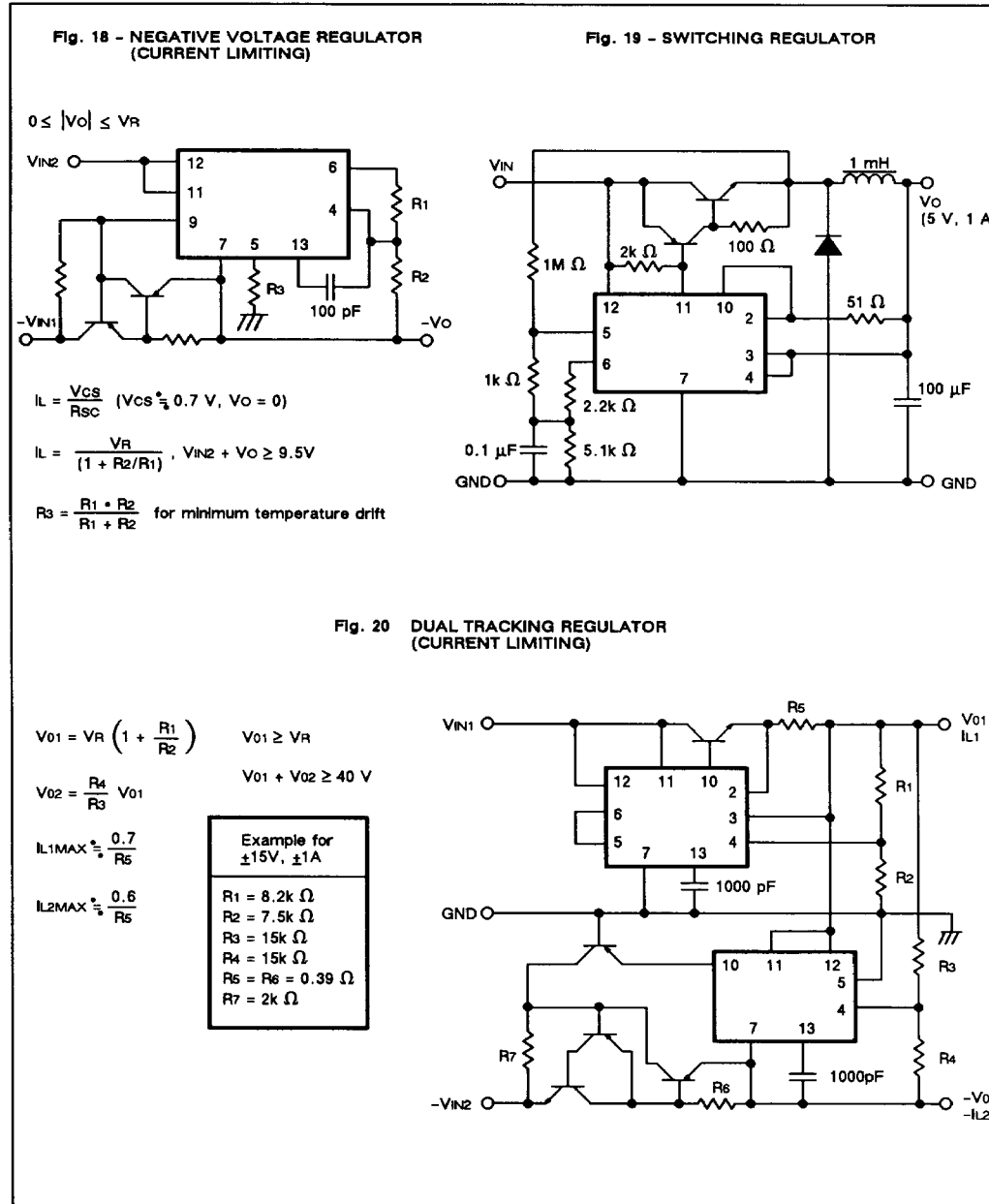

APPLICATION EXAMPLES (Continued)

4

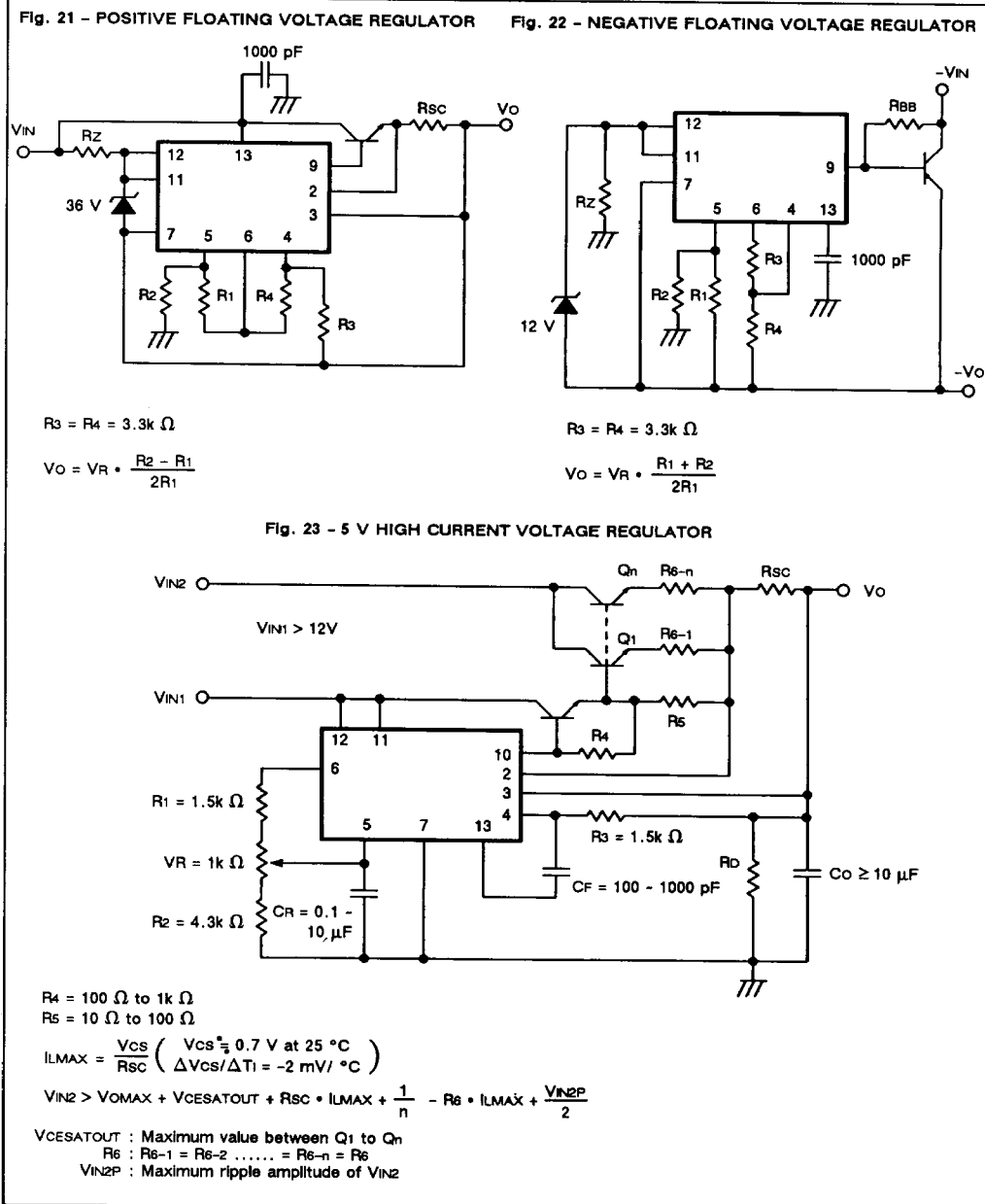

PACKAGE DIMENSIONS

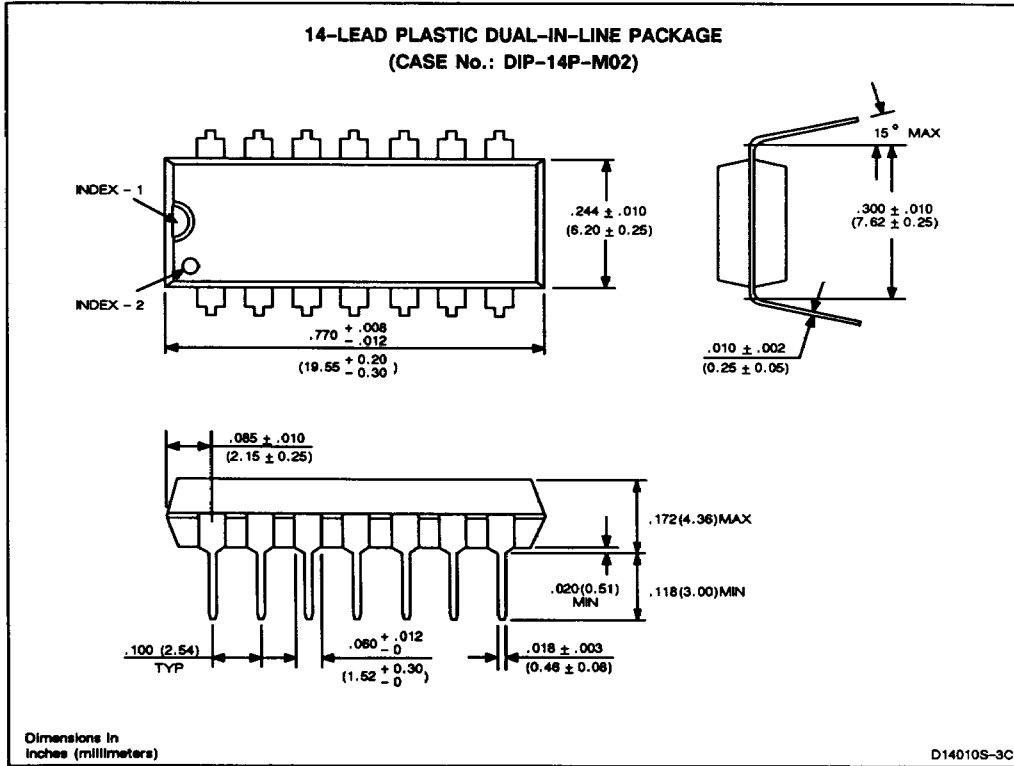

4

PACKAGE DIMENSIONS (Continued)

4

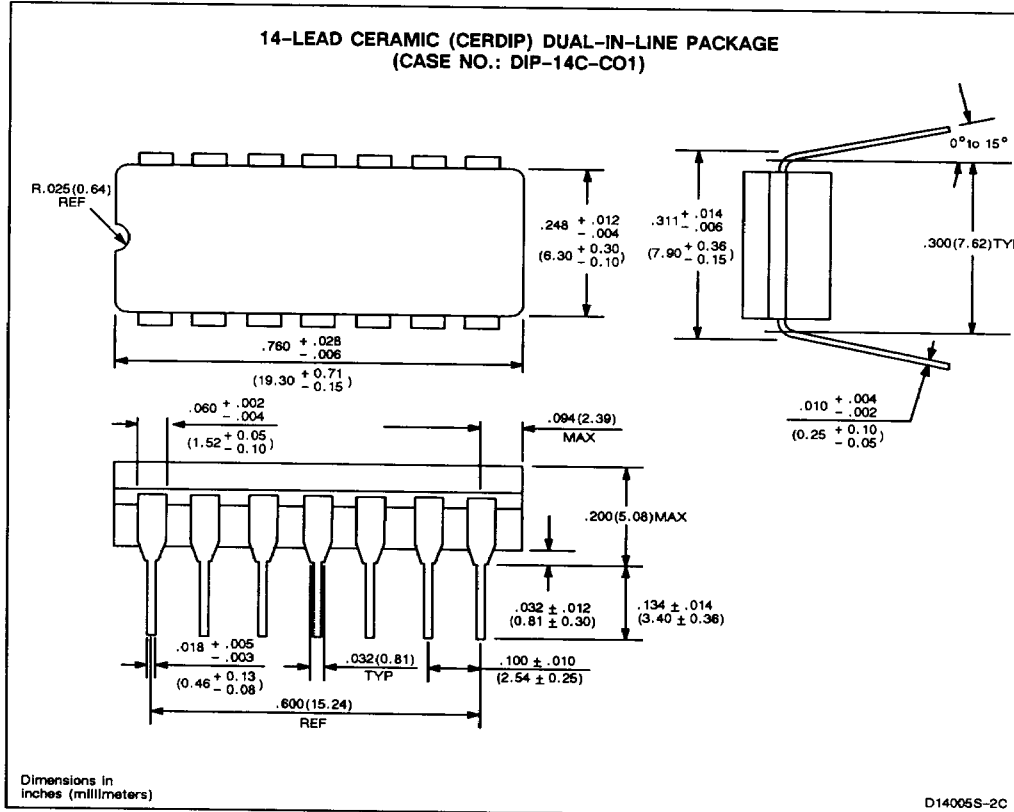

PACKAGE DIMENSIONS (Continued)

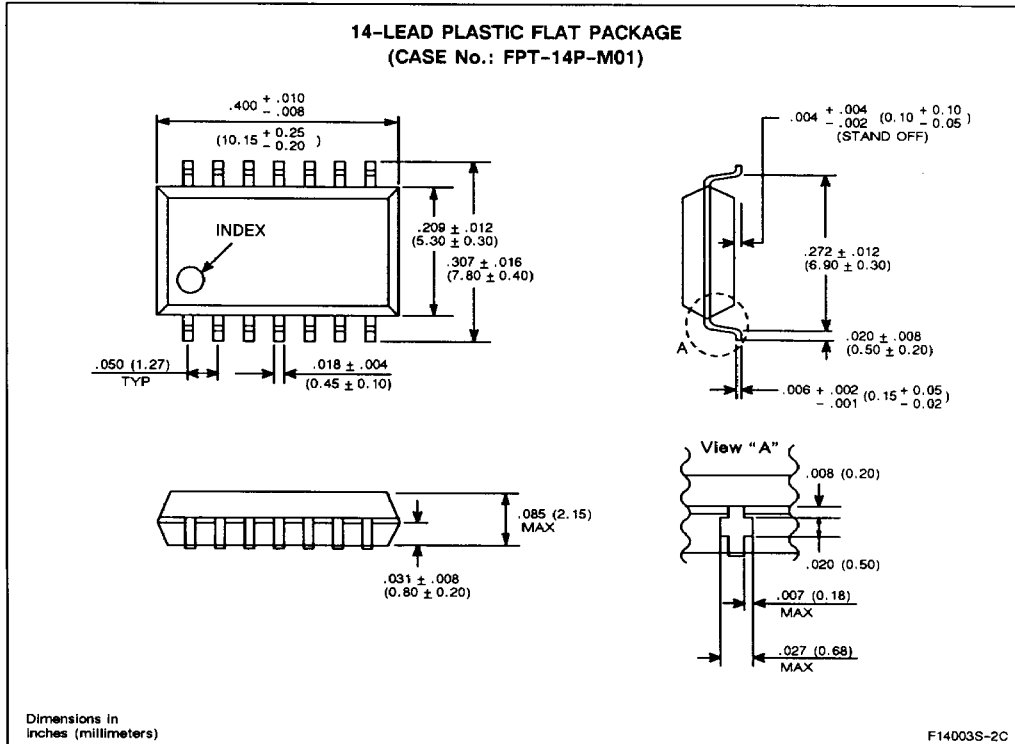

4