

## Surface Mount Glass Passivated Ultrafast Rectifier

### SUPERECTIFIER®



DO-214BA (GF1)

### FEATURES

- Superectifier structure for high reliability condition
- Cavity-free glass-passivated junction
- Ideal for automated placement
- Ultrafast reverse recovery time
- Low switching losses, high efficiency
- Avalanche surge energy capability
- Meets environmental standard MIL-S-19500
- Meets MSL level 1, per J-STD-020, LF maximum peak of 250 °C
- AEC-Q101 qualified
- Compliant to RoHS Directive 2002/95/EC and in accordance to WEEE 2002/96/EC



RoHS  
COMPLIANT

### PRIMARY CHARACTERISTICS

$I_{F(AV)}$	1.0 A
$V_{RRM}$	1300 V
$I_{FSM}$	20 A
$t_{rr}$	75 ns
$E_{AS}$	15 mJ
$T_J \text{ max.}$	150 °C

### TYPICAL APPLICATIONS

For use in high voltage rectification of photoflash application.

### MECHANICAL DATA

**Case:** DO-214BA, molded plastic over glass body  
Molding compound meets UL 94 V-0 flammability rating  
Base P/N-E3 - RoHS compliant, commercial grade  
Base P/NHE3 - RoHS compliant, AEC-Q101 qualified

**Terminals:** Matte tin plated leads, solderable per J-STD-002 and JESD 22-B102

E3 suffix meets JESD 201 class 1A whisker test, HE3 suffix meets JESD 201 class 2 whisker test

**Polarity:** Color band denotes cathode end

### MAXIMUM RATINGS ( $T_A = 25\text{ °C}$ unless otherwise noted)

PARAMETER	SYMBOL	EGF1T	UNIT
Device marking code		ET	
Maximum repetitive peak reverse voltage	$V_{RRM}$	1300	V
Maximum RMS voltage	$V_{RMS}$	910	V
Maximum DC blocking	$V_{DC}$	1300	V
Maximum average forward rectified current	$I_{F(AV)}$	1.0	A
Peak forward surge current 8.3 ms single half sine-wave superimposed on rated load	$I_{FSM}$	20	A
Non-repetitive avalanche energy at $T_A = 25\text{ °C}$ , $I_{AS} = 1\text{ A}$ , $L = 30\text{ mH}$	$E_{AS}$	15	mJ
Operating junction and storage temperature range	$T_J, T_{STG}$	- 55 to + 150	°C

**ELECTRICAL CHARACTERISTICS** ( $T_A = 25\text{ }^\circ\text{C}$  unless otherwise noted)

PARAMETER	TEST CONDITIONS		SYMBOL	EGF1T	UNIT
Maximum instantaneous forward voltage	1.0 A	$T_J = 25\text{ }^\circ\text{C}$	$V_F^{(1)}$	3.0	V
Maximum DC reverse current	$V_{RM}$	$T_J = 25\text{ }^\circ\text{C}$	$I_R^{(2)}$	5.0	$\mu\text{A}$
		$T_J = 125\text{ }^\circ\text{C}$		50	
Typical reverse recovery time	$I_F = 0.5\text{ A}$ , $I_R = 1.0\text{ A}$ , $I_{rr} = 0.25\text{ A}$		$t_{rr}$	75	ns
Typical junction capacitance	4.0 V, 1 MHz		$C_J$	8.0	pF

**Notes**(1) Pulse test: 300  $\mu\text{s}$  pulse width, 1 % duty cycle(2) Pulse test: Pulse width  $\leq 40\text{ ms}$ **THERMAL CHARACTERISTICS** ( $T_A = 25\text{ }^\circ\text{C}$  unless otherwise noted)

PARAMETER	SYMBOL	EGF1T	UNIT
Typical thermal resistance	$R_{\theta JA}^{(1)}$	50	$^\circ\text{C/W}$
	$R_{\theta JL}^{(1)}$	20	

**Note**

(1) Thermal resistance from junction to ambient and from junction to lead, PCB mounted on 0.95" x 0.95" (24 mm x 24 mm) copper pad areas

**ORDERING INFORMATION** (Example)

PREFERRED P/N	UNIT WEIGHT (g)	PREFERRED PACKAGE CODE	BASE QUANTITY	DELIVERY MODE
EGF1T-E3/67A	0.104	67A	1500	7" diameter plastic tape and reel
EGF1T-E3/5CA	0.104	5CA	6500	13" diameter plastic tape and reel
EGF1THE3/67A <sup>(1)</sup>	0.104	67A	1500	7" diameter plastic tape and reel
EGF1THE3/5CA <sup>(1)</sup>	0.104	5CA	6500	13" diameter plastic tape and reel

**Note**

(1) AEC-Q101 qualified

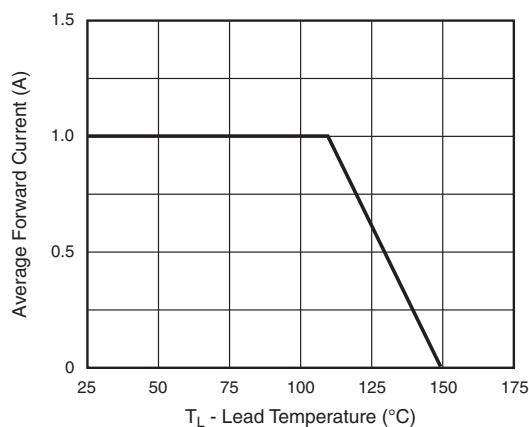
**RATINGS AND CHARACTERISTICS CURVES**( $T_A = 25\text{ }^\circ\text{C}$  unless otherwise noted)

Fig. 1 - Maximum Forward Current Derating Curve

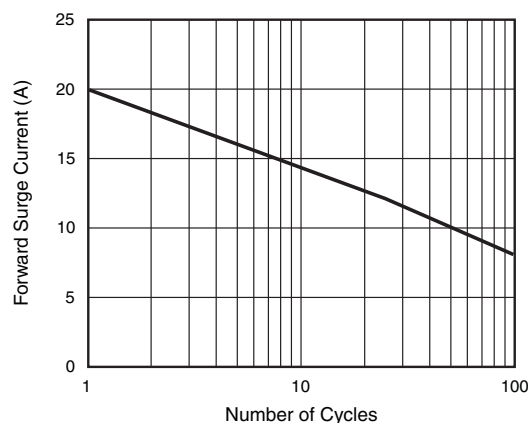


Fig. 2 - Maximum Non-Repetitive Forward Surge Current

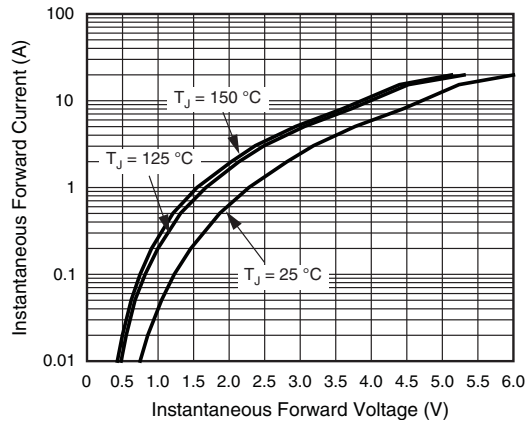


Fig. 3 - Typical Instantaneous Forward Characteristics

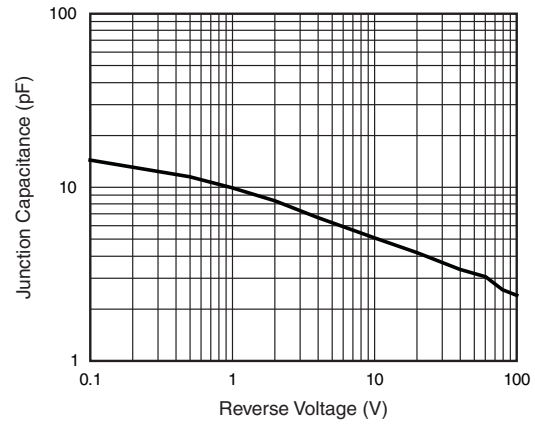


Fig. 5 - Typical Junction Capacitance Per Leg

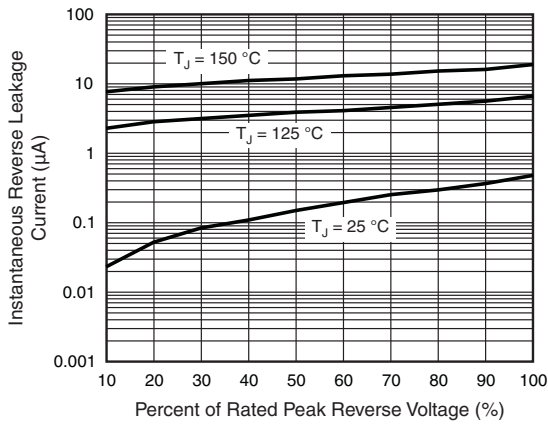


Fig. 4 - Typical Reverse Leakage Characteristics

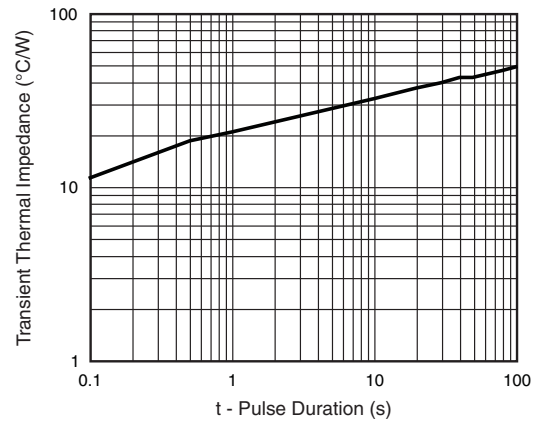
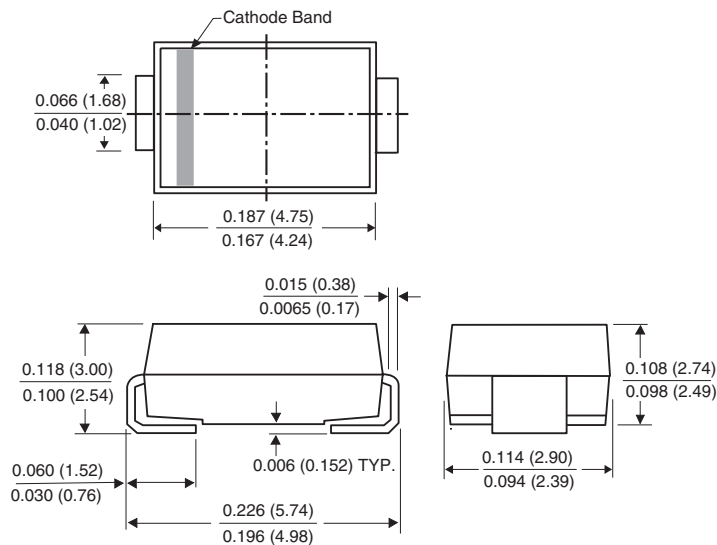


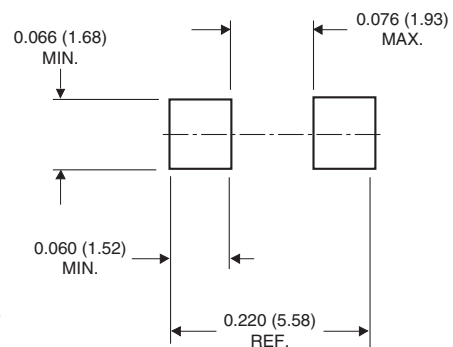
Fig. 6 - Typical Transient Thermal Impedance

**PACKAGE OUTLINE DIMENSIONS** in inches (millimeters)

**DO-214BA (GF1)**



**Mounting Pad Layout**





## Disclaimer

ALL PRODUCT, PRODUCT SPECIFICATIONS AND DATA ARE SUBJECT TO CHANGE WITHOUT NOTICE TO IMPROVE RELIABILITY, FUNCTION OR DESIGN OR OTHERWISE.

Vishay Intertechnology, Inc., its affiliates, agents, and employees, and all persons acting on its or their behalf (collectively, "Vishay"), disclaim any and all liability for any errors, inaccuracies or incompleteness contained in any datasheet or in any other disclosure relating to any product.

Vishay makes no warranty, representation or guarantee regarding the suitability of the products for any particular purpose or the continuing production of any product. To the maximum extent permitted by applicable law, Vishay disclaims (i) any and all liability arising out of the application or use of any product, (ii) any and all liability, including without limitation special, consequential or incidental damages, and (iii) any and all implied warranties, including warranties of fitness for particular purpose, non-infringement and merchantability.

Statements regarding the suitability of products for certain types of applications are based on Vishay's knowledge of typical requirements that are often placed on Vishay products in generic applications. Such statements are not binding statements about the suitability of products for a particular application. It is the customer's responsibility to validate that a particular product with the properties described in the product specification is suitable for use in a particular application. Parameters provided in datasheets and/or specifications may vary in different applications and performance may vary over time. All operating parameters, including typical parameters, must be validated for each customer application by the customer's technical experts. Product specifications do not expand or otherwise modify Vishay's terms and conditions of purchase, including but not limited to the warranty expressed therein.

Except as expressly indicated in writing, Vishay products are not designed for use in medical, life-saving, or life-sustaining applications or for any other application in which the failure of the Vishay product could result in personal injury or death. Customers using or selling Vishay products not expressly indicated for use in such applications do so at their own risk and agree to fully indemnify and hold Vishay and its distributors harmless from and against any and all claims, liabilities, expenses and damages arising or resulting in connection with such use or sale, including attorneys fees, even if such claim alleges that Vishay or its distributor was negligent regarding the design or manufacture of the part. Please contact authorized Vishay personnel to obtain written terms and conditions regarding products designed for such applications.

No license, express or implied, by estoppel or otherwise, to any intellectual property rights is granted by this document or by any conduct of Vishay. Product names and markings noted herein may be trademarks of their respective owners.