

Transcend Industrial CF Card (128MB ~ 8GB)

Description

The Transcend 128MB ~ 8GB CFI is an industrial CompactFlash Card with Industrial Flash Memory assembled on a printed circuit board.

Placement

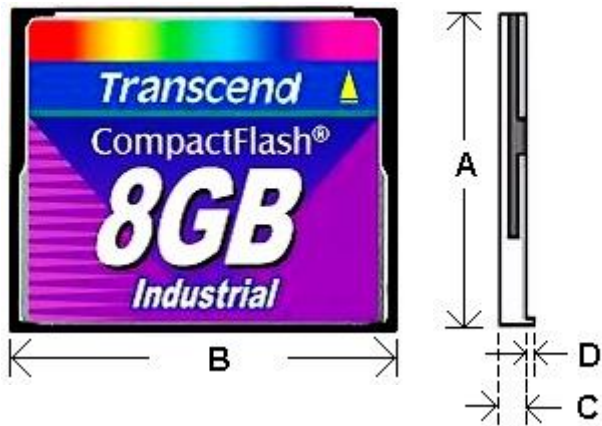

■ Dimensions

Side	Millimeters	Inches
A	36.40 ± 0.150	1.43 ± 0.005
B	42.80 ± 0.100	1.69 ± 0.004
C	3.30 ± 0.100	0.13 ± 0.004
D	0.63 ± 0.070	0.02 ± 0.003

Features

- CompactFlash Specification Version 3.0 Complaint
- RoHS compliant products
- Single Power Supply: $3.3V \pm 5\%$ or $5V \pm 10\%$
- Operating Temperature: -40°C to 85°C
- Storage Temperature: -55°C to 100°C
- Operation Modes:
 - ✓ PC Card Memory Mode
 - ✓ PC Card IO Mode
 - ✓ True IDE Mode
- True IDE Mode supports PIO mode 0~4 (Series of -D support Ultra DMA mode 4, please see Order Information)
- Endurance: 2,000,000 Program/Erase cycles
- MTBF: 1,000,000 hours
- Durability of Connector: 10,000 times
- High Data Reliability based on the internal 4-bits ECC (Error Correcting Code) function
- Support Wear-leveling algorithm

Transcend Industrial CF Card (128MB ~ 8GB)

■ Order Information

	Part Number	Interface	Transfer mode	Description
CF45I	TS128M~8GCF45I	True IDE mode	PIO mode 0~4	Non-DMA Fixed Disk
		PC card mode (PCMCIA)	80ns, 100ns, 120ns, 250ns	Non-DMA Removable Disk
	TS128M~8GCF45I-D	True IDE mode	Ultra DMA mode 0~4 Multiword DMA 0~4 PIO mode 0~6	Ultra-DMA Fixed Disk
		PC card mode (PCMCIA)	80ns, 100ns, 120ns, 250ns	Non-DMA Removable Disk

C.H.S. Table

This table shows default number of cylinders, heads and sectors for the various models.

Capacity	C	H	S
128MB	978	8	32
256MB	978	16	32
512MB	993	16	63
1GB	1985	16	63
2GB	3954	16	63
4GB	7889	16	63
8GB	15778	16	63

Transcend Industrial CF Card (128MB ~ 8GB)

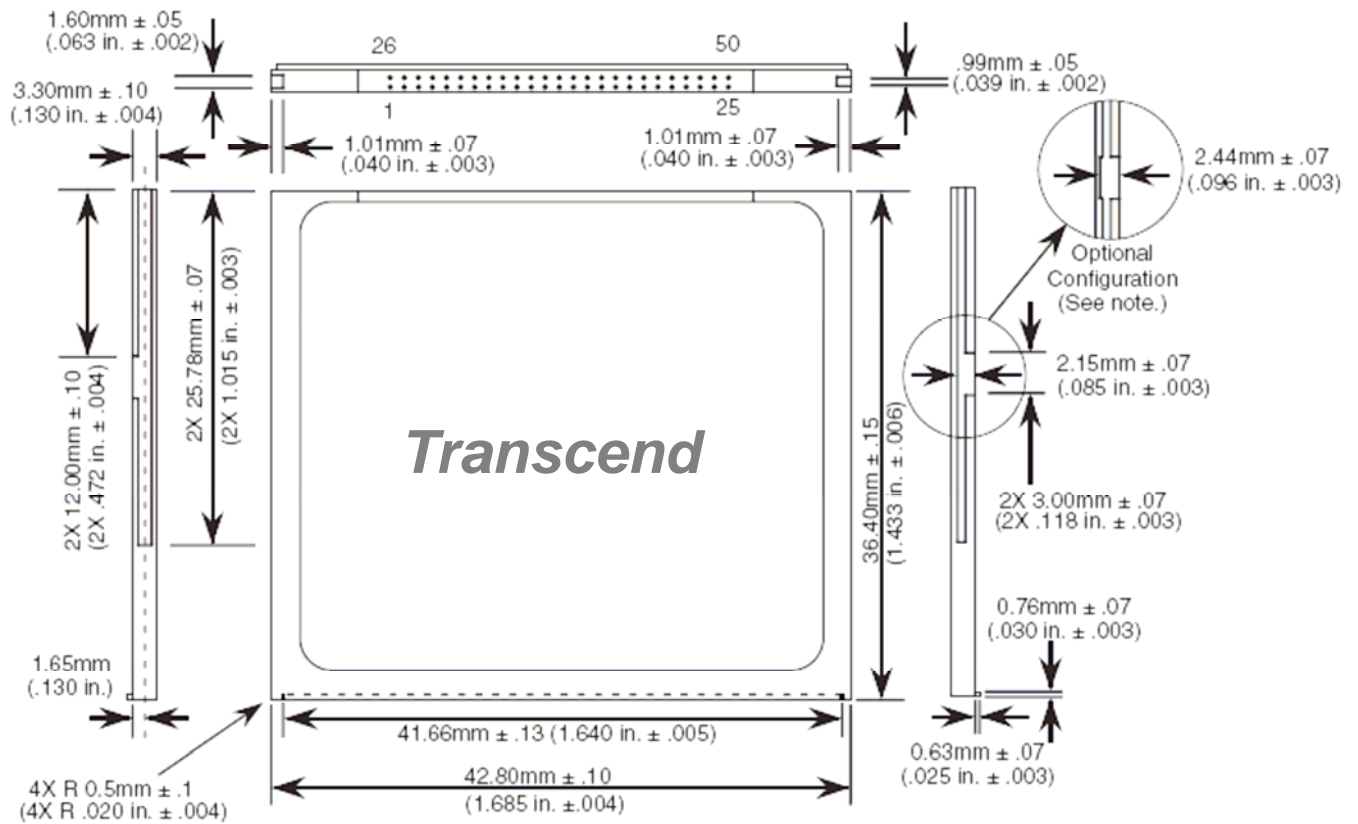

Transcend Industrial CF Card (128MB ~ 8GB)

Block Diagram

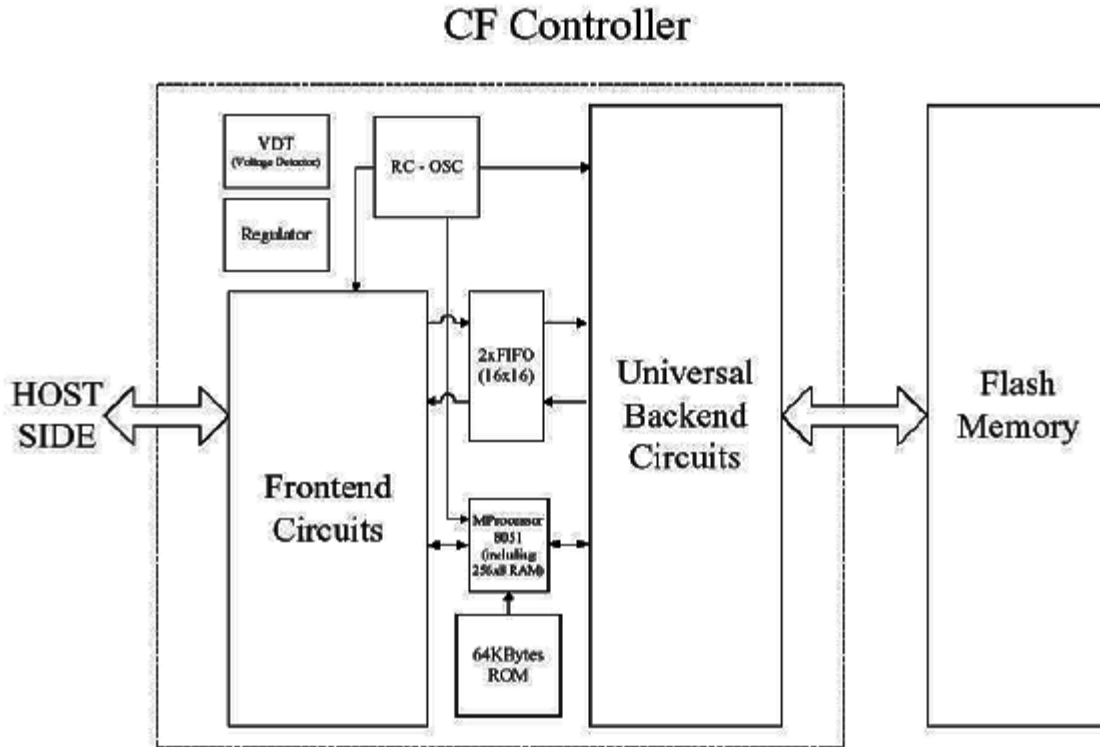

Transcend Industrial CF Card (128MB ~ 8GB)

Pin Assignments and Pin Type

PC Card Memory Mode				PC Card I/O Mode				True IDE Mode ⁴			
Pin Num	Signal Name	Pin Type	In, Out Type	Pin Num	Signal Name	Pin Type	In, Out Type	Pin Num	Signal Name	Pin Type	In, Out Type
1	GND		Ground	1	GND		Ground	1	GND		Ground
2	D03	I/O	I1Z, OZ3	2	D03	I/O	I1Z, OZ3	2	D03	I/O	I1Z, OZ3
3	D04	I/O	I1Z, OZ3	3	D04	I/O	I1Z, OZ3	3	D04	I/O	I1Z, OZ3
4	D05	I/O	I1Z, OZ3	4	D05	I/O	I1Z, OZ3	4	D05	I/O	I1Z, OZ3
5	D06	I/O	I1Z, OZ3	5	D06	I/O	I1Z, OZ3	5	D06	I/O	I1Z, OZ3
6	D07	I/O	I1Z, OZ3	6	D07	I/O	I1Z, OZ3	6	D07	I/O	I1Z, OZ3
7	-CE1	I	I3U	7	-CE1	I	I3U	7	-CS0	I	I3Z
8	A10	I	I1Z	8	A10	I	I1Z	8	A10 ²	I	I1Z
9	-OE	I	I3U	9	-OE	I	I3U	9	-ATA SEL	I	I3U
10	A09	I	I1Z	10	A09	I	I1Z	10	A09 ²	I	I1Z
11	A08	I	I1Z	11	A08	I	I1Z	11	A08 ²	I	I1Z
12	A07	I	I1Z	12	A07	I	I1Z	12	A07 ²	I	I1Z
13	VCC		Power	13	VCC		Power	13	VCC		Power
14	A06	I	I1Z	14	A06	I	I1Z	14	A06 ²	I	I1Z
15	A05	I	I1Z	15	A05	I	I1Z	15	A05 ²	I	I1Z
16	A04	I	I1Z	16	A04	I	I1Z	16	A04 ²	I	I1Z
17	A03	I	I1Z	17	A03	I	I1Z	17	A03 ²	I	I1Z
18	A02	I	I1Z	18	A02	I	I1Z	18	A02	I	I1Z
19	A01	I	I1Z	19	A01	I	I1Z	19	A01	I	I1Z
20	A00	I	I1Z	20	A00	I	I1Z	20	A00	I	I1Z
21	D00	I/O	I1Z, OZ3	21	D00	I/O	I1Z, OZ3	21	D00	I/O	I1Z, OZ3
22	D01	I/O	I1Z, OZ3	22	D01	I/O	I1Z, OZ3	22	D01	I/O	I1Z, OZ3
23	D02	I/O	I1Z, OZ3	23	D02	I/O	I1Z, OZ3	23	D02	I/O	I1Z, OZ3
24	WP	O	OT3	24	-IOIS16	O	OT3	24	-IOCS16	O	ON3
25	-CD2	O	Ground	25	-CD2	O	Ground	25	-CD2	O	Ground
26	-CD1	O	Ground	26	-CD1	O	Ground	26	-CD1	O	Ground
27	D11 ¹	I/O	I1Z, OZ3	27	D11 ¹	I/O	I1Z, OZ3	27	D11 ¹	I/O	I1Z, OZ3
28	D12 ¹	I/O	I1Z, OZ3	28	D12 ¹	I/O	I1Z, OZ3	28	D12 ¹	I/O	I1Z, OZ3
29	D13 ¹	I/O	I1Z, OZ3	29	D13 ¹	I/O	I1Z, OZ3	29	D13 ¹	I/O	I1Z, OZ3
30	D14 ¹	I/O	I1Z, OZ3	30	D14 ¹	I/O	I1Z, OZ3	30	D14 ¹	I/O	I1Z, OZ3
31	D15 ¹	I/O	I1Z, OZ3	31	D15 ¹	I/O	I1Z, OZ3	31	D15 ¹	I/O	I1Z, OZ3
32	-CE2 ¹	I	I3U	32	-CE2 ¹	I	I3U	32	-CS1 ¹	I	I3Z
33	-VS1	O	Ground	33	-VS1	O	Ground	33	-VS1	O	Ground
34	-IORD	I	I3U	34	-IORD	I	I3U	34	-IORD ⁷	I	I3Z
									HSTROBE ⁸		
									-HDMARDY ⁹		

Transcend Industrial CF Card (128MB ~ 8GB)

PC Card Memory Mode				PC Card I/O Mode				True IDE Mode ⁴			
Pin Num	Signal Name	Pin Type	In, Out Type	Pin Num	Signal Name	Pin Type	In, Out Type	Pin Num	Signal Name	Pin Type	In, Out Type
35	-IOWR	I	I3U	35	-IOWR	I	I3U	35	-IOWR ⁷	I	I3Z
									STOP ^{8,9}		
36	-WE	I	I3U	36	-WE	I	I3U	36	-WE ³	I	I3U
37	READY	O	OT1	37	-IREQ	O	OT1	37	INTRQ	O	OZ1
38	VCC		Power	38	VCC		Power	38	VCC		Power
39	-CSEL ⁵	I	I2Z	39	-CSEL ⁵	I	I2Z	39	-CSEL	I	I2U
40	-VS2	O	OPEN	40	-VS2	O	OPEN	40	-VS2	O	OPEN
41	RESET	I	I2Z	41	RESET	I	I2Z	41	-RESET	I	I2Z
42	-WAIT	O	OT1	42	-WAIT	O	OT1	42	IORDY ⁷	O	ON1
									-DDMARDY ⁶		
									DSTROBE ⁹		
43	-INPACK	O	OT1	43	-INPACK	O	OT1	43	DMARQ	O	OZ1
44	-REG	I	I3U	44	-REG	I	I3U	44	-DMACK ⁶	I	I3U
45	BVD2	O	OT1	45	-SPKR	O	OT1	45	-DASP	I/O	I1U, ON1
46	BVD1	O	OT1	46	-STSCHG	O	OT1	46	-PDIAG	I/O	I1U, ON1
47	D08 ¹	I/O	I1Z, OZ3	47	D08 ¹	I/O	I1Z, OZ3	47	D08 ¹	I/O	I1Z, OZ3
48	D09 ¹	I/O	I1Z, OZ3	48	D09 ¹	I/O	I1Z, OZ3	48	D09 ¹	I/O	I1Z, OZ3
49	D10 ¹	I/O	I1Z, OZ3	49	D10 ¹	I/O	I1Z, OZ3	49	D10 ¹	I/O	I1Z, OZ3
50	GND		Ground	50	GND		Ground	50	GND		Ground

- Note:
- 1) These signals are required only for 16 bit accesses and not required when installed in 8 bit systems. Devices should allow for 3-state signals not to consume current.
 - 2) The signal should be grounded by the host.
 - 3) The signal should be tied to VCC by the host.
 - 4) The mode is optional for CF+ Cards, but required for CompactFlash Storage Cards.
 - 5) The -CSEL signal is ignored by the card in PC Card modes. However, because it is not pulled upon the card in these modes, it should not be left floating by the host in PC Card modes. In these modes, the pin should be connected by the host to PC Card A25 or grounded by the host.
 - 6) If DMA operations are not used, the signal should be held high or tied to VCC by the host. For proper operation in older hosts: while DMA operations are not active, the card shall ignore this signal, including a floating condition
 - 7) Signal usage in True IDE Mode except when Ultra DMA mode protocol is active.
 - 8) Signal usage in True IDE Mode when Ultra DMA mode protocol DMA Write is active.
 - 9) Signal usage in True IDE Mode when Ultra DMA mode protocol DMA Read is active.

Transcend Industrial CF Card (128MB ~ 8GB)

Signal Description

Signal Name	Dir.	Pin	Description
A10 - A0 (PC Card Memory Mode)	I	8,10,11,12, 14,15,16,17, 18,19,20	These address lines along with the -REG signal are used to select the following: The I/O port address registers within the CompactFlash Storage Card or CF+ Card, the memory mapped port address registers within the CompactFlash Storage Card or CF+ Card, a byte in the card's information structure and its configuration control and status registers. This signal is the same as the PC Card Memory Mode signal.
A10 - A0 (PC Card I/O Mode)			
A2 - A0 (True IDE Mode)	I	18,19,20	In True IDE Mode, only A[2:0] are used to select the one of eight registers in the Task File, the remaining address lines should be grounded by the host.
BVD1 (PC Card Memory Mode)	I/O	46	This signal is asserted high, as BVD1 is not supported. This signal is asserted low to alert the host to changes in the READY and Write Protect states, while the I/O interface is configured. Its use is controlled by the Card Config and Status Register.
-STSCHG (PC Card I/O Mode) Status Changed			
-PDIAG (True IDE Mode)			In the True IDE Mode, this input / output is the Pass Diagnostic signal in the Master / Slave handshake protocol.
BVD2 (PC Card Memory Mode)	I/O	45	This signal is asserted high, as BVD2 is not supported. This line is the Binary Audio output from the card. If the Card does not support the Binary Audio function, this line should be held negated.
-SPKR (PC Card I/O Mode)			
-DASP (True IDE Mode)			In the True IDE Mode, this input/output is the Disk Active/Slave Present signal in the Master/Slave handshake protocol.
-CD1, -CD2 (PC Card Memory Mode)	O	26,25	These Card Detect pins are connected to ground on the CompactFlash Storage Card or CF+ Card. They are used by the host to determine that the CompactFlash Storage Card or CF+ Card is fully inserted into its socket. This signal is the same for all modes.
-CD1, -CD2 (PC Card I/O Mode)			
-CD1, -CD2 (True IDE Mode)			This signal is the same for all modes.
-CE1, -CE2 (PC Card Memory Mode) Card Enable	I	7,32	These input signals are used both to select the card and to indicate to the card whether a byte or a word operation is being performed. -CE2 always accesses the odd byte of the word. -CE1 accesses the even byte or the Odd byte of the word depending on A0 and -CE2. A multiplexing scheme based on A0, -CE1, -CE2 allows 8 bit hosts to access all data on D0-D7. This signal is the same as the PC Card Memory Mode signal.
-CE1, -CE2 (PC Card I/O Mode) Card Enable			
-CS0, -CS1 (True IDE Mode)			In the True IDE Mode, -CS0 is the chip select for the task file registers while -CS1 is used to select the Alternate Status Register and the Device Control Register. While -DMACK is asserted, -CS0 and -CS1 shall be held negated and the width of the transfers shall be 16 bits.

Transcend Industrial CF Card (128MB ~ 8GB)

Signal Name	Dir.	Pin	Description
-CSEL (PC Card Memory Mode)	I	39	This signal is not used for this mode, but should be connected by the host to PC Card A25 or grounded by the host.
-CSEL (PC Card I/O Mode)			This signal is not used for this mode, but should be connected by the host to PC Card A25 or grounded by the host.
-CSEL (True IDE Mode)			This internally pulled up signal is used to configure this device as a Master or a Slave when configured in the True IDE Mode. When this pin is grounded, this device is configured as a Master. When the pin is open, this device is configured as a Slave.
D15 - D00 (PC Card Memory Mode)	I/O	31,30,29,28, 27,49,48,47, 6,5,4,3,2, 23, 22, 21	These lines carry the Data, Commands and Status information between the host and the controller. D00 is the LSB of the Even Byte of the Word. D08 is the LSB of the Odd Byte of the Word.
D15 - D00 (PC Card I/O Mode)			This signal is the same as the PC Card Memory Mode signal.
D15 - D00 (True IDE Mode)			In True IDE Mode, all Task File operations occur in byte mode on the low order bus D[7:0] while all data transfers are 16 bit using D[15:0].
GND (PC Card Memory Mode)	-	1,50	Ground.
GND (PC Card I/O Mode)			This signal is the same for all modes.
GND (True IDE Mode)			This signal is the same for all modes.
-INPACK (PC Card Memory Mode)	O	43	This signal is not used in this mode.
-INPACK (PC Card I/O Mode)			The Input Acknowledge signal is asserted by the CompactFlash Storage Card or CF+ Card when the card is selected and responding to an I/O read cycle at the address that is on the address bus. This signal is used by the host to control the enable of any input data buffers between the CompactFlash Storage Card or CF+ Card and the CPU.
DMARQ (True IDE Mode)			<p>This signal is a DMA Request that is used for DMA data transfers between host and device. It shall be asserted by the device when it is ready to transfer data to or from the host. For Multiword DMA transfers, the direction of data transfer is controlled by -IORD and -IOWR. This signal is used in a handshake manner with -DMACK, i.e., the device shall wait until the host asserts -DMACK before negating DMARQ, and re-asserting DMARQ if there is more data to transfer.</p> <p>DMARQ shall not be driven when the device is not selected.</p> <p>While a DMA operation is in progress, -CS0 and -CS1 shall be held negated and the width of the transfers shall be 16 bits.</p> <p>If there is no hardware support for DMA mode in the host, this output signal is not used and should not be connected at the host. In this case, the BIOS must report that DMA mode is not supported by the host so that device drivers will not attempt DMA mode.</p> <p>A host that does not support DMA mode and implements both PCMCIA and True-IDE modes of operation need not alter the PCMCIA mode connections while in True-IDE mode as long as this does not prevent proper operation in any mode.</p>
-IORD (PC Card Memory Mode)	I	34	This signal is not used in this mode.

Transcend Industrial CF Card (128MB ~ 8GB)

Signal Name	Dir.	Pin	Description
-IORD (PC Card I/O Mode)			This is an I/O Read strobe generated by the host. This signal gates I/O data onto the bus from the CompactFlash Storage Card or CF+ Card when the card is configured to use the I/O interface.
-IORD (True IDE Mode – Except Ultra DMA Protocol Active)			In True IDE Mode, while Ultra DMA mode is not active, this signal has the same function as in PC Card I/O Mode.
-HDMARDY (True IDE Mode – In Ultra DMA Protocol DMA Read)			In True IDE Mode when Ultra DMA mode DMA Read is active, this signal is asserted by the host to indicate that the host is read to receive Ultra DMA data-in bursts. The host may negate -HDMARDY to pause an Ultra DMA transfer.
HSTROBE (True IDE Mode – In Ultra DMA Protocol DMA Write)			In True IDE Mode when Ultra DMA mode DMA Write is active, this signal is the data out strobe generated by the host. Both the rising and falling edge of HSTROBE cause data to be latched by the device. The host may stop generating HSTROBE edges to pause an Ultra DMA data-out burst.
-IOWR (PC Card Memory Mode)	I	35	This signal is not used in this mode.
-IOWR (PC Card I/O Mode)			The I/O Write strobe pulse is used to clock I/O data on the Card Data bus into the CompactFlash Storage Card or CF+ Card controller registers when the CompactFlash Storage Card or CF+ Card is configured to use the I/O interface.
-IOWR (True IDE Mode – Except Ultra DMA Protocol Active)			The clocking shall occur on the negative to positive edge of the signal (trailing edge).
-IOWR (True IDE Mode – Except Ultra DMA Protocol Active)			In True IDE Mode, while Ultra DMA mode protocol is not active, this signal has the same function as in PC Card I/O Mode. When Ultra DMA mode protocol is supported, this signal must be negated before entering Ultra DMA mode protocol.
STOP (True IDE Mode – Ultra DMA Protocol Active)			In True IDE Mode, while Ultra DMA mode protocol is active, the assertion of this signal causes the termination of the Ultra DMA burst.
-OE (PC Card Memory Mode)	I	9	This is an Output Enable strobe generated by the host interface. It is used to read data from the CompactFlash Storage Card or CF+ Card in Memory Mode and to read the CIS and configuration registers.
-OE (PC Card I/O Mode)			In PC Card I/O Mode, this signal is used to read the CIS and configuration registers.
-ATA SEL (True IDE Mode)			To enable True IDE Mode this input should be grounded by the host.

Transcend Industrial CF Card (128MB ~ 8GB)

Signal Name	Dir.	Pin	Description
READY (PC Card Memory Mode)	O	37	In Memory Mode, this signal is set high when the CompactFlash Storage Card or CF+ Card is ready to accept a new data transfer operation and is held low when the card is busy. At power up and at Reset, the READY signal is held low (busy) until the CompactFlash Storage Card or CF+ Card has completed its power up or reset function. No access of any type should be made to the CompactFlash Storage Card or CF+ Card during this time. Note, however, that when a card is powered up and used with RESET continuously disconnected or asserted, the Reset function of the RESET pin is disabled. Consequently, the continuous assertion of RESET from the application of power shall not cause the READY signal to remain continuously in the busy state.
-IREQ (PC Card I/O Mode)			I/O Operation – After the CompactFlash Storage Card or CF+ Card has been configured for I/O operation, this signal is used as -Interrupt Request. This line is strobed low to generate a pulse mode interrupt or held low for a level mode interrupt.
INTRQ (True IDE Mode)			In True IDE Mode signal is the active high Interrupt Request to the host.
-REG (PC Card Memory Mode) Attribute Memory Select	I	44	This signal is used during Memory Cycles to distinguish between Common Memory and Register (Attribute) Memory accesses. High for Common Memory, Low for Attribute Memory. The signal shall also be active (low) during I/O Cycles when the I/O address is on the Bus.
-DMACK (True IDE Mode)			This is a DMA Acknowledge signal that is asserted by the host in response to DMARQ to initiate DMA transfers. While DMA operations are not active, the card shall ignore the -DMACK signal, including a floating condition. If DMA operation is not supported by a True IDE Mode only host, this signal should be driven high or connected to VCC by the host. A host that does not support DMA mode and implements both PCMCIA and True-IDE modes of operation need not alter the PCMCIA mode connections while in True-IDE mode as long as this does not prevent proper operation all modes.
RESET (PC Card Memory Mode)	I	41	The CompactFlash Storage Card or CF+ Card is Reset when the RESET pin is high with the following important exception: The host may leave the RESET pin open or keep it continually high from the application of power without causing a continuous Reset of the card. Under either of these conditions, the card shall emerge from power-up having completed an initial Reset. The CompactFlash Storage Card or CF+ Card is also Reset when the Soft Reset bit in the Card Configuration Option Register is set. This signal is the same as the PC Card Memory Mode signal.
RESET (PC Card I/O Mode)			
-RESET (True IDE Mode)			In the True IDE Mode, this input pin is the active low hardware reset from the host.
VCC (PC Card Memory Mode)	–	13,38	+5 V, +3.3 V power.

Transcend Industrial CF Card (128MB ~ 8GB)

Signal Name	Dir.	Pin	Description
VCC (PC Card I/O Mode)			This signal is the same for all modes.
VCC (True IDE Mode)			This signal is the same for all modes.
-VS1 -VS2 (PC Card Memory Mode)	O	33 40	Voltage Sense Signals. -VS1 is grounded on the Card and sensed by the Host so that the CompactFlash Storage Card or CF+ Card CIS can be read at 3.3 volts and -VS2 is reserved by PCMCIA for a secondary voltage and is not connected on the Card.
-VS1 -VS2 (PC Card I/O Mode)			This signal is the same for all modes.
-VS1 -VS2 (True IDE Mode)			This signal is the same for all modes.
-WAIT (PC Card Memory Mode)	O	42	The -WAIT signal is driven low by the CompactFlash Storage Card or CF+ Card to signal the host to delay completion of a memory or I/O cycle that is in progress.
-WAIT (PC Card I/O Mode)			This signal is the same as the PC Card Memory Mode signal.
IORDY (True IDE Mode – Except Ultra DMA Mode)			In True IDE Mode, except in Ultra DMA modes, this output signal may be used as IORDY.
-DDMARDY (True IDE Mode – Ultra DMA Write Mode)			In True IDE Mode, when Ultra DMA mode DMA Write is active, this signal is asserted by the host to indicate that the device is read to receive Ultra DMA data-in bursts. The device may negate -DDMARDY to pause an Ultra DMA transfer.
DSTROBE (True IDE Mode – Ultra DMA Read Mode)			In True IDE Mode, when Ultra DMA mode DMA Write is active, this signal is the data out strobe generated by the device. Both the rising and falling edge of DSTROBE cause data to be latched by the host. The device may stop generating DSTROBE edges to pause an Ultra DMA data-out burst.
-WE (PC Card Memory Mode)	I	36	This is a signal driven by the host and used for strobing memory write data to the registers of the CompactFlash Storage Card or CF+ Card when the card is configured in the memory interface mode. It is also used for writing the configuration registers.
-WE (PC Card I/O Mode)			In PC Card I/O Mode, this signal is used for writing the configuration registers.
-WE (True IDE Mode)			In True IDE Mode, this input signal is not used and should be connected to VCC by the host.
WP (PC Card Memory Mode) Write Protect	O	24	Memory Mode – The CompactFlash Storage Card or CF+ Card does not have a write protect switch. This signal is held low after the completion of the reset initialization sequence.
-IOIS16 (PC Card I/O Mode)			I/O Operation – When the CompactFlash Storage Card or CF+ Card is configured for I/O Operation Pin 24 is used for the -I/O Selected is 16 Bit Port (-IOIS16) function. A Low signal indicates that a 16 bit or odd byte only operation can be performed at the addressed port.
-IOCS16 (True IDE Mode)			In True IDE Mode this output signal is asserted low when this device is expecting a word data transfer cycle.

Transcend Industrial CF Card (128MB ~ 8GB)

Electrical Specification

The following tables indicate all D.C. Characteristics for the CompactFlash Storage Card. Unless otherwise stated, conditions are:

$V_{cc} = 5V \pm 10\%$

$V_{cc} = 3.3V \pm 5\%$

■ Absolute Maximum Conditions

Parameter	Symbol	Conditions
Input Power	V_{cc}	-0.3V min. to 6.5V max.
Voltage on any pin except V_{cc} with respect to GND.	V	-0.5V min. to $V_{cc} + 0.5V$ max.

■ Input Power

Voltage	Maximum Average RMS Current	Measurement Method
$3.3V \pm 5\%$	75 mA (500 mA in Power Level 1)	3.3V at 25°C
$5.0V \pm 10\%$	100 mA (500 mA in Power Level 1)	5.0V at 25°C

■ Input Leakage Current

Type	Parameter	Symbol	Conditions	MIN	TYP	MAX	Units
IxZ	Input Leakage Current	IL	$V_{ih} = V_{cc} / V_{il} = Gnd$	-1		1	μA
IxU	Pull-Up Resistor	RPU1	$V_{cc} = 5.0V$	50k		500k	Ohm
IxD	Pull-Down Resistor	RPD1	$V_{cc} = 5.0V$	50k		500k	Ohm

■ Input Characteristics

Type	Parameter	Symbol	MIN	TYP	MAX	MIN	TYP	MAX	Units
			VCC = 3.3 V			VCC = 5.0 V			
1	Input Voltage CMOS	V_{ih} V_{il}	2.4		0.6	4.0^1		0.8	Volts
2	Input Voltage CMOS	V_{ih} V_{il}	1.5		0.6	2.0		0.8	Volts
3	Input Voltage CMOS Schmitt Trigger	V_{th} V_{tl}		1.8 1.0			2.8 2.0		Volts

Transcend Industrial CF Card (128MB ~ 8GB)

■ Output Drive Type

Type	Output Type	Valid Conditions
OTx	Totempole	Ioh & Iol
OZx	Tri-State N-P Channel	Ioh & Iol
OPx	P-Channel Only	Ioh Only
ONx	N-Channel Only	Iol Only

■ Output Drive Characteristics

Type	Parameter	Symbol	Conditions	MIN	TYP	MAX	Units
1	Output Voltage	Voh	Ioh = -4 mA	Vcc -0.8V		Gnd +0.4V	Volts
		Vol	Iol = 4 mA				
2	Output Voltage	Voh	Ioh = -4 mA	Vcc -0.8V		Gnd +0.4V	Volts
		Vol	Iol = 4 mA				
3	Output Voltage	Voh	Ioh = -4 mA	Vcc -0.8V		Gnd +0.4V	Volts
		Vol	Iol = 4 mA				
X	Tri-State Leakage Current	Ioz	Vol = Gnd Voh = Vcc	-10		10	μA

Transcend Industrial CF Card (128MB ~ 8GB)

■ Signal Interface

Item	Signal	Card ¹⁰	Host ¹⁰
Control Signal	-CE1 -CE2 -REG -IORD -IOWR	Pull-up to Vcc 500 K Ω \geq R \geq 50 K Ω and shall be sufficient to keep inputs inactive when the pins are not connected at the host. ¹	
	-OE -WE	Pull-up to Vcc 500 K Ω \geq R \geq 50 K Ω . ^{1,2}	
	RESET	Pull-up to Vcc 500 K Ω \geq R \geq 50 K Ω . ^{1, 2,9}	
Status Signal	READY -WAIT WP		Pull-up to Vcc R \geq 10 K Ω . ³
	-INPACK		In PCMCIA modes Pull-up to Vcc R \geq 10 K Ω . ⁴ In True IDE mode, if DMA operation is supported by the host, Pull-down to Gnd R \geq 5.6 K Ω . ⁵ PCMCIA / True IDE hosts switch the pull-up to pull-down in True IDE mode if DMA operation is supported. The PCMCIA mode Pull-up may be left active during True IDE mode if True IDE DMA operation is not supported.
Address	A[10:0] -CSEL		
Data Bus	D[15:0]		^{1,}
Card Detect	-CD[2:1]	Connected to GND in the card	
Voltage Sense	-VS1 -VS2		Pull-up to Vcc 10 K Ω \leq R \leq 100K Ω .
Battery/Detect	BVD[2:1]		Pull-up R \geq 50 K Ω . ^{3,6}

Transcend Industrial CF Card (128MB ~ 8GB)

- Notes:
- 1) Control Signals: each card shall present a load to the socket no larger than 50 pF₁₀ at a DC current of 700 μ A low state and 150 μ A high state, including pull-resistor. The socket shall be able to drive at least the following load₁₀ while meeting all AC timing requirements: (the number of sockets wired in parallel) multiplied by (50 pF with DC current 700 μ A low state and 150 μ A high state per socket).
 - 2) Resistor is optional.
 - 3) Status Signals: the socket shall present a load to the card no larger than 50 pF₁₀ at a DC current of 400 μ A low state and 100 μ A high state, including pull-up resistor. The card shall be able to drive at least the following load₁₀ while meeting all AC timing requirements: 50 pF at a DC current of 400 μ A low state and 100 μ A high state.
 - 4) Status Signals: the socket shall present a load to the card no larger than 50 pF₁₀ at a DC current of 400 μ A low state and 100 μ A high state, including pull-up resistor. The card shall be able to drive at least the following load₁₀ while meeting all AC timing requirements: 50 pF at a DC current of 400 μ A low state and 100 μ A high state.
 - 5) Status Signals: the socket shall present a load to the card no larger than 50 pF₁₀ at a DC current of 400 μ A low state and 100 μ A high state, including pull-up resistor. The card shall be able to drive at least the following load₁₀ while meeting all AC timing requirements: 50 pF at a DC current of 400 μ A low state and 1100 μ A high state.
 - 6) BVD2 was not defined in the JEIDA 3.0 release. Systems fully supporting JEIDA release 3 SRAM cards shall pull-up pin 45 (BVD2) to avoid sensing their batteries as "Low."
 - 7) Address Signals: each card shall present a load of no more than 100pF₁₀ at a DC current of 450 μ A low state and 150 μ A high state. The host shall be able to drive at least the following load₁₀ while meeting all AC timing requirements: (the number of sockets wired in parallel) multiplied by (100pF with DC current 450 μ A low state and 150 μ A high state per socket).
 - 8) Data Signals: the host and each card shall present a load no larger than 50pF₁₀ at a DC current of 450 μ A and 150 μ A high state. The host and each card shall be able to drive at least the following load₁₀ while meeting all AC timing requirements: 100pF with DC current 1.6mA low state and 300 μ A high state. This permits the host to wire two sockets in parallel without derating the card access speeds.
 - 9) Reset Signal: This signal is pulled up to prevent the input from floating when a CFA to PCMCIA adapter is used in a PCMCIA revision 1 host. However, to minimize DC current drain through the pull-up resistor in normal operation the pull-up should be turned off once the Reset signal has been actively driven low by the host. Consequently, the input is specified as an I2Z because the resistor is not necessarily detectable in the input current leakage test.
 - 10) Host and card restrictions for CF Advanced Timing Modes and Ultra DMA modes: Additional Requirements for CF Advanced Timing Modes and Ultra DMA Electrical Requirements for additional required limitations on the implementation of CF Advanced Timing modes and Ultra DMA modes respectively.

■ Additional Requirements for CF Advanced Timing Modes

The CF Advanced Timing modes include PCMCIA I/O and Memory modes that are 100ns or faster and True IDE PIO Modes 5,6 and Multiword DMA Modes 3,4.

When operating in CF Advanced timing modes, the host shall conform to the following requirements:

- 1) Only one CF device shall be attached to the CF Bus.
- 2) The host shall not present a load of more than 40pF to the device for all signals, including any cabling.
- 3) The maximum cable length is 0.15 m (6 in). The cable length is measured from the card connector to the host controller. 0.46 m (18 in) cables are not supported.
- 4) The -WAIT and IORDY signals shall be ignored by the host. Devices supporting CF Advanced timing modes shall also support slower timing modes, to ensure operability with systems that do not support CF Advanced timing modes

Transcend Industrial CF Card (128MB ~ 8GB)

■ Ultra DMA Electrical Requirements

➤ Host and Card signal capacitance limits for Ultra DMA operation

The host interface signal capacitance at the host connector shall be a maximum of 25 pF for each signal as measured at 1 MHz. The card interface signal capacitance at the card connector shall be a maximum of 20 pF for each signal as measured at 1 MHz.

➤ Series termination required for Ultra DMA operation

Series termination resistors are required at both the host and the card for operation in any of the Ultra DMA modes. Table 13 describes typical values for series termination at the host and the device.

Signal	Host Termination	Device Termination
-IORD (-HDMARDY, HSTROBE)	22 ohm	82 ohm
-IOWR (STOP)	22 ohm	82 ohm
-CS0, -CS1	33 ohm	82 ohm
A00, A01, A02	33 ohm	82 ohm
-DMACK	22 ohm	82 ohm
D15 through D00	33 ohm	33 ohm
DMARQ	82 ohm	22 ohm
INTRQ	82 ohm	22 ohm
IORDY (-DDMARDY, DSTROBE)	82 ohm	22 ohm
-RESET	33 ohm	82 ohm

NOTE – Only those signals requiring termination are listed in this table. If a signal is not listed, series termination is not required for operation in an Ultra DMA mode. shows signals also requiring a pull-up or pull-down resistor at the host. The actual termination values should be selected to compensate for transceiver and trace impedance to match the characteristic cable impedance.

Table: Typical Series Termination for Ultra DMA

Transcend Industrial CF Card (128MB ~ 8GB)

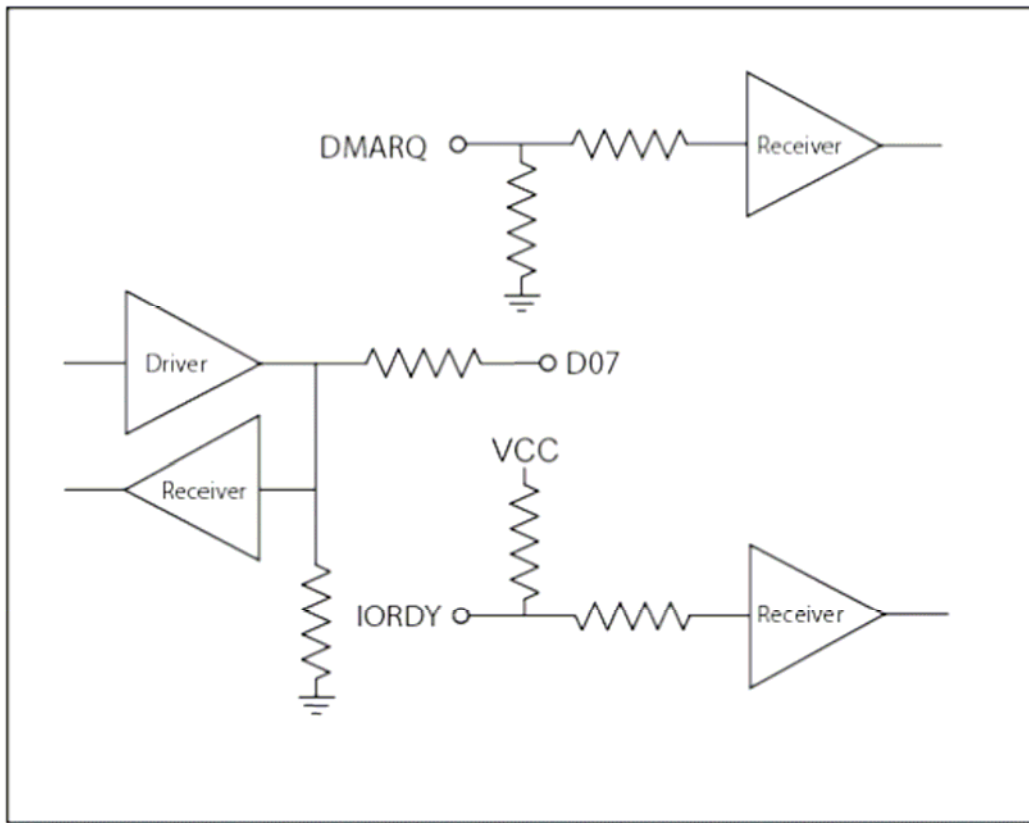

Table: Ultra DMA Termination with Pull-up or Pull down Example

➤ Printed Circuit Board (PCB) Trace Requirements for Ultra DMA

On any PCB for a host or device supporting Ultra DMA:

- ✓ The longest D[15:00] trace shall be no more than 0.5" longer than either STROBE trace as measured from the IC pin to the connector.
- ✓ The shortest D[15:00] trace shall be no more than 0.5" shorter than either STROBE trace as measured from the IC pin to the connector.

➤ Ultra DMA Mode Cabling Requirement

- ✓ Operation in Ultra DMA mode requires a crosstalk suppressing cable. The cable shall have a grounded line between each signal line.
- ✓ For True IDE mode operation using a cable with IDE (ATA) type 40 pin connectors it is recommended that the host sense the cable type using the method described in the ANSI INCITS 361-2002 AT Attachment - 6 standard, to prevent use of Ultra DMA with a 40 conductor cable.

Transcend Industrial CF Card (128MB ~ 8GB)

■ Attribute Memory Read Timing Specification

Speed Version			300 ns	
Item	Symbol	IEEE Symbol	Min ns.	Max ns.
Read Cycle Time	tc(R)	tAVAV	300	
Address Access Time	ta(A)	tAVQV		300
Card Enable Access Time	ta(CE)	tELQV		300
Output Enable Access Time	ta(OE)	tGLQV		150
Output Disable Time from CE	tdis(CE)	tEHQZ		100
Output Disable Time from OE	tdis(OE)	tGHQZ		100
Address Setup Time	tsu(A)	tAVGL	30	
Output Enable Time from CE	ten(CE)	tELQNZ	5	
Output Enable Time from OE	ten(OE)	tGLQNZ	5	
Data Valid from Address Change	tv(A)	tAXQX	0	

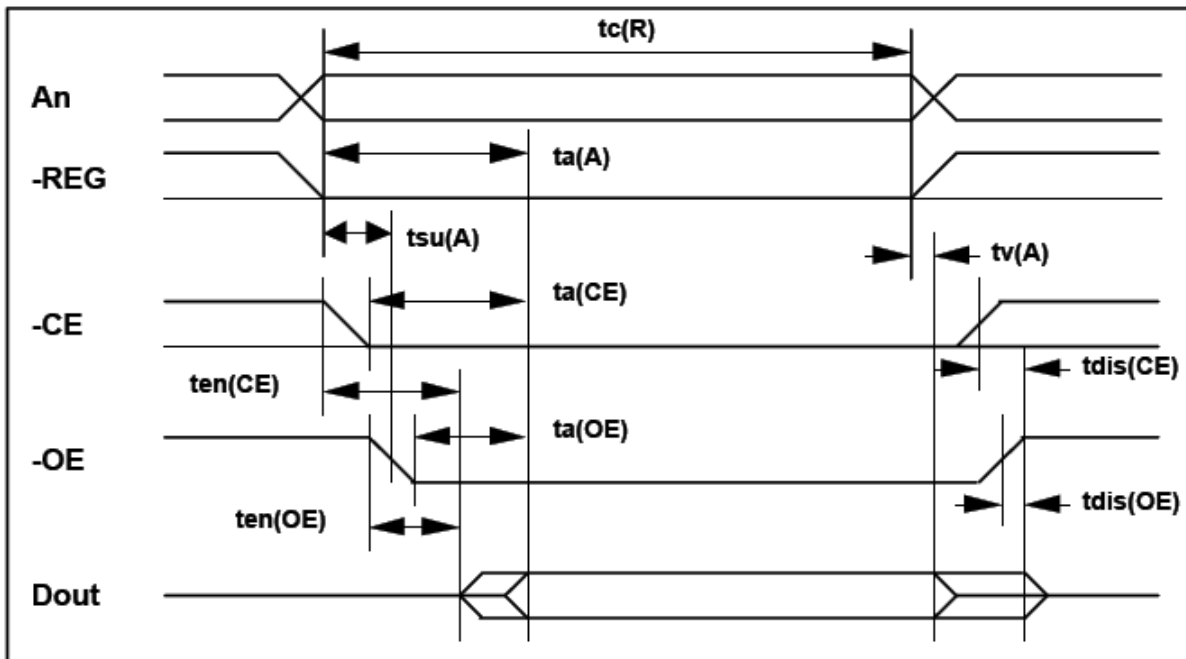

Transcend Industrial CF Card (128MB ~ 8GB)

■ Configuration Register (Attribute Memory) Write Timing Specification

Speed Version			250 ns	
Item	Symbol	IEEE Symbol	Min ns	Max ns
Write Cycle Time	$t_{c(W)}$	t_{AVAV}	250	
Write Pulse Width	$t_{w(WE)}$	t_{WLWH}	150	
Address Setup Time	$t_{su(A)}$	t_{AVWL}	30	
Write Recovery Time	$t_{rec(WE)}$	t_{WMAX}	30	
Data Setup Time for WE	$t_{su(D-WEH)}$	t_{DVWH}	80	
Data Hold Time	$t_{h(D)}$	t_{WMDX}	30	

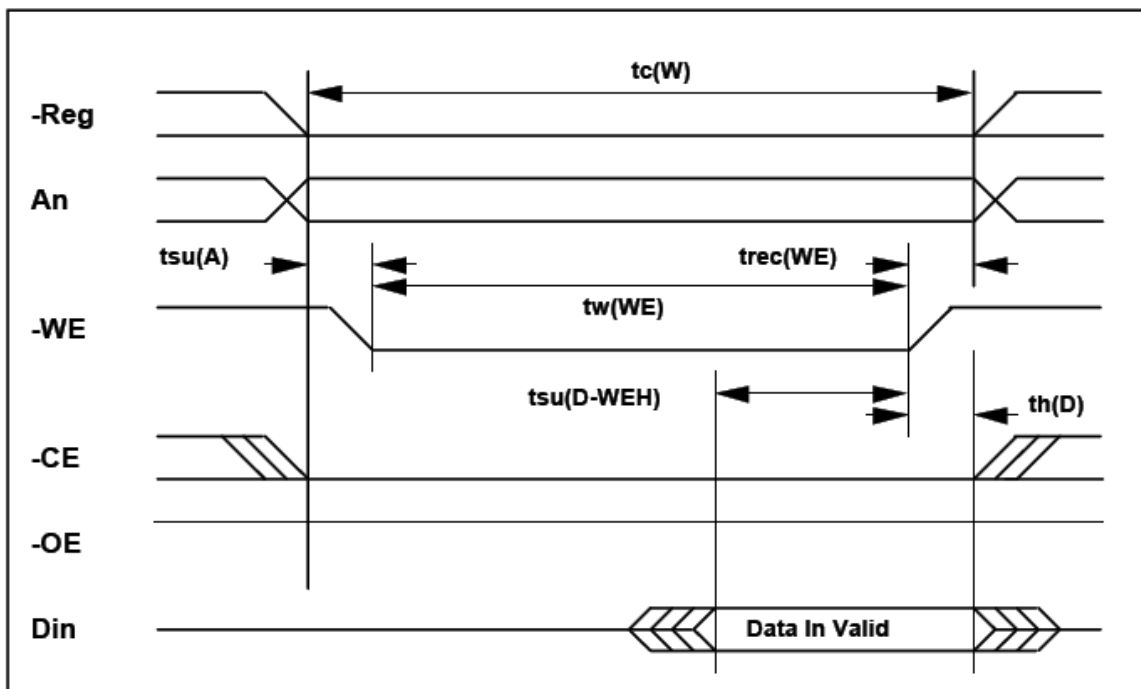

Transcend Industrial CF Card (128MB ~ 8GB)

Common Memory Read Timing Specification

Cycle Time Mode:			250 ns		120 ns		100 ns		80 ns	
Item	Symbol	IEEE Symbol	Min ns.	Max ns.	Min ns.	Max ns.	Min ns.	Max ns.	Min ns.	Max ns.
Output Enable Access Time	ta(OE)	tGLQV		125		60		50		45
Output Disable Time from OE	tdis(OE)	tGHQZ		100		60		50		45
Address Setup Time	tsu(A)	tAVGL	30		15		10		10	
Address Hold Time	th(A)	tGHAX	20		15		15		10	
CE Setup before OE	tsu(CE)	tELGL	0		0		0		0	
CE Hold following OE	th(CE)	tGHEH	20		15		15		10	
Wait Delay Falling from OE	tv(WT-OE)	tGLWTV		35		35		35		na ¹
Data Setup for Wait Release	tv(WT)	tQVWTH		0		0		0		na ¹
Wait Width Time ²	tw(WT)	tWTLWTH		350 (3000 for CF+)		350 (3000 for CF+)		350 (3000 for CF+)		na ¹

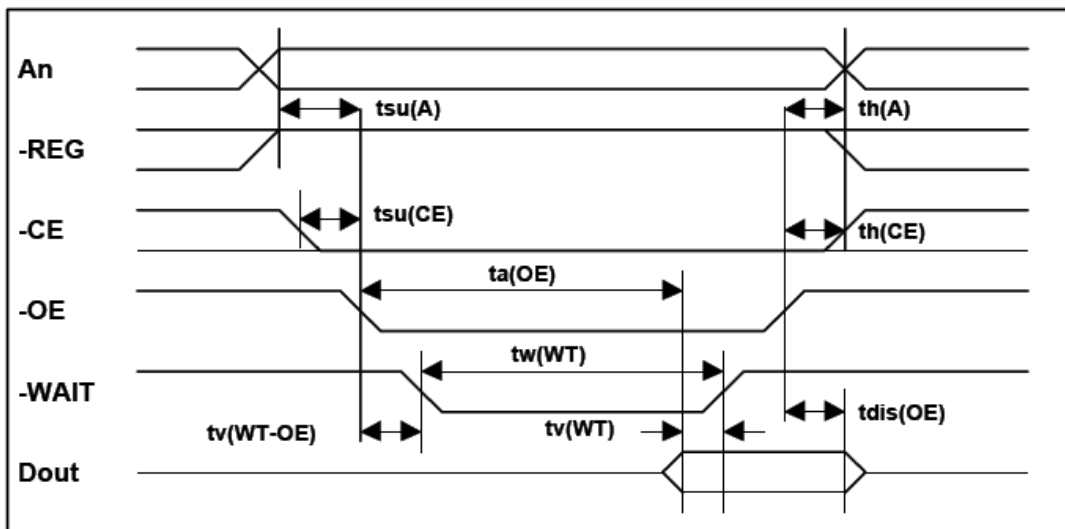

Transcend Industrial CF Card (128MB ~ 8GB)

Common Memory Write Timing Specification

Cycle Time Mode:			250 ns		120 ns		100 ns		80 ns	
Item	Symbol	IEEE Symbol	Min ns.	Max ns.	Min ns.	Max ns.	Min ns.	Max ns.	Min ns.	Max ns.
Data Setup before WE	tsu (D-WEH)	tDVWH	80		50		40		30	
Data Hold following WE	th(D)	tWMDX	30		15		10		10	
WE Pulse Width	tw(WE)	tWLWH	150		70		60		55	
Address Setup Time	tsu(A)	tAVWL	30		15		10		10	
CE Setup before WE	tsu(CE)	tELWL	0		0		0		0	
Write Recovery Time	trec(WE)	tWMAX	30		15		15		15	
Address Hold Time	th(A)	tGHAX	20		15		15		15	
CE Hold following WE	th(CE)	tGHEH	20		15		15		10	
Wait Delay Falling from WE	tv (WT-WE)	tWLWTV		35		35		35		na ¹
WE High from Wait Release	tv(WT)	tWTHWH	0		0		0		na ¹	
Wait Width Time ²	tw (WT)	tWTLWTH		350 (3000 for CF+)		350 (3000 for CF+)		350 (3000 for CF+)		na ¹

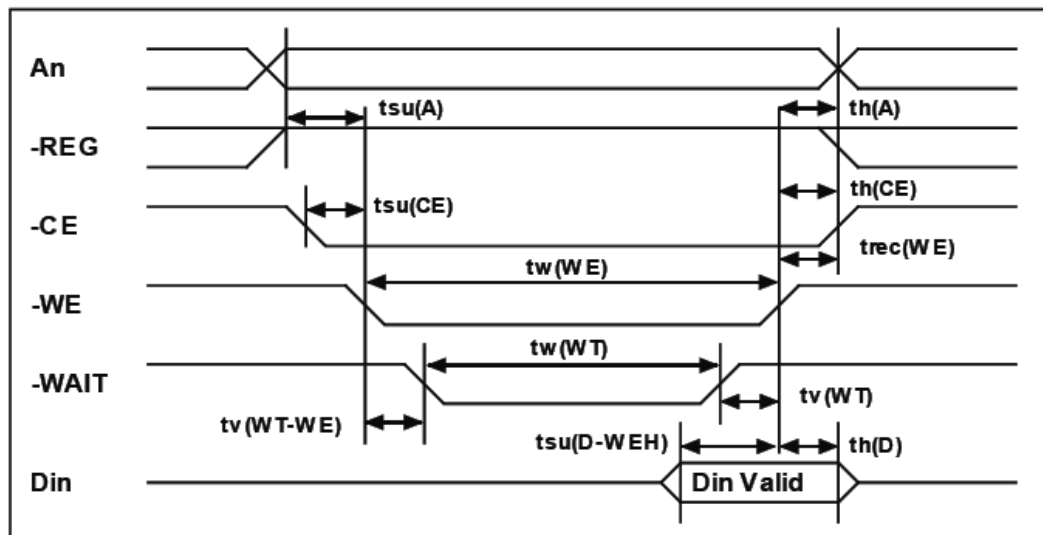

Transcend Industrial CF Card (128MB ~ 8GB)

■ I/O Input (Read) Timing Specification

Item	Symbol	IEEE Symbol	Cycle Time Mode:		250 ns		120 ns		100 ns		80 ns	
			Min ns.	Max ns.	Min ns.	Max ns.	Min ns.	Max ns.	Min ns.	Max ns.		
Data Delay after IORD	td(IORD)	tIGLQV		100		50		50		45		
Data Hold following IORD	th(IORD)	tIGHQX	0		5		5		5			
IORD Width Time	tw(IORD)	tIGLIGH	165		70		65		55			
Address Setup before IORD	tsuA(IORD)	tAVIGL	70		25		25		15			
Address Hold following IORD	thA(IORD)	tIGHAX	20		10		10		10			
CE Setup before IORD	tsuCE(IORD)	tELIGL	5		5		5		5			
CE Hold following IORD	thCE(IORD)	tIGHEH	20		10		10		10			
REG Setup before IORD	tsuREG (IORD)	tRGLIGL	5		5		5		5			
REG Hold following IORD	thREG (IORD)	tIGHRGH	0		0		0		0			
INPACK Delay Falling from IORD ³	tdfINPACK (IORD)	tIGLIAL	0	45	0	na ¹	0	na ¹	0	na ¹		
INPACK Delay Rising from IORD ³	tdrINPACK (IORD)	tIGHIAH		45		na ¹		na ¹		na ¹		
IOIS16 Delay Falling from Address ³	tdfIOIS16 (ADR)	tAVISL		35		na ¹		na ¹		na ¹		
IOIS16 Delay Rising from Address ³	tdrIOIS16 (ADR)	tAVISH		35		na ¹		na ¹		na ¹		
Wait Delay Falling from IORD ³	tdWT(IORD)	tIGLWTL		35		35		35				na ²
Data Delay from Wait Rising ³	td(WT)	tWTHQV		0		0		0				na ²
Wait Width Time ³	tw(WT)	tWTLWTH		350 (3000 for CF+)		350 (3000 for CF+)		350 (3000 for CF+)				na ²

Transcend Industrial CF Card (128MB ~ 8GB)

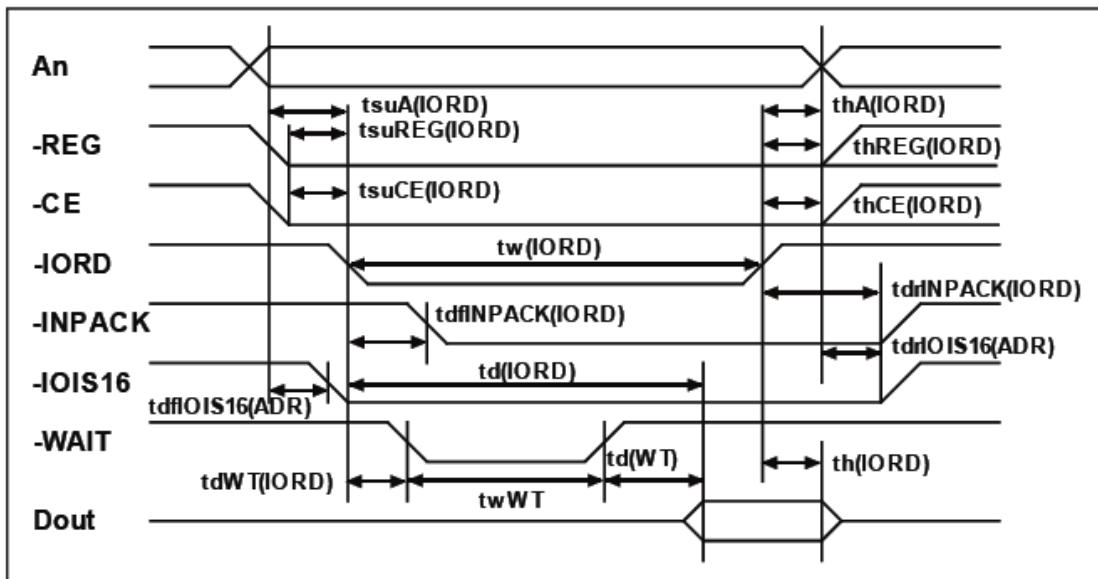

Transcend Industrial CF Card (128MB ~ 8GB)

■ I/O Output (Write) Timing Specification

Item	Symbol	IEEE Symbol	Cycle Time Mode:		255 ns		120 ns		100 ns		80 ns	
			Min ns.	Max ns.	Min ns.	Max ns.	Min ns.	Max ns.	Min ns.	Max ns.		
Data Setup before IOWR	tsu(IOWR)	tDVIWH	60		20		20		15			
Data Hold following IOWR	th(IOWR)	tIWHDX	30		10		5		5			
IOWR Width Time	tw(IOWR)	tIWLWH	165		70		65		55			
Address Setup before IOWR	tsuA(IOWR)	tAVIWL	70		25		25		15			
Address Hold following IOWR	thA(IOWR)	tIWHAX	20		20		10		10			
CE Setup before IOWR	tsuCE (IOWR)	tELIWL	5		5		5		5			
CE Hold following IOWR	thCE (IOWR)	tIWEH	20		20		10		10			
REG Setup before IOWR	tsuREG (IOWR)	tRGLIWL	5		5		5		5			
REG Hold following IOWR	thREG (IOWR)	tIWHRGH	0		0		0		0			
IOIS16 Delay Falling from Address ³	tdfIOIS16 (ADR)	tAVISL		35		na ¹		na ¹		na ¹		
IOIS16 Delay Rising from Address ³	tdrIOIS16 (ADR)	tAVISH		35		na ¹		na ¹		na ¹		
Wait Delay Falling from IOWR ³	tdWT(IOWR)	tIWLWTL		35		35		35		35		na ²
IOWR high from Wait high ³	tdrIOWR (WT)	tWTJIWH	0		0		0		na ²			
Wait Width Time ³	tw(WT)	tWTLWTH		350 (3000 for CF+)		350 (3000 for CF+)		350 (3000 for CF+)		350 (3000 for CF+)		na ²

Transcend Industrial CF Card (128MB ~ 8GB)

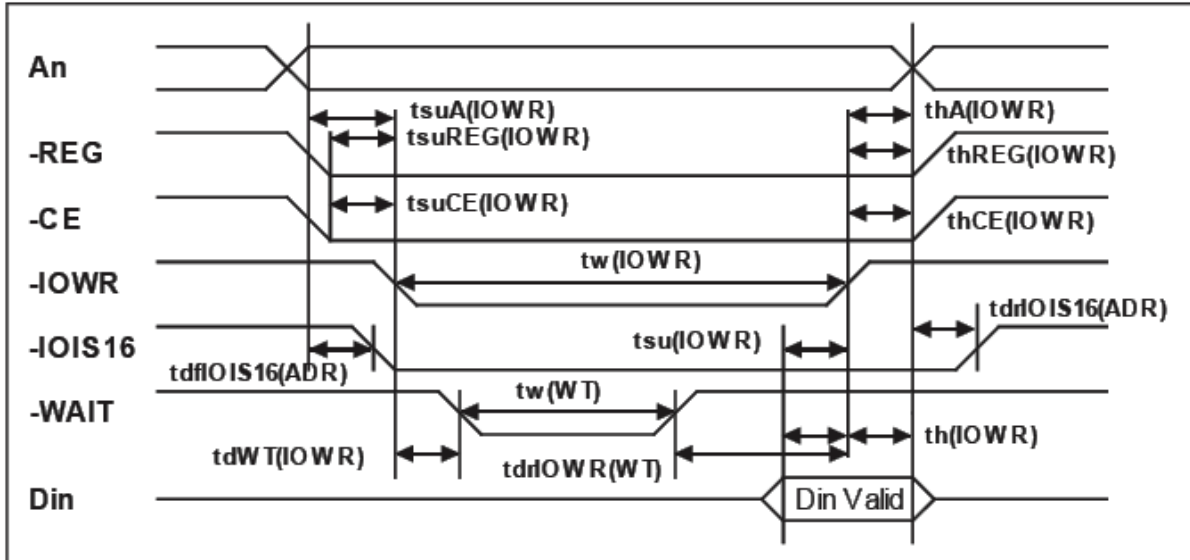

Transcend Industrial CF Card (128MB ~ 8GB)

■ True IDE PIO Mode Read/Write Timing Specification

	Item	Mode 0	Mode 1	Mode 2	Mode 3	Mode 4	Mode 5	Mode 6	Note
t0	Cycle time (min)	600	383	240	180	120	100	80	1
t1	Address Valid to - IORD/-IOWR setup (min)	70	50	30	30	25	15	10	
t2	-IORD/-IOWR (min)	165	125	100	80	70	65	55	1
t2	-IORD/-IOWR (min) Register (8 bit)	290	290	290	80	70	65	55	1
t2i	-IORD/-IOWR recovery time (min)	-	-	-	70	25	25	20	1
t3	-IOWR data setup (min)	60	45	30	30	20	20	15	
t4	-IOWR data hold (min)	30	20	15	10	10	5	5	
t5	-IORD data setup (min)	50	35	20	20	20	15	10	
t6	-IORD data hold (min)	5	5	5	5	5	5	5	
t6Z	-IORD data tristate (max)	30	30	30	30	30	20	20	2
t7	Address valid to - IOCS16 assertion (max)	90	50	40	n/a	n/a	n/a	n/a	4
t8	Address valid to - IOCS16 released (max)	60	45	30	n/a	n/a	n/a	n/a	4
t9	-IORD/-IOWR to address valid hold	20	15	10	10	10	10	10	
tRD	Read Data Valid to IORDY active (min), if IORDY initially low after tA	0	0	0	0	0	0	0	
tA	IORDY Setup time	35	35	35	35	35	na ⁵	na ⁵	3
tB	IORDY Pulse Width (max)	1250	1250	1250	1250	1250	na ⁵	na ⁵	
tC	IORDY assertion to release (max)	5	5	5	5	5	na ⁵	na ⁵	

Transcend Industrial CF Card (128MB ~ 8GB)

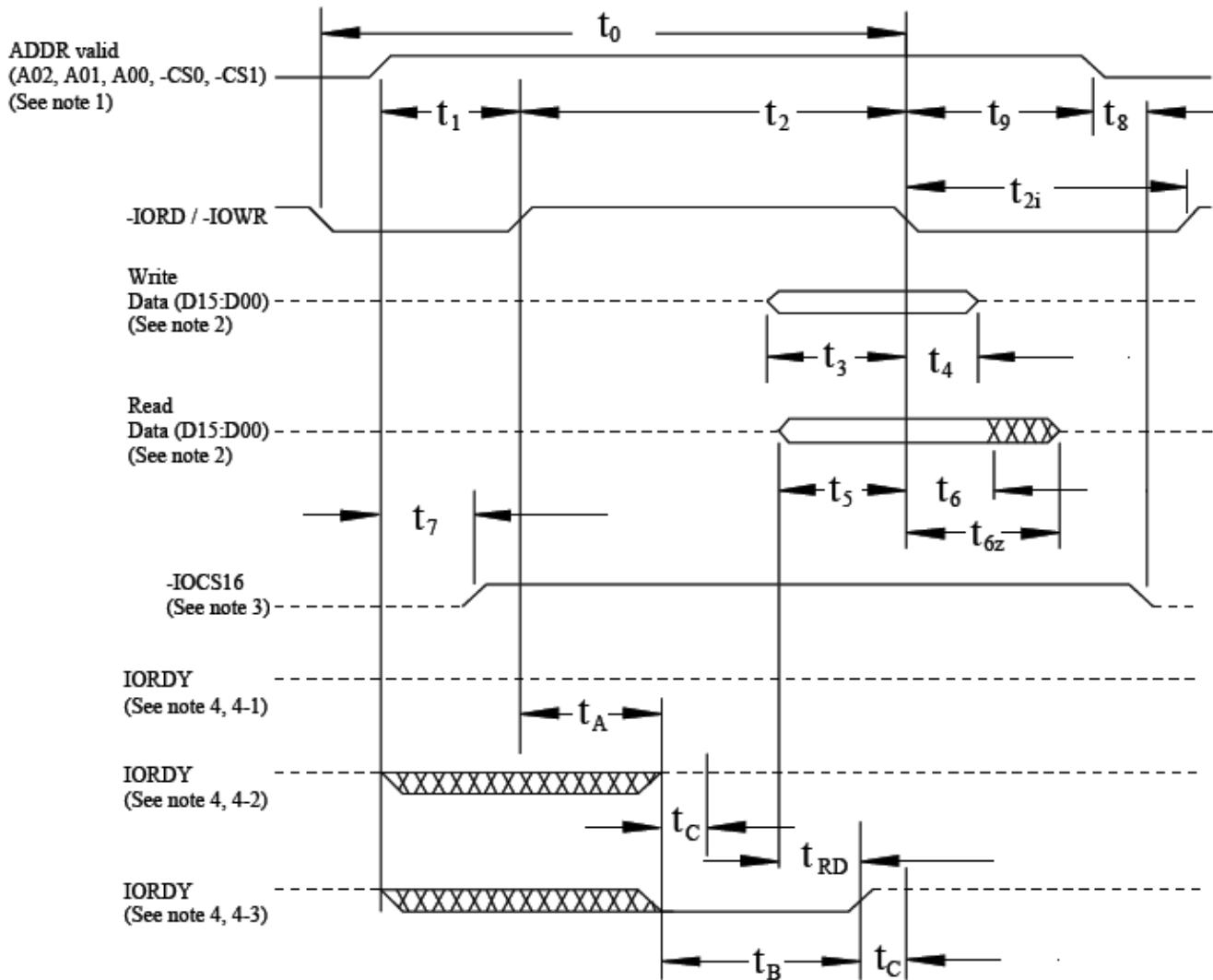

Notes:

- (1) Device address consists of -CS0, -CS1, and A[02::00]
- (2) Data consists of D[15::00] (16-bit) or D[07::00] (8 bit)
- (3) -IOCS16 is shown for PIO modes 0, 1 and 2. For other modes, this signal is ignored.
- (4) The negation of IORDY by the device is used to extend the PIO cycle. The determination of whether the cycle is to be extended is made by the host after t_A from the assertion of -IORD or -IOWR. The assertion and negation of IORDY is described in the following three cases:
 - (4-1) Device never negates IORDY: No wait is generated.
 - (4-2) Device starts to drive IORDY low before t_A , but causes IORDY to be asserted before t_A : No wait generated.
 - (4-3) Device drives IORDY low before t_A : wait generated. The cycle completes after IORDY is reasserted. For cycles where a wait is generated and -IORD is asserted, the device shall place read data on D15-D00 for t_{RD} before causing IORDY to be asserted.

Transcend Industrial CF Card (128MB ~ 8GB)

■ True IDE Ultra DMA Mode Read/Write Timing Specification

Table: Ultra DMA Data Burst Timing

Name	UDMA Mode 0 (ns)		UDMA Mode 1 (ns)		UDMA Mode 2 (ns)		UDMA Mode 3 (ns)		UDMA Mode 4 (ns)		Measurement location (See Note 2)
	Min	Max	Min	Max	Min	Max	Min	Max	Min	Max	
t _{2CYCTYP}	240		160		120		90		60		Sender
t _{2CYC}	112		73		54		39		25		Note 3
t _{2CVC}	230		153		115		86		57		Sender
t _{DS}	15.0		10.0		7.0		7.0		5.0		Recipient
t _{DH}	5.0		5.0		5.0		5.0		5.0		Recipient
t _{DVS}	70.0		48.0		31.0		20.0		6.7		Sender
t _{DVH}	6.2		6.2		6.2		6.2		6.2		Sender
t _{CS}	15.0		10.0		7.0		7.0		5.0		Device
t _{CH}	5.0		5.0		5.0		5.0		5.0		Device
t _{CVS}	70.0		48.0		31.0		20.0		6.7		Host
t _{CVH}	6.2		6.2		6.2		6.2		6.2		Host
t _{ZFS}	0		0		0		0		0		Device
t _{DZFS}	70.0		48.0		31.0		20.0		6.7		Sender
t _{FS}		230		200		170		130		120	Device
t _{LI}	0	150	0	150	0	150	0	100	0	100	Note 4
t _{MLI}	20		20		20		20		20		Host
t _{LI}	0		0		0		0		0		Host
t _{AZ}		10		10		10		10		10	Note 5
t _{ZAH}	20		20		20		20		20		Host
t _{ZAD}	0		0		0		0		0		Device
t _{ENV}	20	70	20	70	20	70	20	55	20	55	Host
t _{RFS}		75		70		60		60		60	Sender
t _{RP}	160		125		100		100		100		Recipient
t _{IORDYZ}		20		20		20		20		20	Device
t _{ZIORDY}	0		0		0		0		0		Device
t _{ACK}	20		20		20		20		20		Host
t _{SS}	50		50		50		50		50		Sender

Transcend Industrial CF Card (128MB ~ 8GB)

- Notes:
- 1) All timing measurement switching points (low to high and high to low) shall be taken at 1.5 V.
 - 2) All signal transitions for a timing parameter shall be measured at the connector specified in the measurement location column. For example, in the case of tRFS, both STROBE and –DMARDY transitions are measured at the sender connector.
 - 3) The parameter tCYC shall be measured at the recipient's connector farthest from the sender.
 - 4)The parameter tLI shall be measured at the connector of the sender or recipient that is responding to an incoming transition from the recipient or sender respectively. Both the incoming signal and the outgoing response shall be measured at the same connector.
 - 5)The parameter tAZ shall be measured at the connector of the sender or recipient that is driving the bus but must release the bus the allow for a bus turnaround.

Transcend Industrial CF Card (128MB ~ 8GB)

Name	Comment	Notes
$t_{2CYCTYP}$	Typical sustained average two cycle time	
t_{CYC}	Cycle time allowing for asymmetry and clock variations (from STROBE edge to STROBE edge)	
t_{2CYC}	Two cycle time allowing for clock variations (from rising edge to next rising edge or from falling edge to next falling edge of STROBE)	
t_{DS}	Data setup time at recipient (from data valid until STROBE edge)	2, 5
t_{DH}	Data hold time at recipient (from STROBE edge until data may become invalid)	2, 5
t_{DVS}	Data valid setup time at sender (from data valid until STROBE edge)	3
t_{DVH}	Data valid hold time at sender (from STROBE edge until data may become invalid)	3
t_{CS}	CRC word setup time at device	2
t_{CH}	CRC word hold time device	2
t_{CVS}	CRC word valid setup time at host (from CRC valid until -DMACK negation)	3
t_{CVH}	CRC word valid hold time at sender (from -DMACK negation until CRC may become invalid)	3
t_{ZFS}	Time from STROBE output released-to-driving until the first transition of critical timing.	
t_{DZFS}	Time from data output released-to-driving until the first transition of critical timing.	
t_{FS}	First STROBE time (for device to first negate DSTROBE from STOP during a data in burst)	
t_{LI}	Limited interlock time	1
t_{MLI}	Interlock time with minimum	1
t_{UI}	Unlimited interlock time	1
t_{AZ}	Maximum time allowed for output drivers to release (from asserted or negated)	
t_{ZAH}	Minimum delay time required for output	
t_{ZAD}	drivers to assert or negate (from released)	
t_{ENV}	Envelope time (from -DMACK to STOP and -DMARDY during data in burst initiation and from DMACK to STOP during data out burst initiation)	
t_{RFS}	Ready-to-final-STROBE time (no STROBE edges shall be sent this long after negation of -DMARDY)	
t_{RP}	Ready-to-pause time (that recipient shall wait to pause after negating -DMARDY)	
t_{IORDYZ}	Maximum time before releasing IORDY	
t_{ZIORDY}	Minimum time before driving IORDY	4
t_{ACK}	Setup and hold times for -DMACK (before assertion or negation)	
t_{SS}	Time from STROBE edge to negation of DMARQ or assertion of STOP (when sender terminates a burst)	

Transcend Industrial CF Card (128MB ~ 8GB)

- Notes: 1) The parameters tUI, tMLI : (Ultra DMA Data-In Burst Device Termination Timing and Ultra DMA Data-In Burst Host Termination Timing), and tLI indicate sender-to-recipient or recipient-to-sender interlocks, i.e., one agent (either sender or recipient) is waiting for the other agent to respond with a signal before proceeding. tUI is an unlimited interlock that has no maximum time value. tMLI is a limited time-out that has a defined minimum. tLI is a limited time-out that has a defined maximum.
- 2) 80-conductor cabling shall be required in order to meet setup (tDS, tCS) and hold (tDH, tCH) times in modes greater than 2.
- 3) Timing for tDVS, tDVH, tCVS and tCVH shall be met for lumped capacitive loads of 15 and 40 pF at the connector where the Data and STROBE signals have the same capacitive load value. Due to reflections on the cable, these timing measurements are not valid in a normally functioning system.
- 4) For all modes the parameter tZIORDY may be greater than tENV due to the fact that the host has a pull-up on IORDY- giving it a known state when released.
- 5) The parameters tDS, and tDH for mode 5 are defined for a recipient at the end of the cable only in a configuration with a single device located at the end of the cable. This could result in the minimum values for tDS and tDH for mode 5 at the middle connector being 3.0 and 3.9 ns respectively.

Name	Comments	UDMA Mode 0 (ns)		UDMA Mode 1 (ns)		UDMA Mode 2 (ns)		UDMA Mode 3 (ns)		UDMA Mode4 (ns)	
		Min	Max	Min	Max	Min	Max	Min	Max	Min	Max
t _{DSIC}	Recipient IC data setup time (from data valid until STROBE edge) (see note 2)	14.7		9.7		6.8		6.8		4.8	
t _{DHIC}	Recipient IC data hold time (from STROBE edge until data may become invalid) (see note 2)	4.8		4.8		4.8		4.8		4.8	
t _{DVSIC}	Sender IC data valid setup time (from data valid until STROBE edge) (see note 3)	72.9		50.9		33.9		22.6		9.5	
t _{DVHIC}	Sender IC data valid hold time (from STROBE edge until data may become invalid) (see note 3)	9.0		9.0		9.0		9.0		9.0	

- Notes: 1) All timing measurement switching points (low to high and high to low) shall be taken at 1.5 V.
- 2) The correct data value shall be captured by the recipient given input data with a slew rate of 0.4 V/ns rising and falling and the input STROBE with a slew rate of 0.4 V/ns rising and falling at t_{DSIC} and t_{DHIC} timing (as measured through 1.5 V).
- 3) The parameters t_{DVSIC} and t_{DVHIC} shall be met for lumped capacitive loads of 15 and 40 pF at the IC where all signals have the same capacitive load value. Noise that may couple onto the output signals from external sources has not been included in these values.

Transcend Industrial CF Card (128MB ~ 8GB)

Name	Comment	Min [V/ns]	Max [V/ns]	Notes
S _{RISE}	Rising Edge Slew Rate for any signal		1.25	1
S _{FALL}	Falling Edge Slew Rate for any signal		1.25	1

Note: 1) The sender shall be tested while driving an 18 inch long, 80 conductor cable with PVC insulation material. The signal under test shall be cut at a test point so that it has not trace, cable or recipient loading after the test point. All other signals should remain connected through to the recipient. The test point may be located at any point between the sender's series termination resistor and one half inch or less of conductor exiting the connector. If the test point is on a cable conductor rather than the PCB, an adjacent ground conductor shall also be cut within one half inch of the connector.

The test load and test points should then be soldered directly to the exposed source side connectors. The test loads consist of a 15 pF or a 40 pF, 5%, 0.08 inch by 0.05 inch surface mount or smaller size capacitor from the test point to ground. Slew rates shall be met for both capacitor values.

Measurements shall be taken at the test point using a <1 pF, >100 Kohm, 1 Ghz or faster probe and a 500 MHz or faster oscilloscope. The average rate shall be measured from 20% to 80% of the settled VOH level with data transitions at least 120 nsec apart. The settled VOH level shall be measured as the average output high level under the defined testing conditions from 100 nsec after 80% of a rising edge until 20% of the subsequent falling edge.

Transcend Industrial CF Card (128MB ~ 8GB)

Card Configuration

The CompactFlash Storage Cards and CF+ Cards are identified by appropriate information in the Card Information Structure (CIS). The following configuration registers are used to coordinate the I/O spaces and the Interrupt level of cards that are located in the system. In addition, these registers provide a method for accessing status information about the CompactFlash Storage Card or CF+ Card that may be used to arbitrate between multiple interrupt sources on the same interrupt level or to replace status information that appears on dedicated pins in memory cards that have alternate use in I/O cards.

■ Single Function CF+ Cards

Single function CF+ Cards shall have a single configuration tuple describing a single set of Function Configuration registers

■ Multiple Function CF+ Cards

Table: CompactFlash Storage Card Registers and Memory Space Decoding

-CE2	-CE1	-REG	-OE	-WE	A10	A9	A8-A4	A3	A2	A1	A0	SELECTED SPACE
1	1	X	X	X	X	X	XX	X	X	X	X	Standby
X	0	0	0	1	0	1	XX	X	X	X	0	Configuration Registers Read
1	0	1	0	1	X	X	XX	X	X	X	X	Common Memory Read (8 Bit D7-D0)
0	1	1	0	1	X	X	XX	X	X	X	X	Common Memory Read (8 Bit D15-D8)
0	0	1	0	1	X	X	XX	X	X	X	0	Common Memory Read (16 Bit D15-D0)
X	0	0	1	0	0	1	XX	X	X	X	0	Configuration Registers Write
1	0	1	1	0	X	X	XX	X	X	X	X	Common Memory Write (8 Bit D7-D0)
0	1	1	1	0	X	X	XX	X	X	X	X	Common Memory Write (8 Bit D15-D8)
0	0	1	1	0	X	X	XX	X	X	X	0	Common Memory Write (16 Bit D15-D0)
X	0	0	0	1	0	0	XX	X	X	X	0	Card Information Structure Read
1	0	0	1	0	0	0	XX	X	X	X	0	Invalid Access (CIS Write)
1	0	0	0	1	X	X	XX	X	X	X	1	Invalid Access (Odd Attribute Read)
1	0	0	1	0	X	X	XX	X	X	X	1	Invalid Access (Odd Attribute Write)
0	1	0	0	1	X	X	XX	X	X	X	X	Invalid Access (Odd Attribute Read)
0	1	0	1	0	X	X	XX	X	X	X	X	Invalid Access (Odd Attribute Write)

Table: CompactFlash Storage Card Configuration Registers Decoding

-CE2	-CE1	-REG	-OE	-WE	A10	A9	A8-A4	A3	A2	A1	A0	SELECTED REGISTER
X	0	0	0	1	0	1	00	0	0	0	0	Configuration Option Reg Read
X	0	0	1	0	0	1	00	0	0	0	0	Configuration Option Reg Write
X	0	0	0	1	0	1	00	0	0	1	0	Card Status Register Read
X	0	0	1	0	0	1	00	0	0	1	0	Card Status Register Write
X	0	0	0	1	0	1	00	0	1	0	0	Pin Replacement Register Read
X	0	0	1	0	0	1	00	0	1	0	0	Pin Replacement Register Write
X	0	0	0	1	0	1	00	0	1	1	0	Socket and Copy Register Read
X	0	0	1	0	0	1	00	0	1	1	0	Socket and Copy Register Write

Transcend Industrial CF Card (128MB ~ 8GB)

Table: CF+ Card Register and Memory Space Decoding

-CE2	-CE1	-REG	-OE	-WE	A10-A1	A0	SELECTED SPACE
1	1	X	X	X	XXX	X	Standby
X	0	0	0	1	XXX	0	Configuration Registers Read
1	0	1	0	1	XXX	X	Common Memory Read (8 Bit D7-D0)
0	1	1	0	1	XXX	X	Common Memory Read (8 Bit D15-D8)
0	0	1	0	1	XXX	0	Common Memory Read (16 Bit D15-D0)
X	0	0	1	0	XXX	0	Configuration Registers Write
1	0	1	1	0	XXX	X	Common Memory Write (8 Bit D7-D0)
0	1	1	1	0	XXX	X	Common Memory Write (8 Bit D15-D8)
0	0	1	1	0	XXX	0	Common Memory Write (16 Bit D15-D0)
X	0	0	0	1	XXX	0	Card Information Structure Read
1	0	0	1	0	XXX	0	Invalid Access (CIS Write)
1	0	0	0	1	XXX	1	Invalid Access (Odd Attribute Read)
1	0	0	1	0	XXX	1	Invalid Access (Odd Attribute Write)
0	1	0	0	1	XXX	X	Invalid Access (Odd Attribute Read)
0	1	0	1	0	XXX	X	Invalid Access (Odd Attribute Write)

Table: CF+ Card Configuration Registers Decoding

-CE2	-CE1	-REG	-OE	-WE	A10 -A5	A4	A3	A2	A1	A0	Selected Register
X	0	0	0	1	XX	0	0	0	0	0	Configuration Option Reg Read
X	0	0	1	0	XX	0	0	0	0	0	Configuration Option Reg Write
X	0	0	0	1	XX	0	0	0	1	0	Card Status Register Read
X	0	0	1	0	XX	0	0	0	1	0	Card Status Register Write
X	0	0	0	1	XX	0	0	1	0	0	Pin Replacement Register Read
X	0	0	1	0	XX	0	0	1	0	0	Pin Replacement Register Write
X	0	0	0	1	XX	0	0	1	1	0	Socket and Copy Register Read
X	0	0	1	0	XX	0	0	1	1	0	Socket and Copy Register Write
X	0	0	0	1	XX	0	1	0	0	0	Reserved
X	0	0	1	0	XX	0	1	0	1	0	I/O Base 0
X	0	0	0	1	XX	0	1	1	0	0	I/O Base 1
X	0	0	1	0	XX	0	1	1	1	0	Reserved
X	0	0	0	1	XX	1	0	0	0	0	Reserved
X	0	0	1	0	XX	1	0	0	1	0	I/O Limit
X	0	0	0	1	XX	1	0	1	0	0	Reserved

Transcend Industrial CF Card (128MB ~ 8GB)

■ Attribute Memory Function

Attribute memory is a space where CompactFlash Storage Card and CF+ Card identification and configuration information are stored, and is limited to 8 bit wide accesses only at even addresses. The card configuration registers are also located here. For CompactFlash Storage Cards, the base address of the card configuration registers is 200h. For CF+ cards, the base address of the card configuration registers is determined by the Configuration tuple (CISTPL_CONFIG).

Table 31: Attribute Memory Function

Function Mode	-REG	-CE2	-CE1	A10	A9	A0	-OE	-WE	D15-D8	D7-D0
Standby Mode	X	H	H	X	X	X	X	X	High Z	High Z
Read Byte Access CIS ROM (8 bits)	L	H	L	L	L	L	L	H	High Z	Even Byte
Write Byte Access CIS (8 bits) (Invalid)	L	H	L	L	L	L	H	L	Don't Care	Even Byte
Read Byte Access Configuration CompactFlash Storage (8 bits)	L	H	L	L	H	L	L	H	High Z	Even Byte
Write Byte Access Configuration CompactFlash Storage (8 bits)	L	H	L	L	H	L	H	L	Don't Care	Even Byte
Read Byte Access Configuration CF+ (8 bits)	L	H	L	X	X	L	L	H	High Z	Even Byte
Write Byte Access Configuration CF+ (8 bits)	L	H	L	X	X	L	H	L	Don't Care	Even Byte
Read Word Access CIS (16 bits)	L	L	L	L	L	X	L	H	Not Valid	Even Byte
Write Word Access CIS (16 bits) (Invalid)	L	L	L	L	L	X	H	L	Don't Care	Even Byte
Read Word Access Configuration CompactFlash Storage (16 bits)	L	L	L	L	H	X	L	H	Not Valid	Even Byte
Write Word Access Configuration CompactFlash Storage (16 bits)	L	L	L	L	H	X	H	L	Don't Care	Even Byte
Read Word Access Configuration CF+ (16 bits)	L	L	L	X	X	X	L	H	Not Valid	Even Byte
Write Word Access Configuration CF+ (16 bits)	L	L	L	X	X	X	H	L	Don't Care	Even Byte

Transcend Industrial CF Card (128MB ~ 8GB)

■ Configuration Option Register (Base + 00h in Attribute Memory)

The Configuration Option Register is used to configure the cards interface, address decoding and interrupt and to issue a soft reset to the CompactFlash Storage Card or CF+ Card.

Operation	D7	D6	D5	D4	D3	D2	D1	D0
R/W	SRESET	LevlREQ	Conf5	Conf4	Conf3	Conf2	Conf1	Conf0

Configuration Option Register

SRESET - Soft Reset: setting this bit to one (1), waiting the minimum reset width time and returning to zero (0) places the CompactFlash Storage Card or CF+ Card in the Reset state. Setting this bit to one (1) is equivalent to assertion of the +RESET signal except that the SRESET bit is not cleared. Returning this bit to zero (0) leaves the CompactFlash Storage Card or CF+ Card in the same un-configured, Reset state as following power-up and hardware reset. This bit is set to zero (0) by power-up and hardware reset. For CompactFlash Storage Cards, using the PCMCIA Soft Reset is considered a hard Reset by the ATA Commands. Contrast with Soft Reset in the Device Control Register.

LevlREQ: this bit is set to one (1) when Level Mode Interrupt is selected, and zero (0) when Pulse Mode is selected. Set to zero (0) by Reset.

Conf5 - Conf0 - Configuration Index: set to zero (0) by reset. It is used to select operation mode of the CompactFlash Storage Card or CF+ Card as shown below.

Note: Conf5 and Conf4 are reserved for CompactFlash Storage cards and shall be written as zero (0). These bits are vendor defined for CF+ Cards.

CompactFlash Storage Card Configurations

Conf5	Conf4	Conf3	Conf2	Conf1	Conf0	Disk Card Mode
0	0	0	0	0	0	Memory Mapped
0	0	0	0	0	1	I/O Mapped, Any 16 byte system decoded boundary
0	0	0	0	1	0	I/O Mapped, 1F0h-1F7h/3F6h-3F7h
0	0	0	0	1	1	I/O Mapped, 170h-177h/376h-377h

CF+ Card Configurations

Conf5	Conf4	Conf3	Conf2	Conf1	Conf0	CF+ Card Mode
0	0	0	0	0	0	Memory Mapped, I/O cycles are ignored
X	X	X	X	X	X	Any non-zero value, vendor defined

Transcend Industrial CF Card (128MB ~ 8GB)

■ Card Configuration and Status Register (Base + 02h in Attribute Memory)

The Card Configuration and Status Register contains information about the Card's condition.

Operation	D7	D6	D5	D4	D3	D2	D1	D0
Read	Changed	SigChg	IOis8	-XE	Audio	PwrDwn	Int	0
Write	0	SigChg	IOis8	-XE	Audio	PwrDwn	0	0

Card Configuration and Status Register

Changed: indicates that one or both of the Pin Replacement register CReady, or CWProt bits are set to one (1). When the Changed bit is set, -STSCHG Pin 46 is held low if the SigChg bit is a One (1) and the CompactFlash Storage Card or CF+ Card is configured for the I/O interface.

SigChg: this bit is set and reset by the host to enable and disable a state-change "signal" from the Status Register, the Changed bit controls pin 46, the Changed Status signal. If no state change signal is desired, this bit is set to zero (0) and pin 46 (-STSCHG) signal is then held high while the CompactFlash Storage Card or CF+ Card is configured for I/O.

IOis8: the host sets this bit to a one (1) if the CompactFlash Storage Card or CF+ Card is to be configured in an 8 bit I/O Mode. The CompactFlash Storage Card is always configured for both 8 and 16 bit I/O, so this bit is ignored. Some CF+ cards can be configured for either 8 bit I/O mode or 16 bit I/O mode, so CF+ cards may respond to this bit.

-XE: this bit is set and reset by the host to disable and enable Power Level 1 commands in CF+ cards. If the value is 0, Power Level 1 commands are enabled; if it is 1, Power Level 1 commands are disabled. Default value at power on or after reset is 0. The host may read the value of this bit to determine whether Power Level 1 commands are currently enabled. For CompactFlash cards that do not support Power Level 1, this bit has value 0 and is not writeable.

Audio: this bit is set and reset by the host to enable and disable audio information on -SPKR when the CF+ card is configured. This bit should always be zero for CompactFlash Storage cards.

PwrDwn: this bit indicates whether the host requests the CompactFlash Storage Card or CF+ Card to be in the power saving or active mode. When the bit is one (1), the CompactFlash Storage Card or CF+ Card enters a power down mode. When PwrDwn is zero (0), the host is requesting the CompactFlash Storage Card or CF+ Card to enter the active mode. The PCMCIA READY value becomes false (busy) when this bit is changed. READY shall not become true (ready) until the power state requested has been entered. The CompactFlash Storage Card automatically powers down when it is idle and powers back up when it receives a command.

Int: this bit represents the internal state of the interrupt request. This value is available whether or not the I/O interface has been configured. This signal remains true until the condition that caused the interrupt request has been serviced. If interrupts are disabled by the -IEN bit in the Device Control Register, this bit is a zero (0).

Transcend Industrial CF Card (128MB ~ 8GB)

■ Pin Replacement Register (Base + 04h in Attribute Memory)

Operation	D7	D6	D5	D4	D3	D2	D1	D0
Read	0	0	CReady	CWProt	1	1	RReady	WProt
Write	0	0	CReady	CWProt	0	0	MReady	MWProt

Pin Replacement Register

CReady: this bit is set to one (1) when the bit RReady changes state. This bit can also be written by the host.

CWProt: this bit is set to one (1) when the RWprot changes state. This bit may also be written by the host.

RReady: this bit is used to determine the internal state of the READY signal. This bit may be used to determine the state of the READY signal as this pin has been reallocated for use as Interrupt Request on an I/O card. When written, this bit acts as a mask (MReady) for writing the corresponding bit CReady.

WProt: this bit is always zero (0) since the CompactFlash Storage Card or CF+ Card does not have a Write Protect switch. When written, this bit acts as a mask for writing the corresponding bit CWProt.

MReady: this bit acts as a mask for writing the corresponding bit CReady.

MWProt: this bit when written acts as a mask for writing the corresponding bit CWProt.

Pin Replacement Changed Bit/Mask Bit Values

Initial Value of (C) Status	Written by Host		Final "C" Bit	Comments
	"C" Bit	"M" Bit		
0	X	0	0	Unchanged
1	X	0	1	Unchanged
X	0	1	0	Cleared by Host
X	1	1	1	Set by Host

Transcend Industrial CF Card (128MB ~ 8GB)

■ Socket and Copy Register (Base + 06h in Attribute Memory)

This register contains additional configuration information. This register is always written by the system before writing the card's Configuration Index Register. This register is not required for CF or CF+ Cards.

If present, it is optional for a CF Card to allow setting bit D4 (Drive number) to 1. If two drives are supported, it is intended for use only when two cards are co-located at either the primary or secondary addresses in PCMCIA I/O mode. The availability and capabilities of this register are described in the Card Information Structure of the CF Card.

Hosts shall not depend on the availability of this functionality.

Operation	D7	D6	D5	D4	D3	D2	D1	D0
Read	Reserved	0	0	Obsolete ¹ (Drive #)	0	0	0	0
Write	0	0	0	Obsolete ¹ (Drive #)	X	X	X	X

Socket and Copy Register

Reserved: this bit is reserved for future standardization. This bit shall be set to zero (0) by the software when the register is written.

Obsolete (Drive #): this bit is obsolete and should be written as 0.

If the obsolete functionality is not supported it shall be read as written or shall be read as 0. If the obsolete functionality is supported, the bit shall be read as written. If supported, this bit sets the drive number, which the card matches with the DRV bit of the Drive/Head register when configured in a twin card configuration.

It is recommended that the host always write 0 for the drive number in this register and in the DRV bit of the Drive/Head register for PCMCIA modes of operation.

X: the socket number is ignored by the CompactFlash Storage Card.

Transcend Industrial CF Card (128MB ~ 8GB)

I/O Transfer Function

The I/O transfer to or from the CompactFlash Storage or CF+ Card can be either 8 or 16 bits. When a 16 bit accessible port is addressed, the signal -IOIS16 is asserted by the CompactFlash Storage or CF+ Card. Otherwise, the -IOIS16 signal is de-asserted. When a 16 bit transfer is attempted, and the -IOIS16 signal is not asserted by the CompactFlash Storage or CF+ Card, the system shall generate a pair of 8 bit references to access the word's even byte and odd byte. The CompactFlash Storage Card permits both 8 and 16 bit accesses to all of its I/O addresses, so -IOIS16 is asserted for all addresses to which the CompactFlash Storage responds. CF+ cards may or may not allow 16 bit register accesses and thus shall assert -IOIS16 as required. The CompactFlash Storage and CF+ Card may request the host to extend the length of an input cycle until data is ready by asserting the -WAIT signal at the start of the cycle.

Table : PCMCIA Mode I/O Function

Function Code	-REG	-CE2	-CE1	A0	-IORD	-IOWR	D15-D8	D7-D0
Standby Mode	X	H	H	X	X	X	High Z	High Z
Byte Input Access (8 bits)	L L	H H	L L	L H	L L	H H	High Z High Z	Even-Byte Odd-Byte
Byte Output Access (8 bits)	L L	H H	L L	L H	H H	L L	Don't Care Don't Care	Even-Byte Odd-Byte
Word Input Access (16 bits)	L	L	L	L	L	H	Odd-Byte	Even-Byte
Word Output Access (16 bits)	L	L	L	L	H	L	Odd-Byte	Even-Byte
I/O Read Inhibit	H	X	X	X	L	H	Don't Care	Don't Care
I/O Write Inhibit	H	X	X	X	H	L	High Z	High Z
High Byte Input Only (8 bits)	L	L	H	X	L	H	Odd-Byte	High Z
High Byte Output Only (8 bits)	L	L	H	X	H	L	Odd-Byte	Don't Care

Transcend Industrial CF Card (128MB ~ 8GB)

Common Memory Transfer Function

The Common Memory transfer to or from the CompactFlash Storage or CF+ Card can be either 8 or 16 bits.

Table: Common Memory Function

Function Code	-REG	-CE2	-CE1	A0	-OE	-WE	D15-D8	D7-D0
Standby Mode	X	H	H	X	X	X	High Z	High Z
Byte Read Access (8 bits)	H H	H H	L L	L H	L L	H H	High Z High Z	Even-Byte Odd-Byte
Byte Write Access (8 bits)	H H	H H	L L	L H	H H	L L	Don't Care Don't Care	Even-Byte Odd-Byte
Word Read Access (16 bits)	H	L	L	X	L	H	Odd-Byte	Even-Byte
Word Write Access (16 bits)	H	L	L	X	H	L	Odd-Byte	Even-Byte
Odd Byte Read Only (8 bits)	H	L	H	X	L	H	Odd-Byte	High Z
Odd Byte Write Only (8 bits)	H	L	H	X	H	L	Odd-Byte	Don't Care

Transcend Industrial CF Card (128MB ~ 8GB)

True IDE Mode I/O Transfer Function

The CompactFlash Storage Card and CF+ Card can be configured in a True IDE Mode of operation. The CompactFlash Storage Card is configured in this mode only when the -OE input signal is grounded by the host during the power off to power on cycle. Optionally, CompactFlash Storage Cards and CF+ Cards may support the following optional detection methods:

1. The card is permitted to monitor the -OE (-ATA SEL) signal at any time(s) and switch to PCMCIA mode upon detecting a high level on the pin.
2. The card is permitted to re-arbitrate the interface mode determination following a transition of the (-)RESET pin.
3. The card is permitted to monitor the -OE (-ATA SEL) signal at any time(s) and switch to True IDE mode upon detection of a continuous low level on pin for an extended period of time.

Table: True IDE Mode I/O Function defines the function of the operations for the True IDE Mode.

Function Code	-CS1	-CS0	A0-A2	-DMACK	-IORD	-IOWR	D15-D8	D7-D0
Invalid Modes	L	L	X	X	X	X	Undefined In/Out	Undefined In/Out
	L	X	X	L	L	X	Undefined Out	Undefined Out
	L	X	X	L	X	L	Undefined In	Undefined In
	X	L	X	L	L	X	Undefined Out	Undefined Out
	X	L	X	L	X	L	Undefined In	Undefined In
Standby Mode	H	H	X	H	X	X	High Z	High Z
Task File Write	H	L	1-7h	H	H	L	Don't Care	Data In
Task File Read	H	L	1-7h	H	L	H	High Z	Data Out
PIO Data Register Write	H	L	0	H	H	L	Odd-Byte In	Even-Byte In
DMA Data Register Write	H	H	X	L	H	L	Odd-Byte In	Even-Byte In
Ultra DMA Data Register Write	H	H	X	L	See Note 2		Odd-Byte In	Even-Byte In
PIO Data Register Read	H	L	0	H	L	H	Odd-Byte Out	Even-Byte Out
DMA Data Register Read	H	H	X	L	L	H	Odd-Byte Out	Even-Byte Out
Ultra DMA Data Register Read	H	H	X	L	See Note 3		Odd-Byte Out	Even-Byte Out
Control Register Write	L	H	6h	H	H	L	Don't Care	Control In
Alt Status Read	L	H	6h	H	L	H	High Z	Status Out
Drive Address ¹	L	H	7h	H	L	H	High Z	Data Out

Transcend Industrial CF Card (128MB ~ 8GB)

Metaformat Overview

The goal of the Metaformat is to describe the requirements and capabilities of the CompactFlash Storage Card and CF+ Card as thoroughly as possible. This includes describing the power requirements, IO requirements, memory requirements, manufacturer information and details about the services provided.

Table: Sample Device Info Tuple Information for Extended Speeds

Speed	Attribute Memory Relative Offset	Code	D7	D6	D5	D4	D3	D2	D1	D0	Notes
250	N+0	D9h	Dh = Function Specific				1	1h = 250 nsec			PCMCIA Std
120	N+0	DFh	Dh = Function Specific				1	7h = Extended			CFA Defined
	N+2	12h	0	2h = 1.2				2h = * 100 nsec			
100	N+0	DCh	Dh = Function Specific				1	4h = 100 nsec			PCMCIA
80	N+0	DFh	Dh = Function Specific				1	7h = Extended			CFA Defined
	N+2	79h	0	Fh = 8.0				1h = * 10 nsec			

Note: The value "1" defined for D3 of the N+0 words indicates that no write-protect switch controls writing the ATA registers. The value "0" defined for D7 in the N+2 words indicates that there is not more than a single speed extension byte.

Transcend Industrial CF Card (128MB ~ 8GB)

CF-ATA Drive Register Set Definition and Protocol

The CompactFlash Storage Card can be configured as a high performance I/O device through:

- a) The standard PC-AT disk I/O address spaces 1F0h-1F7h, 3F6h-3F7h (primary) or 170h- 177h, 376h-377h (secondary) with IRQ 14 (or other available IRQ).
- b) Any system decoded 16 byte I/O block using any available IRQ.
- c) Memory space.

The communication to or from the CompactFlash Storage Card is done using the Task File registers, which provide all the necessary registers for control and status information related to the storage medium. The PCMCIA interface connects peripherals to the host using four register mapping methods. Table 39 is a detailed description of these methods:

Standard Configurations			
Config Index	I/O or Memory	Address	Description
0	Memory	0h-Fh, 400h-7FFh	Memory Mapped
1	I/O	XX0h-XXFh	I/O Mapped 16 Contiguous Registers
2	I/O	1F0h-1F7h, 3F6h-3F7h	Primary I/O Mapped
3	I/O	170h-177h, 376h-377h	Secondary I/O Mapped

Transcend Industrial CF Card (128MB ~ 8GB)

■ I/O Primary and Secondary Address Configurations

Table: Primary and Secondary I/O Decoding

-REG	A9-A4	A3	A2	A1	A0	-IORD=0	-IOWR=0	Note
0	1F(17)h	0	0	0	0	Even RD Data	Even WR Data	1, 2
0	1F(17)h	0	0	0	1	Error Register	Features	1, 2
0	1F(17)h	0	0	1	0	Sector Count	Sector Count	
0	1F(17)h	0	0	1	1	Sector No.	Sector No.	
0	1F(17)h	0	1	0	0	Cylinder Low	Cylinder Low	
0	1F(17)h	0	1	0	1	Cylinder High	Cylinder High	
0	1F(17)h	0	1	1	0	Select Card/Head	Select Card/Head	
0	1F(17)h	0	1	1	1	Status	Command	
0	3F(37)h	0	1	1	0	Alt Status	Device Control	
0	3F(37)h	0	1	1	1	Drive Address	Reserved	

Note: 1) Register 0 is accessed with -CE1 low and -CE2 low (and A0 = Don't Care) as a word register on the combined Odd Data Bus and Even Data Bus (D15-D0). This register may also be accessed by a pair of byte accesses to the offset 0 with -CE1 low and -CE2 high. Note that the address space of this word register overlaps the address space of the Error and Feature byte-wide registers, which lie at offset 1. When accessed twice as byte register with -CE1 low, the first byte to be accessed is the even byte of the word and the second byte accessed is the odd byte of the equivalent word access.

2) A byte access to register 0 with -CE1 high and -CE2 low accesses the error (read) or feature (write) register.

Transcend Industrial CF Card (128MB ~ 8GB)

■ Contiguous I/O Mapped Addressing

When the system decodes a contiguous block of I/O registers to select the CompactFlash Storage Card, the registers are accessed in the block of I/O space decoded by the system as follows:

Table: Contiguous I/O Decoding

-REG	A3	A2	A1	A0	Offset	-IORD=0	-IOWR=0	Notes
0	0	0	0	0	0	Even RD Data	Even WR Data	1
0	0	0	0	1	1	Error	Features	2
0	0	0	1	0	2	Sector Count	Sector Count	
0	0	0	1	1	3	Sector No.	Sector No.	
0	0	1	0	0	4	Cylinder Low	Cylinder Low	
0	0	1	0	1	5	Cylinder High	Cylinder High	
0	0	1	1	0	6	Select Card /Head	Select Card/Head	
0	0	1	1	1	7	Status	Command	
0	1	0	0	0	8	Dup Even RD Data	Dup. Even WR Data	2
0	1	0	0	1	9	Dup. Odd RD Data	Dup. Odd WR Data	2
0	1	1	0	1	D	Dup. Error	Dup. Features	2
0	1	1	1	0	E	Alt Status	Device Ctl	
0	1	1	1	1	F	Drive Address	Reserved	

Transcend Industrial CF Card (128MB ~ 8GB)

■ Memory Mapped Addressing

When the CompactFlash Storage Card registers are accessed via memory references, the registers appear in the common memory space window: 0-2K bytes as follows:

-REG	A10	A9-A4	A3	A2	A1	A0	Offset	-OE=0	-WE=0	Notes
1	0	X	0	0	0	0	0	Even RD Data	Even WR Data	1, 2
1	0	X	0	0	0	1	1	Error	Features	1, 2
1	0	X	0	0	1	0	2	Sector Count	Sector Count	
1	0	X	0	0	1	1	3	Sector No.	Sector No.	
1	0	X	0	1	0	0	4	Cylinder Low	Cylinder Low	
1	0	X	0	1	0	1	5	Cylinder High	Cylinder High	
1	0	X	0	1	1	0	6	Select Card /Head	Select Card/Head	
1	0	X	0	1	1	1	7	Status	Command	
1	0	X	1	0	0	0	8	Dup. Even RD Data	Dup. Even WR Data	2
1	0	X	1	0	0	1	9	Dup. Odd RD Data	Dup. Odd WR Data	2
1	0	X	1	1	0	1	D	Dup. Error	Dup. Features	2
1	0	X	1	1	1	0	E	Alt Status	Device Ctl	
1	0	X	1	1	1	1	F	Drive Address	Reserved	
1	1	X	X	X	X	0	8	Even RD Data	Even WR Data	3
1	1	X	X	X	X	1	9	Odd RD Data	Odd WR Data	3

■ True IDE Mode Addressing

When the CompactFlash Storage Card or CF+ Card is configured in the True IDE Mode, the I/O decoding is as follows:

-CS1	-CS0	A2	A1	A0	-DMACK	-IORD=0	-IOWR=0	Note
1	0	0	0	0	1	PIO RD Data	PIO WR Data	8 or 16 bit ¹
1	1	X	X	X	0	DMA RD Data	DMA WR Data	16 bit
1	0	0	0	1	1	Error Register	Features	8 bit
1	0	0	1	0	1	Sector Count	Sector Count	8 bit
1	0	0	1	1	1	Sector No.	Sector No.	8 bit
1	0	1	0	0	1	Cylinder Low	Cylinder Low	8 bit
1	0	1	0	1	1	Cylinder High	Cylinder High	8 bit
1	0	1	1	0	1	Select Card/Head	Select Card/Head	8 bit
1	0	1	1	1	1	Status	Command	8 bit
0	1	1	1	0	1	Alt Status	Device Control	8 bit

Transcend Industrial CF Card (128MB ~ 8GB)

■ CF-ATA Registers

The following section describes the hardware registers used by the host software to issue commands to the CompactFlash device. These registers are often collectively referred to as the “task file.”

➤ Data Register (Address - 1F0h[170h]; Offset 0,8,9)

The Data Register is a 16 bit register, and it is used to transfer data blocks between the CompactFlash Storage Card data buffer and the Host. This register overlaps the Error Register.

Data Register Memory and I/O Modes	-CE2	-CE1	A0	-REG	Offset	Data Bus
Word Data Register	0	0	X	- ¹	0,8,9	D15-D0
Even Data Register	1	0	0	- ¹	0,8	D7-D0
Odd Data Register	1	0	1	- ¹	9	D7-D0
Odd Data Register	0	1	X	- ¹	8,9	D15-D8
Error / Feature Register	1	0	1	- ¹	1, Dh	D7-D0
Error / Feature Register	0	1	X	- ¹	1	D15-D8
Error / Feature Register	0	0	X	- ¹	Dh	D15-D8
Data Register True IDE Mode	-CS1	-CS0	A0	-DMACK	Offset	Data Bus
PIO Word Data Register	1	0	0	1	0	D15-D0
DMA Word Data Register	1	1	X	0	X	D15-D0
PIO Byte Data Register (Selected Using Set Features Command)	1	0	0	1	0	D7-D0

Notes: 1) -REG signal is mode dependent. Signal shall be 0 for I/O mode and 1 for Memory Mode.

Error Register (Address - 1F1h[171h]; Offset 1, 0Dh Read Only)

This register contains additional information about the source of an error when an error is indicated in bit 0 of the Status register.

D7	D6	D5	D4	D3	D2	D1	D0
BBK/ICRC	UNC	0	IDNF	0	ABRT	0	AMNF

This register is also accessed in PC Card Modes on data bits D15-D8 during a read operation to offset 0 with -CE2 low and -CE1 high.

Bit 7 (BBK/ICRC): this bit is set when a Bad Block is detected. This bit is also set when an interface CRC error is detected in True IDE Ultra DMA modes of operation.

Bit 6 (UNC): this bit is set when an Uncorrectable Error is encountered.

Bit 5: this bit is 0.

Bit 4 (IDNF): the requested sector ID is in error or cannot be found.

Bit 3: this bit is 0.

Bit 2 (Abort) This bit is set if the command has been aborted because of a CompactFlash Storage Card status condition: (Not Ready, Write Fault, etc.) or when an invalid command has been issued.

Bit 1 This bit is 0.

Bit 0 (AMNF) This bit is set in case of a general error.

Transcend Industrial CF Card (128MB ~ 8GB)

- **Feature Register (Address - 1F1h[171h]; Offset 1, 0Dh Write Only)**
This register provides information regarding features of the CompactFlash Storage Card that the host can utilize. This register is also accessed in PC Card modes on data bits D15-D8 during a write operation to Offset 0 with -CE2 low and -CE1 high.
- **Sector Count Register (Address - 1F2h[172h]; Offset 2)**
This register contains the numbers of sectors of data requested to be transferred on a read or write operation between the host and the CompactFlash Storage Card. If the value in this register is zero, a count of 256 sectors is specified. If the command was successful, this register is zero at command completion. If not successfully completed, the register contains the number of sectors that need to be transferred in order to complete the request.
- **Sector Number (LBA 7-0) Register (Address - 1F3h[173h]; Offset 3)**
This register contains the starting sector number or bits 7-0 of the Logical Block Address (LBA) for any CompactFlash Storage Card data access for the subsequent command.
- **6.1.5.5 Cylinder Low (LBA 15-8) Register (Address - 1F4h[174h]; Offset 4)**
This register contains the low order 8 bits of the starting cylinder address or bits 15-8 of the Logical Block Address.
- **Cylinder High (LBA 23-16) Register (Address - 1F5h[175h]; Offset 5)**
This register contains the high order bits of the starting cylinder address or bits 23-16 of the Logical Block Address.
- **Drive/Head (LBA 27-24) Register (Address 1F6h[176h]; Offset 6)**
The Drive/Head register is used to select the drive and head. It is also used to select LBA addressing instead of cylinder/head/sector addressing.

D7	D6	D5	D4	D3	D2	D1	D0
1	LBA	1	DRV	HS3	HS2	HS1	HS0

Bit 7: this bit is specified as 1 for backward compatibility reasons. It is intended that this bit will become obsolete in a future revision of the specification. This bit is ignored by some controllers in some commands.

Bit 6: LBA is a flag to select either Cylinder/Head/Sector (CHS) or Logical Block Address Mode (LBA). When LBA=0, Cylinder/Head/Sector mode is selected. When LBA=1, Logical Block Address is selected. In Logical Block Mode, the Logical Block Address is interpreted as follows:
 LBA7-LBA0: Sector Number Register D7-D0.
 LBA15-LBA8: Cylinder Low Register D7-D0.
 LBA23-LBA16: Cylinder High Register D7-D0.
 LBA27-LBA24: Drive/Head Register bits HS3-HS0.

Bit 5: this bit is specified as 1 for backward compatibility reasons. It is intended that this bit will become obsolete in a future revisions of the specification. This bit is ignored by some controllers in some commands.

Bit 4 (DRV): DRV is the drive number. When DRV=0, drive (card) 0 is selected. When DRV=1, drive (card) 1 is selected. Setting this bit to 1 is obsolete in PCMCIA modes of operation. If the obsolete functionality is support by a CF Storage Card, the CompactFlash Storage Card is set to be Card 0 or 1 using the copy field (Drive #) of the PCMCIA Socket & Copy configuration register.

Transcend Industrial CF Card (128MB ~ 8GB)

Bit 3 (HS3): when operating in the Cylinder, Head, Sector mode, this is bit 3 of the head number. It is Bit 27 in the Logical Block Address mode.

Bit 2 (HS2): when operating in the Cylinder, Head, Sector mode, this is bit 2 of the head number. It is Bit 26 in the Logical Block Address mode.

Bit 1 (HS1): when operating in the Cylinder, Head, Sector mode, this is bit 1 of the head number. It is Bit 25 in the Logical Block Address mode.

Bit 0 (HS0): when operating in the Cylinder, Head, Sector mode, this is bit 0 of the head number. It is Bit 24 in the Logical Block Address mode.

➤ **Status & Alternate Status Registers (Address 1F7h[177h]&3F6h[376h]; Offsets 7 & Eh)**

These registers return the CompactFlash Storage Card status when read by the host. Reading the Status register does clear a pending interrupt while reading the Auxiliary Status register does not. The status bits are described as follows:

D7	D6	D5	D4	D3	D2	D1	D0
BUSY	RDY	DWF	DSC	DRQ	CORR	0	ERR

Bit 7 (BUSY): the busy bit is set when the CompactFlash Storage Card has access to the command buffer and registers and the host is locked out from accessing the command register and buffer. No other bits in this register are valid when this bit is set to a 1. During the data transfer of DMA commands, the Card shall not assert DMARQ unless either the BUSY bit, the DRQ bit, or both are set to one.

Bit 6 (RDY): RDY indicates whether the device is capable of performing CompactFlash Storage Card operations. This bit is cleared at power up and remains cleared until the CompactFlash Storage Card is ready to accept a command.

Bit 5 (DWF): This bit, if set, indicates a write fault has occurred.

Bit 4 (DSC): This bit is set when the CompactFlash Storage Card is ready.

Bit 3 (DRQ): The Data Request is set when the CompactFlash Storage Card requires that information be transferred either to or from the host through the Data register. During the data transfer of DMA commands, the Card shall not assert DMARQ unless either the BUSY bit, the DRQ bit, or both are set to one.

Bit 2 (CORR): This bit is set when a Correctable data error has been encountered and the data has been corrected. This condition does not terminate a multi-sector read operation.

Bit 1 (IDX): This bit is always set to 0.

Bit 0 (ERR): This bit is set when the previous command has ended in some type of error. The bits in the Error register contain additional information describing the error. It is recommended that media access commands (such as Read Sectors and Write Sectors) that end with an error condition should have the address of the first sector in error in the command block registers.

Transcend Industrial CF Card (128MB ~ 8GB)

➤ **Device Control Register (Address - 3F6h[376h]; Offset Eh)**

This register is used to control the CompactFlash Storage Card interrupt request and to issue an ATA soft reset to the card. This register can be written even if the device is BUSY. The bits are defined as follows:

D7	D6	D5	D4	D3	D2	D1	D0
X(0)	X(0)	X(0)	X(0)	X(0)	SW Rst	-IEn	0

Bit 7: this bit is ignored by the CompactFlash Storage Card. The host software should set this bit to 0.

Bit 6: this bit is ignored by the CompactFlash Storage Card. The host software should set this bit to 0.

Bit 5: this bit is ignored by the CompactFlash Storage Card. The host software should set this bit to 0.

Bit 4: this bit is ignored by the CompactFlash Storage Card. The host software should set this bit to 0.

Bit 3: this bit is ignored by the CompactFlash Storage Card. The host software should set this bit to 0.

Bit 2 (SW Rst): this bit is set to 1 in order to force the CompactFlash Storage Card to perform an AT Disk controller Soft Reset operation. This does not change the PCMCIA Card Configuration Registers as a hardware Reset does. The Card remains in Reset until this bit is reset to '0.'

Bit 1 (-IEn): the Interrupt Enable bit enables interrupts when the bit is 0. When the bit is 1, interrupts from the CompactFlash Storage Card are disabled. This bit also controls the Int bit in the Configuration and Status Register. This bit is set to 0 at power on and Reset.

Bit 0: this bit is ignored by the CompactFlash Storage Card.

Transcend Industrial CF Card (128MB ~ 8GB)

➤ Card (Drive) Address Register (Address 3F7h[377h]; Offset Fh)

This register is provided for compatibility with the AT disk drive interface. It is recommended that this register not be mapped into the host's I/O space because of potential conflicts on Bit 7.

D7	D6	D5	D4	D3	D2	D1	D0
X	-WTG	-HS3	-HS2	-HS1	-HS0	-nDS1	-nDS0

Bit 7: this bit is unknown.

Implementation Note:

Conflicts may occur on the host data bus when this bit is provided by a Floppy Disk Controller operating at the same addresses as the CompactFlash Storage Card. Following are some possible solutions to this problem for the PCMCIA implementation:

- 1) Locate the CompactFlash Storage Card at a non-conflicting address, i.e. Secondary address (377) or in an independently decoded Address Space when a Floppy Disk Controller is located at the Primary addresses.
- 2) Do not install a Floppy and a CompactFlash Storage Card in the system at the same time.
- 3) Implement a socket adapter that can be programmed to (conditionally) tri-state D7 of I/O address 3F7h/377h when a CompactFlash Storage Card is installed and conversely to tristate D6-D0 of I/O address 3F7h/377h when a floppy controller is installed.
- 4) Do not use the CompactFlash Storage Card's Drive Address register. This may be accomplished by either a) If possible, program the host adapter to enable only I/O addresses 1F0h-1F7h, 3F6h (or 170h-177h, 176h) to the CompactFlash Storage Card or b) if provided use an additional Primary / Secondary configuration in the CompactFlash Storage Card which does not respond to accesses to I/O locations 3F7h and 377h. With either of these implementations, the host software shall not attempt to use information in the Drive Address Register.

Bit 6 (-WTG): this bit is 0 when a write operation is in progress; otherwise, it is 1.

Bit 5 (-HS3): this bit is the negation of bit 3 in the Drive/Head register.

Bit 4 (-HS2): this bit is the negation of bit 2 in the Drive/Head register.

Bit 3 (-HS1): this bit is the negation of bit 1 in the Drive/Head register.

Bit 2 (-HS0): this bit is the negation of bit 0 in the Drive/Head register.

Bit 1 (-nDS1): this bit is 0 when drive 1 is active and selected.

Bit 0 (-nDS0): this bit is 0 when the drive 0 is active and selected.

Transcend Industrial CF Card (128MB ~ 8GB)

CF-ATA Command Set

CF-ATA Command Set summarizes the CF-ATA command set with the paragraphs that follow describing the individual commands and the task file for each.

Class	COMMAND	Code	FR	SC	SN	CY	DH	LBA
1	Check Power Mode	E5h or 98h	-	-	-	-	D	-
1	Execute Drive Diagnostic	90h	-	-	-	-	D	-
1	Erase Sector(s)	C0h	-	Y	Y	Y	Y	Y
1	Flush Cache	E7h	-	-	-	-	D	-
2	Format Track	50h	-	Y	-	Y	Y	Y
1	Identify Device	ECh	-	-	-	-	D	-
1	Idle	E3h or 97h	-	Y	-	-	D	-
1	Idle Immediate	E1h or 95h	-	-	-	-	D	-
1	Initialize Drive Parameters	91h	-	Y	-	-	Y	-
1	Key Management Structure Read	B9 Feature 0-127	C	C	C	C	D C	-
1	Key Management Read Keying Material	B9 Feature 80	C	C	C	C	D C	-
2	Key Management Change Key Management Value	B9 Feature 81	C	C	C	C	D C	-
1	NOP	00h	-	-	-	-	D	-
1	Read Buffer	E4h	-	-	-	-	D	-
1	Read DMA	C8h	-	Y	Y	Y	Y	Y
1	Read Long Sector	22h or 23h	-	-	Y	Y	Y	Y
1	Read Multiple	C4h	-	Y	Y	Y	Y	Y
1	Read Sector(s)	20h or 21h	-	Y	Y	Y	Y	Y
1	Read Verify Sector(s)	40h or 41h	-	Y	Y	Y	Y	Y
1	Recalibrate	1Xh	-	-	-	-	D	-
1	Request Sense	03h	-	-	-	-	D	-
1	Security Disable Password	F6h	-	-	-	-	D	-
1	Security Erase Prepare	F3h	-	-	-	-	D	-
1	Security Erase Unit	F4h	-	-	-	-	D	-
1	Security Freeze Lock	F5h	-	-	-	-	D	-
1	Security Set Password	F1h	-	-	-	-	D	-
1	Security Unlock	F2h	-	-	-	-	D	-
1	Seek	7Xh	-	-	Y	Y	Y	Y
1	Set Features	EFh	Y	-	-	-	D	-
1	Set Multiple Mode	C6h	-	Y	-	-	D	-

Transcend Industrial CF Card (128MB ~ 8GB)

Class	COMMAND	Code	FR	SC	SN	CY	DH	LBA
1	Set Sleep Mode	E6h or 99h	-	-	-	-	D	-
1	Standby	E2h or 96h	-	-	-	-	D	-
1	Standby Immediate	E0h or 94h	-	-	-	-	D	-
1	Translate Sector	87h	-	Y	Y	Y	Y	Y
1	Wear Level	F5h	-	-	-	-	Y	-
2	Write Buffer	E8h	-	-	-	-	D	-
2	Write DMA	CAh	-	Y	Y	Y	Y	Y
2	Write Long Sector	32h or 33h	-	-	Y	Y	Y	Y
3	Write Multiple	C5h	-	Y	Y	Y	Y	Y
3	Write Multiple w/o Erase	CDh	-	Y	Y	Y	Y	Y
2	Write Sector(s)	30h or 31h	-	Y	Y	Y	Y	Y
2	Write Sector(s) w/o Erase	38h	-	Y	Y	Y	Y	Y
3	Write Verify	3Ch	-	Y	Y	Y	Y	Y

Definitions:

FR = Features Register

SC = Sector Count Register

SN = Sector Number Register

CY = Cylinder Registers

DH = Card/Drive/Head Register

LBA = Logical Block Address Mode Supported (see command descriptions for use).

Y - The register contains a valid parameter for this command. For the Drive/Head Register Y means both the CompactFlash Storage Card and head parameters are used; D - only the CompactFlash Storage Card parameter is valid and not the head parameter; C - The register contains command specific data (see command descriptions for use).

■ Check Power Mode - 98h or E5h

If the CompactFlash Storage Card is in, going to, or recovering from the sleep mode, the CompactFlash Storage Card sets BSY, sets the Sector Count Register to 00h, clears BSY and generates an interrupt.

If the CompactFlash Storage Card is in Idle mode, the CompactFlash Storage Card sets BSY, sets the Sector Count Register to FFh, clears BSY and generates an interrupt.

Bit ->	7	6	5	4	3	2	1	0
Command (7)	98h or E5h							
C/D/H (6)	X		Drive		X			
Cyl High (5)					X			
Cyl Low (4)					X			
Sec Num (3)					X			
Sec Cnt (2)					X			
Feature (1)					X			

Transcend Industrial CF Card (128MB ~ 8GB)

■ Execute Drive Diagnostic - 90h

When the diagnostic command is issued in a PCMCIA configuration mode, this command runs only on the CompactFlash Storage Card that is addressed by the Drive/Head register. This is because PCMCIA card interface does not allow for direct inter-drive communication (such as the ATA PDIAG and DASP signals). When the diagnostic command is issued in the True IDE Mode, the Drive bit is ignored and the diagnostic command is executed by both the Master and the Slave with the Master responding with status for both devices.

Bit ->	7	6	5	4	3	2	1	0
Command (7)	90h							
C/D/H (6)	X		Drive		X			
Cyl High (5)					X			
Cyl Low (4)					X			
Sec Num (3)					X			
Sec Cnt (2)					X			
Feature (1)					X			

Diagnostic Codes are returned in the Error Register at the end of the command.

Code	Error Type
01h	No Error Detected
02h	Formatter Device Error
03h	Sector Buffer Error
04h	ECC Circuitry Error
05h	Controlling Microprocessor Error
8Xh	Slave Error in True IDE Mode

■ Erase Sector(s) - C0h

This command is used to pre-erase and condition data sectors in advance of a Write without Erase or Write Multiple without Erase command. There is no data transfer associated with this command but a Write Fault error status can occur.

Bit ->	7	6	5	4	3	2	1	0
Command (7)	C0h							
C/D/H (6)	1	LBA	1	Drive	Head (LBA 27-24)			
Cyl High (5)					Cylinder High (LBA 23-16)			
Cyl Low (4)					Cylinder Low (LBA 15-8)			
Sec Num (3)					Sector Number (LBA 7-0)			
Sec Cnt (2)					Sector Count			
Feature (1)					X			

Transcend Industrial CF Card (128MB ~ 8GB)

■ Flush Cache – E7h

This command causes the card to complete writing data from its cache. The card returns status with RDY=1 and DSC=1 after the data in the write cache buffer is written to the media. If the Compact Flash Storage Card does not support the Flush Cache command, the Compact Flash Storage Card shall return command aborted.

Bit ->	7	6	5	4	3	2	1	0
Command (7)	E7h							
C/D/H (6)	X			Drive	X			
Cyl High (5)					X			
Cyl Low (4)					X			
Sec Num (3)					X			
Sec Cnt (2)					X			
Feature (1)					X			

■ Format Track - 50h

This command writes the desired head and cylinder of the selected drive with a vendor unique data pattern (typically FFh or 00h). To remain host backward compatible, the CompactFlash Storage Card expects a sector buffer of data from the host to follow the command with the same protocol as the Write Sector(s) command although the information in the buffer is not used by the CompactFlash Storage Card. If LBA=1 then the number of sectors to format is taken from the Sec Cnt register (0=256). The use of this command is not recommended.

Bit ->	7	6	5	4	3	2	1	0
Command (7)	50h							
C/D/H (6)	1	LBA	1	Drive	Head (LBA 27-24)			
Cyl High (5)					Cylinder High (LBA 23-16)			
Cyl Low (4)					Cylinder Low (LBA 15-8)			
Sec Num (3)					X (LBA 7-0)			
Sec Cnt (2)					Count (LBA mode only)			
Feature (1)					X			

Transcend Industrial CF Card (128MB ~ 8GB)

■ Identify Device – Ech

Bit ->	7	6	5	4	3	2	1	0
Command (7)	ECh							
C/D/H (6)	X	X	X	Drive	X			
Cyl High (5)	X							
Cyl Low (4)	X							
Sec Num (3)	X							
Sec Cnt (2)	X							
Feature (1)	X							

The Identify Device command enables the host to receive parameter information from the CompactFlash Storage Card. This command has the same protocol as the Read Sector(s) command. The parameter words in the buffer have the arrangement and meanings defined in Table as below. All reserved bits or words are zero. Hosts should not depend on Obsolete words in Identify Device containing 0. Table 47 specifies each field in the data returned by the Identify Device Command. In Table as below, X indicates a numeric nibble value specific to the card and aaaa indicates an ASCII string specific to the particular drive.

Word Address	Default Value	Total Bytes	Data Field Type Information
0	848Ah	2	General configuration - signature for the CompactFlash Storage Card
	0XXX	2	General configuration – Bit Significant with ATA-4 definitions.
1	XXXXh	2	Default number of cylinders
2	0000h	2	Reserved
3	00XXh	2	Default number of heads
4	0000h	2	Obsolete
5	0000h	2	Obsolete
6	XXXXh	2	Default number of sectors per track
7-8	XXXXh	4	Number of sectors per card (Word 7 = MSW, Word 8 = LSW)
9	XXXXh	2	Obsolete
10-19	aaaa	20	Serial number in ASCII (Right Justified)
20	0000h	2	Obsolete
21	0000h	2	Obsolete
22	0004h	2	Number of ECC bytes passed on Read/Write Long Commands
23-26	aaaa	8	Firmware revision in ASCII. Big Endian Byte Order in Word
27-46	aaaa	40	Model number in ASCII (Left Justified) Big Endian Byte Order in Word
47	XXXXh	2	Maximum number of sectors on Read/Write Multiple command
48	0000h	2	Reserved

Transcend Industrial CF Card (128MB ~ 8GB)

Word Address	Default Value	Total Bytes	Data Field Type Information
49	XX00h	2	Capabilities
50	0000h	2	Reserved
51	0X00h	2	PIO data transfer cycle timing mode
52	0000h	2	Obsolete
53	000Xh	2	Field Validity
54	XXXXh	2	Current numbers of cylinders
55	XXXXh	2	Current numbers of heads
56	XXXXh	2	Current sectors per track
57-58	XXXXh	4	Current capacity in sectors (LBAs)(Word 57 = LSW, Word 58 = MSW)
59	01XXh	2	Multiple sector setting
60-61	XXXXh	4	Total number of sectors addressable in LBA Mode
62	0000h	2	Reserved
63	0X0Xh	2	Multiword DMA transfer. In PCMCIA mode this value shall be 0h
64	00XXh	2	Advanced PIO modes supported
65	XXXXh	2	Minimum Multiword DMA transfer cycle time per word. In PCMCIA mode this value shall be 0h
66	XXXXh	2	Recommended Multiword DMA transfer cycle time. In PCMCIA mode this value shall be 0h
67	XXXXh	2	Minimum PIO transfer cycle time without flow control
68	XXXXh	2	Minimum PIO transfer cycle time with IORDY flow control
69-79	0000h	20	Reserved
80-81	0000h	4	Reserved – CF cards do not return an ATA version
82-84	XXXXh	6	Features/command sets supported
85-87	XXXXh	6	Features/command sets enabled
88	XXXXh	2	Ultra DMA Mode Supported and Selected
89	XXXXh	2	Time required for Security erase unit completion
90	XXXXh	2	Time required for Enhanced security erase unit completion
91	XXXXh	2	Current Advanced power management value
92-127	0000h	72	Reserved
128	XXXXh	2	Security status
129-159	0000h	64	Vendor unique bytes
160	XXXXh	2	Power requirement description
161	0000h	2	Reserved for assignment by the CFA
162	0000h	2	Key management schemes supported
163	XXXXh	2	CF Advanced True IDE Timing Mode Capability and Setting
164	XXXXh	2	CF Advanced PCMCIA I/O and Memory Timing Mode Capability
165-175	0000h	22	Reserved for assignment by the CFA

Transcend Industrial CF Card (128MB ~ 8GB)

Word Address	Default Value	Total Bytes	Data Field Type Information
176-255	0000h	140	Reserved

➤ **Word 0: General Configuration**

This field indicates the general characteristics of the device. When Word 0 of the Identify drive information is 848Ah then the device is a CompactFlash Storage Card and complies with the CFA specification and CFA command set. It is recommended that PCMCIA modes of operation report only the 848Ah value as they are always intended as removable devices.

Bits 15-0: CF Standard Configuration Value
Word 0 is 848Ah. This is the recommended value of Word 0.

Some operating systems require Bit 6 of Word 0 to be set to 1 (Non-removable device) to use the card as the root storage device. The Card must be the root storage device when a host completely replaces conventional disk storage with a CompactFlash Card in True IDE mode. To support this requirement and provide capability for any future removable media Cards, alternate handling of Word 0 is permitted.

Bits 15-0: CF Preferred Alternate Configuration Values

044Ah: This is the alternate value of Word 0 turns on ATA device and turns off Removable Media and Removable Device while preserving all Retired bits in the word.

0040h: This is the alternate value of Word 0 turns on ATA device and turns off Removable Media and Removable Device while zeroing all Retired bits in the word

Bit 15-12: Configuration Flag

If bits 15:12 are set to 8h then Word 0 shall be 848Ah.

If bits 15:12 are set to 0h then Bits 11:0 are set using the definitions below and the Card is required to support for the CFA command set and report that in bit 2 of Word 83.

Bit 15:12 values other than 8h and 0h are prohibited.

Bits 11-8: Retired

These bits have retired ATA bit definitions. It is recommended that the value of these bits be either the preferred value of 0h or the value of 4h that preserves the corresponding bits from the 848Ah CF signature value.

Bit 7: Removable Media Device

If Bit 7 is set to 1, the Card contains media that can be removed during Card operation.

If Bit 7 is set to 0, the Card contains nonremovable media.

Bit 6: Not Removable Controller and/or Device

Alert! This bit will be considered for obsolescence in a future revision of this standard.

If Bit 6 is set to 1, the Card is intended to be nonremovable during operation.

If Bit 6 is set to 0, the Card is intended to be removable during operation.

Bits 5-0: Retired/Reserved

Alert! Bit 2 will be considered for definition in a future revision of this standard and shall be 0 at this time.

Bits 5-1 have retired ATA bit definitions.

Bit 2 shall be 0.

Bit 0 is Reserved and shall be 0.

It is recommended that the value of bits 5-0 be either the preferred value of 00h or the value of 0Ah that preserves the corresponding bits from the 848Ah CF signature value.

Transcend Industrial CF Card (128MB ~ 8GB)

- **Word 1: Default Number of Cylinders**
This field contains the number of translated cylinders in the default translation mode. This value will be the same as the number of cylinders.
- **Word 3: Default Number of Heads**
This field contains the number of translated heads in the default translation mode.
- **Word 6: Default Number of Sectors per Track**
This field contains the number of sectors per track in the default translation mode.
- **Words 7-8: Number of Sectors per Card**
This field contains the number of sectors per CompactFlash Storage Card. This double word value is also the first invalid address in LBA translation mode.
- **Words 10-19: Serial Number**
This field contains the serial number for this CompactFlash Storage Card and is right justified and padded with spaces (20h).
- **Word 22: ECC Count**
This field defines the number of ECC bytes used on each sector in the Read and Write Long commands. This value shall be set to 0004h.
- **Words 23-26: Firmware Revision**
This field contains the revision of the firmware for this product.
- **Words 27-46: Model Number**
This field contains the model number for this product and is left justified and padded with spaces (20h).
- **Word 47: Read/Write Multiple Sector Count**
Bits 15-8 shall be the recommended value of 80h or the permitted value of 00h. Bits 7-0 of this word define the maximum number of sectors per block that the CompactFlash Storage Card supports for Read/Write Multiple commands.
- **Word 49: Capabilities**
 - Bit 13: Standby Timer
If bit 13 is set to 1 then the Standby timer is supported as defined by the IDLE command
If bit 13 is set to 0 then the Standby timer operation is defined by the vendor.
 - Bit 11: IORDY Supported
If bit 11 is set to 1 then this CompactFlash Storage Card supports IORDY operation.
If bit 11 is set to 0 then this CompactFlash Storage Card may support IORDY operation.
 - Bit 10: IORDY may be disabled
Bit 10 shall be set to 0, indicating that IORDY may not be disabled.
 - Bit 9: LBA supported
Bit 9 shall be set to 1, indicating that this CompactFlash Storage Card supports LBA mode addressing.
CF devices shall support LBA addressing.
 - Bit 8: DMA Supported
If bit 8 is set to 1 then Read DMA and Write DMA commands are supported. Bit 8 shall be set to 0. Read/Write DMA commands are not currently permitted on CF cards.
- **PIO Data Transfer Cycle Timing Mode**
The PIO transfer timing for each CompactFlash Storage Card falls into modes that have unique parametric timing specifications. The value returned in Bits 15-8 shall be 00h for mode 0, 01h for mode 1, or 02h for mode 2. Values 03h through FFh are reserved.

Transcend Industrial CF Card (128MB ~ 8GB)

➤ **Translation Parameters Valid**

Bit 0 shall be set to 1 indicating that words 54 to 58 are valid and reflect the current number of cylinders, heads and sectors. If bit 1 of word 53 is set to 1, the values in words 64 through 70 are valid. If this bit is cleared to 0, the values reported in words 64-70 are not valid. Any CompactFlash Storage Card that supports PIO mode 3 or above shall set bit 1 of word 53 to one and support the fields contained in words 64 through 70.

➤ **Current Number of Cylinders, Heads, Sectors/Track**

These fields contains the current number of user addressable Cylinders, Heads, and Sectors/Track in the current translation mode.

➤ **Current Capacity**

This field contains the product of the current cylinders times heads times sectors.

➤ **Multiple Sector Setting**

Bits 15-9 are reserved and shall be set to 0.

Bit 8 shall be set to 1 indicating that the Multiple Sector Setting is valid.

Bits 7-0 are the current setting for the number of sectors that shall be transferred per interrupt on Read/Write Multiple commands.

➤ **Total Sectors Addressable in LBA Mode**

This field contains the total number of user addressable sectors for the CompactFlash Storage Card in LBA mode only.

➤ **Multiword DMA transfer**

Bits 15 through 8 of word 63 of the Identify Device parameter information is defined as the Multiword DMA mode selected field. If this field is supported, bit 1 of word 53 shall be set to one. This field is bit significant. Only one of bits may be set to one in this field by the CompactFlash Storage Card to indicate the multiword DMA mode which is currently selected. Of these bits, bits 15 through 11 are reserved. Bit 8, if set to one, indicates that Multiword DMA mode 0 has been selected. Bit 9, if set to one, indicates that Multiword DMA mode 1 has been selected. Bit 10, if set to one, indicates that Multiword DMA mode 2 has been selected.

Selection of Multiword DMA modes 3 and above are specific to CompactFlash are reported in word 163, Word 163: CF Advanced True IDE Timing Mode Capabilities and Settings.

Bits 7 through 0 of word 63 of the Identify Device parameter information is defined as the Multiword DMA data transfer supported field. If this field is supported, bit 1 of word 53 shall be set to one. This field is bit significant. Any number of bits may be set to one in this field by the CompactFlash Storage Card to indicate the Multiword DMA modes it is capable of supporting.

Of these bits, bits 7 through 2 are reserved. Bit 0, if set to one, indicates that the CompactFlash Storage Card supports Multiword DMA mode 0. Bit 1, if set to one, indicates that the CompactFlash Storage Card supports Multiword DMA modes 1 and 0. Bit 2, if set to one, indicates that the CompactFlash Storage Card supports Multiword DMA modes 2, 1 and 0. Support for Multiword DMA modes 3 and above are specific to CompactFlash are reported in word 163, Word 163: CF Advanced True IDE Timing Mode Capabilities and Settings.

➤ **Word 64: Advanced PIO transfer modes supported**

Bits 7 through 0 of word 64 of the Identify Device parameter information is defined as the advanced PIO data transfer supported field. If this field is supported, bit 1 of word 53 shall be set to one. This field is bit significant. Any number of bits may be set to one in this field by the CompactFlash Storage Card to indicate the advanced PIO modes it is capable of supporting.

Transcend Industrial CF Card (128MB ~ 8GB)

Of these bits, bits 7 through 2 are reserved. Bit 0, if set to one, indicates that the CompactFlash Storage Card supports PIO mode 3. Bit 1, if set to one, indicates that the CompactFlash Storage Card supports PIO mode 4.

Support for PIO modes 5 and above are specific to CompactFlash are reported in word 163.

➤ **Word 65: Minimum Multiword DMA transfer cycle time**

Word 65 of the parameter information of the Identify Device command is defined as the minimum Multiword DMA transfer cycle time. This field defines, in nanoseconds, the minimum cycle time that, if used by the host, the CompactFlash Storage Card guarantees data integrity during the transfer.

If this field is supported, bit 1 of word 53 shall be set to one. The value in word 65 shall not be less than the minimum cycle time for the fastest DMA mode supported by the device. This field shall be supported by all CompactFlash Storage Cards supporting DMA modes 1 and above. If bit 1 of word 53 is set to one, but this field is not supported, the Card shall return a value of zero in this field.

➤ **Recommended Multiword DMA transfer cycle time**

Word 66 of the parameter information of the Identify Device command is defined as the recommended Multiword DMA transfer cycle time. This field defines, in nanoseconds, the cycle time that, if used by the host, may optimize the data transfer from by reducing the probability that the CompactFlash Storage Card will need to negate the DMARQ signal during the transfer of a sector.

If this field is supported, bit 1 of word 53 shall be set to one. The value in word 66 shall not be less than the value in word 65. This field shall be supported by all CompactFlash Storage Cards supporting DMA modes 1 and above. If bit 1 of word 53 is set to one, but this field is not supported, the Card shall return a value of zero in this field.

➤ **Word 67: Minimum PIO transfer cycle time without flow control**

Word 67 of the parameter information of the Identify Device command is defined as the minimum PIO transfer without flow control cycle time. This field defines, in nanoseconds, the minimum cycle time that, if used by the host, the CompactFlash Storage Card guarantees data integrity during the transfer without utilization of flow control. If this field is supported, Bit 1 of word 53 shall be set to one. Any CompactFlash Storage Card that supports PIO mode 3 or above shall support this field, and the value in word 67 shall not be less than the value reported in word 68. If bit 1 of word 53 is set to one because a CompactFlash Storage Card supports a field in words 64-70 other than this field and the CompactFlash Storage Card does not support this field, the CompactFlash Storage Card shall return a value of zero in this field.

➤ **Word 68: Minimum PIO transfer cycle time with IORDY**

Word 68 of the parameter information of the Identify Device command is defined as the minimum PIO transfer with IORDY flow control cycle time. This field defines, in nanoseconds, the minimum cycle time that the CompactFlash Storage Card supports while performing data transfers while utilizing IORDY flow control. If this field is supported, Bit 1 of word 53 shall be set to one. Any CompactFlash Storage Card that supports PIO mode 3 or above shall support this field, and the value in word 68 shall be the fastest defined PIO mode supported by the CompactFlash Storage Card. If bit 1 of word 53 is set to one because a CompactFlash Storage Card supports a field in words 64-70 other than this field and the CompactFlash Storage Card does not support this field, the CompactFlash Storage Card shall return a value of zero in this field.

➤ **Words 82-84: Features/command sets supported**

Words 82, 83, and 84 shall indicate features/command sets supported. The value 0000h or FFFFh was placed in each of these words by CompactFlash Storage Cards prior to ATA-3 and shall be interpreted by the host as meaning that features/command sets supported are not indicated. Bits 1 through 13 of word 83 and bits 0 through 13 of word 84 are reserved. Bit 14 of word 83 and word 84 shall be set to one and bit 15 of word 83 and word 84 shall be cleared to zero to provide indication that the features/command sets supported words are valid. The values in these words should not be depended on by host implementers.

Transcend Industrial CF Card (128MB ~ 8GB)

Bit 0 of word 82 shall be set to zero; the SMART feature set is not supported.
If bit 1 of word 82 is set to one, the Security Mode feature set is supported.
Bit 2 of word 82 shall be set to zero; the Removable Media feature set is not supported.
Bit 3 of word 82 shall be set to one; the Power Management feature set is supported.
Bit 4 of word 82 shall be set to zero; the Packet Command feature set is not supported.
If bit 5 of word 82 is set to one, write cache is supported.
If bit 6 of word 82 is set to one, look-ahead is supported.
Bit 7 of word 82 shall be set to zero; release interrupt is not supported.
Bit 8 of word 82 shall be set to zero; Service interrupt is not supported.
Bit 9 of word 82 shall be set to zero; the Device Reset command is not supported.
Bit 10 of word 82 shall be set to zero; the Host Protected Area feature set is not supported.
Bit 11 of word 82 is obsolete.
Bit 12 of word 82 shall be set to one; the CompactFlash Storage Card supports the Write Buffer command.
Bit 13 of word 82 shall be set to one; the CompactFlash Storage Card supports the Read Buffer command.
Bit 14 of word 82 shall be set to one; the CompactFlash Storage Card supports the NOP command.
Bit 15 of word 82 is obsolete.

Bit 0 of word 83 shall be set to zero; the CompactFlash Storage Card does not support the Download Microcode command.
Bit 1 of word 83 shall be set to zero; the CompactFlash Storage Card does not support the Read DMA Queued and Write DMA Queued commands.
Bit 2 of word 83 shall be set to one; the CompactFlash Storage Card supports the CFA feature set.
If bit 3 of word 83 is set to one, the CompactFlash Storage Card supports the Advanced Power Management feature set.
Bit 4 of word 83 shall be set to zero; the CompactFlash Storage Card does not support the Removable Media Status feature set.

➤ **Words 85-87: Features/command sets enabled**

Words 85, 86, and 87 shall indicate features/command sets enabled. The value 0000h or FFFFh was placed in each of these words by CompactFlash Storage Cards prior to ATA-4 and shall be interpreted by the host as meaning that features/command sets enabled are not indicated. Bits 1 through 15 of word 86 are reserved. Bits 0-13 of word 87 are reserved. Bit 14 of word 87 shall be set to one and bit 15 of word 87 shall be cleared to zero to provide indication that the features/command sets enabled words are valid. The values in these words should not be depended on by host implementers.

Bit 0 of word 85 shall be set to zero; the SMART feature set is not enabled.
If bit 1 of word 85 is set to one, the Security Mode feature set has been enabled via the Security Set Password command.
Bit 2 of word 85 shall be set to zero; the Removable Media feature set is not supported.
Bit 3 of word 85 shall be set to one; the Power Management feature set is supported.
Bit 4 of word 85 shall be set to zero; the Packet Command feature set is not enabled.
If bit 5 of word 85 is set to one, write cache is enabled.
If bit 6 of word 85 is set to one, look-ahead is enabled.
Bit 7 of word 85 shall be set to zero; release interrupt is not enabled.
Bit 8 of word 85 shall be set to zero; Service interrupt is not enabled.
Bit 9 of word 85 shall be set to zero; the Device Reset command is not supported.
Bit 10 of word 85 shall be set to zero; the Host Protected Area feature set is not supported.
Bit 11 of word 85 is obsolete.
Bit 12 of word 85 shall be set to one; the CompactFlash Storage Card supports the Write Buffer command.
Bit 13 of word 85 shall be set to one; the CompactFlash Storage Card supports the Read Buffer

Transcend Industrial CF Card (128MB ~ 8GB)

command.

Bit 14 of word 85 shall be set to one; the CompactFlash Storage Card supports the NOP command.

Bit 15 of word 85 is obsolete.

Bit 0 of word 86 shall be set to zero; the CompactFlash Storage Card does not support the Download Microcode command.

Bit 1 of word 86 shall be set to zero; the CompactFlash Storage Card does not support the Read DMA Queued and Write DMA Queued commands.

If bit 2 of word 86 shall be set to one, the CompactFlash Storage Card supports the CFA feature set.

If bit 3 of word 86 is set to one, the Advanced Power Management feature set has been enabled via the Set Features command.

Bit 4 of word 86 shall be set to zero; the CompactFlash Storage Card does not support the Removable Media Status feature set.

➤ **Word 88: Ultra DMA Modes Supported and Selected**

Word 88 identifies the Ultra DMA transfer modes supported by the device and indicates the mode that is currently selected. Only one DMA mode shall be selected at any given time. If an Ultra DMA mode is selected, then no Multiword DMA mode shall be selected. If a Multiword DMA mode is selected, then no Ultra DMA mode shall be selected. Support of this word is mandatory if Ultra DMA is supported.

Bits 15-13: Reserved

Bit 12: 1 = Ultra DMA mode 4 is selected 0 = Ultra DMA mode 4 is not selected

Bit 11: 1 = Ultra DMA mode 3 is selected 0 = Ultra DMA mode 3 is not selected

Bit 10: 1 = Ultra DMA mode 2 is selected 0 = Ultra DMA mode 2 is not selected

Bit 9: 1 = Ultra DMA mode 1 is selected 0 = Ultra DMA mode 1 is not selected

Bit 8: 1 = Ultra DMA mode 0 is selected 0 = Ultra DMA mode 0 is not selected

Bits 7-5: Reserved

Bit 4: 1 = Ultra DMA mode 4 and below are supported. Bits 0-3 Shall be set to 1.

Bit 3: 1 = Ultra DMA mode 3 and below are supported, Bits 0-2 Shall be set to 1.

Bit 2: 1 = Ultra DMA mode 2 and below are supported. Bits 0-1 Shall be set to 1.

Bit 1: 1 = Ultra DMA mode 1 and below are supported. Bit 0 Shall be set to 1.

Bit 0: 1 = Ultra DMA mode 0 is supported

➤ **Word 89: Time required for Security erase unit completion**

Word 89 specifies the time required for the Security Erase Unit command to complete. This command shall be supported on CompactFlash Storage Cards that support security.

Value	Time
0	Value not specified
1-254	(Value * 2) minutes
255	>508 minutes

➤ **Word 90: Time required for Enhanced security erase unit completion**

Word 90 specifies the time required for the Enhanced Security Erase Unit command to complete.

This command shall be supported on CompactFlash Storage Cards that support security.

Value	Time
0	Value not specified
1-254	(Value * 2) minutes
255	>508 minutes

Transcend Industrial CF Card (128MB ~ 8GB)

- **Word 91: Advanced power management level value**
Bits 7-0 of word 91 contain the current Advanced Power Management level setting.

- **Word 128: Security Status**
 - Bit 8: Security Level
If set to 1, indicates that security mode is enabled and the security level is maximum.
If set to 0 and security mode is enabled, indicates that the security level is high.
 - Bit 5: Enhanced security erase unit feature supported
If set to 1, indicates that the Enhanced security erase unit feature set is supported.
 - Bit 4: Expire
If set to 1, indicates that the security count has expired and Security Unlock and Security Erase Unit are command aborted until a power-on reset or hard reset.
 - Bit 3: Freeze
If set to 1, indicates that the security is Frozen.
 - Bit 2: Lock
If set to 1, indicates that the security is locked.
 - Bit 1: Enable/Disable
If set to 1, indicates that the security is enabled.
If set to 0, indicates that the security is disabled.
 - Bit 0: Capability
If set to 1, indicates that CompactFlash Storage Card supports security mode feature set.
If set to 0, indicates that CompactFlash Storage Card does not support security mode feature set.

- **Word 160: Power Requirement Description**
This word is required for CompactFlash Storage Cards that support power mode 1.
 - Bit 15: VLD
If set to 1, indicates that this word contains a valid power requirement description.
If set to 0, indicates that this word does not contain a power requirement description.
 - Bit 14: RSV
This bit is reserved and shall be 0.
 - Bit 13: -XP
If set to 1, indicates that the CompactFlash Storage Card does not have Power Level 1 commands.
If set to 0, indicates that the CompactFlash Storage Card has Power Level 1 commands
 - Bit 12: -XE
If set to 1, indicates that Power Level 1 commands are disabled.
If set to 0, indicates that Power Level 1 commands are enabled.
 - Bit 0-11: Maximum current
This field contains the CompactFlash Storage Card's maximum current in mA.

- **Word 162: Key Management Schemes Supported**
 - Bit 0: CPRM support
If set to 1, the device supports CPRM Scheme (Content Protection for Recordable Media)
If set to 0, the device does not support CPRM.
 - Bits 1-15 are reserved for future additional Key Management schemes.

- **Word 163: CF Advanced True IDE Timing Mode Capabilities and Settings**
This word describes the capabilities and current settings for CFA defined advanced timing modes using the True IDE interface.
**Notice! The use of True IDE PIO Modes 5 and above or of Multiword DMA Modes 3 and above impose significant restrictions on the implementation of the host:
Additional Requirements for CF Advanced Timing Modes.**
There are four separate fields defined that describe support and selection of Advanced PIO timing modes and Advanced Multiword DMA timing modes. The older modes are reported in words 63 and 64.

Transcend Industrial CF Card (128MB ~ 8GB)

Word 63: Multiword DMA transfer and 6.2.1.6.19: Word 64: Advanced PIO transfer modes supported.

Bits 2-0: Advanced True IDE PIO Mode Support Indicates the maximum True IDE PIO mode supported by the card.

Value	Maximum PIO mode timing supported
0	Specified in word 64
1	PIO Mode 5
2	PIO Mode 6
3-7	Reserved

Bits 5-3: Advanced True IDE Multiword DMA Mode Support Indicates the maximum True IDE Multiword DMA mode supported by the card.

Value	Maximum Multiword DMA timing mode supported
0	Specified in word 63
1	Multiword DMA Mode 3
2	Multiword DMA Mode 4
3-7	Reserved

Bits 8-6: Advanced True IDE PIO Mode Selected Indicates the current True IDE PIO mode selected on the card.

Value	Current PIO timing mode selected
0	Specified in word 64
1	PIO Mode 5
2	PIO Mode 6
3-7	Reserved

Bits 11-9: Advanced True IDE Multiword DMA Mode Selected Indicates the current True IDE Multiword DMA Mode Selected on the card.

Value	Current Multiword DMA timing mode selected
0	Specified in word 63
1	Multiword DMA Mode 3
2	Multiword DMA Mode 4
3-7	Reserved

Bits 15-12 are reserved.

Transcend Industrial CF Card (128MB ~ 8GB)

➤ Word 164: CF Advanced PCMCIA I/O and Memory Timing Modes Capabilities and Settings

This word describes the capabilities and current settings for CFA defined advanced timing modes using the Memory and PCMCIA I/O interface.

Notice! The use of PCMCIA I/O or Memory modes that are 100ns or faster impose significant restrictions on the implementation of the host:

Additional Requirements for CF Advanced Timing Modes.

Bits 2-0: Maximum Advanced PCMCIA I/O Mode Support Indicates the maximum I/O timing mode supported by the card.

Value	Maximum PCMCIA IO timing mode supported
0	255 ns Cycle PCMCIA I/O Mode
1	120 ns Cycle PCMCIA I/O Mode
2	100 ns Cycle PCMCIA I/O Mode
3	80 ns Cycle PCMCIA I/O Mode
4-7	Reserved

Bits 5-3: Maximum Memory timing mode supported
Indicates the Maximum Memory timing mode supported by the card.
Bits 15-6: Reserved.

Value	Maximum Memory timing mode Supported
0	250 ns Cycle Memory Mode
1	120 ns Cycle Memory Mode
2	100 ns Cycle Memory Mode
3	80 ns Cycle Memory Mode
4-7	Reserved

■ Idle - 97h or E3h

This command causes the CompactFlash Storage Card to set BSY, enter the Idle mode, clear BSY and generate an interrupt. If the sector count is non-zero, it is interpreted as a timer count with each count being 5 milliseconds and the automatic power down mode is enabled. If the sector count is zero, the automatic power down mode is disabled. Note that this time base (5 msec) is different from the ATA specification.

Bit ->	7	6	5	4	3	2	1	0
Command (7)	97h or E3h							
C/D/H (6)		X		Drive			X	
Cyl High (5)					X			
Cyl Low (4)					X			
Sec Num (3)					X			
Sec Cnt (2)	Timer Count (5 msec increments)							
Feature (1)					X			

Transcend Industrial CF Card (128MB ~ 8GB)

■ Idle Immediate - 95h or E1h

This command causes the CompactFlash Storage Card to set BSY, enter the Idle mode, clear BSY and generate an interrupt.

Bit ->	7	6	5	4	3	2	1	0
Command (7)	95h or E1h							
C/D/H (6)		X		Drive			X	
Cyl High (5)					X			
Cyl Low (4)					X			
Sec Num (3)					X			
Sec Cnt (2)					X			
Feature (1)					X			

■ Initialize Drive Parameters - 91h

This command enables the host to set the number of sectors per track and the number of heads per cylinder. Only the Sector Count and the Card/Drive/Head registers are used by this command.

Bit ->	7	6	5	4	3	2	1	0
Command (7)	91h							
C/D/H (6)	X	0	X	Drive		Max Head (no. of heads-1)		
Cyl High (5)					X			
Cyl Low (4)					X			
Sec Num (3)					X			
Sec Cnt (2)					Number of Sectors			
Feature (1)					X			

■ NOP - 00h

This command always fails with the CompactFlash Storage Card returning command aborted.

Bit ->	7	6	5	4	3	2	1	0
Command (7)	00h							
C/D/H (6)		X		Drive			X	
Cyl High (5)					X			
Cyl Low (4)					X			
Sec Num (3)					X			
Sec Cnt (2)					X			
Feature (1)					X			

Transcend Industrial CF Card (128MB ~ 8GB)

■ Read Buffer - E4h

The Read Buffer command enables the host to read the current contents of the CompactFlash Storage Card's sector buffer. This command has the same protocol as the Read Sector(s) command.

Bit ->	7	6	5	4	3	2	1	0
Command (7)	E4h							
C/D/H (6)		X		Drive			X	
Cyl High (5)					X			
Cyl Low (4)					X			
Sec Num (3)					X			
Sec Cnt (2)					X			
Feature (1)					X			

■ Read DMA – C8h

Bit ->	7	6	5	4	3	2	1	0
Command (7)	C8h							
C/D/H (6)	1	LBA	1	Drive	Head (LBA 27-24)			
Cyl High (5)	Cylinder High (LBA 23-16)							
Cyl Low (4)	Cylinder Low (LBA 15-8)							
Sec Num (3)	Sector Number (LBA 7-0)							
Sec Cnt (2)	Sector Count							
Feature (1)	X							

■ Read Long Sector - 22h or 23h

Bit ->	7	6	5	4	3	2	1	0
Command (7)	22h or 23h							
C/D/H (6)	1	LBA	1	Drive	Head (LBA 27-24)			
Cyl High (5)	Cylinder High (LBA 23-16)							
Cyl Low (4)	Cylinder Low (LBA 15-8)							
Sec Num (3)	Sector Number (LBA 7-0)							
Sec Cnt (2)	X							
Feature (1)	X							

Transcend Industrial CF Card (128MB ~ 8GB)

■ Read Multiple - C4h

Bit ->	7	6	5	4	3	2	1	0
Command (7)	C4h							
C/D/H (6)	1	LBA	1	Drive	Head (LBA 27-24)			
Cyl High (5)	Cylinder High (LBA 23-16)							
Cyl Low (4)	Cylinder Low (LBA 15-8)							
Sec Num (3)	Sector Number (LBA 7-0)							
Sec Cnt (2)	Sector Count							
Feature (1)	X							

■ Read Sector(s) - 20h or 21h

Bit ->	7	6	5	4	3	2	1	0
Command (7)	20h or 21h							
C/D/H (6)	1	LBA	1	Drive	Head (LBA 27-24)			
Cyl High (5)	Cylinder High (LBA 23-16)							
Cyl Low (4)	Cylinder Low (LBA 15-8)							
Sec Num (3)	Sector Number (LBA 7-0)							
Sec Cnt (2)	Sector Count							
Feature (1)	X							

■ Read Verify Sector(s) - 40h or 41h

Bit ->	7	6	5	4	3	2	1	0
Command (7)	40h or 41h							
C/D/H (6)	1	LBA	1	Drive	Head (LBA 27-24)			
Cyl High (5)	Cylinder High (LBA 23-16)							
Cyl Low (4)	Cylinder Low (LBA 15-8)							
Sec Num (3)	Sector Number (LBA 7-0)							
Sec Cnt (2)	Sector Count							
Feature (1)	X							

Transcend Industrial CF Card (128MB ~ 8GB)

■ Recalibrate - 1Xh

Bit ->	7	6	5	4	3	2	1	0	
Command (7)	1Xh								
C/D/H (6)	1	LBA	1	Drive	X				
Cyl High (5)					X				
Cyl Low (4)					X				
Sec Num (3)					X				
Sec Cnt (2)					X				
Feature (1)					X				

■ Request Sense - 03h

Bit ->	7	6	5	4	3	2	1	0	
Command (7)	03h								
C/D/H (6)	1	X	1	Drive	X				
Cyl High (5)					X				
Cyl Low (4)					X				
Sec Num (3)					X				
Sec Cnt (2)					X				
Feature (1)					X				

The extended error code is returned to the host in the Error Register.

Extended Error Code	Description
00h	No Error Detected
01h	Self Test OK (No Error)
09h	Miscellaneous Error
20h	Invalid Command
21h	Invalid Address (Requested Head or Sector Invalid)
2Fh	Address Overflow (Address Too Large)
35h, 36h	Supply or generated Voltage Out of Tolerance
11h	Uncorrectable ECC Error
18h	Corrected ECC Error
05h, 30-34h, 37h, 3Eh	Self Test or Diagnostic Failed
10h, 14h	ID Not Found
3Ah	Spare Sectors Exhausted
1Fh	Data Transfer Error / Aborted Command
0Ch, 38h, 3Bh, 3Ch, 3Fh	Corrupted Media Format
03h	Write / Erase Failed
22h	Power Level 1 Disabled

Transcend Industrial CF Card (128MB ~ 8GB)

■ Seek - 7Xh

Bit ->	7	6	5	4	3	2	1	0
Command (7)	7Xh							
C/D/H (6)	1	LBA	1	Drive	Head (LBA 27-24)			
Cyl High (5)	Cylinder High (LBA 23-16)							
Cyl Low (4)	Cylinder Low (LBA 15-8)							
Sec Num (3)	X (LBA 7-0)							
Sec Cnt (2)	X							
Feature (1)	X							

■ Set Features – EFh

Bit ->	7	6	5	4	3	2	1	0
Command (7)	EFh							
C/D/H (6)	X		Drive		X			
Cyl High (5)	X							
Cyl Low (4)	X							
Sec Num (3)	X							
Sec Cnt (2)	Config							
Feature (1)	Feature							

Transcend Industrial CF Card (128MB ~ 8GB)

Feature Supported

Feature	Operation
01h	Enable 8 bit data transfers.
02h	Enable Write Cache.
03h	Set transfer mode based on value in Sector Count register.
05h	Enable Advanced Power Management.
09h	Enable Extended Power operations. <i>(Alert: It has been proposed to remove this feature from a future revision of the specification. Please notify the CFA if you have a requirement for this feature.)</i>
0Ah	Enable Power Level 1 commands.
44h	Product specific ECC bytes apply on Read/Write Long commands.
55h	Disable Read Look Ahead.
66h	Disable Power on Reset (POR) establishment of defaults at Soft Reset.
69h	NOP - Accepted for backward compatibility.
81h	Disable 8 bit data transfer.
82h	Disable Write Cache.
85h	Disable Advanced Power Management.
89h	Disable Extended Power operations. <i>(Alert: It has been proposed to remove this feature from a future revision of the specification. Please notify the CFA if you have a requirement for this feature.)</i>
8Ah	Disable Power Level 1 commands.
96h	NOP - Accepted for backward compatibility.
97h	Accepted for backward compatibility. Use of this Feature is not recommended.
9Ah	Set the host current source capability. Allows tradeoff between current drawn and read/write speed.
AAh	Enable Read Look Ahead.
BBh	4 bytes of data apply on Read/Write Long commands.
CCh	Enable Power on Reset (POR) establishment of defaults at Soft Reset.

Features 01h and 81h are used to enable and clear 8 bit data transfer modes in True IDE Mode. If the 01h feature command is issued all data transfers shall occur on the low order D[7:0] data bus and the -IOIS16 signal shall not be asserted for data register accesses. The host shall not enable this feature for DMA transfers.

Features 02h and 82h allow the host to enable or disable write cache in CompactFlash Storage Cards that implement write cache. When the subcommand disable write cache is issued, the CompactFlash Storage Card shall initiate the sequence to flush cache to non-volatile memory before command completion.

Feature 03h allows the host to select the PIO or Multiword DMA transfer mode by specifying a value in the Sector Count register. The upper 5 bits define the type of transfer and the low order 3 bits encode the mode value. One PIO mode shall be selected at all times. For Cards which support DMA, one Multiword DMA mode shall be selected at all times. The host may change the selected modes by the Set Features command.

Transcend Industrial CF Card (128MB ~ 8GB)

■ Set Multiple Mode - C6h

Bit ->	7	6	5	4	3	2	1	0
Command (7)	C6h							
C/D/H (6)	X			Drive	X			
Cyl High (5)	X							
Cyl Low (4)	X							
Sec Num (3)	X							
Sec Cnt (2)	Sector Count							
Feature (1)	X							

■ Set Sleep Mode- 99h or E6h

Bit ->	7	6	5	4	3	2	1	0
Command (7)	99h or E6h							
C/D/H (6)	X			Drive	X			
Cyl High (5)	X							
Cyl Low (4)	X							
Sec Num (3)	X							
Sec Cnt (2)	X							
Feature (1)	X							

■ Standby - 96h or E2h

Bit ->	7	6	5	4	3	2	1	0
Command (7)	96h or E2h							
C/D/H (6)	X			Drive	X			
Cyl High (5)	X							
Cyl Low (4)	X							
Sec Num (3)	X							
Sec Cnt (2)	X							
Feature (1)	X							

Transcend Industrial CF Card (128MB ~ 8GB)

■ Standby Immediate - 94h or E0h

Bit ->	7	6	5	4	3	2	1	0
Command (7)	94h or E0h							
C/D/H (6)		X		Drive			X	
Cyl High (5)					X			
Cyl Low (4)					X			
Sec Num (3)					X			
Sec Cnt (2)					X			
Feature (1)					X			

■ Translate Sector - 87h

Bit ->	7	6	5	4	3	2	1	0
Command (7)	87h							
C/D/H (6)	1	LBA	1	Drive		Head (LBA 27-24)		
Cyl High (5)	Cylinder High (LBA 23-16)							
Cyl Low (4)	Cylinder Low (LBA 15-8)							
Sec Num (3)	Sector Number (LBA 7-0)							
Sec Cnt (2)					X			
Feature (1)					X			

Translate Sector Information

Address	Information
00h-01h	Cylinder MSB (00), Cylinder LSB (01)
02h	Head
03h	Sector
04h-06h	LBA MSB (04) - LSB (06)
07h-12h	Reserved
13h	Erased Flag (FFh) = Erased; 00h = Not Erased
14h - 17h	Reserved
18h-1Ah	Hot Count MSB (18) - LSB (1A) ¹
1Bh-1Fh	Reserved

Transcend Industrial CF Card (128MB ~ 8GB)

■ Wear Level - F5h

Bit ->	7	6	5	4	3	2	1	0
Command (7)	F5h							
C/D/H (6)	X	X	X	Drive	Flag			
Cyl High (5)					X			
Cyl Low (4)					X			
Sec Num (3)					X			
Sec Cnt (2)	Completion Status							
Feature (1)					X			

■ Write Buffer - E8h

Bit ->	7	6	5	4	3	2	1	0
Command (7)	E8h							
C/D/H (6)	X			Drive	X			
Cyl High (5)					X			
Cyl Low (4)					X			
Sec Num (3)					X			
Sec Cnt (2)					X			
Feature (1)					X			

■ Write DMA – CAh

Bit ->	7	6	5	4	3	2	1	0
Command (7)	CAh							
C/D/H (6)	1	LBA	1	Drive	Head (LBA 27-24)			
Cyl High (5)	Cylinder High (LBA 23-16)							
Cyl Low (4)	Cylinder Low (LBA 15-8)							
Sec Num (3)	Sector Number (LBA 7-0)							
Sec Cnt (2)	Sector Count							
Feature (1)	X							

Transcend Industrial CF Card (128MB ~ 8GB)

■ Write Long Sector - 32h or 33h

Bit ->	7	6	5	4	3	2	1	0
Command (7)	32h or 33h							
C/D/H (6)	1	LBA	1	Drive	Head (LBA 27-24)			
Cyl High (5)	Cylinder High (LBA 23-16)							
Cyl Low (4)	Cylinder Low (LBA 15-8)							
Sec Num (3)	Sector Number (LBA 7-0)							
Sec Cnt (2)	X							
Feature (1)	X							

■ Write Multiple Command - C5h

Bit ->	7	6	5	4	3	2	1	0
Command (7)	C5h							
C/D/H (6)	1	LBA	1	Drive	Head			
Cyl High (5)	Cylinder High							
Cyl Low (4)	Cylinder Low							
Sec Num (3)	Sector Number							
Sec Cnt (2)	Sector Count							
Feature (1)	X							

■ Write Multiple without Erase – CDh

Bit ->	7	6	5	4	3	2	1	0
Command (7)	CDh							
C/D/H (6)	X1	LBA	1	Drive	Head			
Cyl High (5)	Cylinder High							
Cyl Low (4)	Cylinder Low							
Sec Num (3)	Sector Number							
Sec Cnt (2)	Sector Count							
Feature (1)	X							

Transcend Industrial CF Card (128MB ~ 8GB)

■ Write Sector(s) - 30h or 31h

Bit ->	7	6	5	4	3	2	1	0
Command (7)	30h or 31h							
C/D/H (6)	1	LBA	1	Drive	Head (LBA 27-24)			
Cyl High (5)	Cylinder High (LBA 23-16)							
Cyl Low (4)	Cylinder Low (LBA 15-8)							
Sec Num (3)	Sector Number (LBA 7-0)							
Sec Cnt (2)	Sector Count							
Feature (1)	X							

■ Write Sector(s) without Erase - 38h

Bit ->	7	6	5	4	3	2	1	0
Command (7)	38h							
C/D/H (6)	1	LBA	1	Drive	Head (LBA 27-24)			
Cyl High (5)	Cylinder High (LBA 23-16)							
Cyl Low (4)	Cylinder Low (LBA 15-8)							
Sec Num (3)	Sector Number (LBA 7-0)							
Sec Cnt (2)	Sector Count							
Feature (1)	X							

■ Write Verify - 3Ch

Bit ->	7	6	5	4	3	2	1	0
Command (7)	3Ch							
C/D/H (6)	1	LBA	1	Drive	Head (LBA 27-24)			
Cyl High (5)	Cylinder High (LBA 23-16)							
Cyl Low (4)	Cylinder Low (LBA 15-8)							
Sec Num (3)	Sector Number (LBA 7-0)							
Sec Cnt (2)	Sector Count							
Feature (1)	X							

Transcend Industrial CF Card (128MB ~ 8GB)

■ Error Posting

Command	Error Register					Status Register				
	BBK	UNC	IDNF	ABRT	AMNF	DRDY	DWF	DSC	CORR	ERR
Check Power Mode				√		√	√	√		√
Execute Drive Diagnostic ¹						√		√		√
Erase Sector(s)	√		√	√	√	√	√	√		√
Flush Cache				√		√	√	√		√
Format Track			√	√	√	√	√	√		√
Identify Device				√		√	√	√		√
Idle				√		√	√	√		√
Idle Immediate				√		√	√	√		√
Initialize Drive Parameters						√		√		√
Key Management Structure Read		√	√	√		√		√		√
Key Management Read Keying Material		√	√	√		√		√		√
Key Management Change Key Management Value		√		√		√	√	√		√
NOP				√		√	√			√
Read Buffer				√		√	√	√		√
Read DMA	√	√	√	√	√	√	√	√	√	√
Read Multiple	√	√	√	√	√	√	√	√	√	√
Read Long Sector	√		√	√	√	√	√	√		√
Read Sector(s)	√	√	√	√	√	√	√	√	√	√
Read Verify Sectors	√	√	√	√	√	√	√	√	√	√
Recalibrate				√		√	√	√		√
Request Sense				√		√		√		√
Security Disable Password				√		√	√	√		√
Security Erase Prepare				√		√	√	√		√
Security Erase Unit				√		√	√	√		√
Security Freeze Lock				√		√	√	√		√
Security Set Password				√		√	√	√		√
Security Unlock				√		√	√	√		√
Seek			√	√		√	√	√		√
Set Features				√		√	√	√		√

Transcend Industrial CF Card (128MB ~ 8GB)

Command	Error Register					Status Register				
	BBK	UNC	IDNF	ABRT	AMNF	DRDY	DWF	DSC	CORR	ERR
Set Multiple Mode				√		√	√	√		√
Set Sleep Mode				√		√	√	√		√
Stand By				√		√	√	√		√
Stand By Immediate				√		√	√	√		√
Translate Sector	√		√	√	√	√	√	√		√
Wear Level	√	√	√	√	√	√	√	√		√
Write Buffer				√		√	√	√		√
Write DMA	√		√	√	√	√	√	√		√
Write Long Sector	√		√	√	√	√	√	√		√
Write Multiple	√		√	√	√	√	√	√		√
Write Multiple w/o Erase	√		√	√	√	√	√	√		√
Write Sector(s)	√		√	√	√	√	√	√		√
Write Sector(s) w/o Erase	√		√	√	√	√	√	√		√
Write Verify	√		√	√	√	√	√	√		√
Invalid Command Code				√		√	√	√		√

Error and Status Register summarizes the valid status and error value for all the CF-ATA Command set.

Transcend Industrial CF Card (128MB ~ 8GB)

CompactFlash Adapters

CompactFlash and CF+ Type I products can be used with a PCMCIA Type I passive adapters. This adapter converts the Type I CompactFlash Storage Card or CF+ Card into a Type II PCMCIA PC card.

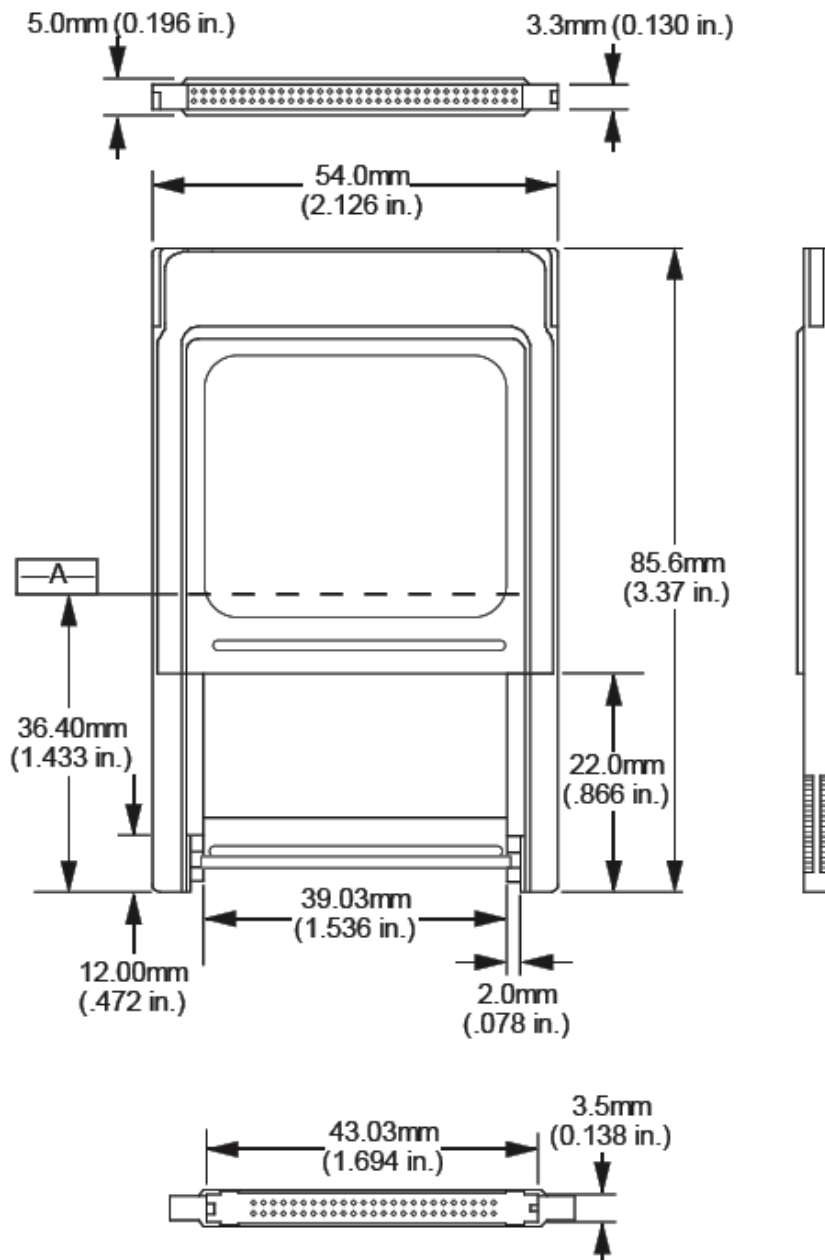

Type I CompactFlash Adapter

Transcend Industrial CF Card (128MB ~ 8GB)

Pinout Differences Between CF Storage Card and CF Adapter

CF Adapter 68 Pin	68 Pin Pin #	50 Pin Pin #	CF Storage/ CF+ Card 50 Pin	CF Adapter 68 Pin	68 Pin Pin #	50 Pin Pin #	CF Storage/ CF+ Card 50 Pin
GND	Pin 1	Pin 1	GND	GND	Pin 35	Pin 1	GND
D03	Pin 2	Pin 2	D03	-CD1	Pin 36	Pin 26	-CD1
D04	Pin 3	Pin 3	D04	D11	Pin 37	Pin 27	D11
D05	Pin 4	Pin 4	D05	D12	Pin 38	Pin 28	D12
D06	Pin 5	Pin 5	D06	D13	Pin 39	Pin 29	D13
D07	Pin 6	Pin 6	D07	D14	Pin 40	Pin 30	D14
-CE1	Pin 7	Pin 7	-CE1 (-CS0)	D15	Pin 41	Pin 31	D15
A10	Pin 8	Pin 8	A10	-CE2	Pin 42	Pin 32	-CE2 (-CS1)
-OE	Pin 9	Pin 9	-OE (_ATA SEL)	-VS1	Pin 43	Pin 33	-VS1
A11	Pin 10			-IORD	Pin 44	Pin 34	-IORD
A09	Pin 11	Pin 10	A09	-IOWR	Pin 45	Pin 35	-IOWR
A08	Pin 12	Pin 11	A08	A17	Pin 46		
A13	Pin 13			A18	Pin 47		
A14	Pin 14			A19	Pin 48		
-WE	Pin 15	Pin 36	-WE	A20	Pin 49		
READY / -IREQ	Pin 16	Pin 37	READY / -IREQ (INTRQ)	A21	Pin 50		
VCC	Pin 17	Pin 13	VCC	VCC	Pin 51	Pin 38	VCC
VPP1	Pin 18			VPP2	Pin 52		
A16	Pin 19			A22	Pin 53		
A15	Pin 20			A23	Pin 54		
A12	Pin 21			A24	Pin 55		
A07	Pin 22	Pin 12	A07	A25	Pin 56	Pin 39	CSEL
A06	Pin 23	Pin 14	A06	-VS2	Pin 57	Pin 40	-VS2
A05	Pin 24	Pin 15	A05	RESET	Pin 58	Pin 41	RESET (-RESET)
A04	Pin 25	Pin 16	A04	-WAIT	Pin 59	Pin 42	-WAIT (IOREADY)
A03	Pin 26	Pin 17	A03	-INPACK	Pin 60	Pin 43	-INPACK (-DMARQ ^D)
A02	Pin 27	Pin 18	A02	-REG	Pin 61	Pin 44	-REG (DMACK ^D)
A01	Pin 28	Pin 19	A01	BVD2 / -SPKR	Pin 62	Pin 45	BVD2 / -SPKR (-DASP)
A00	Pin 29	Pin 20	A00	BVD1 / -STSCHG	Pin 63	Pin 46	BVD1 / -STSCHG (-PDIAG)

Transcend Industrial CF Card (128MB ~ 8GB)

CF Adapter 68 Pin	68 Pin Pin #	50 Pin Pin #	CF Storage/ CF+ Card 50 Pin	CF Adapter 68 Pin	68 Pin Pin #	50 Pin Pin #	CF Storage/ CF+ Card 50 Pin
D00	Pin 30	Pin 21	D00	D08	Pin 64	Pin 47	D08
D01	Pin 31	Pin 22	D01	D09	Pin 65	Pin 48	D09
D02	Pin 32	Pin 23	D02	D10	Pin 66	Pin 49	D10
WP / -IOIS16	Pin 33	Pin 24	WP / -IOIS16 (-IOCS16)	-CD2	Pin 67	Pin 25	-CD2
GND	Pin 34	Pin 50	GND	GND	Pin 68	Pin 50	GND

Transcend Industrial CF Card (128MB ~ 8GB)



Declaration of Compliance with the RoHS Directive

Manufacturer: Transcend Information Inc.

Address: No.70, XING ZHONG RD., NEIHU DIST. TAIPEI, TAIWAN, ROC

Product Name(s): TSxxCF45I/ TSxxCF45IF are RoHS compliant

Transcend Information Inc. certifies that to its knowledge the products listed herein conform to the requirements of "Directive 2002/95/EC of the European Parliament and of the Council on the Restriction of the Use of Certain Hazardous Substances in Electrical and Electronic Equipment."

The compliance of the Transcend product(s) with the requirements of the above mentioned directive have been verified by adhering to the standards for the following prohibited substances:

NO.	Material	Max. Conc.
001	Lead (Pb) and its compounds	<1000ppm
002	Cadmium (Cd) and its compounds	<100ppm
003	Mercury (Hg) and its compounds	<1000ppm
004	Hexavalent Chromium (Cr ⁶⁺) and its compounds	<1000ppm
005	Polybrominated diphenyl ethers (PBDE)	<1000ppm
006	Polybrominated biphenyl (PBB)	<1000ppm

Date : Feb 08th, 2006

SIGNATURE: 

NAME: Ryan Tsai

TITLE: Manufacturing Director

Above technical information is based on industry standard data and tested to be reliable. However, Transcend makes no warranty, either expressed or implied, as to its accuracy and assumes no liability in connection with the use of this product. Transcend reserves the right to make changes in specifications at any time without prior notice.