



**FRONTIER
ELECTRONICS CO., LTD.**

**GBU8-005
THRU
GBU8-10**

8A SILICON SINGLE-PHASE BRIDGE RECTIFIERS

FEATURES

- PLASTIC MATERIAL HAS UNDERWRITERS LABORATORY FLAMMABILITY CLASSIFICATION 94V-0
- IDEAL FOR PRINTED CIRCUIT BOARD
- HIGH TEMPERATURE SOLDERING GUARANTEED : 260°C /10S .375" (9.5mm) LEAD LENGTH AT 5 LBS (2.3KG) TENSION
- GLASS PASSIVATED CHIP JUNCTION

MECHANICAL DATA

- CASE : MOLDED PLASTIC
- TERMINALS : LEADS SOLDERABLE PER MIL-STD-202, METHOD 208
- MOUNTING TORQUE : 5 IN-LB MAX
- MOUNTING POSITION : ANY
- WEIGHT : 4.0 GRAMS

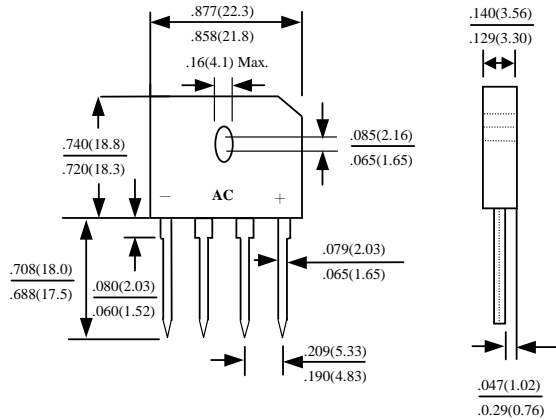

DIMENSIONS IN INCHES AND (MILLIMETERS)

MAXIMUM RATINGS AND ELECTRICAL CHARACTERISTICS
RATINGS AT 25°C AMBIENT TEMPERATURE UNLESS OTHERWISE SPECIFIED
SINGLE PHASE, HALF WAVE, 60 HZ, RESISTIVE OR INDUCTIVE LOAD.
FOR CAPACITIVE LOAD, DERATE CURRENT BY 20%

RATINGS	SYMBOL	GBU8-005	GBU8-01	GBU8-02	GBU8-04	GBU8-06	GBU8-08	GBU8-10	UNITS
MAXIMUM RECURRENT PEAK REVERSE VOLTAGE	V_{RRM}	50	100	200	400	600	800	1000	V
MAXIMUM RMS VOLTAGE	V_{RMS}	35	70	140	280	420	560	700	V
MAXIMUM DC BLOCKING VOLTAGE	V_{DC}	50	100	200	400	600	800	1000	V
MAXIMUM AVERAGE FORWARD RECTIFIED OUTPUT CURRENT (SEE FIG.1)	I_o	8.0							A
PEAK FORWARD SURGE CURRENT SINGLE SINE-WAVE SUPERIMPOSED ON RATED LOAD	I_{FSM}	200							A
STORAGE TEMPERATURE RANGE	T_{STG}	- 55 TO + 150							°C
OPERATING TEMPERATURE RANGE	T_{OP}	- 55 TO + 150							°C

ELECTRICAL CHARACTERISTICS ($A_T T_A = 25^\circ C$ UNLESS OTHERWISE NOTED)

CHARACTERISTICS	SYMBOL	GBU8-005	GBU8-01	GBU8-02	GBU8-04	GBU8-06	GBU8-08	GBU8-10	UNITS
MAXIMUM INSTANTANEOUS FORWARD VOLTAGE DROP PER ELEMENT AT 4.0 A	V_F	1.0							V
MAXIMUM REVERSE LEAKAGE AT RATE DC BLOCKING VOLTAGE PER ELEMENT $T_A=25^\circ C$, $T_C=100^\circ C$	I_R	5							μA

RATINGS AND CHARACTERISTIC CURVES GBU8-005 THRU GBU8-10

FIG. 1 - DERATING CURVE OUTPUT RECTIFIED CURRENT

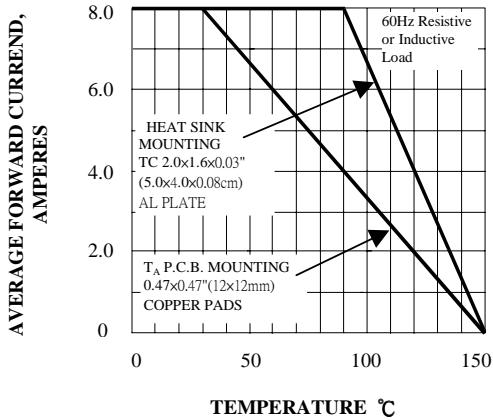

FIG. 2 - MAXIMUM NON-REPETITIVE PEAK FORWARD SURGE CURRENT

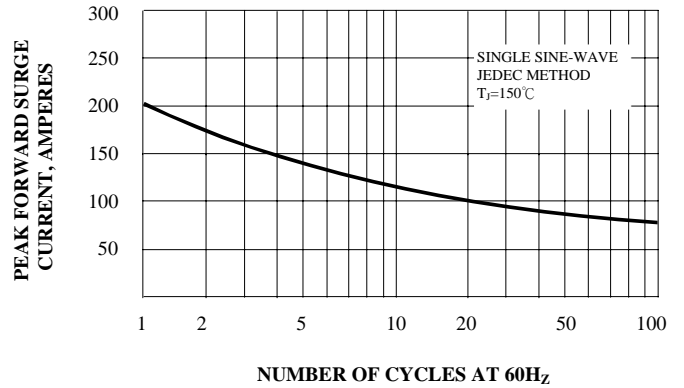

FIG. 3 - TYPICAL JUNCTION CAPACITANCE PER ELEMENT

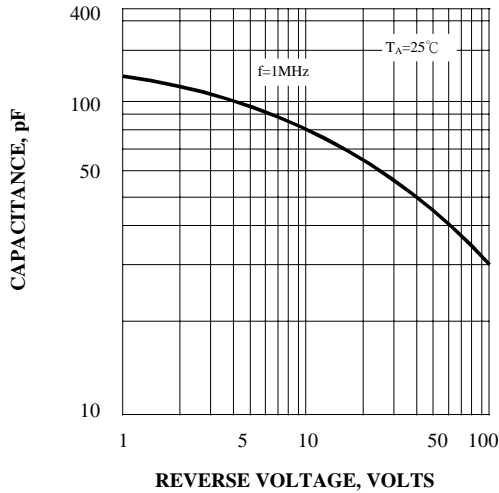

FIG. 4 - TYPICAL JUNCTION CAPACITANCE PER ELEMENT

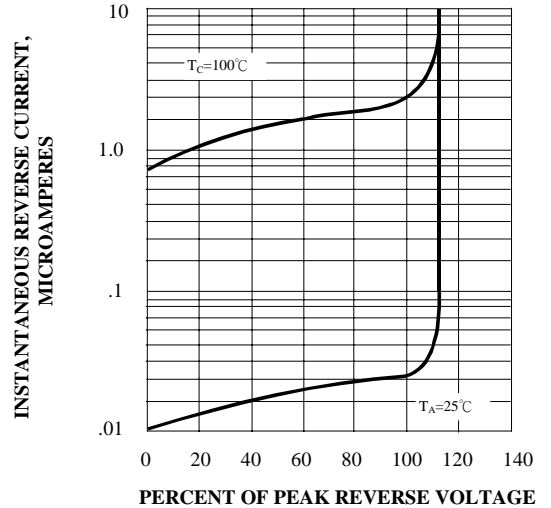

FIG. 5 - TYPICAL INSTANTANEOUS FORWARD CHARACTERISTICS PER ELEMENT

