

0402x2, Resistor Network (Lead / Halogen Free)

1. Scope

This specification applies to 1.0mm x 1.0mm (0404) size resistor network (4P2R) with 2 isolated resistor for use in electronic equipment.

2. Type Designation

RS2N — XXXX — X 2 NH
(1) (2) (3) (4) (5)

Where

- (1) Series No:
0404 Size & 4 Pins 2 Resistors
- (2) Nominal resistance value :
For example —
56R0 = 56Ω
1001 = 1kΩ
00R0 = Jumper
- (3) Resistance tolerance:
F = ± 1.0%
J = ± 5.0%
X = Jumper (below 50mΩ)
- (4) Outline type:
2 = Flat type
- (5) NH = Sn plating (Lead free / Halogen free)

3. Electrical Specifications

Table. 1

Power Rating*	63mW/each element
Resistance Values	3.0Ω , 5.1Ω , 7.5Ω 10 to 1MΩ in E-24 series
Resistance Tolerance	± 1.0% (F)、± 5.0% (J)
T.C.R. (Temperature Coefficient of Resistance)	± 250ppm/°C
Operating Temperature Range	-55°C to 125°C
Maximum Operating Voltage**	25V

Note: *Package Power Temperature Derating Curve

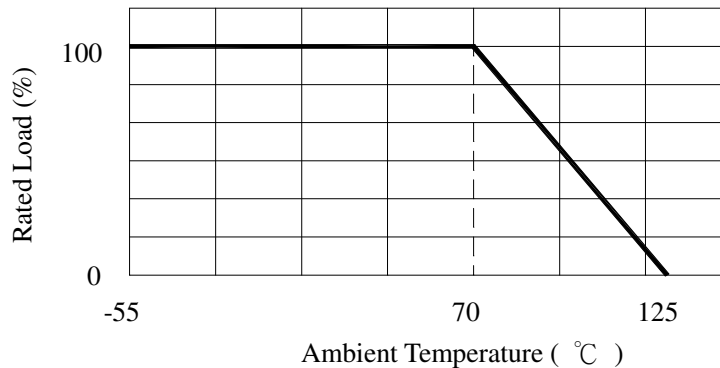

Figure 1. : Power Temperature Derating Curve

Note: **Resistors shall have a rated DC or AC(rms.) continuous operating voltage corresponding to the power rating, as calculated from the following formula

$$V = \sqrt{P \times R}$$

Where V : Rated voltage (V)

P : Rated power (W)

R : Nominal resistance (Ω)

If the voltage so obtained exceeds the maximum operating voltage, this maximum voltage shall be the rated voltage.

Table 2. : Jumper

Resistance Tolerance	Below 50 mΩ
Rated current	1A
Operating Temperature Range	-55°C to 125°C

4. Outline dimensions

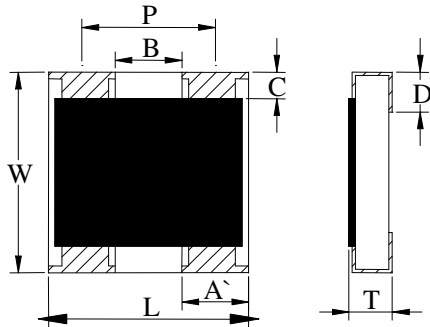

L	1.0 ± 0.05	P	0.65 typical
W	1.0 ± 0.05	C	0.15 ± 0.1
B	0.34 ± 0.1	D	$0.25^{+0.05}_{-0.1}$
T	0.40 ± 0.1	A'	0.33 ± 0.1

Unit: mm

5. Schematics

5-1 Resistor

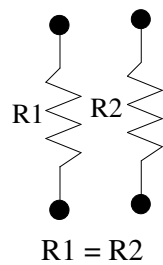

5-2 Jumper

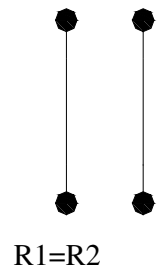

6. Life test

6-1 Electrical

Item	Specification and Requirement		Test Method (Refer to JIS C 5201)
	Resistor	Jumper	
Short Time Overload	$\Delta R: \pm (2.0\% + 0.1\Omega)$ Without damage by flashover, spark, arcing, burning or breakdown	Max. 50m Ω	(1) Applied voltage : 2.5 x rated voltage or 2 x maximum operating voltage which ever is less (2) Test time : 5 seconds
Insulation Resistance	Over 100 M Ω on Overcoat layer face up Over 1,000 M Ω on Substrate side face up		(1) Setup as figure 2 (2) Test voltage : 100 V _{DC} (3) Test time : 60 + 10 / -0 seconds
Voltage Proof	$\Delta R: \pm (1.0\% + 0.05\Omega)$ Without damage by flashover, spark, arcing, burning or breakdown	Max. 50m Ω	(1) Setup as figure 2 (2) Test voltage : 100 V _{AC} (rms.) (3) Test time: 60 +10 / -0 seconds

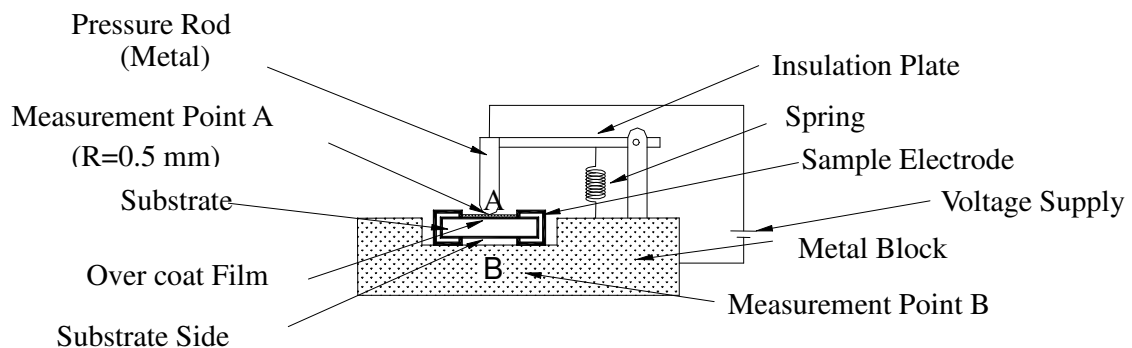

Figure 2 : Measurement Setup

6-2 Mechanical

Item	Specification and Requirement		Test Method (Refer to JIS C 5201)
	Resistor	Jumper	
Solderability	The surface of terminal immersed shall be minimum of 95% covered with a new coating of solder		Solder bath : After immersing in flux, dip in $235 \pm 5^{\circ}\text{C}$ molten solder bath for 2 ± 0.5 seconds
Resistance to Solder Heat	$\Delta R: \pm (1.0\% + 0.05 \Omega)$ Without distinct deformation in appearance	Max. 50m Ω	(1) Pre-heat : $100\sim 110^{\circ}\text{C}$ for 30 seconds (2) Immersed at solder bath of $270 \pm 5^{\circ}\text{C}$ for 10 ± 1 seconds (3) Measuring resistance 1 hour after test
Vibration	$\Delta R: \pm (0.5\% + 0.05\Omega)$ Without mechanical damage such as break		(1) Vibration frequency : (10Hz to 55Hz to 10Hz) in 60 seconds as a period (2) Vibration time : period cycled for 2 hours in each of 3 mutual perpendicular directions (3) Amplitude : 1.5mm
Shock	$\Delta R: \pm (0.25\% + 0.05\Omega)$ Without mechanical damage such as break		(1) Peak value : 490N (2) Duration of pulse : 11ms (3) 3 times in each positive and negative direction of 3 mutual perpendicular directions
Bending Test	$\Delta R: \pm (1.0\% + 0.05\Omega)$ Without mechanical damage such as break		Bending value : 3 mm for 30 ± 1 seconds
Solvent Resistance	Marking should be legible Without mechanical and distinct damage in appearance	Max. 50m Ω	(1) Solvent : Trichloroethane or Isopropyl alcohol (2) Immersed in solvent at room temperature for 90 seconds

6-3 Endurance

Item	Specification and Requirement		Test Method (Refer to JIS C 5201)
	Resistor	Jumper	
Thermal Shock	$\Delta R: \pm (1.0\% + 0.05\Omega)$ Without distinct damage in appearance	Max. 50m Ω	(1) Repeat 5 cycle as follow : (-55 \pm 3 $^{\circ}$ C ,30minutes) →(Room temperature, 2~3 minutes) →(+125 \pm 2 $^{\circ}$ C ,30minutes) →(Room temperature, 2~3 minutes) (2) Measuring resistance 1 hour after test
Moisture with Load	$\Delta R: \pm (3.0\% + 0.1\Omega)$ Without distinct damage in appearance Marking should be legible	Max. 50m Ω	(1) Environment condition : 40 \pm 2 $^{\circ}$ C ,90~95% RH (2) Applied Voltage : Rated voltage (3) Test period : (1.5 hour ON) →(0.5 hour OFF) cycled for total 1,000 + 48 / - 0 hours (4) Measuring resistance 1 hour after test
Load Life	$\Delta R: \pm (3.0\% + 0.1\Omega)$ Without distinct damage in appearance	Max. 50m Ω	(1) Test temperature : 70 \pm 2 $^{\circ}$ C (2) Applied Voltage : rated voltage (3) Test period : (1.5 hour ON) →(0.5 hour OFF) cycled for total 1,000 + 48 / - 0 hours (4) Measuring resistance 1 hour after test
Low Temperature Store	$\Delta R: \pm (3.0\% + 0.1\Omega)$ Without distinct damage in appearance	Max. 50m Ω	(1) Store temperature : -55 \pm 3 $^{\circ}$ C for total 1,000 + 48 / - 0 hours (2) Measuring resistance 1 hour after test
High Temperature Store	$\Delta R: \pm (3.0\% + 0.1\Omega)$ Without distinct damage in appearance	Max. 50m Ω	(1) Store temperature : +125 \pm 2 $^{\circ}$ C for total 1,000 + 48 / - 0 hours (2) Measuring resistance 1 hour after test

7. Recommend Land Pattern Dimensions

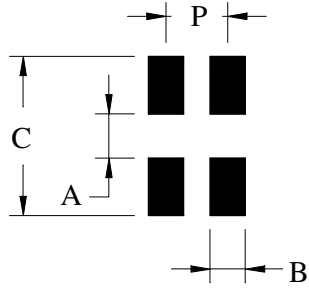

A	0.5
B	0.25
P	0.65
C	1.8

Unit : mm

8-2 Peel force of top cover tape

The peel speed shall be about 300 mm/minute

The peel force of top cover tape shall be between 0.1 to 0.7 N

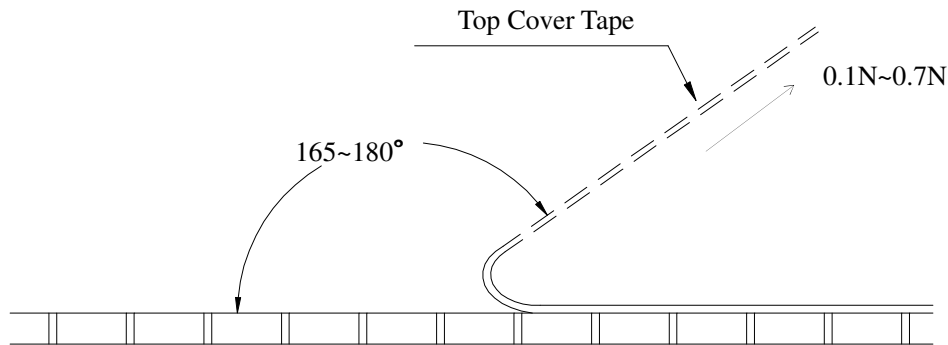

8-3 Numbers of taping

10,000 pieces/reel

8-4 Label marking

The following items shall be marked on the production and shipping Label on the reel.

8-4-1 Production Label

- (1) Part No.
- (2) Description
- (3) Quantity
- (4) Taping No.

8-4-2 Shipping Label

- (1) *Customer's name
- (2) *Customer's part No.
- (3) Manufacturer's part No.
- (4) Manufacturer's name
- (5) Manufacturer's country

*Note : Item (1) and (2) are listed by request

9. Care note

9-1 Care note for storage

- (1) Resistor network shall be stored in a room where temperature and humidity must be controlled. (temperature 5 to 35°C, humidity 45 to 85% RH) However, a humidity keep it low, as it is possible.
- (2) Resistor network shall be stored as direct sunshine doesn't hit on it.
- (3) Resistor network shall be stored with no moisture, dust, a material that will make solderability inferior, and a harmful gas (Chloridation hydrogen, sulfurous acid gas, and sulfuration hydrogen)

9-2 Care note for operating and handling

- (1) It is necessary to protect the edge and protection coat of resistors from mechanical stress.
- (2) Handle with care when printing circuit board (PCB) is divided or fixed on support body, because bending of printing circuit board (PCB) mounting will make mechanical stress for resistors.
- (3) Resistors shall be used with in rated range shown in specification. Especially, if voltage more than specified value will be loaded to resistor, there is a case it will make damage for machine because of temperature rise depending on generating of heat, and increase resistance value or breaks.
- (4) In case that resistor is loaded a rated voltage, it is necessary to confirms temperature of a resistor and to reduce a load power according to load reduction curve, because a temperature rise of a resistor depends on influence of heat from mounting density and neighboring element.
- (5) Observe Limiting element voltage and maximum overload voltage specified in each specification
- (6) If there is possibility that a large voltage (pulse voltage, shock voltage) charge to resistor, it is necessary that operating condition shall be set up before use.