

Low-Power CMOS Ionization Smoke Detector with Interconnect and Timer

The MC14568, when used with an ionization chamber and a small number of external components, will detect smoke. When smoke is sensed, an alarm is sounded via an external piezoelectric transducer and internal drivers. This circuit is designed to operate in smoke detector systems that comply with UL217 and UL268 specifications.

An internal oscillator with associated logic controls the overall functionality by powering down the device for 1.67 seconds and sensing smoke in a 10 ms window. In this way, standby current consumption is reduced to between 5.0 and 9.0 μA , thus providing longer battery life. In addition, a networking capability allows as many as 125 to be interconnected so that if any unit senses smoke, all units will sound an alarm.

The MC14568 is supplied in a 16-pin dual in-line plastic package and is designed to run on a power supply between 6 to 12 Volts.

Features

- Speed-Up Sampling Rate of 40 ms of Internal Clock Period (Pin 12) After First Detection of Smoke
- Timer Function for Reduced Sensitivity for a Nominal Period of 6.43 Minutes (10 Minutes Max)
- High-Smoke Detection in the "Reduced Sensitivity" Mode
- Internal and External Low Battery Threshold
- Internal and External Smoke Reference Settings
- Guaranteed Power Up Without Random LED and Horn Chirps
- Reversed Battery Protection
- Low Leakage Detect Pin
- Metal Option to Add Double Chirp at End of Reduced Sensitivity Period; Default is No Chirp
- Pb-Free Packaging Designated by Suffix Code ED

ORDERING INFORMATION

Device	Case No.	Package
PC14568P/R2	648-08	Plastic Dip
PC14568ED/R2		

MC14568

**LOW-POWER CMOS IONIZATION
SMOKE DETECTOR WITH
INTERCONNECT AND TIMER**

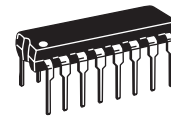

**P SUFFIX
ED SUFFIX (PB-FREE)
PLASTIC DIP
CASE 648-08**

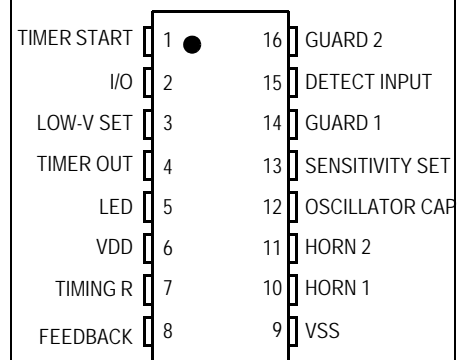

Figure 1. Pin Connections

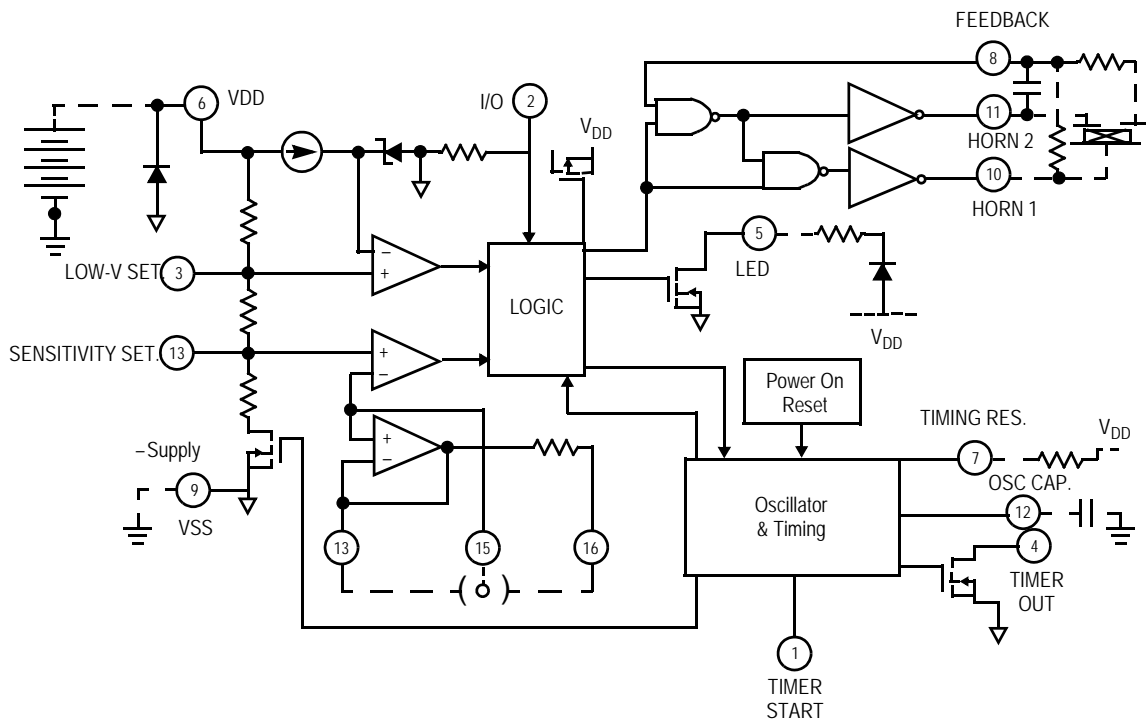

Figure 2. Functional Block Diagram

Table 1. Maximum Ratings

Rating	Symbol	Value	Unit
Supply Voltage Range	V_{DD}	-0.5 to +15	V
Input Voltage Range	V_{IN}	-0.3 to $V_{DD} + 0.3$	V
Maximum Current (Source/Sink) by Pins 6 (VDD) and Pin 9 (VSS)	I_{DS}	30	mA
Maximum Current Input Pins	I_{IN}	± 10	mA
Maximum Current Output Pins (Pins 2, 4, 5, 10, 11)	—	± 25	mA
Maximum Current (Pin 15)	—	± 1.0	mA
Operating Temperature Range	T_A	0 to +50	$^{\circ}\text{C}$
Storage Temperature Range	T_{STG}	-55 to +125	$^{\circ}\text{C}$
Human Body Model ESD Rating	V_{ESD}	1000	V

CAUTION: CMOS devices have input static protection but are susceptible to damage when exposed to extremely high static electrical charges.

Table 2. Electrical Characteristics

Characteristics noted under conditions $T_A = +25^\circ\text{C}$, $V_{DD} = 9.0\text{ V}$, $V_{SS} = 0\text{ V}$, $C_{12} = 0.1\ \mu\text{F}$ (Oscillator Pin) $R7 = 8.2\ \text{m}\Omega/\text{fn}$ (timing resistor pin) unless otherwise noted.

Symbol	Characteristic	Test Condition	Test Pin	Min	Typ	Max	Unit
V_{DD}	Supply Voltage Range	Operating	6	6.0	9.0	12	V
I_{IN}	Detector Input Current	0 to 40% RH, $V_{IN} = 0$ to 9.0 V	15	—	—	1.0	pA
V_{OS}	Input Offset Voltage	Active Guard Active Guard Detect Comparator	14 – 15 16 – 15 15 – 13	— — —	— — —	100 100 50	mV
V_{HYS}	Hysteresis	No Alarm to Alarm	13	80	130	160	mV
V_{CM}	Common Mode Range	Guard Amplifier Smoke Comparator	14 – 15 13 – 15	0.5 0.5	— —	$V_{DD} - 2.0$ $V_{DD} - 2.0$	V
LO-Z HI-Z	Active Guard Impedance	To V_{CC} To V_{CC}	14 16	— —	10 500	— —	k Ω
t_{CL}	Oscillator Period	No Alarm Alarm	12	1.34 32	1.67 40	2.0 48	s ms
	Timer Out Pulse Width		4	8.0	10	12	ms
	Timer Period	After Pin 1 High to Low, No Smoke	4	—	6.43	10	min
V_{TH}	Low Voltage Threshold	$T_A = 0$ to 50°C	6	7.2	—	7.8	V
	Sensitivity Adj. Voltage	V_{13}/V_{DD} , Pin 3 Open Circuit	13	48.5	50	51.5	%
	Low Battery Threshold	Pin 3 Open Circuit	3	60.6	63	65.6	%
	Horn Output Voltage	$I_{OUT} = 16\text{ mA}$, $V_{DD} = 9.0\text{ V}$ $I_{OUT} = 16\text{ mA}$, $V_{DD} = 7.2\text{ V}$ $I_{OUT} = -16\text{ mA}$, $V_{DD} = 9.0\text{ V}$ $I_{OUT} = -16\text{ mA}$, $V_{DD} = 7.2\text{ V}$	10 – 11	— — 8.5 6.3	0.1 — 8.8 —	0.5 0.9 — —	V
PW_{ON}	Horn Output ON Time	Alarm Low Battery	10 – 11	450 8.0	500 10	550 12	ms
PW_{OFF}	Horn Output OFF Time	Alarm Alarm Low Battery	10 – 11	450 1350 32	500 1500 40	550 1650 48	ms
	Feedback	V_{IH} V_{IL}	8	6.3 —	— —	— 2.7	V
	Timer Start Logic Levels	V_{IH} V_{IL}	1	4.5 —	— —	— 2.5	V
	Timer Start Input Current	$V_{IN} = 9.0\text{ V}$	1	20	—	80	μA
	Timer Out Output Current	$V_{OUT} = 0.5\text{ V}$	4	500	—	—	μA
I_{LON}	LED Output ON Current	$V_{DD} = 7.2\text{ V}$, $V_{OUT} = 1.0\text{ V}$	5	10	—	—	mA
t_{LON}	LED Output ON Time	No Local Alarm, Not Latched	5	8.0	10	12	ms
t_{LOFF}	LED Output OFF Time	No Alarm, Standby No Alarm, Timer Mode	5	32 8.0	40 10	48 12	s

Table 2. Electrical Characteristics (continued)

Characteristics noted under conditions $T_A = +25^\circ\text{C}$, $V_{DD} = 9.0\text{ V}$, $V_{SS} = 0\text{ V}$, $C_{12} = 0.1\ \mu\text{F}$ (Oscillator Pin) $R7 = 8.2\ \text{m}\Omega/\text{fn}$ (timing resistor pin) unless otherwise noted.

Symbol	Characteristic	Test Condition	Test Pin	Min	Typ	Max	Unit
$I_{I/O}$	I/O Current ⁽¹⁾ $V_{I/O} = V_{DD} - 2.0\text{ V}$ $V_{I/O} = V_{DD} - 2.0\text{ V}$ $V_{I/O} = 1.0\text{ V}$	No Alarm Alarm Charge Dump	2	25 -75 5.0	— — —	60 — —	μA mA mA
	I/O Charge Dump Duration	After Local Alarm or Test	2	1.33	1.66	1.99	s
	I/O Delay	Alarm Out	2	—	3.0	—	s
$V_{I/O}$	I/O V_{IH} , V_{IL}	V_{IH} , $V_{DD} = 9.0\text{ V}$ V_{IL} , $V_{DD} = 9.0\text{ V}$	2	3.2 —	— —	— 1.5	V
I_{DD}	Supply Current $V_{DD} = 9.0\text{ V}$ $V_{DD} = 12\text{ V}$	No Alarm, No Loads No Alarm, No Loads	6	— —	5.0 —	9.0 12	μA

1. This specification also shows V_{OH} of $V_{DD} - 2.0\text{ V}$ and V_{OL} of 1.0 V at respective currents.
2. Negative current is defined as coming out of (sourcing) the specified device pin.
3. Alarm (Smoke) Condition is defined as $V_{15} < V_{13}$; No Alarm (No Smoke) Condition as $V_{15} > V_{13}$.
4. No Loads means the IC in standby mode with a $0.1\ \mu\text{F}$ capacitor on pin 12 to VSS and an $8.2\ \text{M}\Omega$ resistor on pin 7 to VDD with Pin 2 tied low (LED and Horn are off).

PIN DESCRIPTIONS

TIMER START (PIN 1)

An internal timer is provided that can be used in various configurations to allow for a period of reduced smoke detector sensitivity (“hush”). When a high-to-low transition occurs at pin 1, the internal timer is reset, the timer mode enabled, and the circuit reset to a no alarm condition.

I/O (PIN 2)

Pin 2 is an input/output pin designed to be connected to other smoke units for remote smoke sensing. In a local smoke condition, this pin is driven high by the unit sensing smoke. All other units in the network will then go into remote smoke mode.

LOW-V SET (PIN 3)

Pin 3 is the low voltage set pin. This pin has an internal fixed bias to monitor the battery. Using an external resistor from pin 3 to either VDD or VSS allows the user to change this bias to some fraction of V_{DD} .

TIMER OUTPUT (PIN 4)

This pin is an open drain output that can be used in various timer configurations to alter the IC’s sensitivity. A high to low transition on pin 1 causes this output to pulse for 231 internal clock cycles.

LED (PIN 5)

This pin is the LED cathode connection pin and is driven low when the LED pulses.

VDD (PIN 6)

This is the positive power supply for the entire IC.

TIMING RESISTOR (PIN 7)

This pin, when tied through a resistor to VDD, works along with pin 12 to set the bias current that controls the oscillation frequency.

FEEDBACK (PIN 8)

This is the feedback pin used for driving the piezo electric element.

VSS (PIN 9)

This is the negative power supply pin for the entire IC (usually ground).

HORN 1 (PIN 10)

This is one of two pins that drive the horn element (i.e., brass and silver).

HORN 2 (PIN 11)

This is one of two pins that drive the horn element (i.e., brass and silver).

OSCILLATOR CAP (PIN 12)

This pin, when tied to a low leakage capacitor to VSS, works with pin 7 to set the internal oscillation frequency.

SENSITIVITY SET (PIN 13)

This pin is set internally to provide the reference sensitivity for the detect pin (pin 15).

An external resistor from pin 13 to either VDD or VSS can adjust the sensitivity.

GUARD 1/LOW Z (PIN 14)

This pin provides a low impedance guard for the detect pin (pin 15) to reduce leakage currents.

DETECT INPUT PIN (PIN 15)

This pin functions as a low leakage smoke detect pin when used in conjunction with an Ionization type element.

GUARD 2/HIGH Z (PIN 16)

This pin provides a high impedance guard for the detect pin (pin 15) to reduce leakage currents.

DEVICE OPERATION

In a NO SMOKE condition (i.e., standby mode with detect pin 15 higher than internal reference pin 13), the oscillator operates with a period of 1.67 s and the LED will flash once every 24-clock periods (or every 40 s).

The smoke detect pin (pin 15) is connected to the ionization chamber and leads to the inverting input of a CMOS detect comparator. The voltage on this pin is compared to an internal reference voltage on the non-inverting input of the detect comparator set up by a resistor divider network and a FET switch (*this reference voltage can be increased or decreased by an external resistor from pin 13 to VDD or VSS*).

Periodically (every 1.67 s and for a 10 ms window) power is supplied to the entire IC and a check is made for a SMOKE condition. During this window the FET switch is turned on and the detect pin voltage (pin 15) is compared to the internal reference voltage (pin 13). If the detect pin is lower than the reference this indicates a SMOKE condition.

A SMOKE condition speeds up the internal oscillator, which now oscillates with an internal period of 40 ms (the rising edge of the saw tooth periodic signal on pin 12 remains the same while the falling edge falls faster in a SMOKE condition).

Furthermore, a SMOKE condition causes the resistor divider network that sets the smoke detect reference voltage to change in such a way as to make the reference voltage increase by approximately 130 mV (with no external connections to pin 13 or to pin 3).

This provides hysteresis and reduces false triggering. This hysteresis is turned off when the IC exits a SMOKE condition and returns to standby mode.

Once in a SMOKE condition, the LED will flash every 24-clock cycles (once every second). The horn (piezo electric element) driver is activated during a smoke condition with a typical ON/OFF time of 160 ms ON, 80 ms OFF.

During the off time, the IC re-checks to see if a SMOKE condition still exists. If no smoke is detected the horn driver is suppressed. During a SMOKE condition the low voltage battery check is inhibited.

NO SMOKE AND LOW BATTERY CHECK

During a NO SMOKE condition (i.e., standby mode) the LED is pulsed to load the battery every 24-clock cycles (every 40 seconds) and a fraction of the battery voltage (set internally by a resistor divider network and pulsed "ON" by a internal FET) is compared to an internal reference voltage set by a reversed biased Zener diode by an internal CMOS comparator. The fraction of the supply voltage (pin 3) to be compared to the internal reference voltage for low battery check can be raised or lowered by connecting an external resistor between pin 3 and VDD or pin 3 and VSS. If low battery is detected a warning "chirp" will be sounded by the horn driver once every 24-clock cycles (a low battery condition does NOT cause the oscillator to speed up as does a SMOKE condition). Low battery check will still be performed in reduced sensitivity mode and a low battery chirp will be heard if V_{DD} falls below specified value.

TIMER

An internal timer is provided that can be used in various configurations to allow for a period of reduced smoke detector sensitivity.

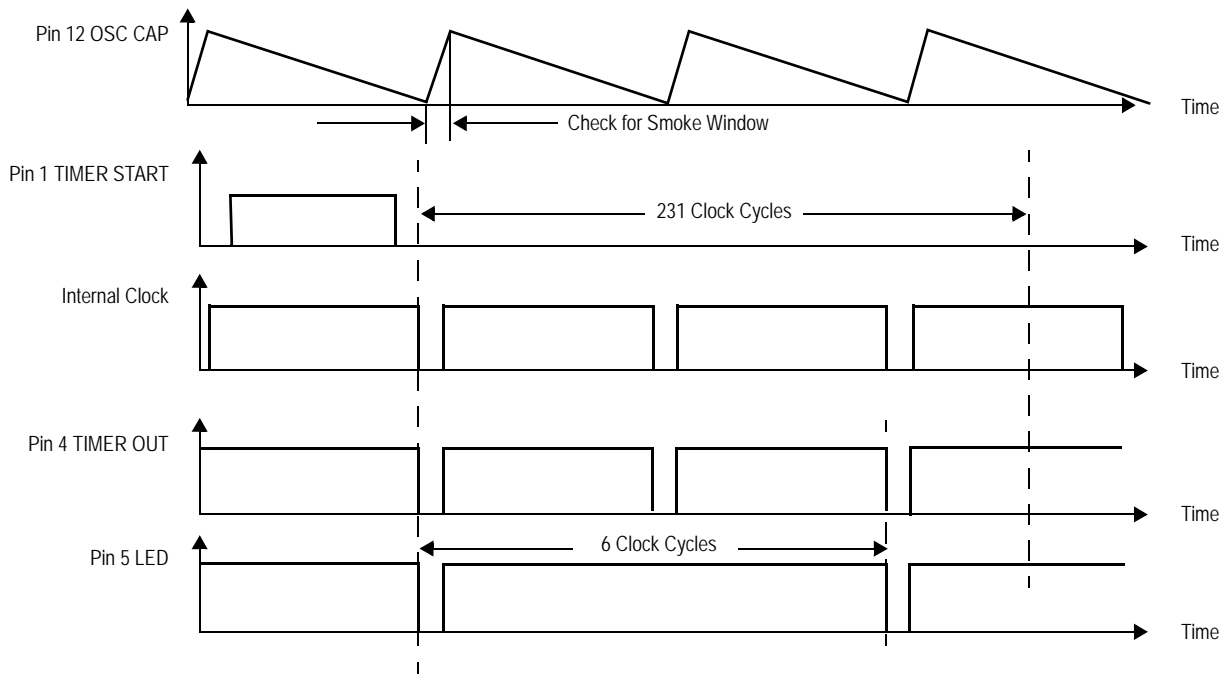

Figure 3. MC14568 Timing Diagram for the Timer Circuit

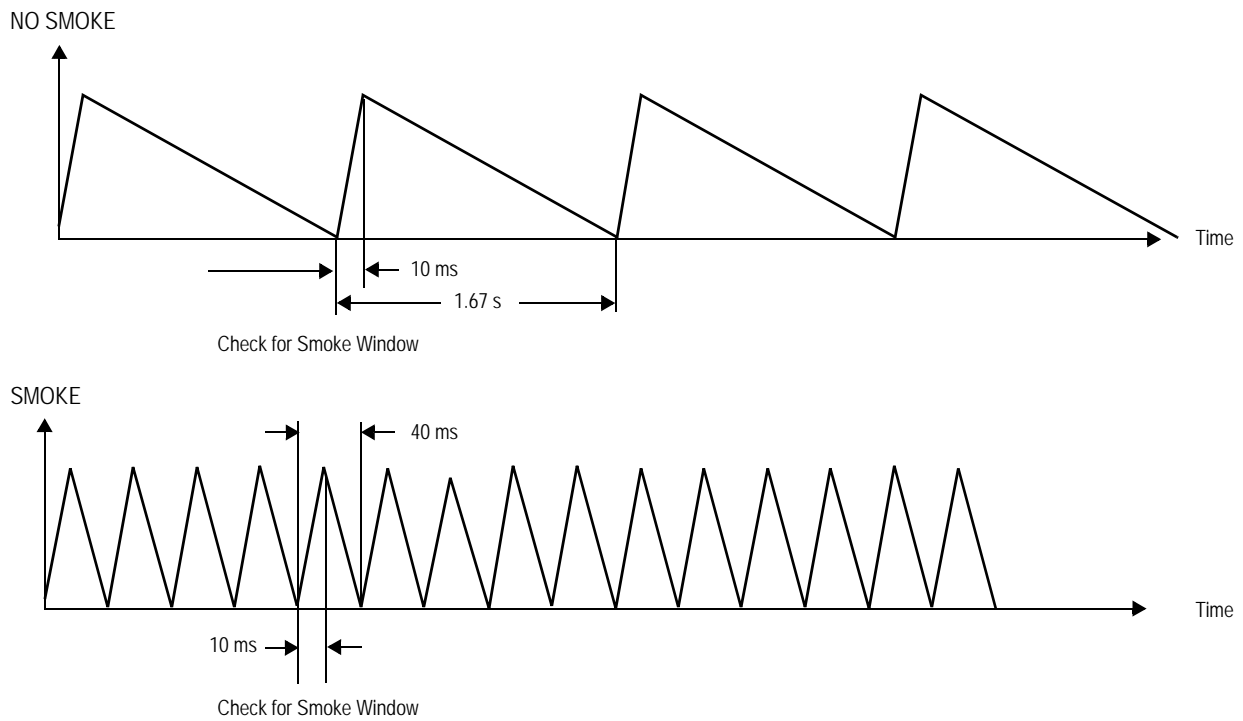
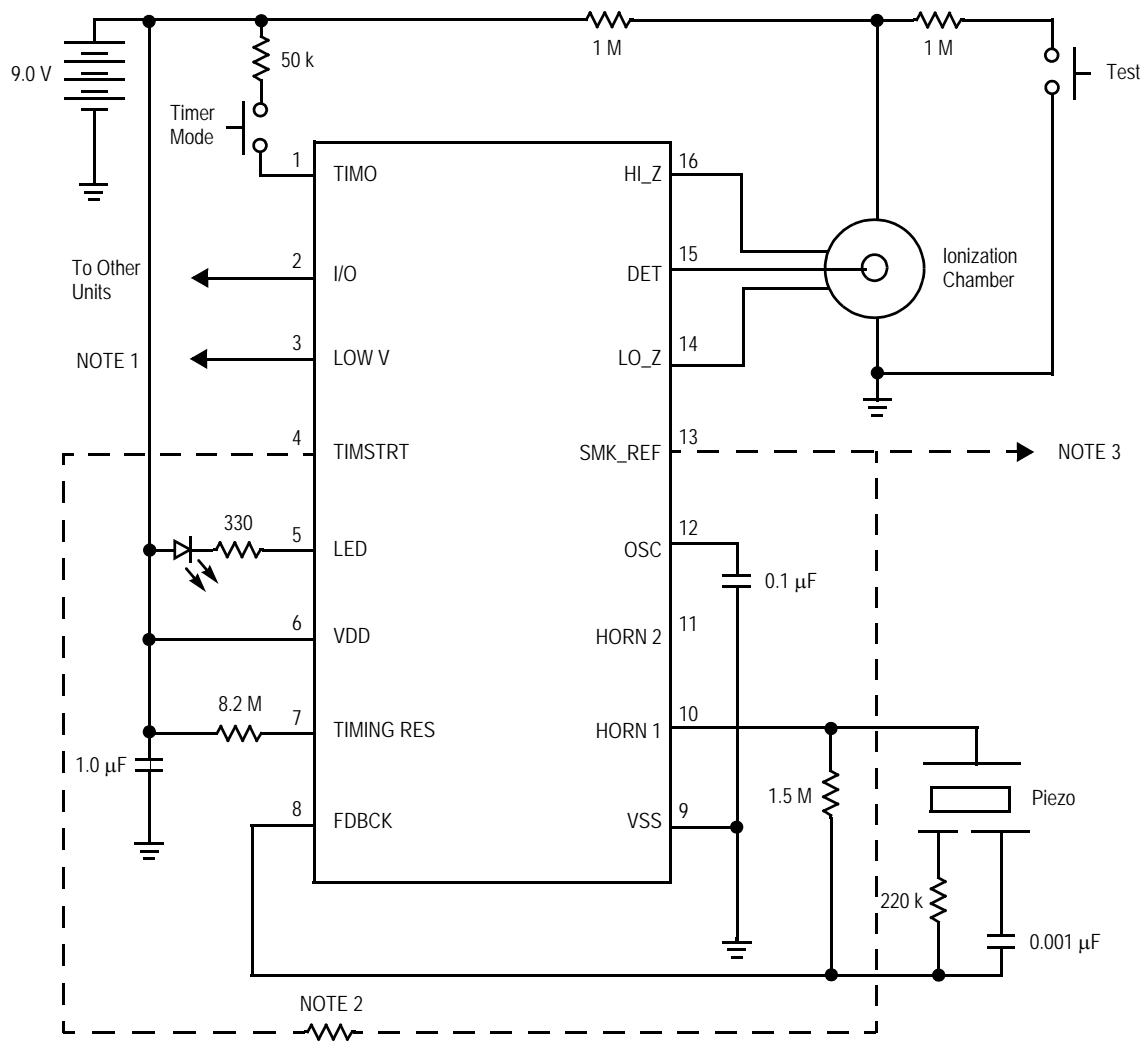

Figure 4. MC14568 Oscillator Waves in Stand By and Smoke Conditions



- NOTE 1: The low voltage set point can be tailored to customer's requirement with the use of an external resistor.
- NOTE 2: The sensitivity adjustment set point during the timer mode can be tailored to the customer's requirement with the use of an external resistor.
- NOTE 3: The Smoke Reference set point can be tailored to the customer's requirement with the use of an external resistor.

Figure 5. MC14568 Typical Application Diagram

PACKAGE DIMENSIONS

The **MC14568** is supplied in a low-cost, 16-pin dual in-line plastic package. It is rated for continuous operation over the temperature range of 0°C to +50°C.

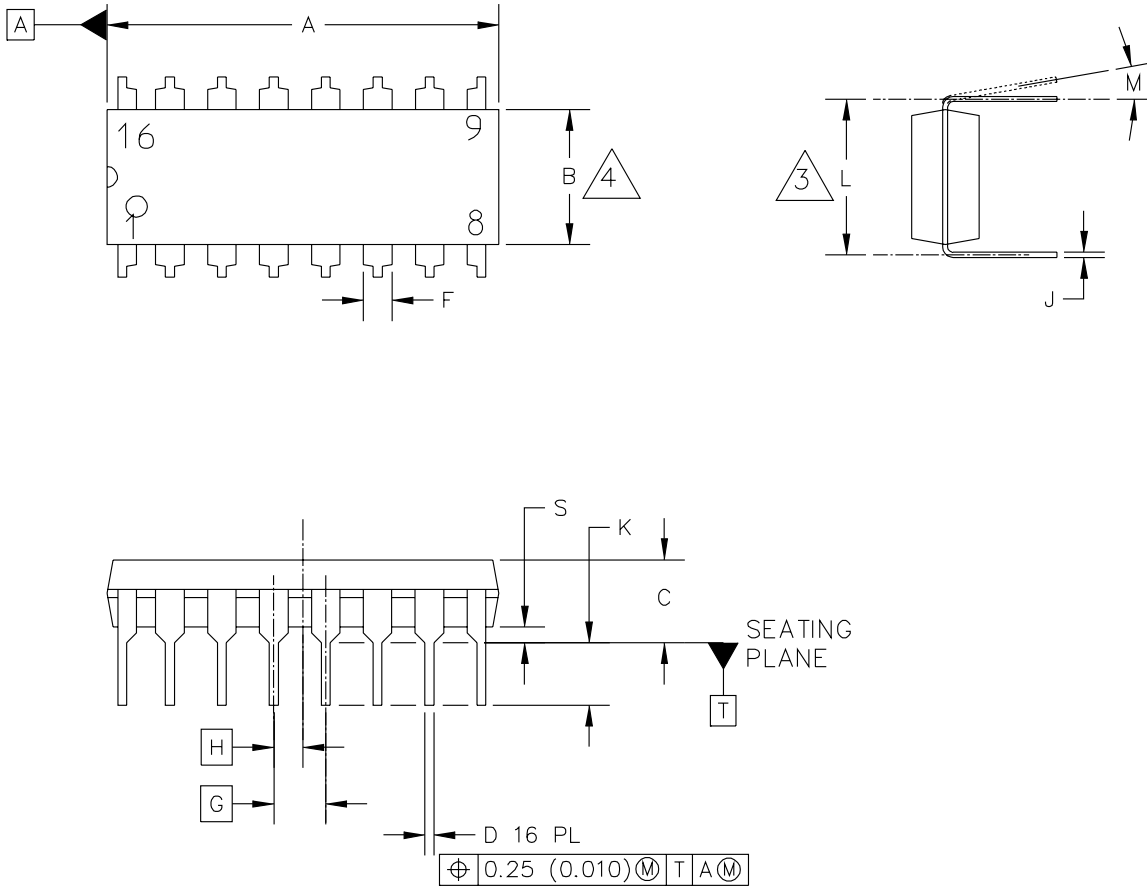

© FREESCALE SEMICONDUCTOR, INC. ALL RIGHTS RESERVED.	MECHANICAL OUTLINE	PRINT VERSION NOT TO SCALE	
TITLE: 16 LD PDIP	DOCUMENT NO: 98ASB42431B		REV: T
	CASE NUMBER: 648-08		19 MAY 2005
	STANDARD: NON-JEDEC		

PAGE 1 OF 3

**CASE 648-08
 ISSUE T
 16-LEAD PLASTIC DIP**

MC14568

PACKAGE DIMENSIONS

NOTES:

1. DIMENSIONING AND TOLERANCING PER ASME Y14.5M, 1994.
2. CONTROLLING DIMENSION: INCH.
3. DIMENSION TO CENTER OF LEADS WHEN FORMED PARALLEL.
4. DIMENSIONS DOES NOT INCLUDE MOLD FLASH.
5. ROUNDED CORNERS OPTIONAL.
6. 648-01 THRU -08 OBSOLETE, NEW STANDARD 648-09.

DIM	MILLIMETERS		INCHES		DIM	MILLIMETERS		INCHES	
	MIN	MAX	MIN	MAX		MIN	MAX	MIN	MAX
A	18.80	19.55	0.740	0.770					
B	6.35	6.85	0.250	0.270					
C	3.69	4.44	0.145	0.175					
D	0.39	0.53	0.015	0.021					
F	1.02	1.77	0.040	0.070					
G	2.54 BSC		0.100 BSC						
H	1.27 BSC		0.050 BSC						
J	0.21	0.38	0.008	0.015					
K	2.80	3.30	0.110	0.130					
L	7.50	7.74	0.295	0.305					
M	0°	10°	0°	10°					
S	0.51	1.01	0.020	0.040					
© FREESCALE SEMICONDUCTOR, INC. ALL RIGHTS RESERVED.			MECHANICAL OUTLINE		PRINT VERSION NOT TO SCALE				
TITLE: 16 LD PDIP					DOCUMENT NO: 98ASB42431B			REV: T	
					CASE NUMBER: 648-08			19 MAY 2005	
					STANDARD: NON-JEDEC				

PAGE 2 OF 3

**CASE 648-08
ISSUE T
16-LEAD PLASTIC DIP**

MC14568

PACKAGE DIMENSIONS

STYLE 1:

- PIN 1. CATHODE
- 2. CATHODE
- 3. CATHODE
- 4. CATHODE
- 5. CATHODE
- 6. CATHODE
- 7. CATHODE
- 8. CATHODE
- 9. ANODE
- 10. ANODE
- 11. ANODE
- 12. ANODE
- 13. ANODE
- 14. ANODE
- 15. ANODE
- 16. ANODE

STYLE 2:

- PIN 1. COMMON DRAIN
- 2. COMMON DRAIN
- 3. COMMON DRAIN
- 4. COMMON DRAIN
- 5. COMMON DRAIN
- 6. COMMON DRAIN
- 7. COMMON DRAIN
- 8. COMMON DRAIN
- 9. GATE
- 10. SOURCE
- 11. GATE
- 12. SOURCE
- 13. GATE
- 14. SOURCE
- 15. GATE
- 16. SOURCE

© FREESCALE SEMICONDUCTOR, INC. ALL RIGHTS RESERVED.	MECHANICAL OUTLINE	PRINT VERSION NOT TO SCALE	
TITLE: 16 LD PDIP	DOCUMENT NO: 98ASB42431B	REV: T	
	CASE NUMBER: 648-08	19 MAY 2005	
	STANDARD: NON-JEDEC		

PAGE 3 OF 3

**CASE 648-08
ISSUE T
16-LEAD PLASTIC DIP**

How to Reach Us:

Home Page:

www.freescale.com

E-mail:

support@freescale.com

USA/Europe or Locations Not Listed:

Freescale Semiconductor
Technical Information Center, CH370
1300 N. Alma School Road
Chandler, Arizona 85224
+1-800-521-6274 or +1-480-768-2130
support@freescale.com

Europe, Middle East, and Africa:

Freescale Halbleiter Deutschland GmbH
Technical Information Center
Schatzbogen 7
81829 Muenchen, Germany
+44 1296 380 456 (English)
+46 8 52200080 (English)
+49 89 92103 559 (German)
+33 1 69 35 48 48 (French)
support@freescale.com

Japan:

Freescale Semiconductor Japan Ltd.
Headquarters
ARCO Tower 15F
1-8-1, Shimo-Meguro, Meguro-ku,
Tokyo 153-0064
Japan
0120 191014 or +81 3 5437 9125
support.japan@freescale.com

Asia/Pacific:

Freescale Semiconductor Hong Kong Ltd.
Technical Information Center
2 Dai King Street
Tai Po Industrial Estate
Tai Po, N.T., Hong Kong
+800 2666 8080
support.asia@freescale.com

For Literature Requests Only:

Freescale Semiconductor Literature Distribution Center
P.O. Box 5405
Denver, Colorado 80217
1-800-441-2447 or 303-675-2140
Fax: 303-675-2150
LDCForFreescaleSemiconductor@hibbertgroup.com

RoHS-compliant and/or Pb-free versions of Freescale products have the functionality and electrical characteristics of their non-RoHS-compliant and/or non-Pb-free counterparts. For further information, see <http://www.freescale.com> or contact your Freescale sales representative.

For information on Freescale's Environmental Products program, go to <http://www.freescale.com/epp>.

Information in this document is provided solely to enable system and software implementers to use Freescale Semiconductor products. There are no express or implied copyright licenses granted hereunder to design or fabricate any integrated circuits or integrated circuits based on the information in this document.

Freescale Semiconductor reserves the right to make changes without further notice to any products herein. Freescale Semiconductor makes no warranty, representation or guarantee regarding the suitability of its products for any particular purpose, nor does Freescale Semiconductor assume any liability arising out of the application or use of any product or circuit, and specifically disclaims any and all liability, including without limitation consequential or incidental damages. "Typical" parameters that may be provided in Freescale Semiconductor data sheets and/or specifications can and do vary in different applications and actual performance may vary over time. All operating parameters, including "Typicals", must be validated for each customer application by customer's technical experts. Freescale Semiconductor does not convey any license under its patent rights nor the rights of others. Freescale Semiconductor products are not designed, intended, or authorized for use as components in systems intended for surgical implant into the body, or other applications intended to support or sustain life, or for any other application in which the failure of the Freescale Semiconductor product could create a situation where personal injury or death may occur. Should Buyer purchase or use Freescale Semiconductor products for any such unintended or unauthorized application, Buyer shall indemnify and hold Freescale Semiconductor and its officers, employees, subsidiaries, affiliates, and distributors harmless against all claims, costs, damages, and expenses, and reasonable attorney fees arising out of, directly or indirectly, any claim of personal injury or death associated with such unintended or unauthorized use, even if such claim alleges that Freescale Semiconductor was negligent regarding the design or manufacture of the part.

Freescale™ and the Freescale logo are trademarks of Freescale Semiconductor, Inc. All other product or service names are the property of their respective owners.

© Freescale Semiconductor, Inc. 2006. All rights reserved.