

MC14553B

3-Digit BCD Counter

The MC14553B 3-digit BCD counter consists of 3 negative edge triggered BCD counters that are cascaded synchronously. A quad latch at the output of each counter permits storage of any given count. The information is then time division multiplexed, providing one BCD number or digit at a time. Digit select outputs provide display control. All outputs are TTL compatible.

An on-chip oscillator provides the low-frequency scanning clock which drives the multiplexer output selector.

This device is used in instrumentation counters, clock displays, digital panel meters, and as a building block for general logic applications.

- TTL Compatible Outputs
- On-Chip Oscillator
- Cascadable
- Clock Disable Input
- Pulse Shaping Permits Very Slow Rise Times on Input Clock
- Output Latches
- Master Reset

MAXIMUM RATINGS* (Voltages Referenced to V_{SS})

Symbol	Parameter	Value	Unit
V_{DD}	DC Supply Voltage	- 0.5 to + 18.0	V
V_{in}, V_{out}	Input or Output Voltage (DC or Transient)	- 0.5 to $V_{DD} + 0.5$	V
I_{in}	Input Current (DC or Transient), per Pin	± 10	mA
I_{out}	Output Current (DC or Transient), per Pin	+ 20	mA
P_D	Power Dissipation, per Package†	500	mW
T_{stg}	Storage Temperature	- 65 to + 150	°C
T_L	Lead Temperature (8-Second Soldering)	260	°C

* Maximum Ratings are those values beyond which damage to the device may occur.

† Temperature Derating:

Plastic "P and D/DW" Packages: - 7.0 mW/°C From 65°C To 125°C

Ceramic "L" Packages: - 12 mW/°C From 100°C To 125°C

TRUTH TABLE

Inputs				Outputs
Master Reset	Clock	Disable	LE	
0		0	0	No Change
0		0	0	Advance
0	X	1	X	No Change
0	1		0	Advance
0	1		0	No Change
0	0	X	X	No Change
0	X	X		Latched
0	X	X	1	Latched
1	X	X	0	$Q_0 = Q_1 = Q_2 = Q_3 = 0$

X = Don't Care

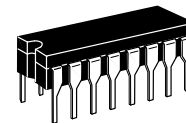

L SUFFIX
CERAMIC
CASE 620

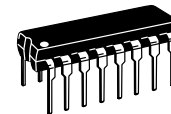

P SUFFIX
PLASTIC
CASE 648



DW SUFFIX
SOIC
CASE 751G

ORDERING INFORMATION

MC14XXXBCP Plastic
MC14XXXBCL Ceramic
MC14XXXBDW SOIC

$T_A = - 55^\circ$ to 125°C for all packages.

BLOCK DIAGRAM

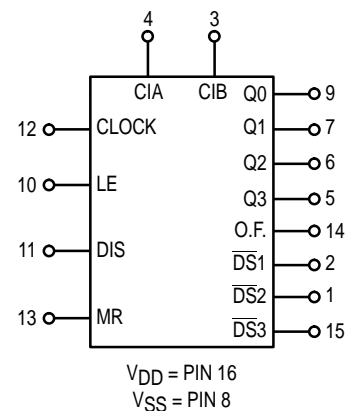

This device contains protection circuitry to guard against damage due to high static voltages or electric fields. However, precautions must be taken to avoid applications of any voltage higher than maximum rated voltages to this high-impedance circuit. For proper operation, V_{in} and V_{out} should be constrained to the range $V_{SS} \leq (V_{in} \text{ or } V_{out}) \leq V_{DD}$. Unused inputs must always be tied to an appropriate logic voltage level (e.g., either V_{SS} or V_{DD}). Unused outputs must be left open.

ELECTRICAL CHARACTERISTICS (Voltages Referenced to V_{SS})

Characteristic	Symbol	V _{DD} Vdc	- 55°C		25°C			125°C		Unit		
			Min	Max	Min	Typ #	Max	Min	Max			
Output Voltage V _{in} = V _{DD} or 0 V _{in} = 0 or V _{DD}	"0" Level V _{OL}	5.0	—	0.05	—	0	0.05	—	0.05	Vdc		
		10	—	0.05	—	0	0.05	—	0.05			
		15	—	0.05	—	0	0.05	—	0.05			
	"1" Level V _{OH}	5.0	4.95	—	4.95	5.0	—	4.95	—		Vdc	
		10	9.95	—	9.95	10	—	9.95	—			
		15	14.95	—	14.95	15	—	14.95	—			
Input Voltage "0" Level (V _O = 4.5 or 0.5 Vdc) (V _O = 9.0 or 1.0 Vdc) (V _O = 13.5 or 1.5 Vdc) "1" Level (V _O = 0.5 or 4.5 Vdc) (V _O = 1.0 or 9.0 Vdc) (V _O = 1.5 or 13.5 Vdc)	V _{IL}	5.0	—	1.5	—	2.25	1.5	—	1.5	Vdc		
		10	—	3.0	—	4.50	3.0	—	3.0			
		15	—	4.0	—	6.75	4.0	—	4.0			
	V _{IH}	5.0	3.5	—	3.5	2.75	—	3.5	—		Vdc	
		10	7.0	—	7.0	5.50	—	7.0	—			
		15	11	—	11	8.25	—	11	—			
Output Drive Current (V _{OH} = 4.6 Vdc) (V _{OH} = 9.5 Vdc) (V _{OH} = 13.5 Vdc) (V _{OH} = 4.6 Vdc) (V _{OH} = 9.5 Vdc) (V _{OH} = 13.5 Vdc) (V _{OL} = 0.4 Vdc) (V _{OL} = 0.5 Vdc) (V _{OL} = 1.5 Vdc) (V _{OL} = 0.4 Vdc) (V _{OL} = 0.5 Vdc) (V _{OL} = 1.5 Vdc)	Source — Pin 3	I _{OH}	5.0	-0.25	—	-0.2	-0.36	—	0.14	—		mAdc
			10	-0.62	—	-0.5	-0.9	—	0.35	—		
			15	-1.8	—	-1.5	-3.5	—	1.1	—		
		Source — Other Outputs	5.0	-0.64	—	-0.51	-0.88	—	-0.36	—	mAdc	
			10	-1.6	—	-1.3	-2.25	—	-0.9	—		
			15	-4.2	—	-3.4	-8.8	—	-2.4	—		
	Sink — Pin 3	I _{OL}	5.0	0.5	—	0.4	0.88	—	0.28	—		mAdc
			10	1.1	—	0.9	2.25	—	0.65	—		
			15	1.8	—	1.5	8.8	—	1.20	—		
	Sink — Other Outputs	5.0	3.0	—	2.5	4.0	—	1.6	—	mAdc		
		10	6.0	—	5.0	8.0	—	3.5	—			
		15	18	—	15	20	—	10	—			
Input Current	I _{in}	15	—	±0.1	—	±0.00001	±0.1	—	±1.0		μAdc	
Input Capacitance (V _{in} = 0)	C _{in}	—	—	—	—	5.0	7.5	—	—		pF	
Quiescent Current (Per Package) MR = V _{DD}	I _{DD}	5.0	—	5.0	—	0.010	5.0	—	150		μAdc	
		10	—	10	—	0.020	10	—	300			
		15	—	20	—	0.030	20	—	600			
Total Supply Current**† (Dynamic plus Quiescent, Per Package) (C _L = 50 pF on all outputs, all buffers switching)	I _T	5.0	I _T = (0.35 μA/kHz) f + I _{DD} I _T = (0.85 μA/kHz) f + I _{DD} I _T = (1.50 μA/kHz) f + I _{DD}							μAdc		

#Data labelled "Typ" is not to be used for design purposes but is intended as an indication of the IC's potential performance.

**The formulas given are for the typical characteristics only at 25°C.

†To calculate total supply current at loads other than 50 pF:

$$I_T(C_L) = I_T(50 \text{ pF}) + (C_L - 50) Vfk$$

where: I_T is in μA (per package), C_L in pF, V = (V_{DD} - V_{SS}) in volts, f in kHz is input frequency, and k = 0.004.

SWITCHING CHARACTERISTICS ($C_L = 50 \text{ pF}$, $T_A = 25^\circ\text{C}$)

Characteristic	Figure	Symbol	V _{DD}	Min	Typ #	Max	Unit
Output Rise and Fall Time $t_{TLH}, t_{THL} = (1.5 \text{ ns/pF}) C_L + 25 \text{ ns}$ $t_{TLH}, t_{THL} = (0.75 \text{ ns/pF}) C_L + 12.5 \text{ ns}$ $t_{TLH}, t_{THL} = (0.55 \text{ ns/pF}) C_L + 9.5 \text{ ns}$	2a	$t_{TLH},$ t_{THL}	5.0 10 15	— — —	100 50 40	200 100 80	ns
Clock to BCD Out	2a	$t_{PLH},$ t_{PHL}	5.0 10 15	— — —	900 500 200	1800 1000 400	ns
Clock to Overflow	2a	t_{PHL}	5.0 10 15	— — —	600 400 200	1200 800 400	ns
Reset to BCD Out	2b	t_{PHL}	5.0 10 15	— — —	900 500 300	1800 1000 600	ns
Clock to Latch Enable Setup Time Master Reset to Latch Enable Setup Time	2b	t_{su}	5.0 10 15	600 400 200	300 200 100	— — —	ns
Removal Time Latch Enable to Clock	2b	t_{rem}	5.0 10 15	- 80 - 10 0	- 200 - 70 - 50	— — —	ns
Clock Pulse Width	2a	$t_{WH}(cl)$	5.0 10 15	550 200 150	275 100 75	— — —	ns
Reset Pulse Width	2b	$t_{WH}(R)$	5.0 10 15	1200 600 450	600 300 225	— — —	ns
Reset Removal Time	—	t_{rem}	5.0 10 15	- 80 0 20	- 180 - 50 - 30	— — —	ns
Input Clock Frequency	2a	f_{cl}	5.0 10 15	— — —	1.5 5.0 7.0	0.9 2.5 3.5	MHz
Input Clock Rise Time	2b	t_{TLH}	5.0 10 15	No Limit			ns
Disable, MR, Latch Enable Rise and Fall Times	—	$t_{TLH},$ t_{THL}	5.0 10 15	— — —	— — —	15 5.0 4.0	μs
Scan Oscillator Frequency (C1 measured in μF)	1	f_{osc}	5.0 10 15	— — —	1.5/C1 4.2/C1 7.0/C1	— — —	Hz

* The formulas given are for the typical characteristics only at 25°C.

#Data labelled "Typ" is not to be used for design purposes but is intended as an indication of the IC's potential performance.

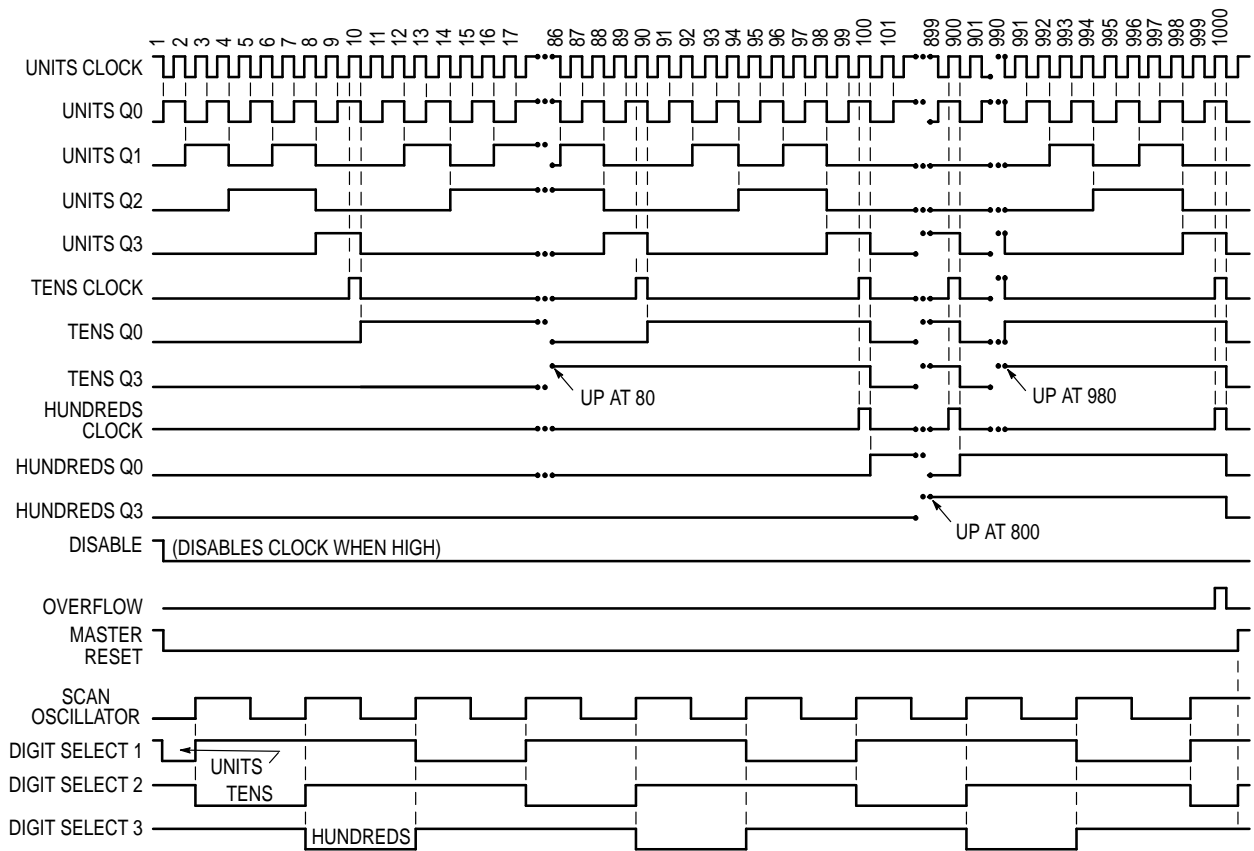

Figure 1.3-Digit Counter Timing Diagram (Reference Figure 3)

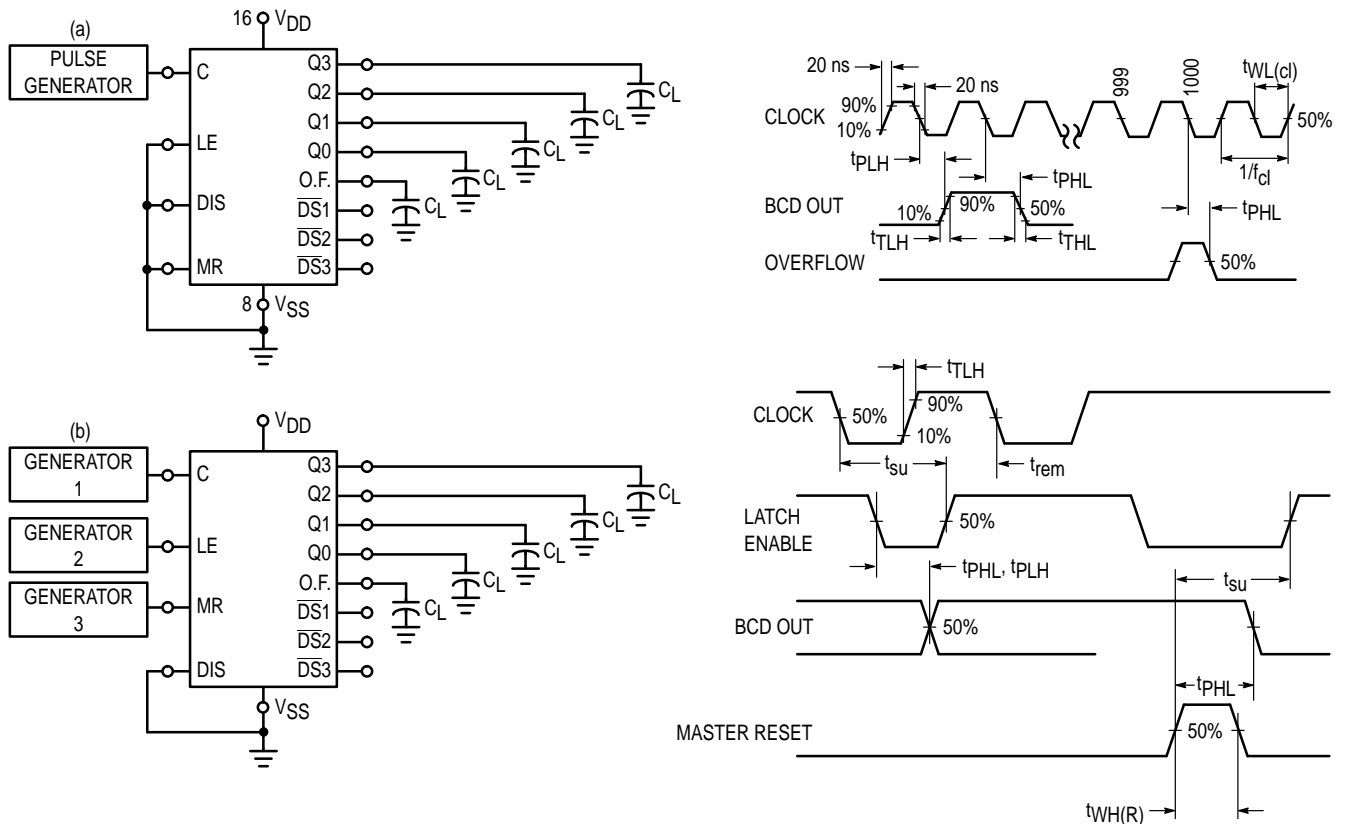

Figure 2. Switching Time Test Circuits and Waveforms

OPERATING CHARACTERISTICS

The MC14553B three-digit counter, shown in Figure 3, consists of three negative edge-triggered BCD counters which are cascaded in a synchronous fashion. A quad latch at the output of each of the three BCD counters permits storage of any given count. The three sets of BCD outputs (active high), after going through the latches, are time division multiplexed, providing one BCD number or digit at a time. Digit select outputs (active low) are provided for display control. All outputs are TTL compatible.

An on-chip oscillator provides the low frequency scanning clock which drives the multiplexer output selector. The frequency of the oscillator can be controlled externally by a capacitor between pins 3 and 4, or it can be overridden and driven with an external clock at pin 4. Multiple devices can be cascaded using the overflow output, which provides one

pulse for every 1000 counts.

The Master Reset input, when taken high, initializes the three BCD counters and the multiplexer scanning circuit. While Master Reset is high the digit scanner is set to digit one; but all three digit select outputs are disabled to prolong display life, and the scan oscillator is inhibited. The Disable input, when high, prevents the input clock from reaching the counters, while still retaining the last count. A pulse shaping circuit at the clock input permits the counters to continue operating on input pulses with very slow rise times. Information present in the counters when the latch input goes high, will be stored in the latches and will be retained while the latch input is high, independent of other inputs. Information can be recovered from the latches after the counters have been reset if Latch Enable remains high during the entire reset cycle.

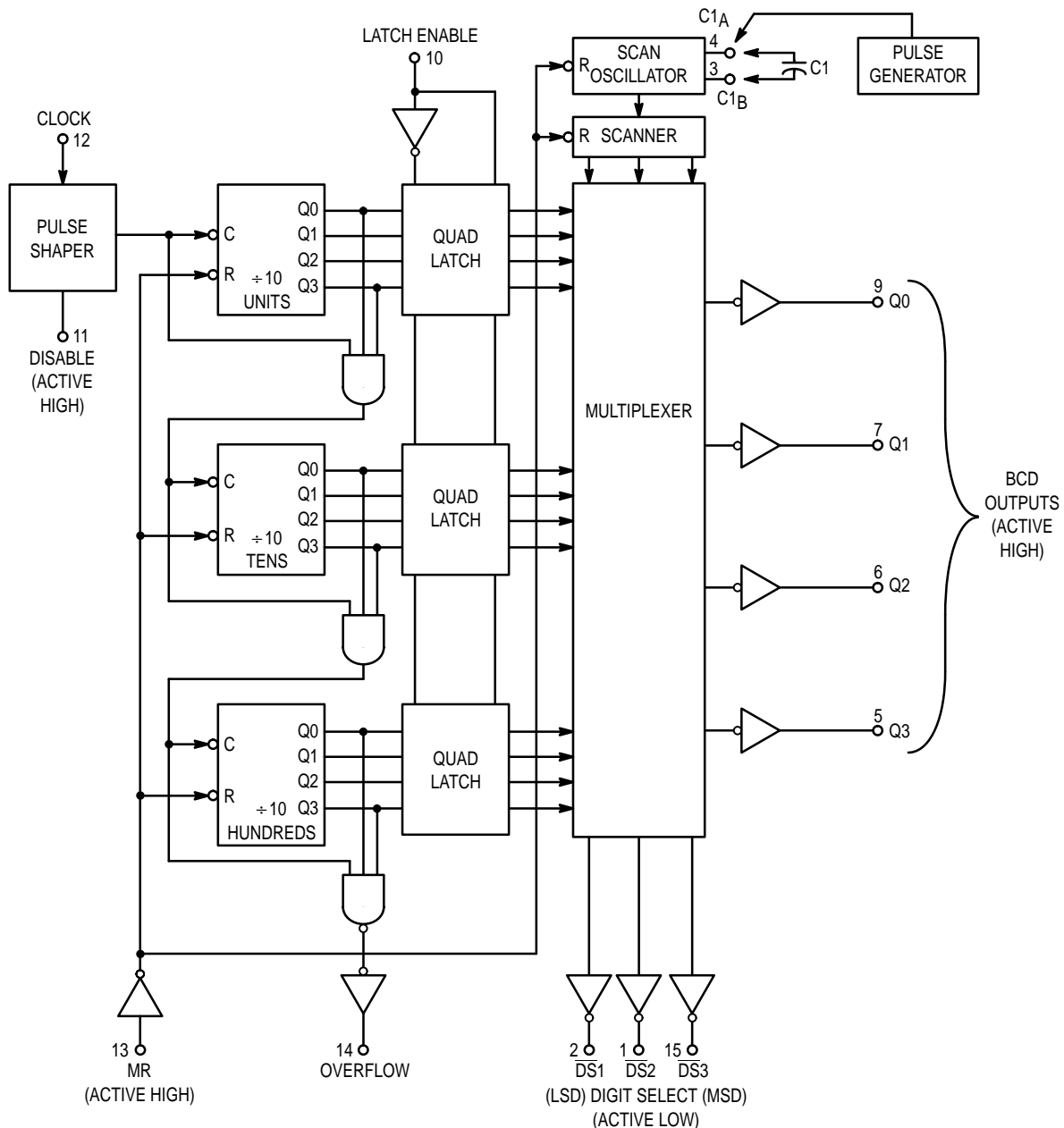

Figure 3. Expanded Block Diagram

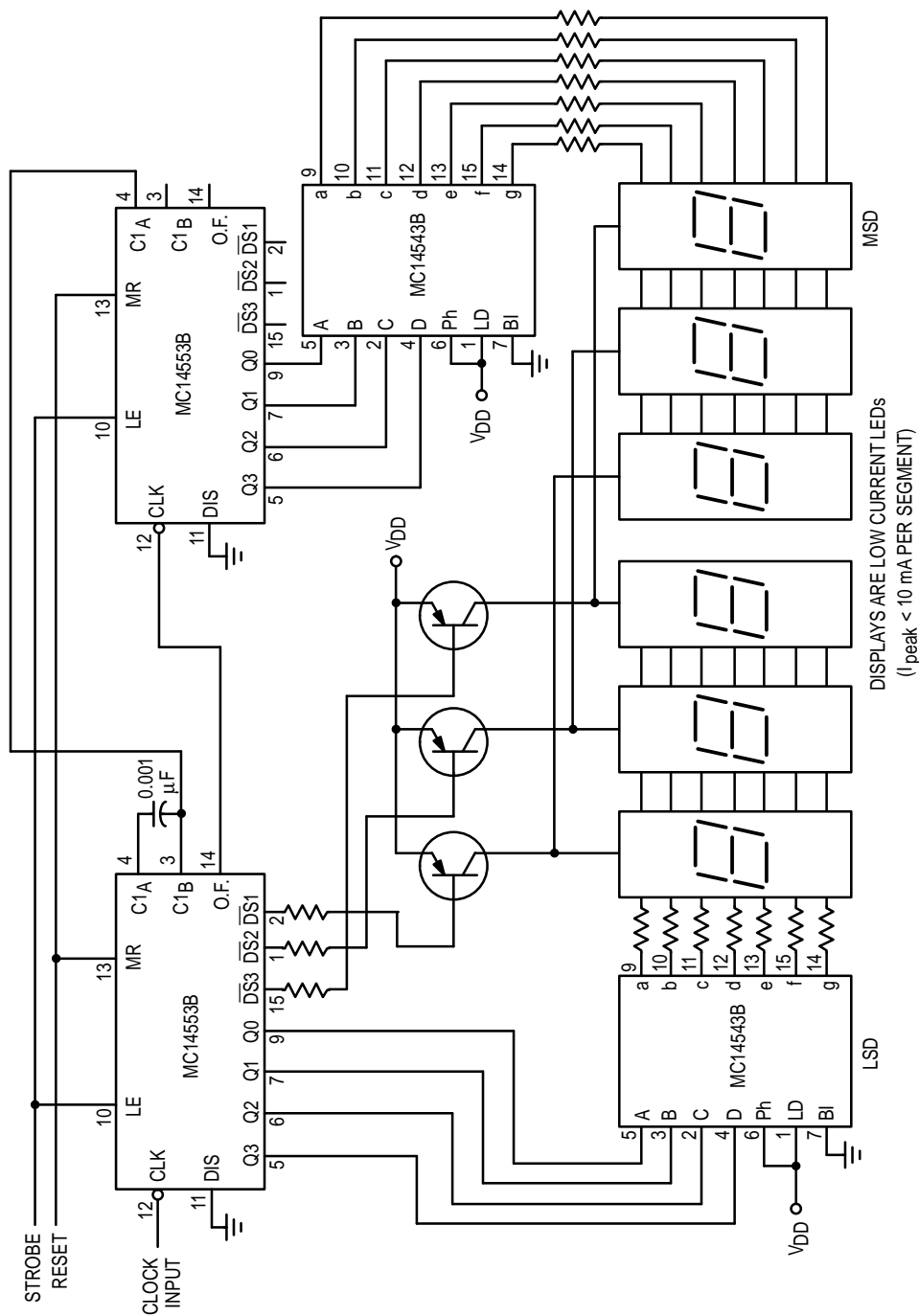
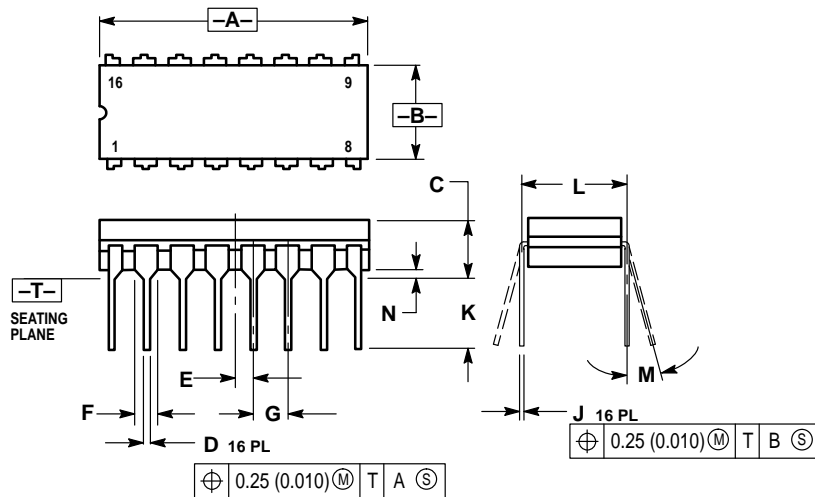

Figure 4. Six-Digit Display

OUTLINE DIMENSIONS

L SUFFIX CERAMIC DIP PACKAGE CASE 620-10 ISSUE V



NOTES:

1. DIMENSIONING AND TOLERANCING PER ANSI Y14.5M, 1982.
2. CONTROLLING DIMENSION: INCH.
3. DIMENSION L TO CENTER OF LEAD WHEN FORMED PARALLEL.
4. DIMENSION F MAY NARROW TO 0.76 (0.030) WHERE THE LEAD ENTERS THE CERAMIC BODY.

DIM	INCHES		MILLIMETERS	
	MIN	MAX	MIN	MAX
A	0.750	0.785	19.05	19.93
B	0.240	0.295	6.10	7.49
C	—	0.200	—	5.08
D	0.015	0.020	0.39	0.50
E	0.050 BSC		1.27 BSC	
F	0.055	0.065	1.40	1.65
G	0.100 BSC		2.54 BSC	
H	0.008	0.015	0.21	0.38
K	0.125	0.170	3.18	4.31
L	0.300 BSC		7.62 BSC	
M	0°	15°	0°	15°
N	0.020	0.040	0.51	1.01

P SUFFIX PLASTIC DIP PACKAGE CASE 648-08 ISSUE R

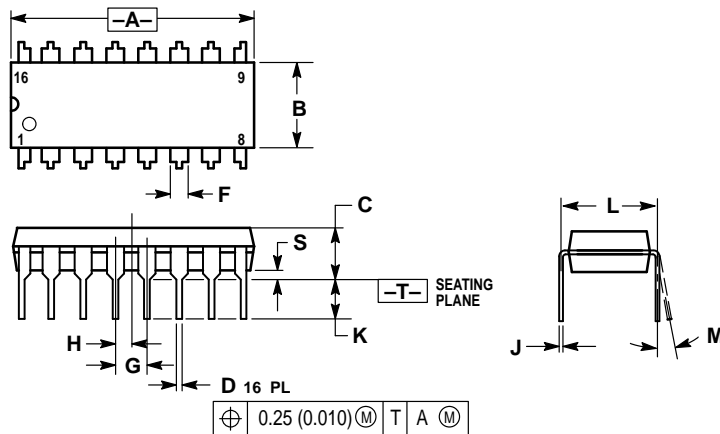

NOTES:

1. DIMENSIONING AND TOLERANCING PER ANSI Y14.5M, 1982.
2. CONTROLLING DIMENSION: INCH.
3. DIMENSION L TO CENTER OF LEADS WHEN FORMED PARALLEL.
4. DIMENSION B DOES NOT INCLUDE MOLD FLASH.
5. ROUNDED CORNERS OPTIONAL.

DIM	INCHES		MILLIMETERS	
	MIN	MAX	MIN	MAX
A	0.740	0.770	18.80	19.55
B	0.250	0.270	6.35	6.85
C	0.145	0.175	3.69	4.44
D	0.015	0.021	0.39	0.53
F	0.040	0.70	1.02	1.77
G	0.100 BSC		2.54 BSC	
H	0.050 BSC		1.27 BSC	
J	0.008	0.015	0.21	0.38
K	0.110	0.130	2.80	3.30
L	0.295	0.305	7.50	7.74
M	0°	10°	0°	10°
S	0.020	0.040	0.51	1.01

OUTLINE DIMENSIONS

DW SUFFIX PLASTIC SOIC PACKAGE CASE 751G-02 ISSUE A

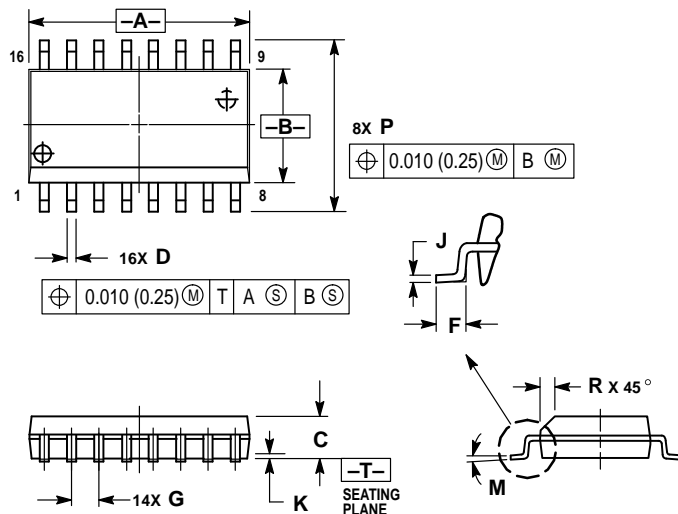

NOTES:

1. DIMENSIONING AND TOLERANCING PER ANSI Y14.5M, 1982.
2. CONTROLLING DIMENSION: MILLIMETER.
3. DIMENSIONS A AND B DO NOT INCLUDE MOLD PROTRUSION.
4. MAXIMUM MOLD PROTRUSION 0.15 (0.006) PER SIDE.
5. DIMENSION D DOES NOT INCLUDE DAMBAR PROTRUSION. ALLOWABLE DAMBAR PROTRUSION SHALL BE 0.13 (0.005) TOTAL IN EXCESS OF D DIMENSION AT MAXIMUM MATERIAL CONDITION.

DIM	MILLIMETERS		INCHES	
	MIN	MAX	MIN	MAX
A	10.15	10.45	0.400	0.411
B	7.40	7.60	0.292	0.299
C	2.35	2.65	0.093	0.104
D	0.35	0.49	0.014	0.019
F	0.50	0.90	0.020	0.035
G	1.27 BSC		0.050 BSC	
J	0.25	0.32	0.010	0.012
K	0.10	0.25	0.004	0.009
M	0°	7°	0°	7°
P	10.05	10.55	0.395	0.415
R	0.25	0.75	0.010	0.029

Motorola reserves the right to make changes without further notice to any products herein. Motorola makes no warranty, representation or guarantee regarding the suitability of its products for any particular purpose, nor does Motorola assume any liability arising out of the application or use of any product or circuit, and specifically disclaims any and all liability, including without limitation consequential or incidental damages. "Typical" parameters which may be provided in Motorola data sheets and/or specifications can and do vary in different applications and actual performance may vary over time. All operating parameters, including "Typicals" must be validated for each customer application by customer's technical experts. Motorola does not convey any license under its patent rights nor the rights of others. Motorola products are not designed, intended, or authorized for use as components in systems intended for surgical implant into the body, or other applications intended to support or sustain life, or for any other application in which the failure of the Motorola product could create a situation where personal injury or death may occur. Should Buyer purchase or use Motorola products for any such unintended or unauthorized application, Buyer shall indemnify and hold Motorola and its officers, employees, subsidiaries, affiliates, and distributors harmless against all claims, costs, damages, and expenses, and reasonable attorney fees arising out of, directly or indirectly, any claim of personal injury or death associated with such unintended or unauthorized use, even if such claim alleges that Motorola was negligent regarding the design or manufacture of the part. Motorola and are registered trademarks of Motorola, Inc. Motorola, Inc. is an Equal Opportunity/Affirmative Action Employer.

How to reach us:

USA/EUROPE/Locations Not Listed: Motorola Literature Distribution;
P.O. Box 20912; Phoenix, Arizona 85036. 1-800-441-2447 or 602-303-5454

JAPAN: Nippon Motorola Ltd.; Tatsumi-SPD-JLDC, 6F Seibu-Butsuryu-Center,
3-14-2 Tatsumi Koto-Ku, Tokyo 135, Japan. 03-81-3521-8315

MFAX: RMFAX0@email.sps.mot.com – TOUCHTONE 602-244-6609
INTERNET: http://Design-NET.com

ASIA/PACIFIC: Motorola Semiconductors H.K. Ltd.; 8B Tai Ping Industrial Park,
51 Ting Kok Road, Tai Po, N.T., Hong Kong. 852-26629298



MC14553B/D

