

**Features**

- High speed switching
- $V_{CEO(sus)}=400V$
- Suitable for Switching Regulator and Motor Control

**Ordering Information**

Type NO.	Marking	Package Code
STD13005F	STD13005	TO-220F

**Outline Dimensions**

unit : mm

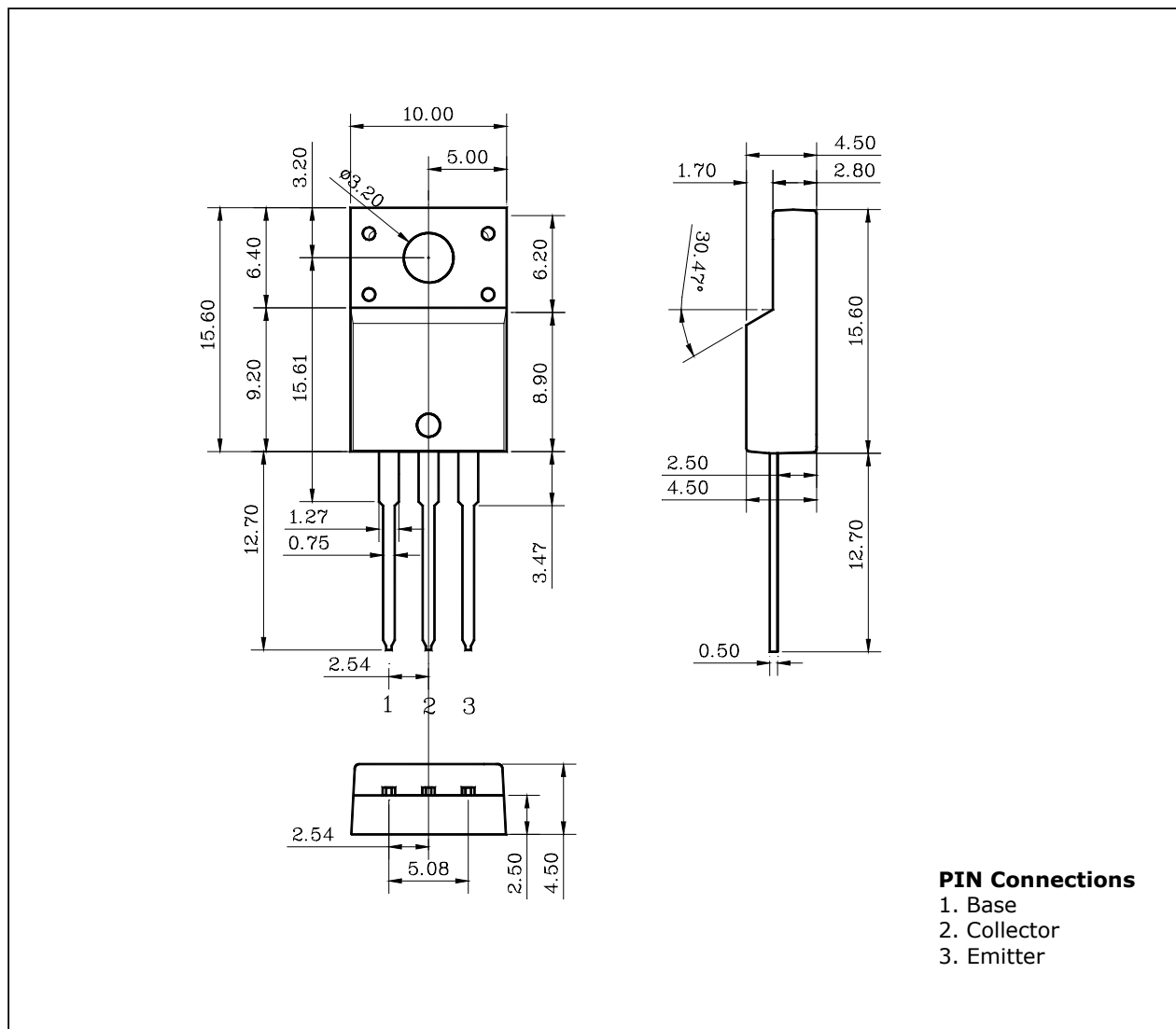

## Absolute maximum ratings

(Tc=25°C)

Characteristic	Symbol	Ratings	Unit
Collector-Base voltage	$V_{CBO}$	700	V
Collector-Emitter voltage	$V_{CEO}$	400	V
Emitter-base voltage	$V_{EBO}$	9	V
Collector current (DC)	$I_C$	4	A
Collector current (Pulse)	$I_{CM}$	8	A
Base current (DC)	$I_B$	2	A
Base current (Pulse)	$I_{BM}$	4	A
Total Power dissipation (Tc=25°C)	$P_D$	30	W
Junction temperature	$T_j$	150	°C
Storage temperature	$T_{stg}$	-55~150	°C

## Electrical Characteristics

(Tc=25°C)

Characteristic	Symbol	Test Condition	Min.	Typ.	Max.	Unit
Collector-Emitter sustaining voltage	$V_{CE(sus)}$	$I_C=10mA, I_B=0$	400	-	-	V
Collector cut-off current	$I_{CEV}$	$V_{CEV}=\text{Rated Value}$ $V_{BE(off)}=1.5V$	-	-	1	mA
Emitter cut-off current	$I_{EBO}$	$V_{EB}=9V, I_C=0$	-	-	1	mA
DC Current gain	$h_{FE}^*$	$I_C=1A, V_{CE}=5V$	10	-	60	
		$I_C=2A, V_{CE}=5V$	8	-	40	
Collector-Emitter saturation voltage	$V_{CE(sat)}^*$	$I_C=1A, I_B=0.2A$	-	-	0.5	V
		$I_C=2A, I_B=0.5A$	-	-	0.6	
		$I_C=4A, I_B=1A$	-	-	1	
Base-Emitter saturation voltage	$V_{BE(sat)}^*$	$I_C=1A, I_B=0.2A$	-	-	1.2	V
		$I_C=2A, I_B=0.5A$	-	-	1.6	
Transition frequency	$f_T$	$V_{CB}=10V, I_C=0.5A, f=1MHz$	4	-	-	MHz
Output capacitance	$C_{ob}$	$V_{CB}=10V, I_E=0, f=0.1MHz$	-	65	-	pF
Turn on Time	$t_{ON}$	$V_{CC}=125V, I_C=2A, R_L=62.5\Omega$ $I_{B1}=-I_{B2}=0.4A$	-	-	0.8	$\mu s$
Storage Time	$t_{STG}$		-	-	4	
Fall Time	$t_F$		-	-	0.9	

\* Pulse test:  $PW \leq 300 \mu s$ , Duty cycle  $\leq 2\%$  Pulse

Electrical Characteristic Curves

Fig. 1  $P_D - T_C$

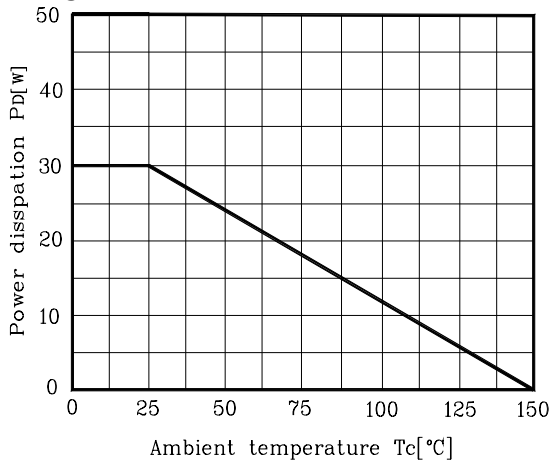

Fig. 2  $V_{BE(sat)}, V_{CE(sat)} - I_C$

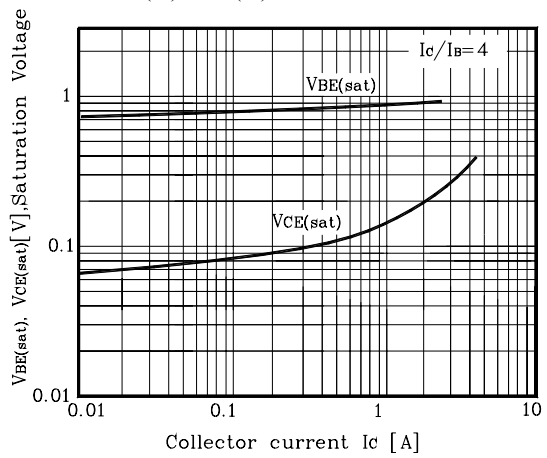

Fig. 3  $h_{FE} - I_C$

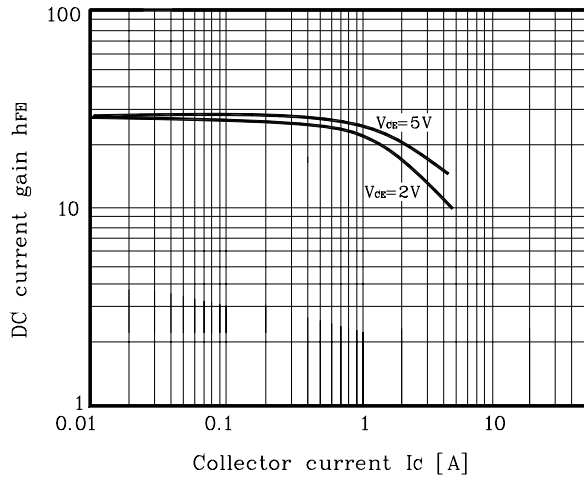

Fig. 4 Turn off time

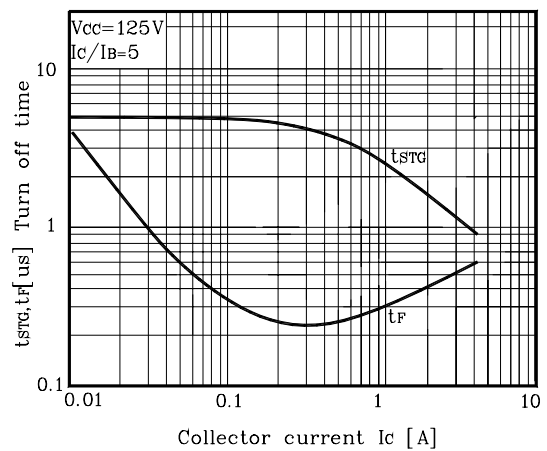

Fig. 5 Turn on time

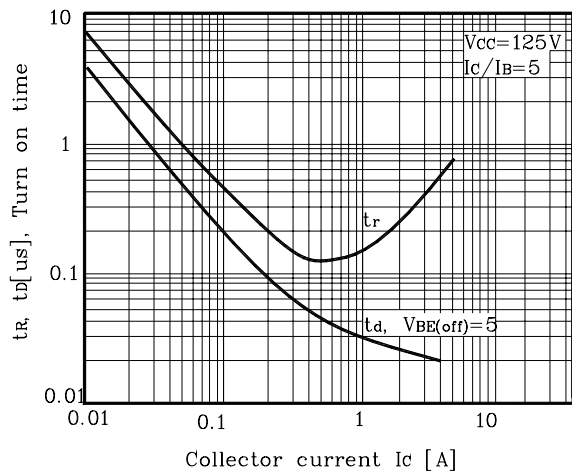

Fig. 6 Capacitance

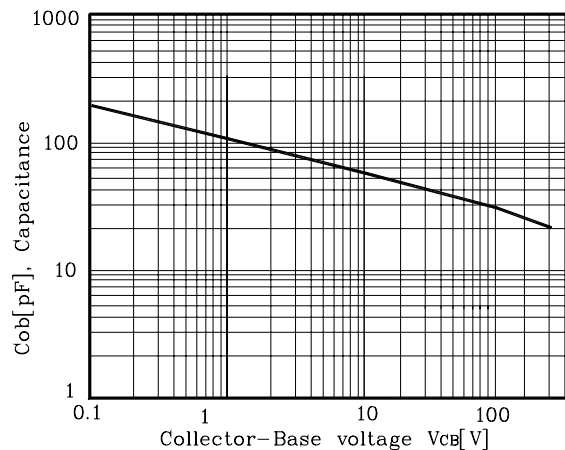

Fig. 7 Safe Operating Area

