

BUL SERIES TRANSISTORS**BUL6802**

- **FEATURES:** ■ HIGH VOLTAGE CAPABILITY ■ HIGH SPEED SWITCHING ■ WIDE SOA
- **APPLICATION:** ■ FLUORESCENT LAMP ■ ELECTRONIC BALLAST ■ ELECTRONIC TRANSFORMER

● **Absolute Maximum Ratings (Tc=25°C)** **TO-126**

PARAMETER	SYMBOL	VALUE	UNIT
Collector-Base Voltage	V_{CBO}	600	V
Collector-Emitter Voltage	V_{CEO}	400	V
Emitter- Base Voltage	V_{EBO}	9	V
Collector Current	I_C	1.2	A
Total Power Dissipation	P_C	25	W
Junction Temperature	T_j	150	°C
Storage Temperature	T_{stg}	-65-150	°C

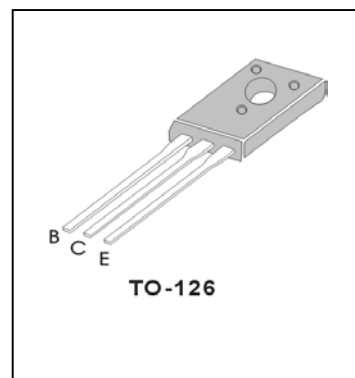

● **Electronic Characteristics (Tc=25°C)**

CHARACTERISTICS	SYMBOL	TEST CONDITION	MIN	MAX	UNIT
Collector-Base Cutoff Current	I_{CBO}	$V_{CB}=600V$		100	μA
Collector-Emitter Cutoff Current	I_{CEO}	$V_{CE}=400V, I_B=0$		250	μA
Collector-Emitter Voltage	V_{CEO}	$I_C=10mA, I_B=0$	400		V
Emitter- Base Voltage	V_{EBO}	$I_E=1mA, I_C=0$	9		V
Collector-Emitter Saturation Voltage	V_{cesat}	$I_C=0.5A, I_B=0.1A$		0.45	
		$I_C=1.0A, I_B=0.5A$		0.52	
Base-Emitter Saturation Voltage	V_{besat}	$I_C=0.5A, I_B=0.1A$		1.2	V
DC Current Gain	h_{FE}	$V_{CE}=5V, I_C=1mA$	7		
		$V_{CE}=10V, I_C=0.1A$	10	40	
		$V_{CE}=5V, I_C=1A$	5		
Storage Time	t_s	$V_{CC}=5V,$ $I_C=0.25A,$ (UI9600)	1.5	3.5	μS
Falling Time	t_f			1.0	

BUL SERIES TRANSISTORS

BUL6802

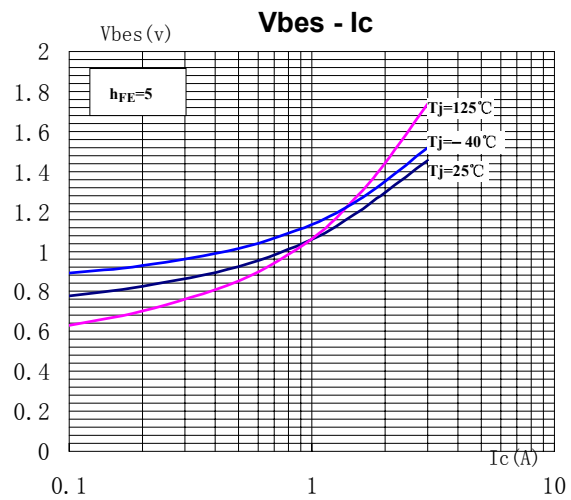
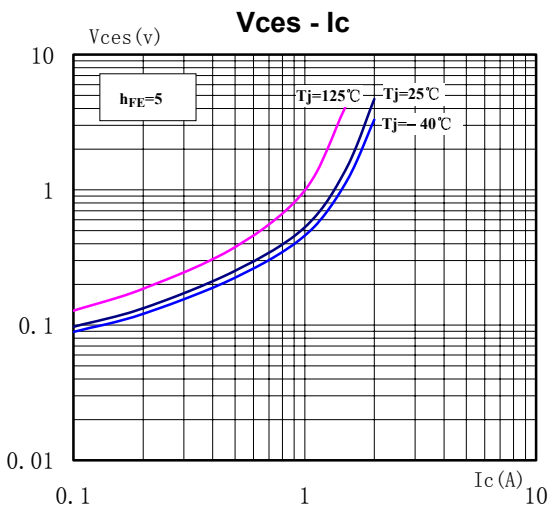
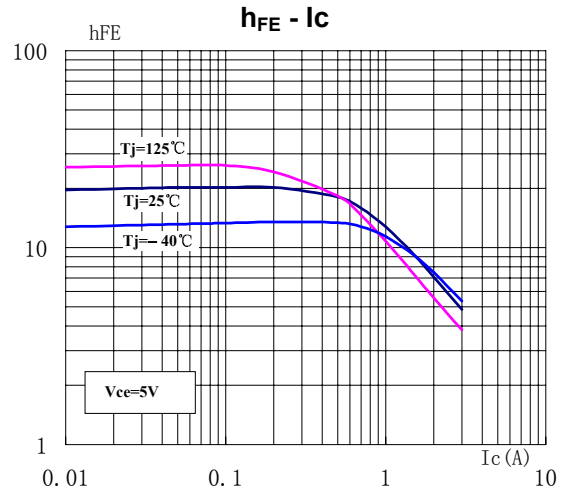
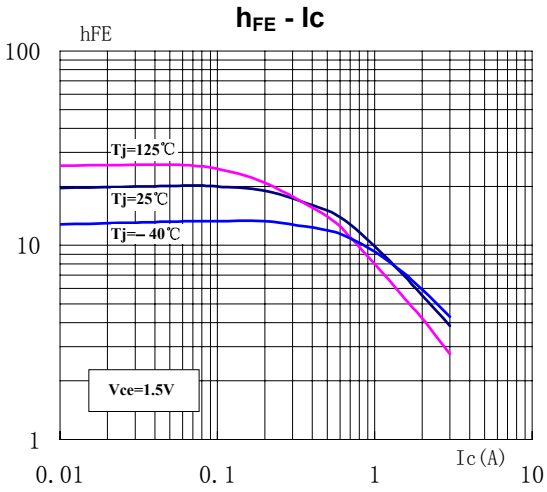
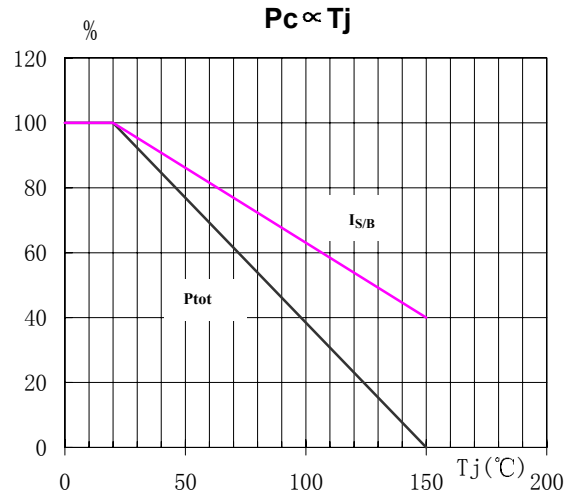
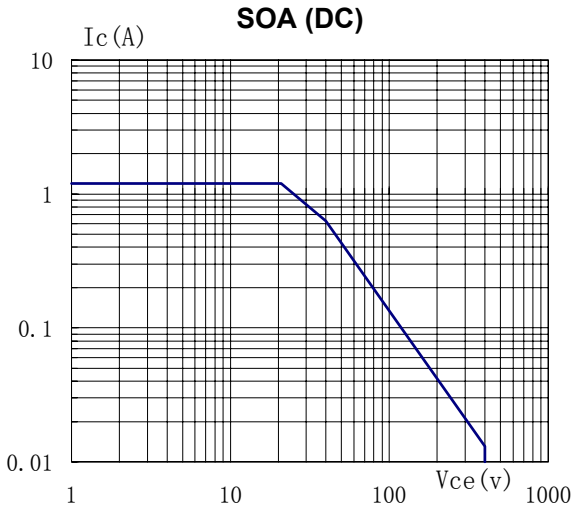

TO-126 MECHANICAL DATA

UNIT: mm

SYMBOL	min	nom	max	SYMBOL	min	nom	max
A	2.3		2.8	L	15.3		16.5
B	1.0		1.2	L1			2.54
B1	0.8		1.0	ϕP	3.0		3.2
b	0.65		0.88	$\phi P1$		5.0	
c	0.45		0.60	Q	3.6		4.4
D	10.5		11.1	Q1	0.9		1.5
E	7.2		7.8	R		0.5*	
e		2.29					

