

2SC5295

Silicon NPN epitaxial planer type

For 2 GHz band low-noise amplification

■ Features

- High transition frequency f_T
- Low collector output capacitance C_{ob}
- SS-mini type package, allowing downsizing of the equipment and automatic insertion through the tape packing.

■ Absolute Maximum Ratings $T_a = 25^\circ\text{C}$

Parameter	Symbol	Rating	Unit
Collector to base voltage	V_{CBO}	15	V
Collector to emitter voltage	V_{CEO}	10	V
Emitter to base voltage	V_{EBO}	2	V
Collector current	I_C	65	mA
Collector power dissipation	P_C	125	mW
Junction temperature	T_j	125	$^\circ\text{C}$
Storage temperature	T_{stg}	-55 to +125	$^\circ\text{C}$

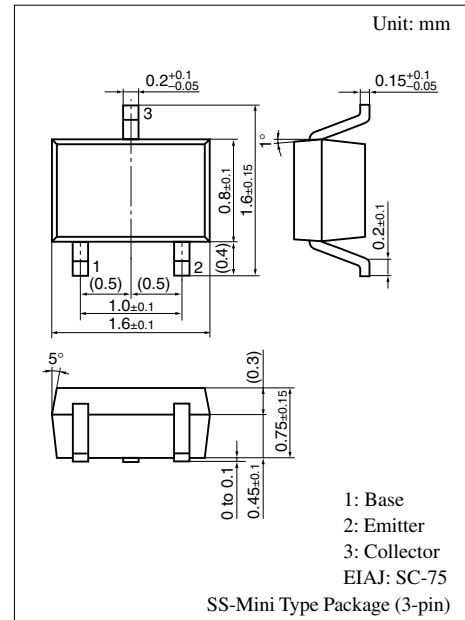

Marking Symbol: SS

■ Electrical Characteristics $T_a = 25^\circ\text{C} \pm 3^\circ\text{C}$

Parameter	Symbol	Conditions	Min	Typ	Max	Unit
Collector cutoff current	I_{CBO}	$V_{CB} = 10\text{ V}, I_E = 0$			1	μA
Emitter cutoff current	I_{EBO}	$V_{EB} = 1\text{ V}, I_C = 0$			1	μA
Forward current transfer ratio *	h_{FE}	$V_{CE} = 8\text{ V}, I_C = 20\text{ mA}$	50		300	
Transition frequency	f_T	$V_{CE} = 8\text{ V}, I_C = 15\text{ mA}, f = 1.5\text{ GHz}$	7.0	8.5		GHz
Collector output capacitance	C_{ob}	$V_{CB} = 10\text{ V}, I_E = 0, f = 1\text{ MHz}$		0.6	1.0	pF
Forward transfer gain	$ S_{21c} ^2$	$V_{CE} = 8\text{ V}, I_C = 15\text{ mA}, f = 1.5\text{ GHz}$	7	9		dB
Power gain	GUM	$V_{CE} = 8\text{ V}, I_C = 15\text{ mA}, f = 1.5\text{ GHz}$		10		dB
Noise figure	NF	$V_{CE} = 8\text{ V}, I_C = 7\text{ mA}, f = 1.5\text{ GHz}$		2.2	3.0	dB

Note) *: Rank classification

Rank	Q	R	S
h_{FE}	50 to 120	100 to 170	150 to 300