

2SC3528

Silicon PNP Triple-Diffused Planar Type

High Breakdown Voltage, High Speed Switching

■ Features

- Low collector-emitter saturation voltage ($V_{CE(sat)}$)
- Good linearity of DC current gain (h_{FE})
- High collector current (I_C)
- "Full Pack" package for simplified mounting on a heat sink with one screw

■ Absolute Maximum Ratings ($T_c=25^\circ\text{C}$)

Item	Symbol	Value	Unit
Collector-base voltage	V_{CBO}	500	V
Collector-emitter voltage	V_{CES}	500	V
	V_{CEO}	400	V
Emitter-base voltage	V_{EBO}	7	V
Peak collector current	I_{CP}	30	A
Collector current	I_C	20	A
Base current	I_B	6	A
Collector power dissipation	$T_c=25^\circ\text{C}$	125	W
	$T_a=25^\circ\text{C}$	3	
Junction temperature	T_j	150	$^\circ\text{C}$
Storage temperature	T_{stg}	-55 ~ +150	$^\circ\text{C}$

■ Package Dimensions

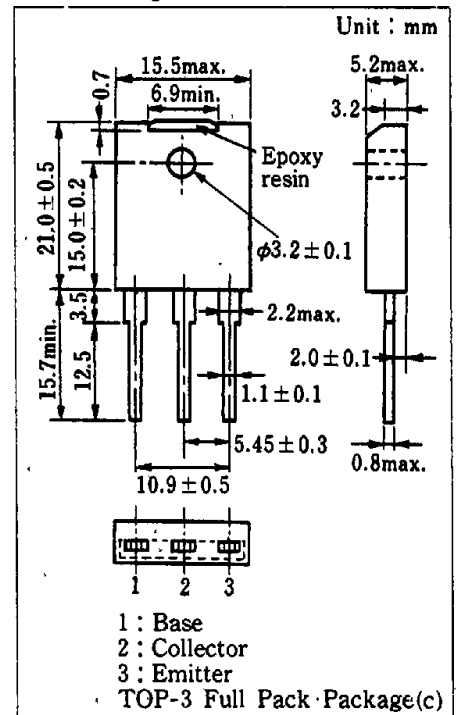

■ Electrical Characteristics ($T_c=25^\circ\text{C}$)

Item	Symbol	Condition	min.	typ.	max.	Unit
Collector cutoff current	I_{CBO}	$V_{CB}=500\text{ V}, I_E=0$			100	μA
Emitter cutoff current	I_{EBO}	$V_{EB}=7\text{ V}, I_C=0$			100	μA
Collector-emitter voltage	$V_{CEO(sus)}^*$	$I_C=0.5\text{ A}, L=25\text{ mH}$	400			V
DC current gain	h_{FE1}	$V_{CE}=5\text{ V}, I_C=2\text{ A}$	15			
	h_{FE2}	$V_{CE}=5\text{ V}, I_C=10\text{ A}$	10			
Collector-emitter saturation voltage	$V_{CE(sat)}$	$I_C=10\text{ A}, I_B=2\text{ A}$			1	V
Base-emitter saturation voltage	$V_{BE(sat)}$	$I_C=10\text{ A}, I_B=2\text{ A}$			1.5	V
Transition frequency	f_T	$V_{CE}=10\text{ V}, I_C=1\text{ A}, f=1\text{ MHz}$		15		MHz
Turn-on time	t_{on}	$I_C=10\text{ A}$			1	μS
Storage time	t_{stg}	$I_{B1}=2.0\text{ A}, I_{B2}=-2.0\text{ A}$			2.5	μS
Collector current fall time	t_f	$V_{CC}=125\text{ V}$			1	μS

* $V_{CEO(sus)}$ Test method
50/60Hz Mercury relay

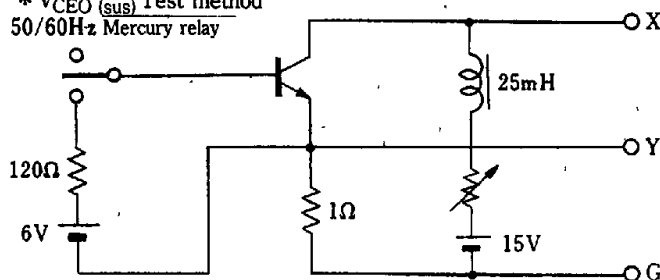

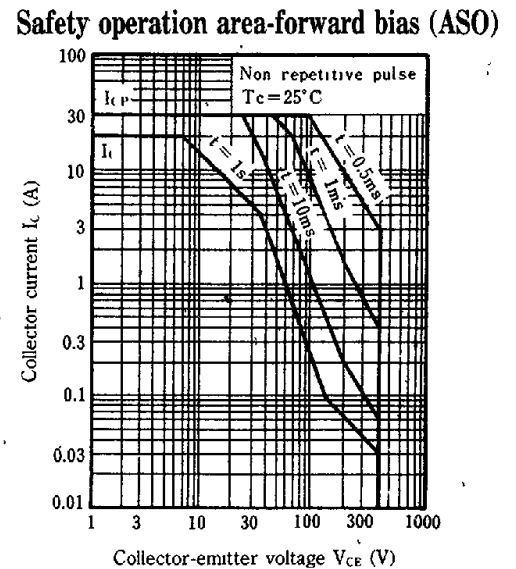
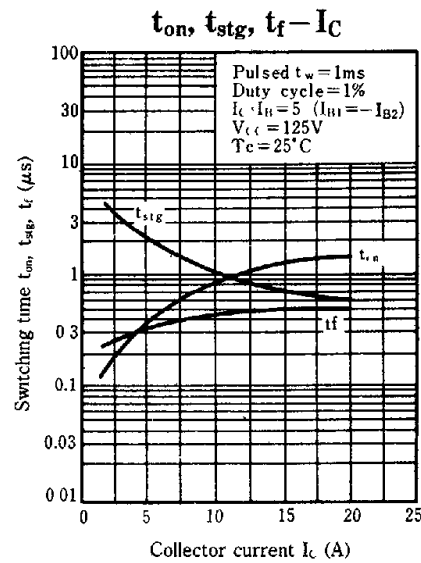
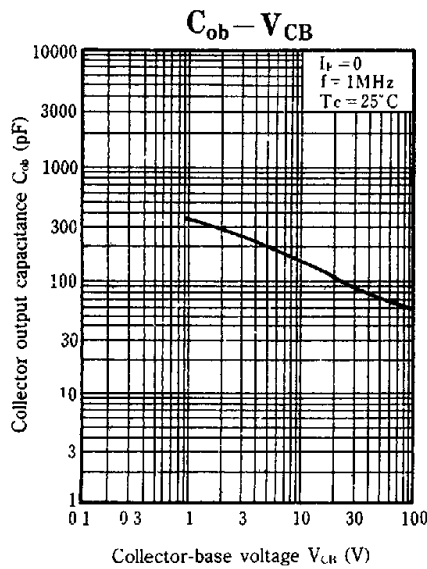
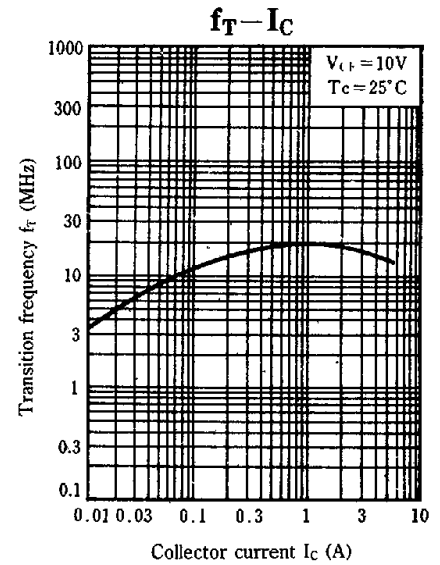
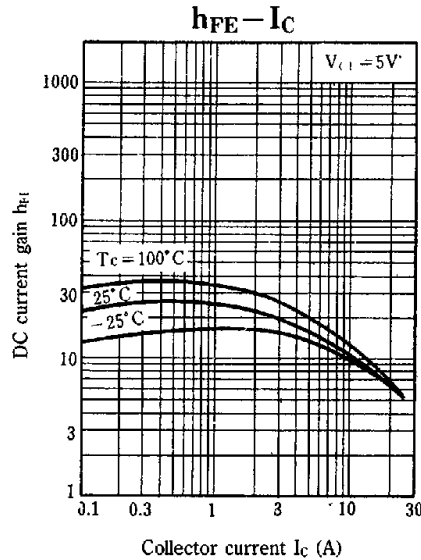
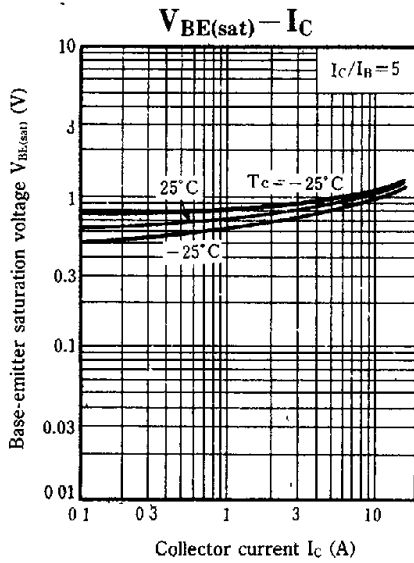
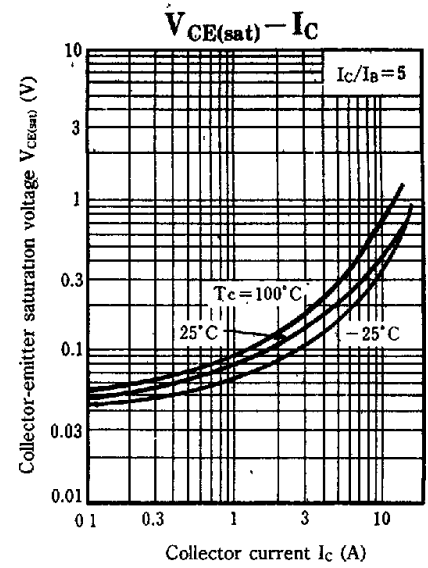
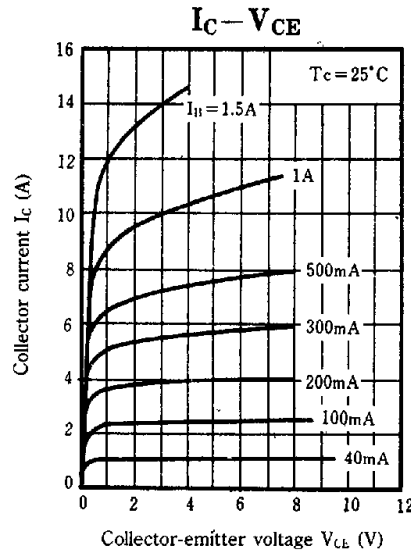
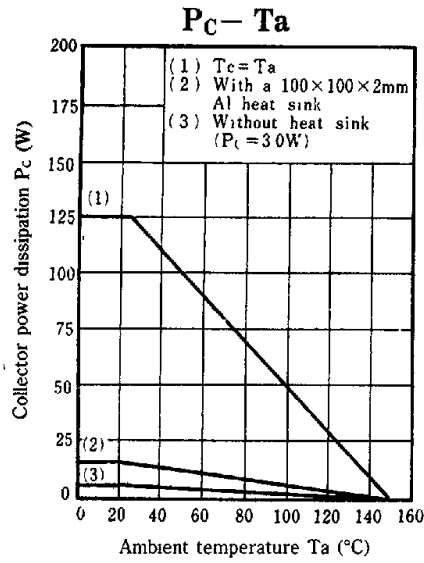

Safety operation area-reverse bias (ASO)

Measurement circuit of reverse bias ASO

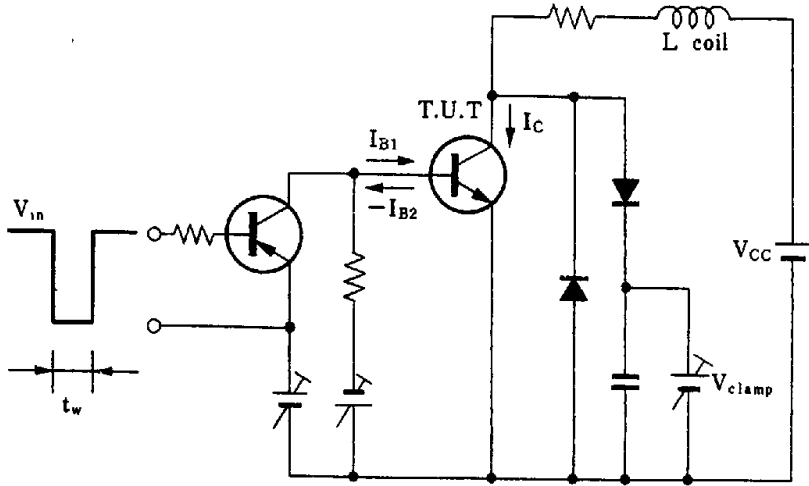
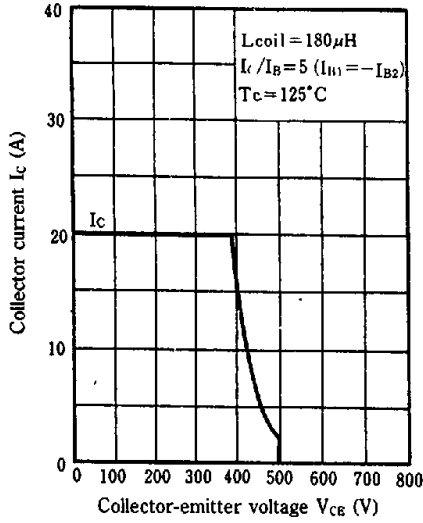

$R_{th}(t) \text{ -- } t$

