

Silicon NPN Power Transistors

2SC3220

DESCRIPTION

- With TO-247 package
- Switching power transistor
- High breakdown voltage

PINNING

PIN	DESCRIPTION
1	Base
2	Collector;connected to mounting base
3	Emitter

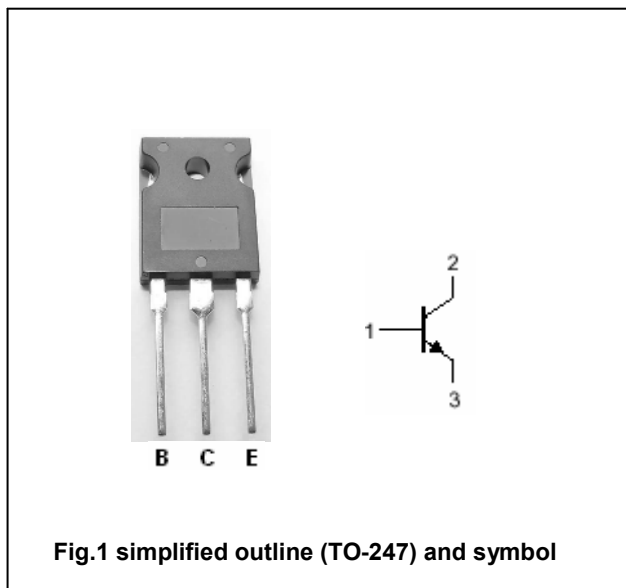

Fig.1 simplified outline (TO-247) and symbol

Absolute maximum ratings(Tc=25°C)

SYMBOL	PARAMETER	CONDITIONS	VALUE	UNIT
V <sub>CBO</sub>	Collector-base voltage	Open emitter	230	V
V <sub>CEO</sub>	Collector-emitter voltage	Open base	230	V
V <sub>EBO</sub>	Emitter-base voltage	Open collector	7	V
I <sub>C</sub>	Collector current (DC)		10	A
I <sub>B</sub>	Base current		4	A
P <sub>D</sub>	Total power dissipation	T <sub>C</sub> =25°C	80	W
T <sub>j</sub>	Junction temperature		150	°C
T <sub>stg</sub>	Storage temperature		-55~150	°C

THERMAL CHARACTERISTICS

SYMBOL	PARAMETER	MAX	UNIT
R <sub>th j-c</sub>	Thermal resistance junction to case	1.56	°C/W

## Silicon NPN Power Transistors

## 2SC3220

## CHARACTERISTICS

T<sub>j</sub>=25°C unless otherwise specified

SYMBOL	PARAMETER	CONDITIONS	MIN	TYP.	MAX	UNIT
V <sub>CE0(SUS)</sub>	Collector-emitter sustaining voltage	I <sub>C</sub> =0.1A; I <sub>B</sub> =0	230			V
V <sub>CEsat</sub>	Collector-emitter saturation voltage	I <sub>C</sub> =5A; I <sub>B</sub> =0.5A			1.0	V
V <sub>BEsat</sub>	Base-emitter saturation voltage	I <sub>C</sub> =5A; I <sub>B</sub> =0.5A			1.5	V
I <sub>CBO</sub>	Collector cut-off current	At rated voltage			0.1	mA
I <sub>CEO</sub>	Collector cut-off current					
I <sub>EBO</sub>	Emitter cut-off current	At rated voltage			0.1	mA
h <sub>FE-1</sub>	DC current gain	I <sub>C</sub> =10A; V <sub>CE</sub> =2V	15			
h <sub>FE-2</sub>	DC current gain	I <sub>C</sub> =1mA; V <sub>CE</sub> =2V	5			
f <sub>T</sub>	Transition frequency	I <sub>C</sub> =0.6A; V <sub>CE</sub> =10V		20		MHz

Silicon NPN Power Transistors

2SC3220

PACKAGE OUTLINE

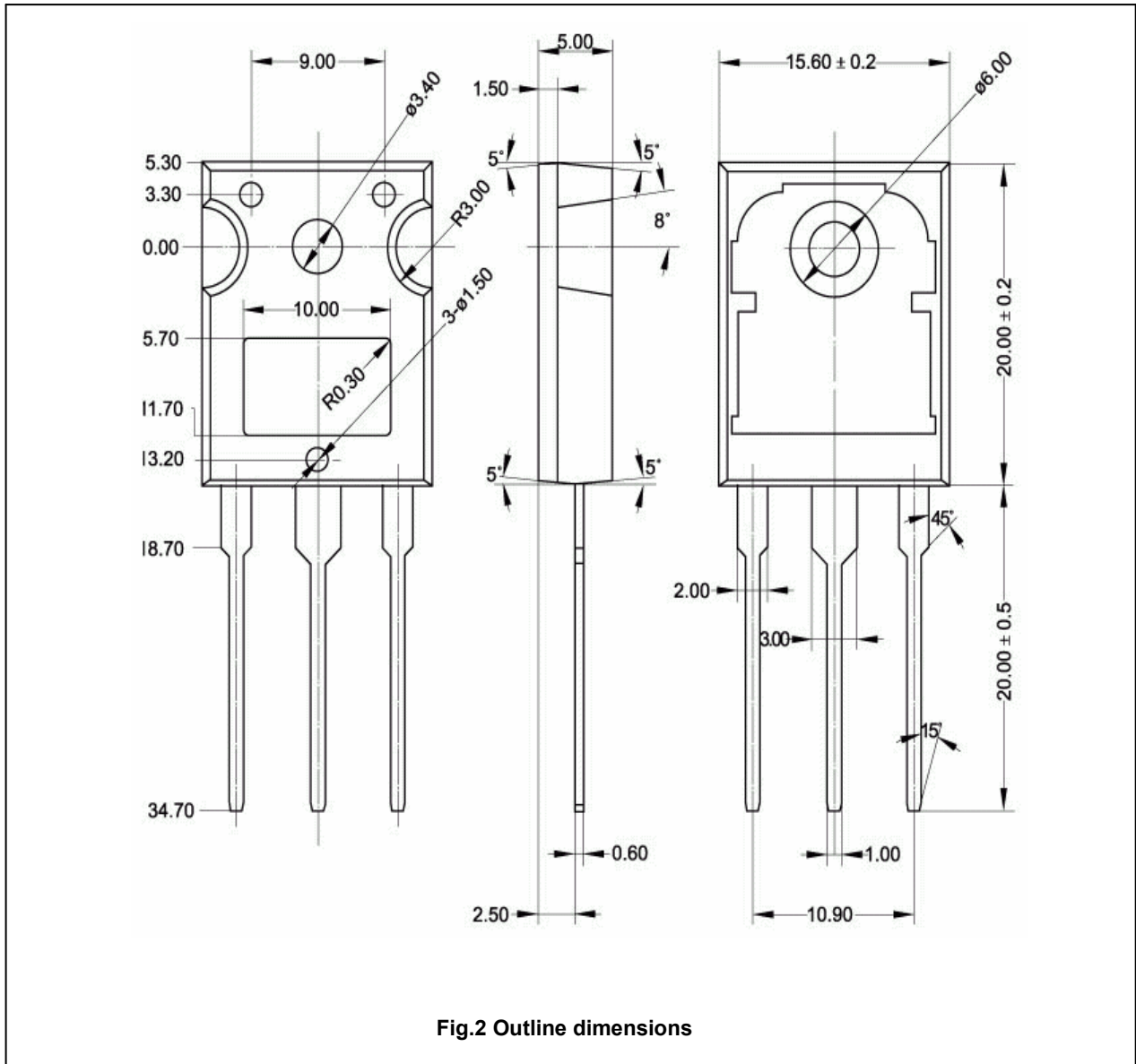

Fig.2 Outline dimensions