

Silicon NPN Power Transistors

2SC2497 2SC2497A

DESCRIPTION

- With TO-126 package
- Complement to type 2SA1096/A
- High collector to emitter voltage  $V_{CEO}$

APPLICATIONS

- For low-frequency power amplification

PINNING

PIN	DESCRIPTION
1	Emitter
2	Collector;connected to mounting base
3	Base

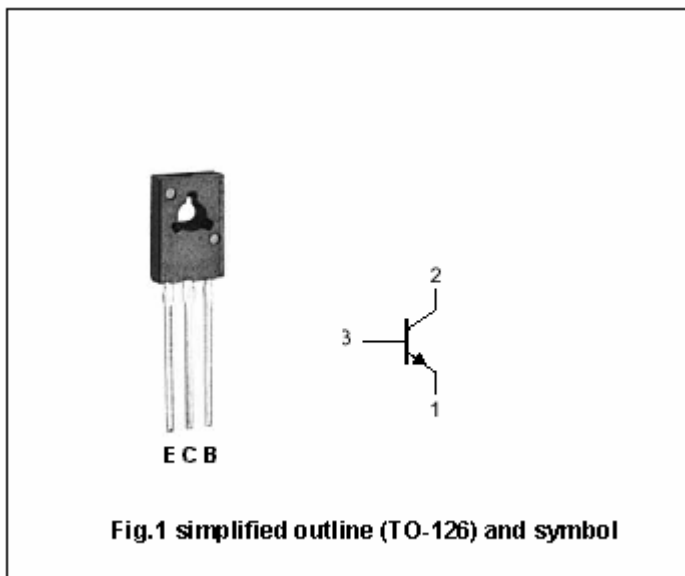

Absolute maximum ratings( $T_a=25^\circ$ )

SYMBOL	PARAMETER	CONDITIONS	VALUE	UNIT
$V_{CBO}$	Collector-base voltage	Open emitter	70	V
$V_{CEO}$	Collector- emitter voltage	2SC2497	50	V
		2SC2497A	60	
$V_{EBO}$	Emitter-base voltage	Open collector	5	V
$I_C$	Collector current		1.5	A
$I_{CM}$	Collector current-peak		3	A
$P_D$	Total power dissipation	$T_C=25^\circ$	$1.2^{*1}$	W
			$5^{*2}$	
$T_j$	Junction temperature		150	$^\circ$
$T_{stg}$	Storage temperature		$-55^\circ+150$	$^\circ$

Note) \*1: Without heat sink

\*2: With a 100 × 100 × 2 mm A1 heat sink

## Silicon NPN Power Transistors

## 2SC2497 2SC2497A

## CHARACTERISTICS

Tj=25°C unless otherwise specified

SYMBOL	PARAMETER	CONDITIONS	MIN	TYP.	MAX	UNIT
V <sub>(BR)CEO</sub>	Collector-emitter breakdown voltage	2SC2497	50			V
		2SC2497A	60			
V <sub>(BR)CBO</sub>	Collector-base breakdown voltage	I <sub>C</sub> =2mA ; I <sub>B</sub> =0	70			V
V <sub>CEsat</sub>	Collector-emitter saturation voltage	I <sub>C</sub> =1.5A ; I <sub>B</sub> =0.15A			1.0	V
V <sub>BEsat</sub>	Base-emitter saturation voltage	I <sub>C</sub> =1.5A ; I <sub>B</sub> =0.15A			1.5	V
I <sub>CEO</sub>	Collector cut-off current	V <sub>CE</sub> =10V ; I <sub>B</sub> =0			100	μA
I <sub>CBO</sub>	Collector cut-off current	V <sub>CB</sub> =20V ; I <sub>E</sub> =0			1	μA
I <sub>EBO</sub>	Emitter cut-off current	V <sub>EB</sub> =5V ; I <sub>C</sub> =0			10	μA
h <sub>FE</sub>	DC current gain	I <sub>C</sub> =1A ; V <sub>CE</sub> =5V	80		220	
C <sub>OB</sub>	Output capacitance	I <sub>E</sub> =0 ; V <sub>CB</sub> =20V, f=1MHz		35		pF
f <sub>T</sub>	Transition frequency	I <sub>E</sub> =0.5A ; V <sub>CB</sub> =5V, f=200MHz		150		MHz

◆ h<sub>FE</sub> Classifications

R	S
80-160	120-220

Silicon NPN Power Transistors

2SC2497 2SC2497A

PACKAGE OUTLINE

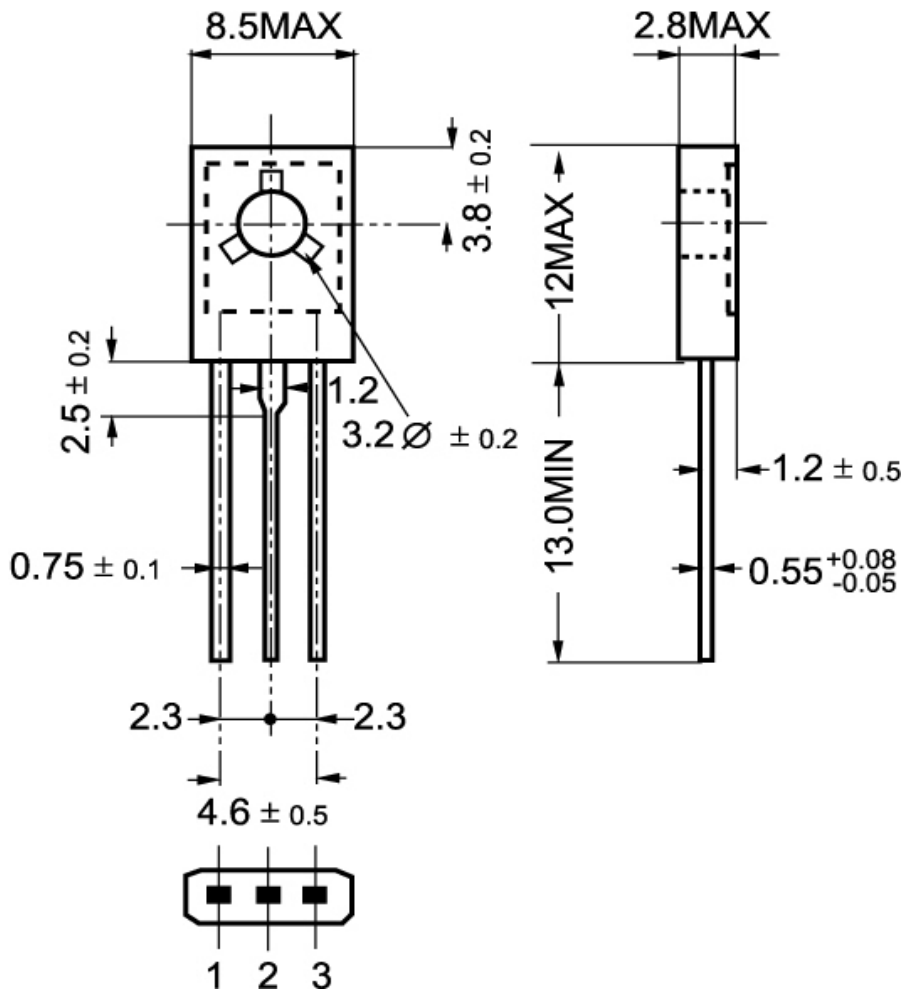

Fig.2 Outline dimensions