

## DESCRIPTION

2SC1970 is a silicon NPN epitaxial planar type transistor designed for RF power amplifiers on VHF band mobile radio applications.

## FEATURES

- High power gain:  $G_{pe} \geq 9.2\text{dB}$   
@  $V_{CC} = 13.5\text{V}$ ,  $P_O = 1\text{W}$ ,  $f = 175\text{MHz}$
- Emitter ballasted construction, gold metallization for high reliability and good performances.
- TO-220 package similarly is combinient for mounting.

## APPLICATION

0.8 to 1 watts output power amplifiers and driver in VHF band mobile radio applications.

## OUTLINE DRAWING

Dimensions in mm

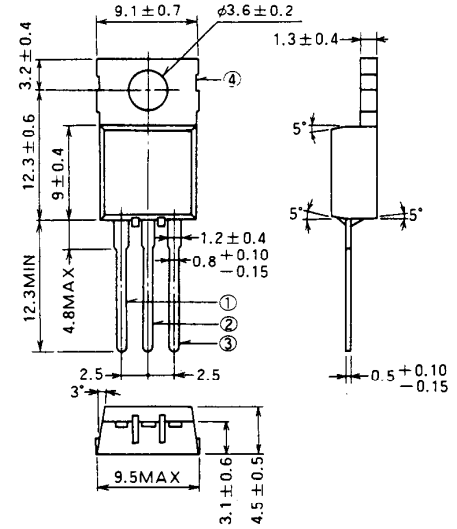

PIN :

- ① BASE
- ② COLLECTOR (FIN)
- ③ EMITTER
- ④ FIN (COLLECTOR)

T-30

## ABSOLUTE MAXIMUM RATINGS ( $T_C = 25^\circ\text{C}$ unless otherwise specified)

Symbol	Parameter	Conditions	Ratings	Unit
$V_{CBO}$	Collector to base voltage		40	V
$V_{EBO}$	Emitter to base voltage		4	V
$V_{CEO}$	Collector to emitter voltage	$R_{BE} = \infty$	17	V
$I_C$	Collector current		0.6	A
$P_C$	Collector dissipation	$T_a = 25^\circ\text{C}$	1	W
		$T_C = 25^\circ\text{C}$	5	W
$T_j$	Junction temperature		150	$^\circ\text{C}$
$T_{stg}$	Storage temperature		-55 to 150	$^\circ\text{C}$
$R_{th-a}$	Thermal resistance	Junction to ambient	125	$^\circ\text{C/W}$
		Junction to case	25	$^\circ\text{C/W}$

Note. Above parameters are guaranteed independently.

## ELECTRICAL CHARACTERISTICS ( $T_C = 25^\circ\text{C}$ unless otherwise specified)

Symbol	Parameter	Test conditions	Limits			Unit
			Min	Typ	Max	
$V_{(BR)EBO}$	Emitter to base breakdown voltage	$I_E = 1\text{mA}$ , $I_C = 0$	4			V
$V_{(BR)CBO}$	Collector to base breakdown voltage	$I_C = 5\text{mA}$ , $I_E = 0$	40			V
$V_{(BR)CEO}$	Collector to emitter breakdown voltage	$I_C = 50\text{mA}$ , $R_{BE} = \infty$	17			V
$I_{CBO}$	Collector cutoff current	$V_{CB} = 25\text{V}$ , $I_E = 0$			100	$\mu\text{A}$
$I_{EBO}$	Emitter cutoff current	$V_{EB} = 3\text{V}$ , $I_C = 0$			100	$\mu\text{A}$
$h_{FE}$	DC forward current gain*	$V_{CE} = 10\text{V}$ , $I_C = 0.1\text{A}$	10	50	180	—
$P_O$	Output power	$V_{CC} = 13.5\text{V}$ , $P_{in} = 0.12\text{W}$ , $f = 175\text{MHz}$	1	1.2		W
$\eta_C$	Collector efficiency		50	60		%

Note. \* Pulse test,  $P_W = 150\mu\text{s}$ , duty=5%.  
Above parameters, ratings, limits and conditions are subject to change.

**NPN EPITAXIAL PLANAR TYPE**

**TEST CIRCUIT**

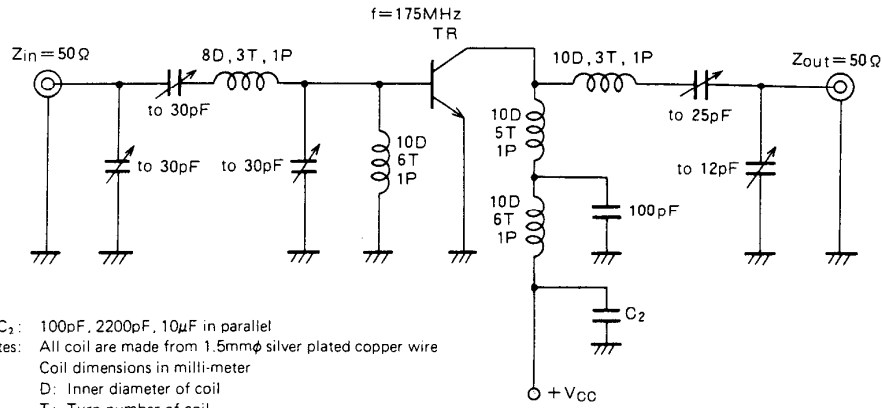

$C_2$ : 100pF, 2200pF, 10μF in parallel  
 Notes: All coil are made from 1.5mmφ silver plated copper wire  
 Coil dimensions in milli-meter  
 D: Inner diameter of coil  
 T: Turn number of coil  
 F: Pitch of coil

**TYPICAL PERFORMANCE DATA**

**COLLECTOR DISSIPATION VS. AMBIENT TEMPERATURE**

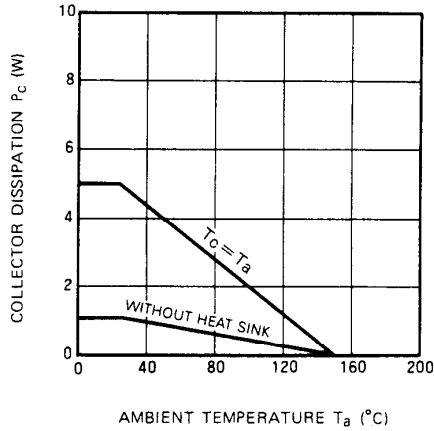

**COLLECTOR CURRENT VS. COLLECTOR TO EMITTER VOLTAGE**

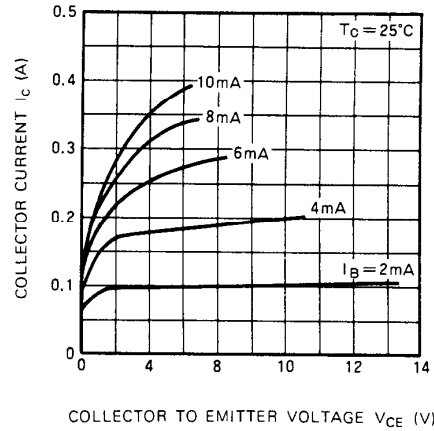

**COLLECTOR TO EMITTER BREAKDOWN VOLTAGE VS. BASE TO EMITTER RESISTANCE**

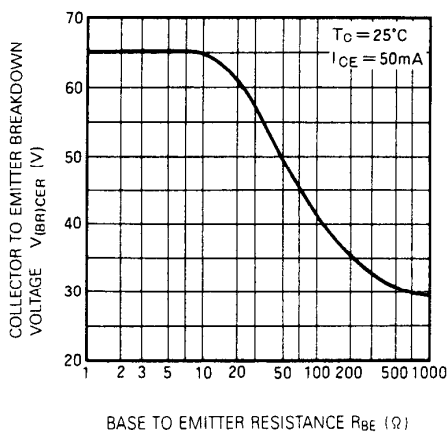

**DC CURRENT GAIN VS. COLLECTOR CURRENT**

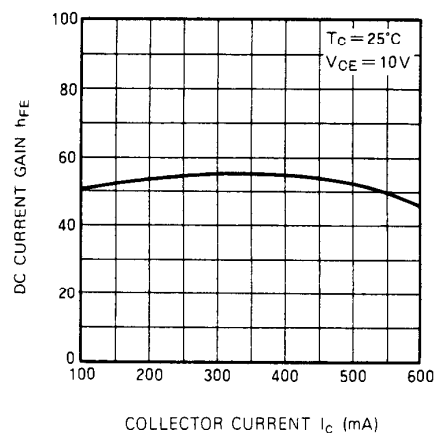

**NPN EPITAXIAL PLANAR TYPE**

**COLLECTOR OUTPUT CAPACITANCE VS. COLLECTOR TO BASE VOLTAGE**

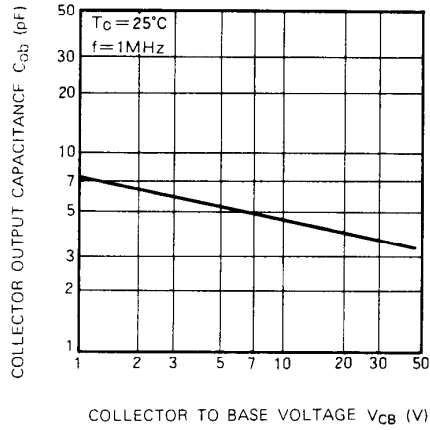

**OUTPUT POWER, COLLECTOR EFFICIENCY VS. INPUT POWER**

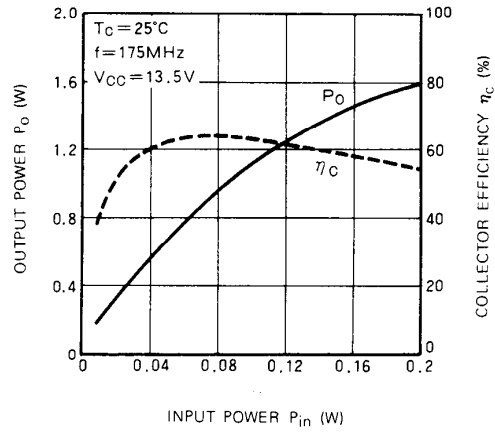

**OUTPUT POWER VS. COLLECTOR SUPPLY VOLTAGE**

