

DESCRIPTION

2SC1324 is a silicon NPN epitaxial planar type transistor designed for industrial use RF broadband amplifiers from VHF to UHF band.

FEATURES

- High power gain: $G_{pe} \geq 9\text{dB}$
@ $V_{CC} = 15\text{V}$, $I_C = 30\text{mA}$, $f = 770\text{MHz}$
- TO-12 metal sealed package with case grounded pin for high reliability and good performances.
- All electrodes excepted ground pin are isolated from the case.

APPLICATION

Broadband amplifiers from VHF to UHF band.

OUTLINE DRAWING

Dimensions in mm

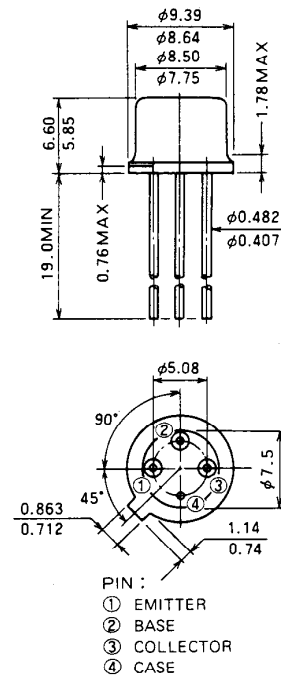

T-8

ABSOLUTE MAXIMUM RATINGS ($T_C = 25^\circ\text{C}$ unless otherwise specified)

Symbol	Parameter	Conditions	Ratings	Unit
V_{CBO}	Collector to base voltage		35	V
V_{EBO}	Emitter to base voltage		4	V
V_{CEO}	Collector to emitter voltage	$R_{BE} = \infty$	25	V
I_C	Collector current		150	mA
P_C	Collector dissipation	$T_a = 25^\circ\text{C}$	0.8	W
		$T_C = 25^\circ\text{C}$	3	W
T_J	Junction temperature		175	$^\circ\text{C}$
T_{stg}	Storage temperature		-65 to 175	$^\circ\text{C}$
R_{th-a}	Thermal resistance	Junction to ambient	187.5	$^\circ\text{C}/\text{W}$
R_{th-c}		Junction to case	50	$^\circ\text{C}/\text{W}$

Note. Above parameters are guaranteed independently.

ELECTRICAL CHARACTERISTICS ($T_C = 25^\circ\text{C}$ unless otherwise specified)

Symbol	Parameter	Test conditions	Limits			Unit
			Min	Typ	Max	
$V_{(BR)EBO}$	Emitter to base breakdown voltage	$I_E = 1\text{mA}$, $I_C = 0$	4			V
$V_{(BR)CBO}$	Collector to base breakdown voltage	$I_C = 1\text{mA}$, $I_E = 0$	35			V
$V_{(BR)CEO}$	Collector to emitter breakdown voltage	$I_C = 10\text{mA}$, $R_{BE} = \infty$	25			V
I_{CBO}	Collector cutoff current	$V_{CB} = 25\text{V}$, $I_E = 0$			50	μA
I_{EBO}	Emitter cutoff current	$V_{EB} = 3\text{V}$, $I_C = 0$			75	μA
h_{FE}	DC forward current gain *	$V_{CE} = 15\text{V}$, $I_C = 30\text{mA}$	20	70	180	—
G_{pe}	Power gain	$V_{CC} = 15\text{V}$, $f = 770\text{MHz}$, $I_C = 30\text{mA}$	9	10		dB
f_T	Transition frequency	$V_{CE} = 15\text{V}$, $I_C = 30\text{mA}$		1.7		GHz
NF	Noise figure	$V_{CC} = 15\text{V}$, $I_C = 30\text{mA}$, $f = 500\text{MHz}$, $R_G = 50\Omega$		5		dB

Note. * Pulse test, $P_W = 150\mu\text{s}$, duty=5%.
 Above parameters, ratings, limits and conditions are subject to change.

TEST CIRCUIT

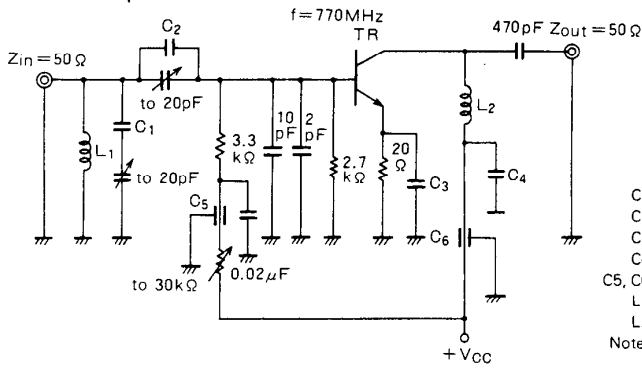

- C1: 2pF, 3pF in parallel
- C2: 3pF, 4pF in parallel
- C3: 500pF, 0.02μF in parallel
- C4: 0.05μF, 0.03μF, 0.01μF in parallel
- C5, C6: 1500pF
- L1: 4mm core, 10T, enameled wire
- L2: Width 2mm, length 20mm ribbon lead (silver plated copper plate)
- Notes: Coil dimensions in milli-meter
- T: Turn number of coil

TYPICAL PERFORMANCE DATA

COLLECTOR DISSIPATION VS. AMBIENT TEMPERATURE

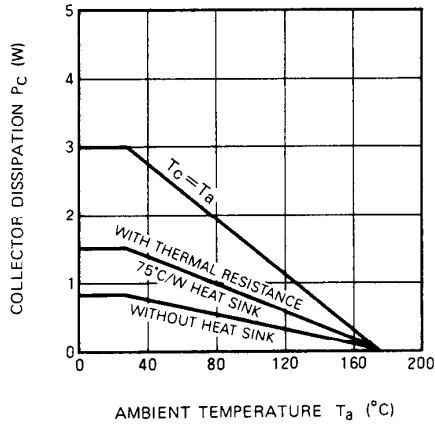

COLLECTOR CURRENT VS. COLLECTOR TO EMITTER VOLTAGE

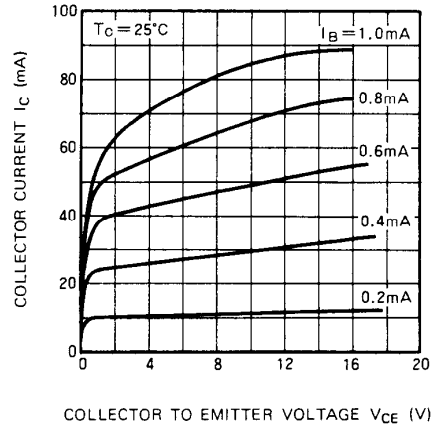

COLLECTOR TO EMITTER BREAKDOWN VOLTAGE VS. BASE TO EMITTER RESISTANCE

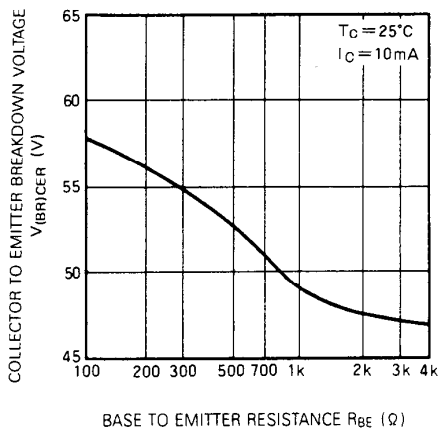

DC CURRENT GAIN VS. COLLECTOR CURRENT

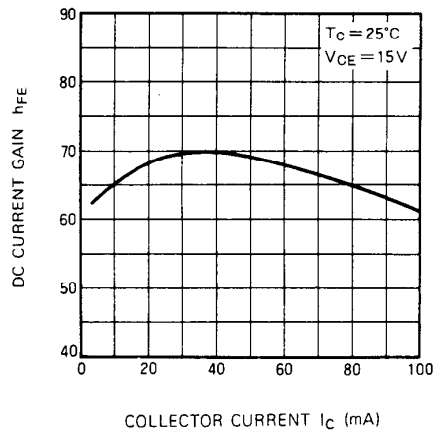

NPN EPITAXIAL PLANAR TYPE

COLLECTOR OUTPUT CAPACITANCE VS. COLLECTOR TO BASE VOLTAGE

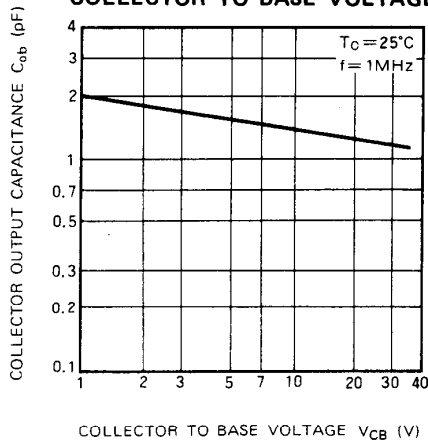

INPUT ADMITTANCE VS. FREQUENCY

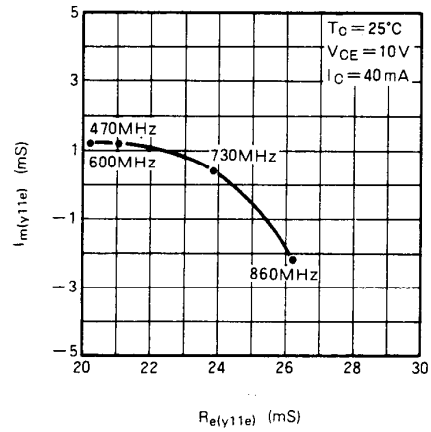

OUTPUT ADMITTANCE VS. FREQUENCY

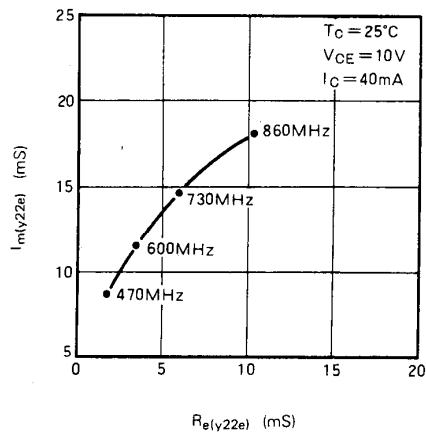

NOISE FIGURE VS. COLLECTOR CURRENT

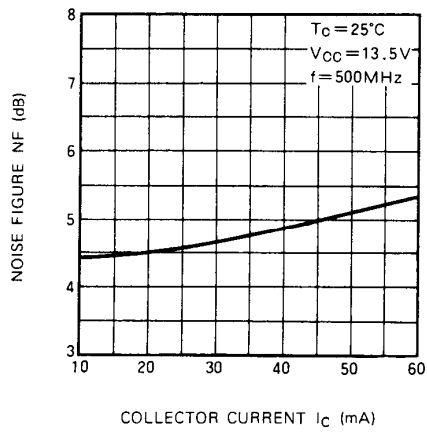

POWER GAIN VS. COLLECTOR SUPPLY VOLTAGE

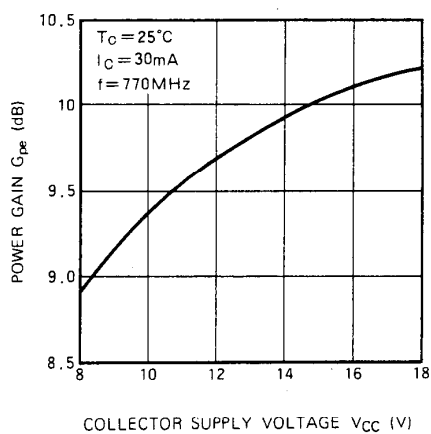

POWER GAIN VS. COLLECTOR CURRENT

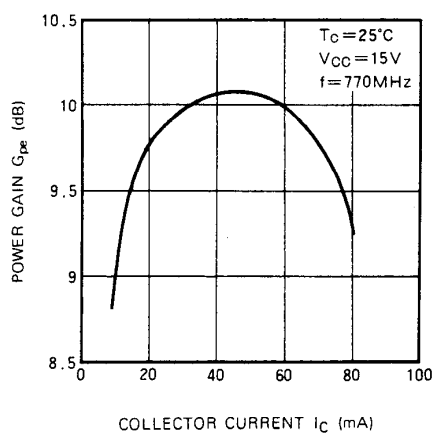

**THIRD ORDER INTERMODULATION
DISTORTION VS. OUTPUT LEVEL**

