

Low-Voltage, Single and Dual Supply, Dual 4 to 1 Multiplexer Analog Switch with Enable

The Intersil ISL43840 device is a precision, bidirectional, analog switches configured as a dual 4 channel multiplexer/demultiplexer designed to operate from a single +2V to +12V supply or from a $\pm 2V$ to $\pm 6V$ supply. The device has two enable bar pins to simultaneously open all signal paths of bank A and B.

ON resistance of 39Ω with a $\pm 5V$ supply and 125Ω with a +3.3V supply. Each switch can handle rail to rail analog signals. The off-leakage current is only .01nA at +25°C or 2.5nA at +85°C.

All digital inputs have 0.8V to 2.4V logic thresholds, ensuring TTL/CMOS logic compatibility when using a single 3.3V or +5V supply or dual $\pm 5V$ supplies.

The ISL43840 is a dual 4 to 1 multiplexer device. Table 1 summarizes the performance of this part.

TABLE 1. FEATURES AT A GLANCE

| CONFIGURATION | DUAL 4:1 MUX |
|---------------------------|---------------|
| $\pm 5V R_{ON}$ | 39Ω |
| $\pm 5V t_{ON} / t_{OFF}$ | 32ns/18ns |
| 12V R_{ON} | 32Ω |
| 12V t_{ON} / t_{OFF} | 23ns/15ns |
| 5V R_{ON} | 65Ω |
| 5V t_{ON} / t_{OFF} | 38ns/19ns |
| 3.3V R_{ON} | 125Ω |
| 3.3V t_{ON} / t_{OFF} | 70ns/32ns |
| Package | 20 Ld 4x4 QFN |

Related Literature

- Technical Brief TB363 "Guidelines for Handling and Processing Moisture Sensitive Surface Mount Devices (SMDs)"
- Application Note AN557 "Recommended Test Procedures for Analog Switches"
- Application Note AN520 "CMOS Analog Multiplexers and Switches; Specifications and Application Considerations."
- Application Note AN1034 "Analog Switch and Multiplexer Applications"

Features

- Fully Specified at 3.3V, 5V, $\pm 5V$, and 12V Supplies for 10% Tolerances
- ON Resistance (R_{ON}) Max, $V_S = \pm 4.5V$ 50Ω
- ON Resistance (R_{ON}) Max, $V_S = +3V$ 155Ω
- R_{ON} Matching Between Channels, $V_S = \pm 5V$ $<2\Omega$
- Low Charge Injection, $V_S = \pm 5V$ 1pC (Max)
- Single Supply Operation. +2V to +12V
- Dual Supply Operation $\pm 2V$ to $\pm 6V$
- Fast Switching Action ($V_S = +5V$)
 - t_{ON} 38ns
 - t_{OFF} 19ns
- Guaranteed Max Off-leakage 2.5nA
- Guaranteed Break-Before-Make
- TTL, CMOS Compatible

Applications

- Communications Systems
 - Radios
 - Telecom Infrastructure
 - ADSL, VDSL Modems
- Test Equipment
 - Medical Ultrasound
 - Magnetic Resonance Image
 - CT and PET Scanners (MRI)
 - ATE
 - Electrocardiograph
- Audio and Video Signal Routing
- Various Circuits
 - +3V/+5V DACs and ADCs
 - Sample and Hold Circuits
 - Operational Amplifier Gain Switching Networks
 - High Frequency Analog Switching
 - High Speed Multiplexing
 - Integrator Reset Circuits

Pinout

ISL43840 (QFN)
TOP VIEW

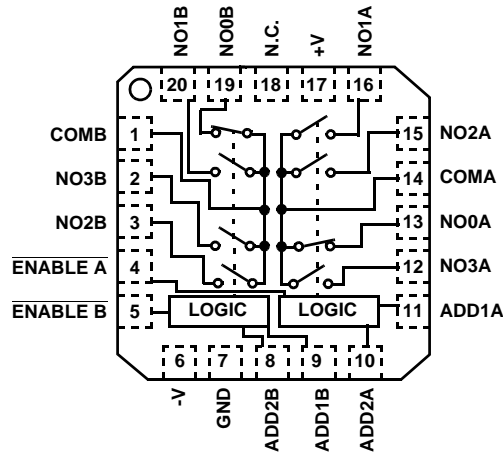

Truth Table (Note)

| ISL43840 | | | |
|----------|------|------|-----------|
| ENABLE | ADD2 | ADD1 | SWITCH ON |
| 1 | X | X | NONE |
| 0 | 0 | 0 | NO0 |
| 0 | 0 | 1 | NO1 |
| 0 | 1 | 0 | NO2 |
| 0 | 1 | 1 | NO3 |

NOTE: Applies to either A or B switch. Logic "0" ≤0.8V. Logic "1" ≥2.4V, with V+ between 2.7V and 10V. X = Don't Care.

Ordering Information

| PART NO. (BRAND) | TEMP. RANGE (°C) | PACKAGE | PKG. NO. |
|----------------------|------------------|-----------|----------|
| ISL43840IR (43840IR) | -40 to 85 | 20 Ld QFN | L20.4x4 |

Pin Descriptions

| PIN | FUNCTION |
|--------|---|
| V+ | Positive Power Supply Input |
| V- | Negative Power Supply Input. Connect to GND for Single Supply Configurations. |
| GND | Ground Connection |
| ENABLE | Digital Control Input. Connect to GND for Normal Operation. Connect to V+ to turn all switches off. |
| COM | Analog Switch Common Pin |
| NO | Analog Switch Normally Open Pin |
| NC | Analog Switch Normally Closed Pin |
| ADD | Address Input Pin |
| N.C. | No Internal Connection |

Absolute Maximum Ratings

| | |
|--|-----------------------|
| V+ to V- | -0.3 to 15V |
| V+ to GND | -0.3 to 15V |
| V- to GND | -15 to 0.3V |
| Input Voltages | |
| \overline{EN} , NO, ADD (Note 1) | -0.3 to ((V+) + 0.3V) |
| Output Voltages | |
| COM (Note 1) | -0.3 to ((V+) + 0.3V) |
| Continuous Current (Any Terminal) | ±30mA |
| Peak Current NO, NC, or COM (Pulsed 1ms, 10% Duty Cycle, Max) | ±100mA |

Thermal Information

| | |
|--|----------------------|
| Thermal Resistance (Typical, Note 2) | θ_{JA} (°C/W) |
| 20 Ld 4x4 QFN Package | 45 |
| Maximum Junction Temperature (Plastic Package) | 150°C |
| Maximum Storage Temperature Range | -65°C to 150°C |
| Maximum Lead Temperature (Soldering 10s) (Lead Tips Only) | 300°C |

Operating Conditions

| | |
|-------------------|---------------|
| Temperature Range | |
| ISL43840IR | -40°C to 85°C |

CAUTION: Stresses above those listed in "Absolute Maximum Ratings" may cause permanent damage to the device. This is a stress only rating and operation of the device at these or any other conditions above those indicated in the operational sections of this specification is not implied.

NOTES:

1. Signals on NO, COM, ADD, or \overline{EN} exceeding V+ or V- are clamped by internal diodes. Limit forward diode current to maximum current ratings.
2. θ_{JA} is measured with the component mounted on a low effective thermal conductivity test board in free air. See Tech Brief TB379 for details.

Electrical Specifications: ±5V Supply Test Conditions: $V_{SUPPLY} = \pm 4.5V$ to $\pm 5.5V$, GND = 0V, $V_{INH} = 2.4V$, $V_{INL} = 0.8V$ (Note 3), Unless Otherwise Specified

| PARAMETER | TEST CONDITIONS | TEMP (°C) | (NOTE 4) MIN | TYP | (NOTE 4) MAX | UNITS |
|--|---|-----------|--------------|-------|--------------|----------|
| ANALOG SWITCH CHARACTERISTICS | | | | | | |
| Analog Signal Range, V_{ANALOG} | | Full | V- | - | V+ | V |
| ON Resistance, R_{ON} | $V_S = \pm 4.5V$, $I_{COM} = 2mA$, $V_{NO} = 3V$, (See Figure 5) | 25 | - | 44 | 50 | Ω |
| | | Full | - | - | 80 | Ω |
| R_{ON} Matching Between Channels, ΔR_{ON} | $V_S = \pm 4.5V$, $I_{COM} = 2mA$, $V_{NO} = 3V$, (Note 5) | 25 | - | 1.3 | 4 | Ω |
| | | Full | - | - | 6 | Ω |
| R_{ON} Flatness, $R_{FLAT(ON)}$ | $V_S = \pm 4.5V$, $I_{COM} = 2mA$, $V_{NO} = \pm 3V$, 0V, (Note 6) | 25 | - | 7.5 | 9 | Ω |
| | | Full | - | - | 12 | Ω |
| NO or NC OFF Leakage Current, $I_{NO(OFF)}$ or $I_{NC(OFF)}$ | $V_S = \pm 5.5V$, $V_{COM} = \pm 4.5V$, $V_{NO} = \mp 4.5V$, (Note 7) | 25 | -0.1 | 0.002 | 0.1 | nA |
| | | Full | -2.5 | - | 2.5 | nA |
| COM OFF Leakage Current, $I_{COM(OFF)}$ | $V_S = \pm 5.5V$, $V_{COM} = \pm 4.5V$, $V_{NO} = \mp 4.5V$, (Note 7) | 25 | -0.1 | 0.002 | 0.1 | nA |
| | | Full | -2.5 | - | 2.5 | nA |
| COM ON Leakage Current, $I_{COM(ON)}$ | $V_S = \pm 5.5V$, $V_{COM} = V_{NO} = \pm 4.5V$, (Note 7) | 25 | -0.1 | 0.002 | 0.1 | nA |
| | | Full | -2.5 | - | 2.5 | nA |
| DIGITAL INPUT CHARACTERISTICS | | | | | | |
| Input Voltage High, $V_{\overline{EN}H}$, V_{ADDH} | | Full | 2.4 | - | - | V |
| Input Voltage Low, $V_{\overline{EN}L}$, V_{ADDL} | | Full | - | - | 0.8 | V |
| Input Current, $I_{\overline{EN}H}$, $I_{\overline{EN}L}$, I_{ADDH} , I_{ADDL} | $V_S = \pm 5.5V$, $V_{\overline{EN}H}$, $V_{ADD} = 0V$ or V+ | Full | -0.5 | 0.03 | 0.5 | μA |
| DYNAMIC CHARACTERISTICS | | | | | | |
| Enable Turn-ON Time, t_{ON} | $V_S = \pm 4.5V$, $V_{NO} = \pm 3V$, $R_L = 300\Omega$, $C_L = 35pF$, $V_{IN} = 0$ to 3, (See Figure 1) | 25 | - | 35 | 50 | ns |
| | | Full | - | - | 60 | ns |
| Enable Turn-OFF Time, t_{OFF} | $V_S = \pm 4.5V$, $V_{NO} = \pm 3V$, $R_L = 300\Omega$, $C_L = 35pF$, $V_{IN} = 0$ to 3, (See Figure 1) | 25 | - | 22 | 35 | ns |
| | | Full | - | - | 40 | ns |

ISL43840

Electrical Specifications: ±5V Supply Test Conditions: $V_{SUPPLY} = \pm 4.5V$ to $\pm 5.5V$, $GND = 0V$, $V_{INH} = 2.4V$, $V_{INL} = 0.8V$ (Note 3), Unless Otherwise Specified (Continued)

| PARAMETER | TEST CONDITIONS | TEMP (°C) | (NOTE 4) MIN | TYP | (NOTE 4) MAX | UNITS |
|--------------------------------------|---|-----------|--------------|------|--------------|-------|
| Address Transition Time, t_{TRANS} | $V_S = \pm 4.5V$, $V_{NO} = \pm 3V$, $R_L = 300\Omega$, $C_L = 35pF$, $V_{IN} = 0$ to 3, (See Figure 1) | 25 | - | 43 | 60 | ns |
| | | Full | - | - | 70 | ns |
| Break-Before-Make Time, t_{BBM} | $V_S = \pm 5.5V$, $V_{NO} = 3V$, $R_L = 300\Omega$, $C_L = 35pF$, $V_{IN} = 0$ to 3V, (See Figure 3) | Full | 2 | 7 | - | ns |
| Charge Injection, Q | $C_L = 1.0nF$, $V_G = 0V$, $R_G = 0\Omega$, (See Figure 2) | 25 | - | 0.3 | 1 | pC |
| NO/NC OFF Capacitance, C_{OFF} | $f = 1MHz$, $V_{NO} = V_{COM} = 0V$, (See Figure 7) | 25 | - | 3 | - | pF |
| COM OFF Capacitance, C_{OFF} | $f = 1MHz$, $V_{NO} = V_{COM} = 0V$, (See Figure 7) | 25 | - | 12 | - | pF |
| COM ON Capacitance, $C_{COM(ON)}$ | $f = 1MHz$, $V_{NO} = V_{COM} = 0V$, (See Figure 7) | 25 | - | 18 | - | pF |
| OFF Isolation | $R_L = 50\Omega$, $C_L = 15pF$, $f = 100kHz$, $V_{NO} = 1V_{RMS}$, (See Figures 4 and 6) | 25 | - | 92 | - | dB |
| Crosstalk, (Note 8) | | 25 | - | ≤110 | - | dB |
| All Hostile Crosstalk, (Note 8) | | 25 | - | -105 | - | dB |
| POWER SUPPLY CHARACTERISTICS | | | | | | |
| Power Supply Range | | Full | ±2 | - | ±6 | V |
| Positive Supply Current, I_+ | $V_S = \pm 5.5V$, V_{ENH} , $V_{ADD} = 0V$ or V_+ , Switch On or Off | 25 | -1 | 0.1 | 1 | μA |
| | | Full | -1 | - | 1 | μA |
| Negative Supply Current, I_- | | 25 | -1 | 0.1 | 1 | μA |
| | | Full | -1 | - | 1 | μA |

NOTES:

- V_{IN} = logic voltage to configure the device in a given state.
- The algebraic convention, whereby the most negative value is a minimum and the most positive a maximum, is used in this data sheet.
- $\Delta R_{ON} = R_{ON} (MAX) - R_{ON} (MIN)$.
- Flatness is defined as the difference between maximum and minimum value of on-resistance over the specified analog signal range.
- Leakage parameter is 100% tested at high temp, and guaranteed by correlation at 25°C.
- Between any two switches.

Electrical Specifications +12V Supply Test Conditions: $V_+ = +10.8V$ to $+13.2V$, $GND = 0V$, $V_{INH} = 4V$, $V_{INL} = 0.8V$ (Note 3), Unless Otherwise Specified

| PARAMETER | TEST CONDITIONS | TEMP (°C) | (NOTE 4) MIN | TYP | (NOTE 4) MAX | UNITS |
|--|--|-----------|--------------|-------|--------------|-------|
| ANALOG SWITCH CHARACTERISTICS | | | | | | |
| Analog Signal Range, V_{ANALOG} | | Full | 0 | - | V_+ | V |
| ON Resistance, R_{ON} | $V_+ = 10.8V$, $I_{COM} = 1.0mA$, $V_{NO} = 9V$, (See Figure 5) | 25 | - | 37 | 45 | Ω |
| | | Full | - | - | 55 | Ω |
| R_{ON} Matching Between Channels, ΔR_{ON} | $V_+ = 10.8V$, $I_{COM} = 1.0mA$, $V_{NO} = 9V$, (Note 5) | 25 | - | 1.2 | 2 | Ω |
| | | Full | - | - | 2 | Ω |
| R_{ON} Flatness, $R_{FLAT(ON)}$ | $V_+ = 10.8V$, $I_{COM} = 1.0mA$, $V_{NO} = 3V, 6V, 9V$, (Note 6) | 25 | - | 5 | 7 | Ω |
| | | Full | - | - | 7 | Ω |
| NO or NC OFF Leakage Current, $I_{NO(OFF)}$ or $I_{NC(OFF)}$ | $V_+ = 13.2V$, $V_{COM} = 1V, 12V$, $V_{NO} = 12V, 1V$, (Note 7) | 25 | -0.1 | 0.002 | 0.1 | nA |
| | | Full | -2.5 | - | 2.5 | nA |

ISL43840

Electrical Specifications +12V Supply

Test Conditions: $V_+ = +10.8V$ to $+13.2V$, $GND = 0V$, $V_{INH} = 4V$, $V_{INL} = 0.8V$ (Note 3), Unless Otherwise Specified **(Continued)**

| PARAMETER | TEST CONDITIONS | TEMP (°C) | (NOTE 4) MIN | TYP | (NOTE 4) MAX | UNITS |
|--|--|-----------|--------------|------------|--------------|---------|
| COM OFF Leakage Current, $I_{COM(OFF)}$ | $V_+ = 13.2V$, $V_{COM} = 12V$, $1V$, $V_{NO} = 1V$, $12V$, (Note 7) | 25 | -0.1 | 0.002 | 0.1 | nA |
| | | Full | -2.5 | - | 2.5 | nA |
| COM ON Leakage Current, $I_{COM(ON)}$ | $V_+ = 13.2V$, $V_{COM} = 1V$, $12V$, $V_{NO} = 1V$, $12V$, or floating, (Note 7) | 25 | -0.1 | 0.002 | 0.1 | nA |
| | | Full | -2.5 | - | 2.5 | nA |
| DIGITAL INPUT CHARACTERISTICS | | | | | | |
| Input Voltage High, $V_{\overline{EN}H}$, V_{ADDH} | | Full | 3.7 | 3.3 | - | V |
| Input Voltage Low, $V_{\overline{EN}L}$, V_{ADDL} | | Full | - | 2.7 | 0.8 | V |
| Input Current, $I_{\overline{EN}H}$, $I_{\overline{EN}L}$, I_{ADDH} , I_{ADDL} | $V_+ = 13.2V$, $V_{\overline{EN}H}$, $V_{ADD} = 0V$ or V_+ | Full | -0.5 | 0.03 | 0.5 | μA |
| DYNAMIC CHARACTERISTICS | | | | | | |
| Enable Turn-ON Time, t_{ON} | $V_+ = 10.8V$, $V_{NO} = 10V$, $R_L = 300\Omega$, $C_L = 35pF$, $V_{IN} = 0$ to 4 , (See Figure 1) | 25 | - | 24 | 40 | ns |
| | | Full | - | - | 45 | ns |
| Enable Turn-OFF Time, t_{OFF} | $V_+ = 10.8V$, $V_{NO} = 10V$, $R_L = 300\Omega$, $C_L = 35pF$, $V_{IN} = 0$ to 4 , (See Figure 1) | 25 | - | 15 | 30 | ns |
| | | Full | - | - | 35 | ns |
| Address Transition Time, t_{TRANS} | $V_+ = 10.8V$, $V_{NO} = 10V$, $R_L = 300\Omega$, $C_L = 35pF$, $V_{IN} = 0$ to 4 , (See Figure 1) | 25 | - | 27 | 50 | ns |
| | | Full | - | - | 55 | ns |
| Break-Before-Make Time Delay, t_D | $V_+ = 13.2V$, $R_L = 300\Omega$, $C_L = 35pF$, $V_{NO} = 10V$, $V_{IN} = 0$ to 4 , (See Figure 3) | Full | 2 | 5 | - | ns |
| Charge Injection, Q | $C_L = 1.0nF$, $V_G = 0V$, $R_G = 0\Omega$, (See Figure 2) | 25 | - | 2.7 | 5 | pC |
| OFF Isolation | $R_L = 50\Omega$, $C_L = 15pF$, $f = 100kHz$, $V_{NO} = 1V_{RMS}$, (See Figures 4 and 6) | 25 | - | 92 | - | dB |
| Crosstalk, (Note 8) | | 25 | - | ≤ 110 | - | dB |
| All Hostile Crosstalk, (Note 8) | | 25 | - | -105 | - | dB |
| NO or NC OFF Capacitance, C_{OFF} | $f = 1MHz$, $V_{NO} = V_{COM} = 0V$, (See Figure 7) | 25 | - | 3 | - | pF |
| COM OFF Capacitance, $C_{COM(OFF)}$ | $f = 1MHz$, $V_{NO} = V_{COM} = 0V$, (See Figure 7) | 25 | - | 12 | - | pF |
| COM ON Capacitance, $C_{COM(ON)}$ | $f = 1MHz$, $V_{NO} = V_{COM} = 0V$, (See Figure 7) | 25 | - | 18 | - | pF |
| POWER SUPPLY CHARACTERISTICS | | | | | | |
| Power Supply Range | | Full | 2 | - | 12 | V |
| Positive Supply Current, I_+ | $V_+ = 13.2V$, $V_{\overline{EN}H}$, $V_{ADD} = 0V$ or V_+ , all channels On or Off | Full | -1 | - | 1 | μA |
| Positive Supply Current, I_- | | Full | -1 | - | 1 | μA |

Electrical Specifications: 5V Supply

Test Conditions: $V_+ = +4.5V$ to $+5.5V$, $V_- = GND = 0V$, $V_{INH} = 2.4V$, $V_{INL} = 0.8V$ (Note 3),
Unless Otherwise Specified

| PARAMETER | TEST CONDITIONS | TEMP (°C) | MIN (NOTE 4) | TYP | MAX (NOTE 4) | UNITS |
|--|--|-----------|--------------|------------|--------------|----------|
| ANALOG SWITCH CHARACTERISTICS | | | | | | |
| Analog Signal Range, V_{ANALOG} | | Full | 0 | - | V_+ | V |
| ON Resistance, R_{ON} | $V_+ = 4.5V$, $I_{COM} = 1.0mA$, $V_{NO} = 3.5V$, (See Figure 5) | 25 | - | 81 | 90 | Ω |
| | | Full | - | - | 120 | Ω |
| R_{ON} Matching Between Channels, ΔR_{ON} | $V_+ = 4.5V$, $I_{COM} = 1.0mA$, $V_{NO} = 3V$, (Note 5) | 25 | - | 2.2 | 4 | Ω |
| | | Full | - | - | 6 | Ω |
| R_{ON} Flatness, $R_{FLAT(ON)}$ | $V_+ = 4.5V$, $I_{COM} = 1.0mA$, $V_{NO} = 1V, 2V, 3V$, (Note 6) | 25 | - | 11.5 | 17 | Ω |
| | | Full | - | - | 24 | Ω |
| NO or NC OFF Leakage Current, $I_{NO(OFF)}$ or $I_{NC(OFF)}$ | $V_+ = 5.5V$, $V_{COM} = 1V, 4.5V$, $V_{NO} = 4.5V, 1V$, (Note 7) | 25 | -0.1 | 0.002 | 0.1 | nA |
| | | Full | -2.5 | - | 2.5 | nA |
| COM OFF Leakage Current, $I_{COM(OFF)}$ | $V_+ = 5.5V$, $V_{COM} = 1V, 4.5V$, $V_{NO} = 4.5V, 1V$, (Note 7) | 25 | -0.1 | 0.002 | 0.1 | nA |
| | | Full | -2.5 | - | 2.5 | nA |
| COM ON Leakage Current, $I_{COM(ON)}$ | $V_+ = 5.5V$, $V_{COM} = V_{NO} = 4.5V$, (Note 7) | 25 | -0.1 | 0.002 | 0.1 | nA |
| | | Full | -2.5 | - | 2.5 | nA |
| DIGITAL INPUT CHARACTERISTICS | | | | | | |
| Input Voltage High, $V_{\overline{ENH}}$, V_{ADDH} | | Full | 2.4 | - | - | V |
| Input Voltage Low, $V_{\overline{ENL}}$, V_{ADDL} | | Full | - | - | 0.8 | V |
| Input Current, $I_{\overline{ENH}}$, $I_{\overline{ENL}}$, I_{ADDH} , I_{ADDL} | $V_+ = 5.5V$, $V_{\overline{ENH}}$, $V_{ADD} = 0V$ or V_+ | Full | -0.5 | 0.03 | 0.5 | μA |
| DYNAMIC CHARACTERISTICS | | | | | | |
| Enable Turn-ON Time, t_{ON} | $V_+ = 4.5V$, $V_{NO} = 3V$, $R_L = 300\Omega$, $C_L = 35pF$, $V_{IN} = 0$ to $3V$, (See Figure 1) | 25 | - | 43 | 60 | ns |
| | | Full | - | - | 70 | ns |
| Enable Turn-OFF Time, t_{OFF} | $V_+ = 4.5V$, $V_{NO} = 3V$, $R_L = 300\Omega$, $C_L = 35pF$, $V_{IN} = 0$ to $3V$, (See Figure 1) | 25 | - | 20 | 35 | ns |
| | | Full | - | - | 40 | ns |
| Address Transition Time, t_{TRANS} | $V_+ = 4.5V$, $V_{NO} = 3V$, $R_L = 300\Omega$, $C_L = 35pF$, $V_{IN} = 0$ to $3V$, (See Figure 1) | 25 | - | 51 | 70 | ns |
| | | Full | - | - | 85 | ns |
| Break-Before-Make Time, t_{BBM} | $V_+ = 5.5V$, $V_{NO} = 3V$, $R_L = 300\Omega$, $C_L = 35pF$, $V_{IN} = 0$ to $3V$, (See Figure 3) | Full | 2 | 9 | - | ns |
| Charge Injection, Q | $C_L = 1.0nF$, $V_G = 0V$, $R_G = 0\Omega$, (See Figure 2) | 25 | - | 0.6 | 1.5 | pC |
| OFF Isolation | $R_L = 50\Omega$, $C_L = 15pF$, $f = 100kHz$, $V_{NO} = 1V_{RMS}$, (See Figures 4 and 6) | 25 | - | 92 | - | dB |
| Crosstalk, (Note 8) | | 25 | - | ≤ 110 | - | dB |
| All Hostile Crosstalk, (Note 8) | | 25 | - | -105 | - | dB |
| POWER SUPPLY CHARACTERISTICS | | | | | | |
| Power Supply Range | | Full | 2 | - | 12 | V |
| Positive Supply Current, I_+ | $V_+ = 5.5V$, $V_- = 0V$, $V_{\overline{ENH}}$, $V_{ADD} = 0V$ or V_+ , Switch On or Off | 25 | -1 | -0.1 | 1 | μA |
| | | Full | -1 | - | 1 | μA |
| Positive Supply Current, I_- | | 25 | -1 | -0.1 | 1 | μA |
| | | Full | -1 | - | 1 | μA |

ISL43840

Electrical Specifications: 3.3V Supply

Test Conditions: $V_+ = +3.0V$ to $+3.6V$, $V_- = GND = 0V$, $V_{INH} = 2.4V$, $V_{INL} = 0.8V$ (Note 3), Unless Otherwise Specified

| PARAMETER | TEST CONDITIONS | TEMP (°C) | MIN (NOTE 4) | TYP | MAX (NOTE 4) | UNITS |
|--|---|-----------|--------------|------------|--------------|----------|
| ANALOG SWITCH CHARACTERISTICS | | | | | | |
| Analog Signal Range, V_{ANALOG} | | Full | 0 | - | V_+ | V |
| ON Resistance, R_{ON} | $V_+ = 3.0V$, $I_{COM} = 1.0mA$, $V_{NO} = 1.5V$, (See Figure 5) | 25 | - | 135 | 155 | Ω |
| | | Full | - | - | 200 | Ω |
| R_{ON} Matching Between Channels, ΔR_{ON} | $V_+ = 3.0V$, $I_{COM} = 1.0mA$, $V_{NO} = 1.5V$, (Note 5) | 25 | - | 3.4 | 8 | Ω |
| | | Full | - | - | 10 | Ω |
| R_{ON} Flatness, $R_{FLAT(ON)}$ | $V_+ = 3.0V$, $I_{COM} = 1.0mA$, $V_{NO} = 0.5V, 1V, 2V$, (Note 6) | 25 | - | 34 | 40 | Ω |
| | | Full | - | - | 50 | Ω |
| NO or NC OFF Leakage Current, $I_{NO(OFF)}$ or $I_{NC(OFF)}$ | $V_+ = 3.6V$, $V_{COM} = 0V, 4.5V$, $V_{NO} = 3V, 1V$, (Note 7) | 25 | -0.1 | 0.002 | 0.1 | nA |
| | | Full | -2.5 | - | 2.5 | nA |
| COM OFF Leakage Current, $I_{COM(OFF)}$ | $V_+ = 3.6V$, $V_{COM} = 0V, 4.5V$, $V_{NO} = 3V, 1V$, (Note 7) | 25 | -0.1 | 0.002 | 0.1 | nA |
| | | Full | -2.5 | - | 2.5 | nA |
| COM ON Leakage Current, $I_{COM(ON)}$ | $V_+ = 3.6V$, $V_{COM} = V_{NO} = 3V$, (Note 7) | 25 | -0.1 | 0.002 | 0.1 | nA |
| | | Full | -2.5 | - | 2.5 | nA |
| DIGITAL INPUT CHARACTERISTICS | | | | | | |
| Input Voltage High, $V_{\overline{EN}H}$, V_{ADDH} | | Full | 2.4 | - | - | V |
| Input Voltage Low, $V_{\overline{EN}L}$, V_{ADDL} | | Full | - | - | 0.8 | V |
| Input Current, $I_{\overline{EN}H}$, $I_{\overline{EN}L}$, I_{ADDH} , I_{ADDL} | $V_+ = 3.6V$, $V_{\overline{EN}H}$, $V_{ADD} = 0V$ or V_+ | Full | -0.5 | 0.03 | 0.5 | μA |
| DYNAMIC CHARACTERISTICS | | | | | | |
| Enable Turn-ON Time, t_{ON} | $V_+ = 3.0V$, $V_{NO} = 1.5V$, $R_L = 300\Omega$, $C_L = 35pF$, $V_{IN} = 0$ to $3V$, (See Figure 1) | 25 | - | 82 | 100 | ns |
| | | Full | - | - | 120 | ns |
| Enable Turn-OFF Time, t_{OFF} | $V_+ = 3.0V$, $V_{NO} = 1.5V$, $R_L = 300\Omega$, $C_L = 35pF$, $V_{IN} = 0$ to $3V$, (See Figure 1) | 25 | - | 37 | 50 | ns |
| | | Full | - | - | 60 | ns |
| Address Transition Time, t_{TRANS} | $V_+ = 3.0V$, $V_{NO} = 1.5V$, $R_L = 300\Omega$, $C_L = 35pF$, $V_{IN} = 0$ to $3V$, (See Figure 1) | 25 | - | 96 | 120 | ns |
| | | Full | - | - | 145 | ns |
| Break-Before-Make Time, t_{BBM} | $V_+ = 3.6V$, $V_{NO} = 1.5V$, $R_L = 300\Omega$, $C_L = 35pF$, $V_{IN} = 0$ to $3V$, (See Figure 3) | Full | 3 | 13 | - | ns |
| Charge Injection, Q | $C_L = 1.0nF$, $V_G = 0V$, $R_G = 0\Omega$, (See Figure 2) | 25 | - | 0.3 | 1 | pC |
| OFF Isolation | $R_L = 50\Omega$, $C_L = 15pF$, $f = 100kHz$, $V_{NO} = 1V_{RMS}$, (See Figures 4 and 6) | 25 | - | 92 | - | dB |
| Crosstalk, (Note 8) | | 25 | - | ≤ 110 | - | dB |
| All Hostile Crosstalk, (Note 8) | | 25 | - | -105 | - | dB |
| POWER SUPPLY CHARACTERISTICS | | | | | | |
| Power Supply Range | | Full | 2 | - | 12 | V |
| Positive Supply Current, I_+ | $V_+ = 3.6V$, $V_- = 0V$, $V_{\overline{EN}H}$, $V_{ADD} = 0V$ or V_+ , Switch On or Off | 25 | -1 | -0.1 | 1 | μA |
| | | Full | -1 | - | 1 | μA |
| Positive Supply Current, I_- | | 25 | -1 | -0.1 | 1 | μA |
| | | Full | -1 | - | 1 | μA |

Test Circuits and Waveforms

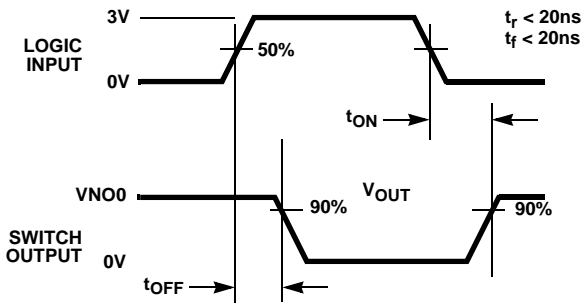

Logic input waveform is inverted for switches that have the opposite logic sense.

FIGURE 1A. ENABLE t_{ON} / t_{OFF} MEASUREMENT POINTS

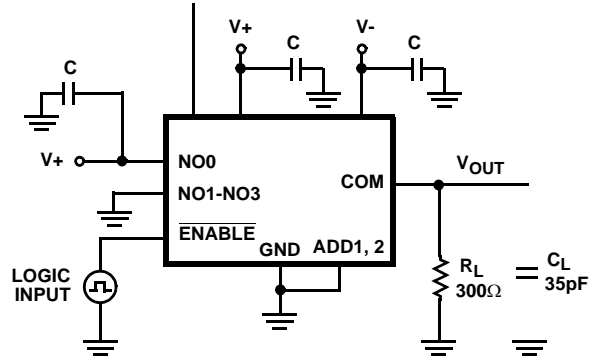

Repeat test for other switches. C_L includes fixture and stray capacitance.

$$V_{OUT} = V_{(NO)} \frac{R_L}{R_L + R_{(ON)}}$$

FIGURE 1B. ENABLE t_{ON} / t_{OFF} TEST CIRCUIT

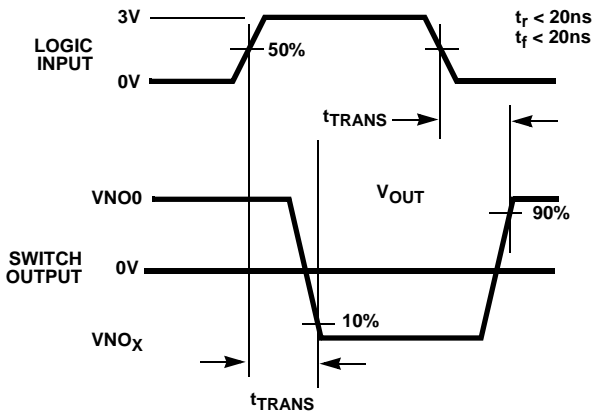

Logic input waveform is inverted for switches that have the opposite logic sense.

FIGURE 1C. ADDRESS t_{TRANS} MEASUREMENT POINTS

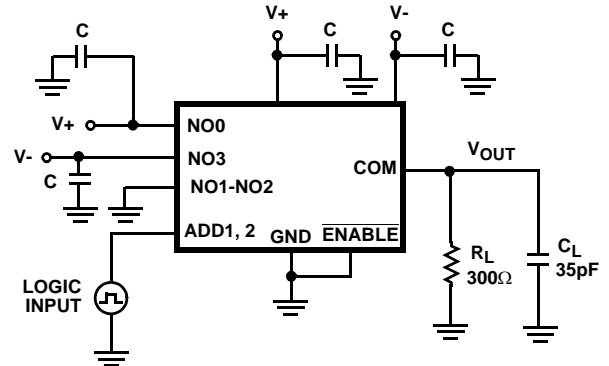

Repeat test for other switches. C_L includes fixture and stray capacitance.

$$V_{OUT} = V_{(NO)} \frac{R_L}{R_L + R_{(ON)}}$$

FIGURE 1D. ADDRESS t_{TRANS} TEST CIRCUIT

FIGURE 1. SWITCHING TIMES

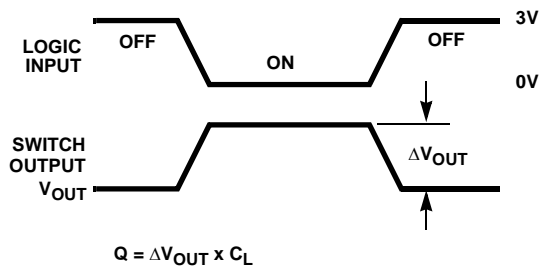
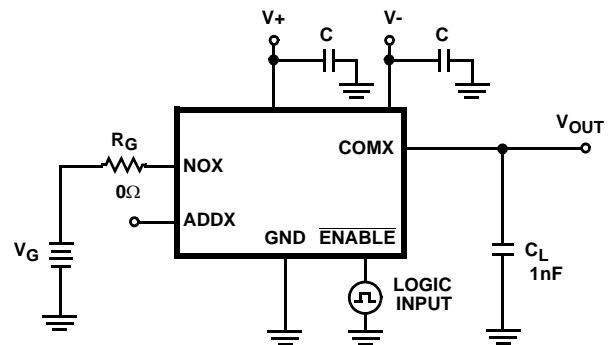

FIGURE 2A. Q MEASUREMENT POINTS



Repeat test for other switches.

FIGURE 2B. Q TEST CIRCUIT

FIGURE 2. CHARGE INJECTION

Test Circuits and Waveforms (Continued)

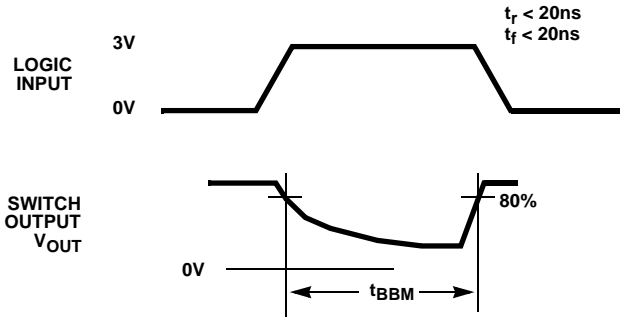
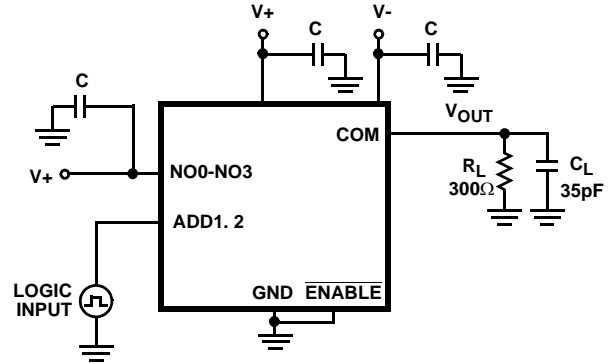

FIGURE 3A. t_{BBM} MEASUREMENT POINTS



Repeat test for other switches. C_L includes fixture and stray capacitance.

FIGURE 3B. t_{BBM} TEST CIRCUIT

FIGURE 3. BREAK-BEFORE-MAKE TIME

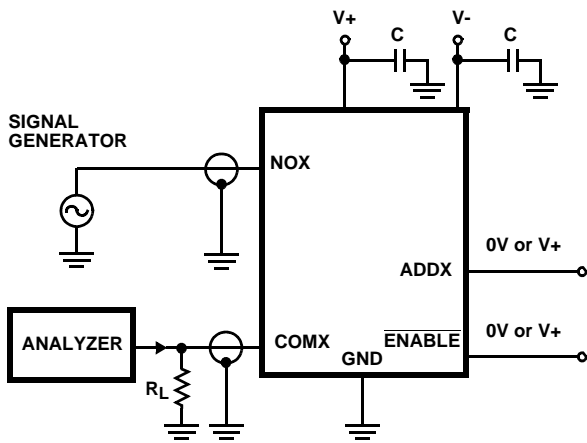

FIGURE 4. OFF ISOLATION TEST CIRCUIT

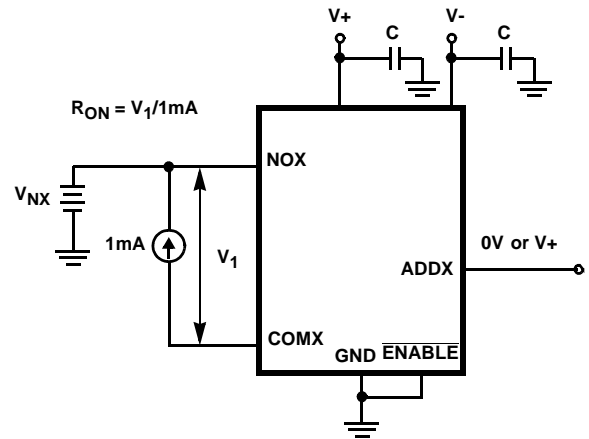

FIGURE 5. R_{ON} TEST CIRCUIT

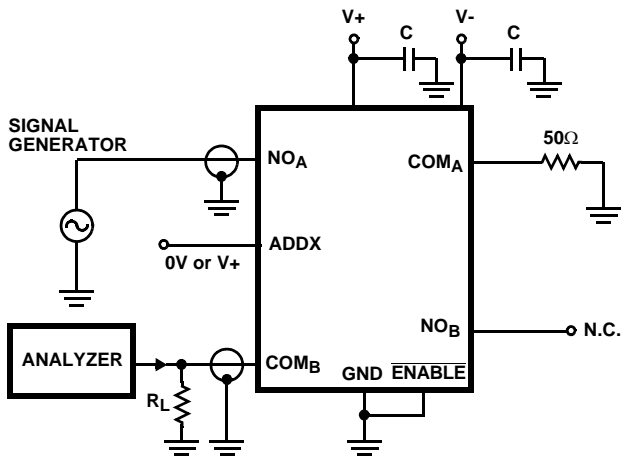

FIGURE 6. CROSSTALK TEST CIRCUIT

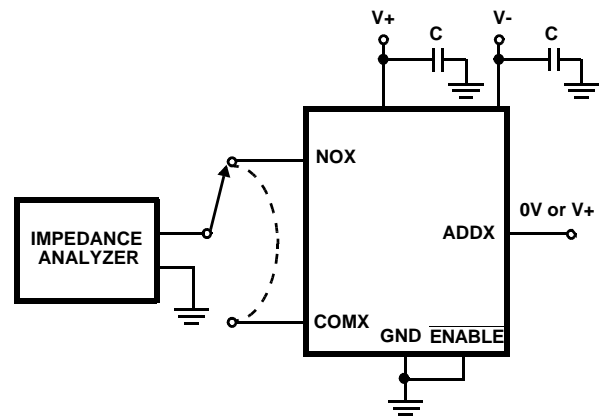

FIGURE 7. CAPACITANCE TEST CIRCUIT

Detailed Description

The ISL43840 analog switch offers a precise switching capability from a bipolar $\pm 2\text{V}$ to $\pm 6\text{V}$ or a single 2V to 12V supply with low on-resistance (39Ω) and high speed operation ($t_{\text{ON}} = 38\text{ns}$, $t_{\text{OFF}} = 19\text{ns}$) with dual 5V supplies.

It has an enable bar pin to simultaneously open all signal paths.

The device is especially well suited for applications using $\pm 5\text{V}$ supplies. With $\pm 5\text{V}$ supplies the performance (R_{ON} , Leakage, Charge Injection, ect.) is best in class.

High frequency applications also benefit from the wide bandwidth, and the very high off isolation and crosstalk rejection.

Supply Sequencing And Overvoltage Protection

With any CMOS device, proper power supply sequencing is required to protect the device from excessive input currents which might permanently damage the IC. All I/O pins contain ESD protection diodes from the pin to $V+$ and to $V-$ (see Figure 8). To prevent forward biasing these diodes, $V+$ and $V-$ must be applied before any input signals, and input signal voltages must remain between $V+$ and $V-$. If these conditions cannot be guaranteed, then one of the following two protection methods should be employed.

Logic inputs can easily be protected by adding a $1\text{k}\Omega$ resistor in series with the input (see Figure 8). The resistor limits the input current below the threshold that produces permanent damage, and the sub-microamp input current produces an insignificant voltage drop during normal operation.

This method is not applicable for the signal path inputs. Adding a series resistor to the switch input defeats the purpose of using a low R_{ON} switch, so two small signal diodes can be added in series with the supply pins to provide overvoltage protection for all pins (see Figure 8). These additional diodes limit the analog signal from 1V below $V+$ to 1V above $V-$. The low leakage current performance is unaffected by this approach, but the switch resistance may increase, especially at low supply voltages.

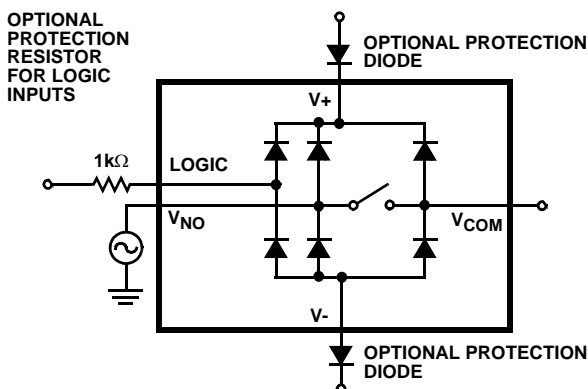

FIGURE 8. INPUT OVERVOLTAGE PROTECTION

Power-Supply Considerations

The ISL43840 construction is typical of most CMOS analog switches, in that they have three supply pins: $V+$, $V-$, and GND . $V+$ and $V-$ drive the internal CMOS switches and set their analog voltage limits, so there are no connections between the analog signal path and GND . Unlike switches with a 13V maximum supply voltage, the ISL43840 15V maximum supply voltage provides plenty of room for the 10% tolerance of 12V supplies ($\pm 6\text{V}$ or 12V single supply), as well as room for overshoot and noise spikes.

This switch device performs equally well when operated with bipolar or single voltage supplies. The minimum recommended supply voltage is 2V or $\pm 2\text{V}$. It is important to note that the input signal range, switching times, and on-resistance degrade at lower supply voltages. Refer to the electrical specification tables and *Typical Performance Curves* for details.

$V+$ and GND power the internal logic (thus setting the digital switching point) and level shifters. The level shifters convert the logic levels to switched $V+$ and $V-$ signals to drive the analog switch gate terminals.

Logic-Level Thresholds

$V+$ and GND power the internal logic stages, so $V-$ has no affect on logic thresholds. This switch family is TTL compatible (0.8V and 2.4V) over a $V+$ supply range of 2.7V to 10V . At 12V the V_{IH} level is about 3.3V . This is still below the CMOS guaranteed high output minimum level of 4V , but noise margin is reduced. For best results with a 12V supply, use a logic family that provides a V_{OH} greater than 4V .

The digital input stages draw supply current whenever the digital input voltage is not at one of the supply rails. Driving the digital input signals from GND to $V+$ with a fast transition time minimizes power dissipation.

High-Frequency Performance

In 50Ω systems, signal response is reasonably flat even past 100MHz (see Figures 17 and 18). Figures 17 and 18 also illustrates that the frequency response is very consistent over varying analog signal levels.

An OFF switch acts like a capacitor and passes higher frequencies with less attenuation, resulting in signal feed through from a switch's input to its output. Off Isolation is the resistance to this feed through, while Crosstalk indicates the amount of feed through from one switch to another. Figure 19 details the high Off Isolation and Crosstalk rejection provided by this family. At 10MHz , Off Isolation is about 55dB in 50Ω systems, decreasing approximately 20dB per decade as frequency increases. Higher load impedances decrease Off Isolation and Crosstalk rejection due to the voltage divider action of the switch OFF impedance and the load impedance.

Leakage Considerations

Reverse ESD protection diodes are internally connected between each analog-signal pin and both V+ and V-. One of these diodes conducts if any analog signal exceeds V+ or V-.

Virtually all the analog leakage current comes from the ESD diodes to V+ or V-. Although the ESD diodes on a given signal pin are identical and therefore fairly well balanced, they are reverse biased differently. Each is biased by either

V+ or V- and the analog signal. This means their leakages will vary as the signal varies. The difference in the two diode leakages to the V+ and V- pins constitutes the analog-signal-path leakage current. All analog leakage current flows between each pin and one of the supply terminals, not to the other switch terminal. This is why both sides of a given switch can show leakage currents of the same or opposite polarity. There is no connection between the analog signal paths and GND.

Typical Performance Curves $T_A = 25^\circ\text{C}$, Unless Otherwise Specified

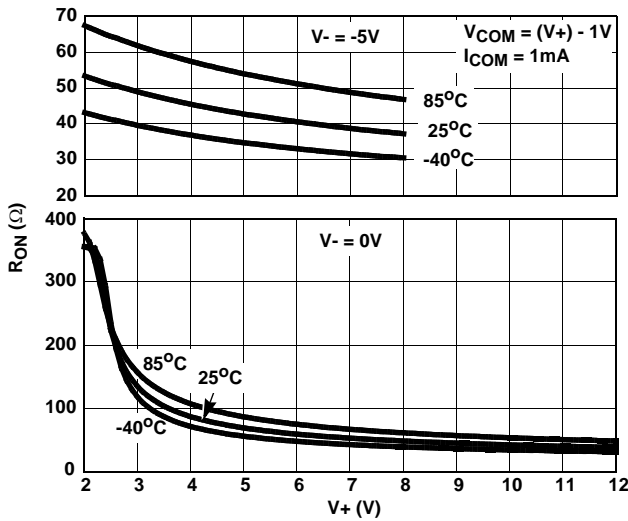

FIGURE 9. ON RESISTANCE vs SUPPLY VOLTAGE

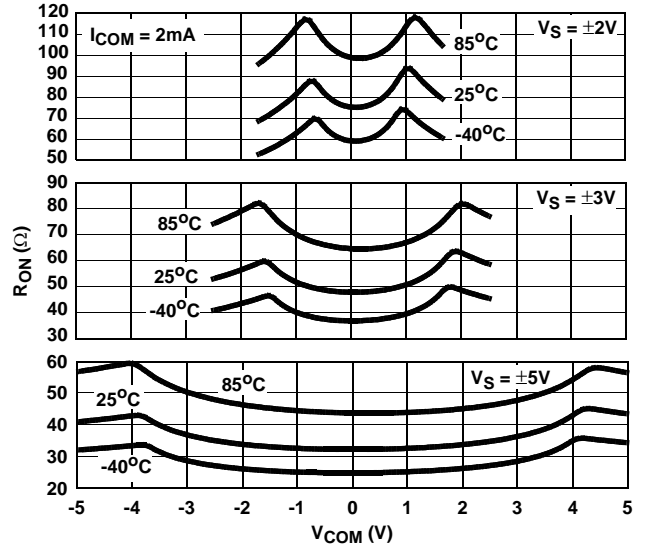

FIGURE 10. ON RESISTANCE vs SWITCH VOLTAGE

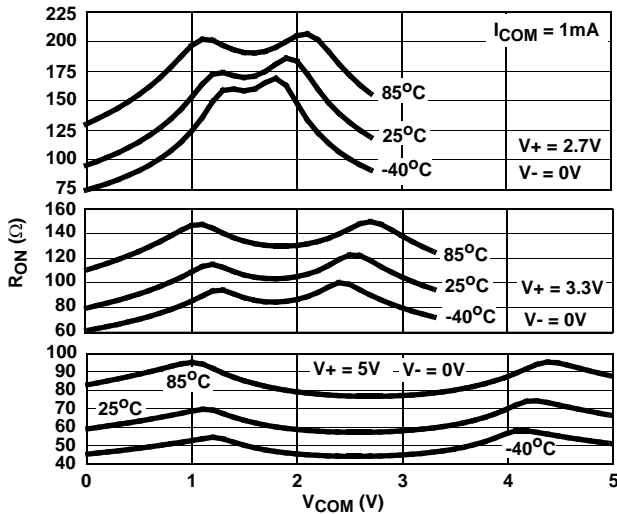

FIGURE 11. ON RESISTANCE vs SWITCH VOLTAGE

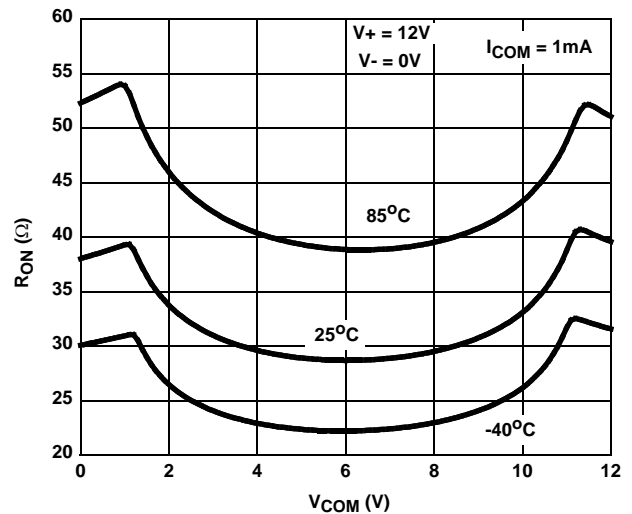

FIGURE 12. ON RESISTANCE vs SWITCH VOLTAGE

Typical Performance Curves $T_A = 25^\circ\text{C}$, Unless Otherwise Specified (Continued)

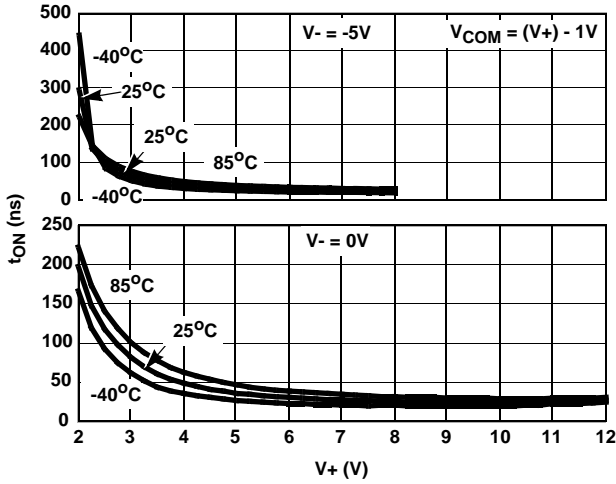

FIGURE 13. ENABLE TURN - ON TIME vs SUPPLY VOLTAGE

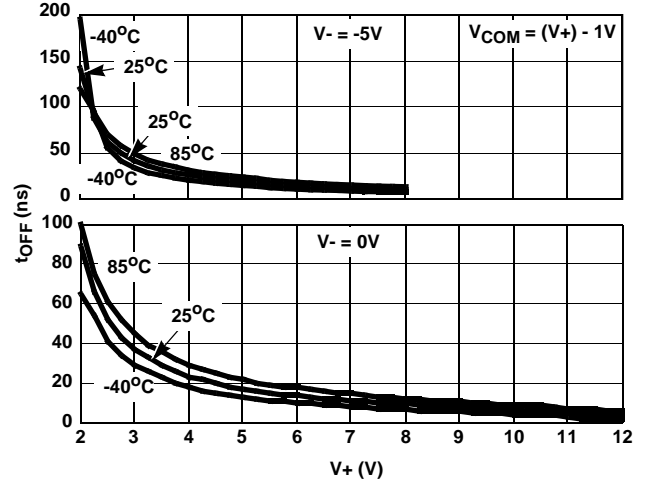

FIGURE 14. ENABLE TURN - OFF TIME vs SUPPLY VOLTAGE

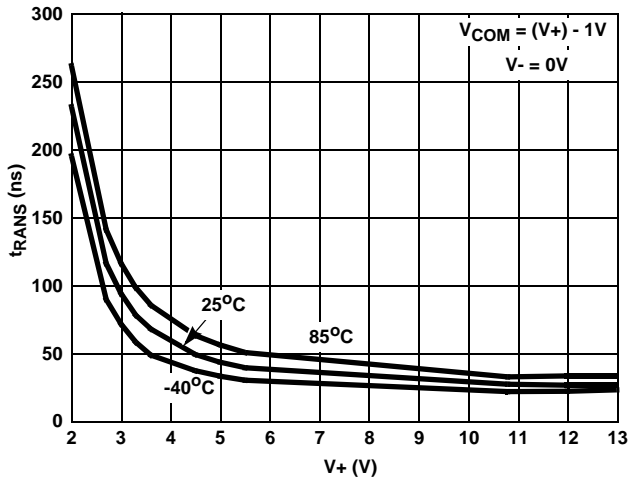

FIGURE 15. ADDRESS TRANS TIME vs SINGLE SUPPLY VOLTAGE

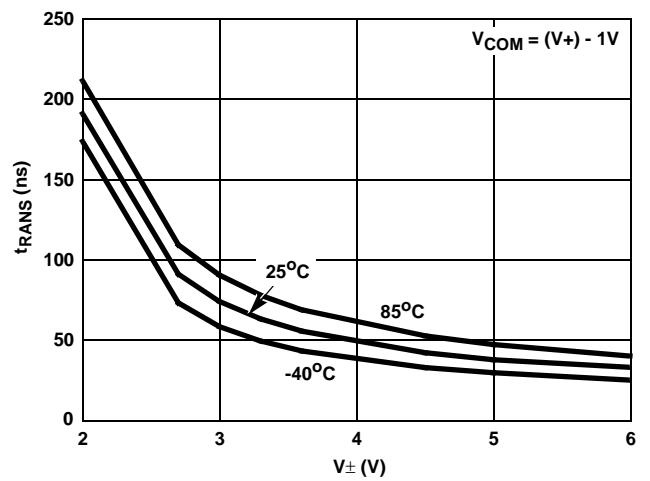

FIGURE 16. ADDRESS TRANS TIME vs DUAL SUPPLY VOLTAGE

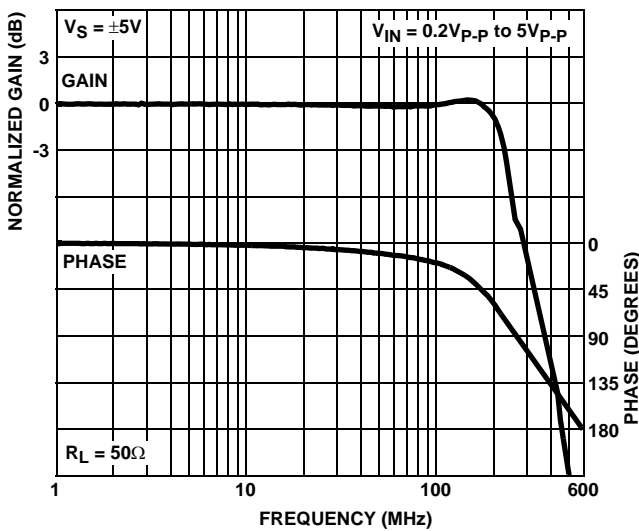

FIGURE 17. FREQUENCY RESPONSE

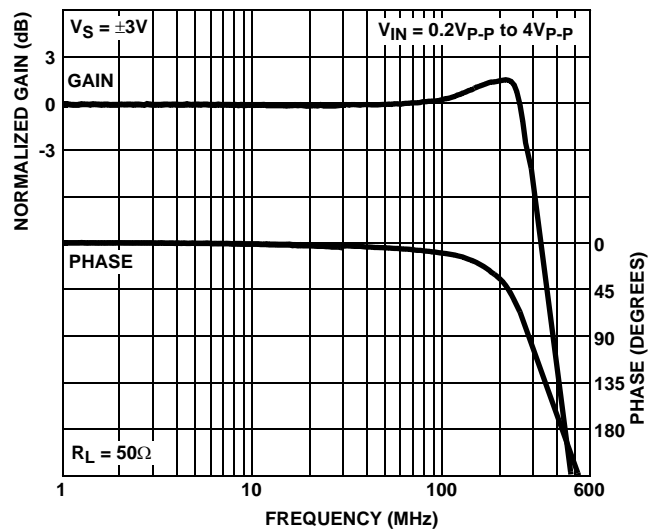

FIGURE 18. FREQUENCY RESPONSE

Typical Performance Curves $T_A = 25^\circ\text{C}$, Unless Otherwise Specified (Continued)

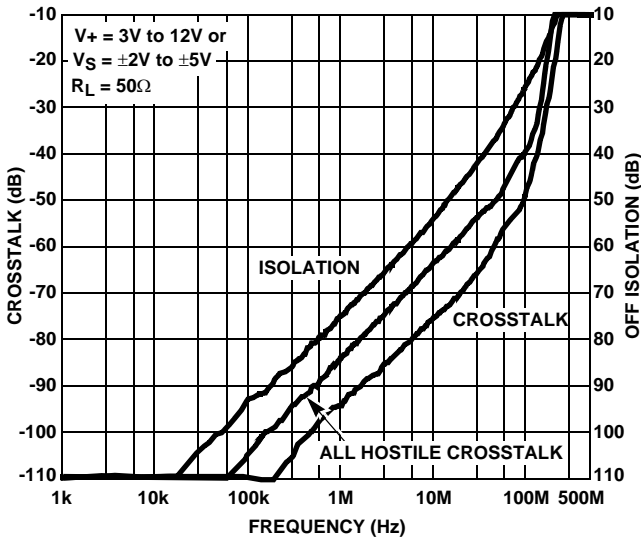

FIGURE 19. CROSSTALK AND OFF ISOLATION

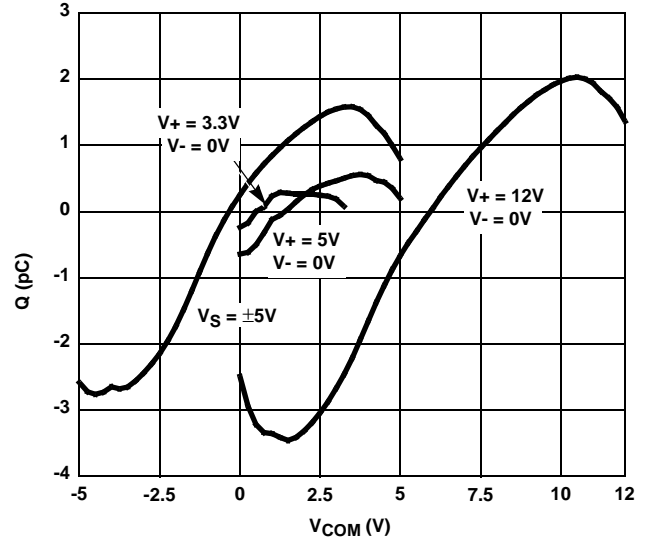

FIGURE 20. CHARGE INJECTION vs SWITCH VOLTAGE

Die Characteristics

SUBSTRATE POTENTIAL (POWERED UP):

GND

TRANSISTOR COUNT:

193

PROCESS:

Si Gate CMOS

**Quad Flat No-Lead Plastic Package (QFN)
Micro Lead Frame Plastic Package (MLFP)**

L20.4x4

20 LEAD QUAD FLAT NO-LEAD PLASTIC PACKAGE
(COMPLIANT TO JEDEC MO-220VGGD-1 ISSUE C)

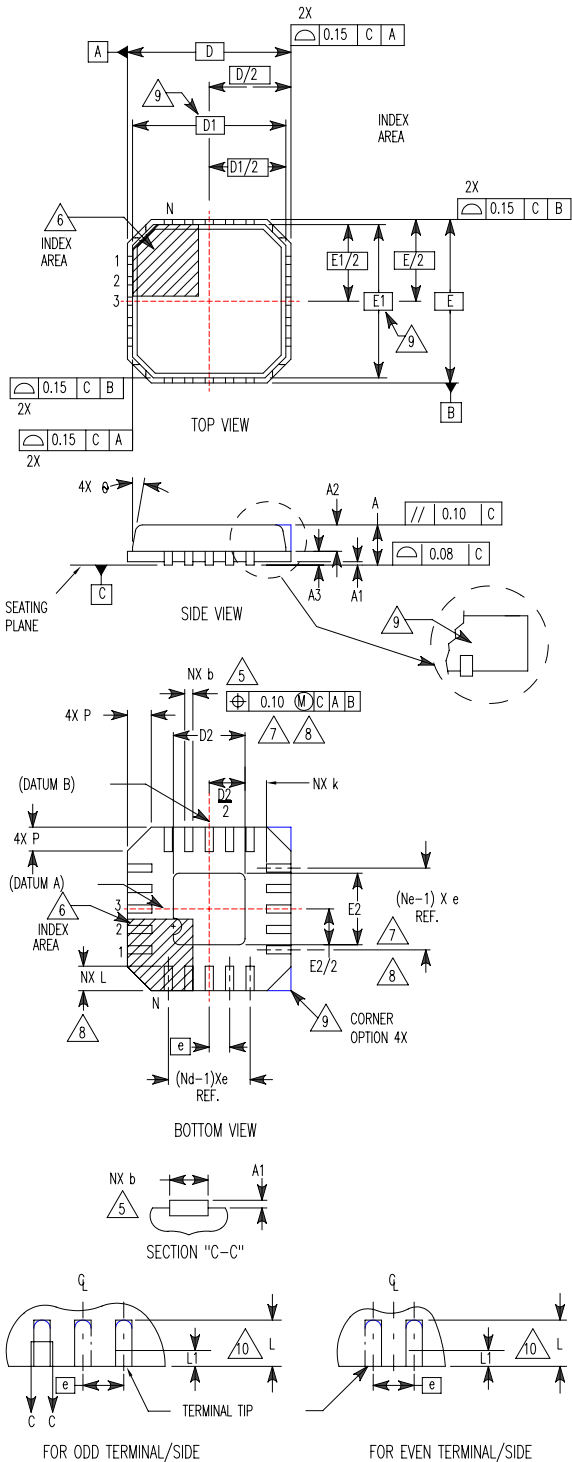

| SYMBOL | MILLIMETERS | | | NOTES |
|--------|-------------|---------|------|-------|
| | MIN | NOMINAL | MAX | |
| A | 0.80 | 0.90 | 1.00 | - |
| A1 | - | - | 0.05 | - |
| A2 | - | - | 1.00 | 9 |
| A3 | 0.20 REF | | | 9 |
| b | 0.18 | 0.23 | 0.30 | 5, 8 |
| D | 4.00 BSC | | | - |
| D1 | 3.75 BSC | | | 9 |
| D2 | 1.95 | 2.10 | 2.25 | 7, 8 |
| E | 4.00 BSC | | | - |
| E1 | 3.75 BSC | | | 9 |
| E2 | 1.95 | 2.10 | 2.25 | 7, 8 |
| e | 0.50 BSC | | | - |
| k | 0.25 | - | - | - |
| L | 0.35 | 0.60 | 0.75 | 8 |
| L1 | - | - | 0.15 | 10 |
| N | 20 | | | 2 |
| Nd | 5 | | | 3 |
| Ne | 5 | 5 | - | 3 |
| P | - | - | 0.60 | 9 |
| θ | - | - | 12 | 9 |

Rev. 1 10/02

NOTES:

1. Dimensioning and tolerancing conform to ASME Y14.5-1994.
2. N is the number of terminals.
3. Nd and Ne refer to the number of terminals on each D and E.
4. All dimensions are in millimeters. Angles are in degrees.
5. Dimension b applies to the metallized terminal and is measured between 0.15mm and 0.30mm from the terminal tip.
6. The configuration of the pin #1 identifier is optional, but must be located within the zone indicated. The pin #1 identifier may be either a mold or mark feature.
7. Dimensions D2 and E2 are for the exposed pads which provide improved electrical and thermal performance.
8. Nominal dimensions are provided to assist with PCB Land Pattern Design efforts, see Intersil Technical Brief TB389.
9. Features and dimensions A2, A3, D1, E1, P & θ are present when Anvil singulation method is used and not present for saw singulation.
10. Depending on the method of lead termination at the edge of the package, a maximum 0.15mm pull back (L1) maybe present. L minus L1 to be equal to or greater than 0.3mm.

All Intersil U.S. products are manufactured, assembled and tested utilizing ISO9000 quality systems.

Intersil Corporation's quality certifications can be viewed at www.intersil.com/design/quality

Intersil products are sold by description only. Intersil Corporation reserves the right to make changes in circuit design, software and/or specifications at any time without notice. Accordingly, the reader is cautioned to verify that data sheets are current before placing orders. Information furnished by Intersil is believed to be accurate and reliable. However, no responsibility is assumed by Intersil or its subsidiaries for its use; nor for any infringements of patents or other rights of third parties which may result from its use. No license is granted by implication or otherwise under any patent or patent rights of Intersil or its subsidiaries.

For information regarding Intersil Corporation and its products, see www.intersil.com