

Driver circuit for NMOS linear image sensor C7885 series

Driver circuit for voltage-output type NMOS linear image sensor

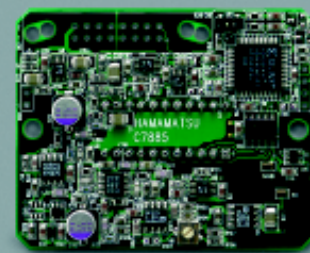

C7885

C7885 series is a driver circuit specifically designed for the Hamamatsu voltage-output type NMOS linear image sensors (S3921 to S3924 series). NMOS linear image sensors are self-scanning photodiode arrays integrated with a scanning circuit of N-channel MOS transistors. C7885 series supplies start pulses, 2-phase clock pulses and reset pulses necessary for voltage-output type image sensor operation. C7885 series also includes a signal processing circuit that inverts and amplifies video signals from an image sensor. C7885 series operates by input of a master start pulse, master clock pulse and connection to a power supply (+12 V or +15 V).

Features

- Suitable for voltage-output type image sensors
- Compact (compared to conventional type C4074)
- Single power supply (+12 V or +15 V) operation

■ Selection guide

Type No.	Product name	Feature
C7885	Driver circuit	High-speed driver circuit for voltage-output type NMOS linear image sensors. Has no input/output connector.
C7885G	Driver circuit + Pulse generator	A dedicated pulse generator is pre-mounted on the driver circuit board. Has no input/output connector.

Note)

- 1: Standard input/output connector is FAP-16-07#2 (made by Yamaichi, sold separately). Equivalent connectors are available from other manufacturers.
- 2: Custom products with an input/output connector pre-mounted are available on request. Please consult our sales office.
- 3: When ordering along with a dedicated cable (A8226), C7885 will be shipped with a mating connector pre-mounted.
- 4: We welcome custom requests. Feel free to contact our sales office.
- 5: When using current-output type NMOS linear image sensors, refer to C7883/C7884 series data sheets.

■ Specifications (Ta=25 °C)

Parameter	Symbol	Condition	Min.	Typ.	Max.	Unit
Supply voltage	+Vs		+11.5	+12.0	+15.5	V
Current consumption	+Is	+12 V	-	30	40	mA
		+12 V	-	60	80	mA
Operation frequency	-	Master clock frequency: 3 MHz	-	-	500	kHz
Gain	G		-	6	-	V/V
Operating temperature	Topr		0 to +50 *			°C
Storage temperature	Tstg		-10 to +60 *			°C

* No condensation

■ Timing chart

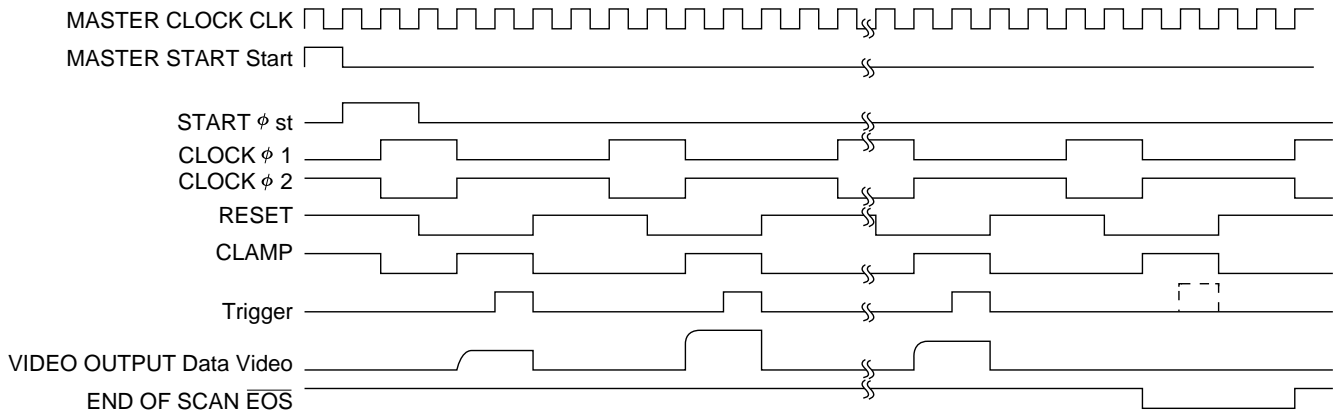

KACCC0120EA

■ Dimensional outlines and input/output signal descriptions (unit: mm)

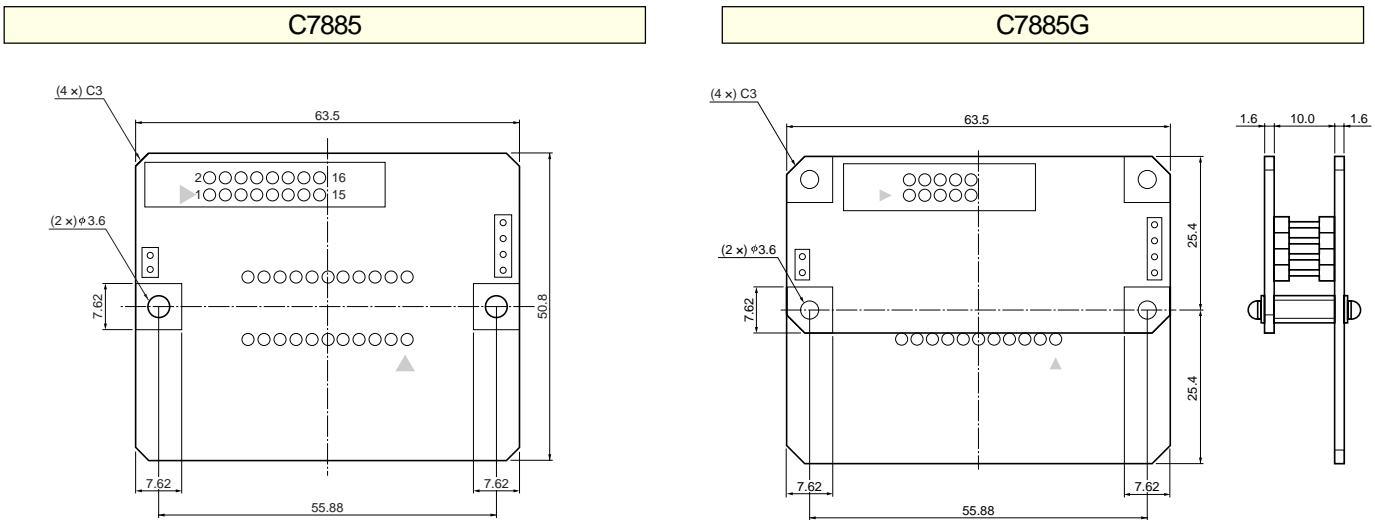

KACCA0086EA

KACCA0106EA

Terminal No.	Terminal name	Description
1	A. GND	Analog ground
2	+12 V or +15 V	Power supply
3	A. GND	Analog ground
4	NC	No connection
5	A. GND	Analog ground
6	Data Video	Analog video signal output; positive polarity
7	A. GND	Analog ground
8	A. GND	Analog ground
9	D. GND	Digital ground
10	$\overline{\text{EOS}}$	Digital output signal indicating end of scan; negative logic
11	D. GND	Digital ground
12	Trigger	Digital output signal for A/D conversion; positive logic
13	D. GND	Digital ground
14	CLK	Digital input signal for operating the circuit at the rising edge (in case of C7885G, output signal)
15	D. GND	Digital ground
16	Start	Digital input signal for initializing the circuit; positive logic. (in case of C7885G, output signal) Interval of these pulses equals the integration time of the sensor.

Dedicated cable A8226

Connector on board: UFS-16B-01

Input/output signal connector: BNC (Start, CLK, Trigger, EOS, Data Video)

Power supply: lose wire cable

Cable length: 1 m

Note) When making a simple in-circuit evaluation of NMOS linear image sensors without any troublesome soldering, use C7883G, C7884G, C7884G-01 or G7885G in combination with A8226.

All you have to do is just insert an NMOS linear image sensor into the socket and connect the cables to an oscilloscope, power supply and AD converter. Note that NMOS linear image sensors are sold separately.

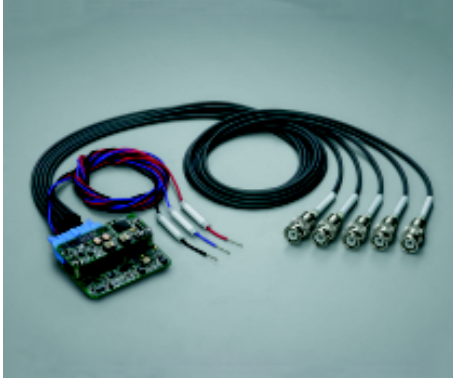

C7884G used in combination with A8226

HAMAMATSU

Information furnished by HAMAMATSU is believed to be reliable. However, no responsibility is assumed for possible inaccuracies or omissions. Specifications are subject to change without notice. No patent rights are granted to any of the circuits described herein. ©2007 Hamamatsu Photonics K.K.

HAMAMATSU PHOTONICS K.K., Solid State Division

1126-1 Ichino-cho, Higashi-ku, Hamamatsu City, 435-8558 Japan, Telephone: (81) 53-434-3311, Fax: (81) 53-434-5184, www.hamamatsu.com

U.S.A.: Hamamatsu Corporation: 360 Foothill Road, P.O.Box 6910, Bridgewater, N.J. 08807-0910, U.S.A., Telephone: (1) 908-231-0960, Fax: (1) 908-231-1218

Germany: Hamamatsu Photonics Deutschland GmbH: Arzbergerstr. 10, D-82211 Herrsching am Ammersee, Germany, Telephone: (49) 08152-3750, Fax: (49) 08152-2658

France: Hamamatsu Photonics France S.A.R.L.: 19, Rue du Saule Trapu, Parc du Moulin de Massy, 91882 Massy Cedex, France, Telephone: 33-(1) 69 53 71 00, Fax: 33-(1) 69 53 71 10

United Kingdom: Hamamatsu Photonics UK Limited: 2 Howard Court, 10 Tewin Road, Welwyn Garden City, Hertfordshire AL7 1BW, United Kingdom, Telephone: (44) 1707-294888, Fax: (44) 1707-325777

North Europe: Hamamatsu Photonics Norden AB: Smidesvägen 12, SE-171 41 Solna, Sweden, Telephone: (46) 8-509-031-00, Fax: (46) 8-509-031-01

Italy: Hamamatsu Photonics Italia S.R.L.: Strada della Moia, 1/E, 20020 Arese, (Milano), Italy, Telephone: (39) 02-935-81-733, Fax: (39) 02-935-81-741