

TOSHIBA Bipolar Linear Integrated Circuit Silicon Monolithic

# TA2099N, TA2099F

AM/FM IF + FM Stereo Detector  
(for Digital Tuning System)

TA2099N and TA2099F are the AM/FM IF + FM Stereo Detector IC, which is designed for DTS Radios. This is included many functions and this can be used for Digital Tuning System with IF Counter.

## Features

- Suitable for combination with Digital Tuning System which has IF Counter.
  - AM/FM IF Count Output for IF Counter
  - Built-in mute Circuit for IF Count Output
  - Built-in mute Circuit for Audio Output
  - FM IF Count Output Sensitivity is adjustable by external resistance
- Built-in FM Narrow Detector Circuit
  - Band Width is adjustable by external resistance
- FM LED ON sensitivity is adjustable by external resistance
- Built-in Resonance Circuit for FM Stereo Detector VCO
- Built-in FM Blender Control Circuit
- Built-in Anti-birdie Circuit
- Built-in AM Local OSC Buffer Output Circuit
- Operating Supply Voltage Range:  $V_{CC} = 4.0\sim 9\text{ V}$  ( $T_a = 25^\circ\text{C}$ )

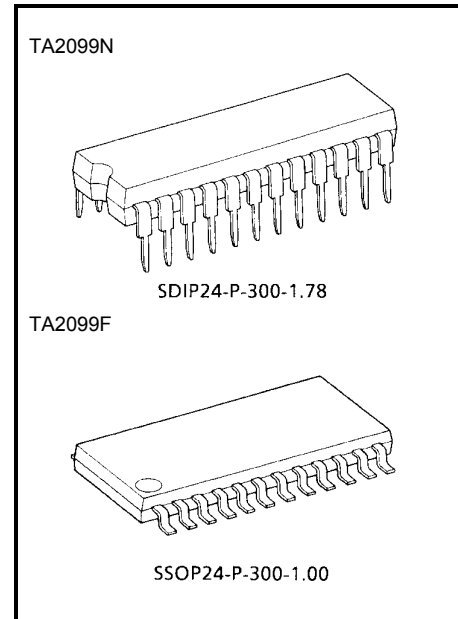

Weight:  
SDIP24-P-300-1.78: 1.2 g (typ.)  
SSOP24-P-300-1.00: 0.31 g (typ.)

## Block Diagram

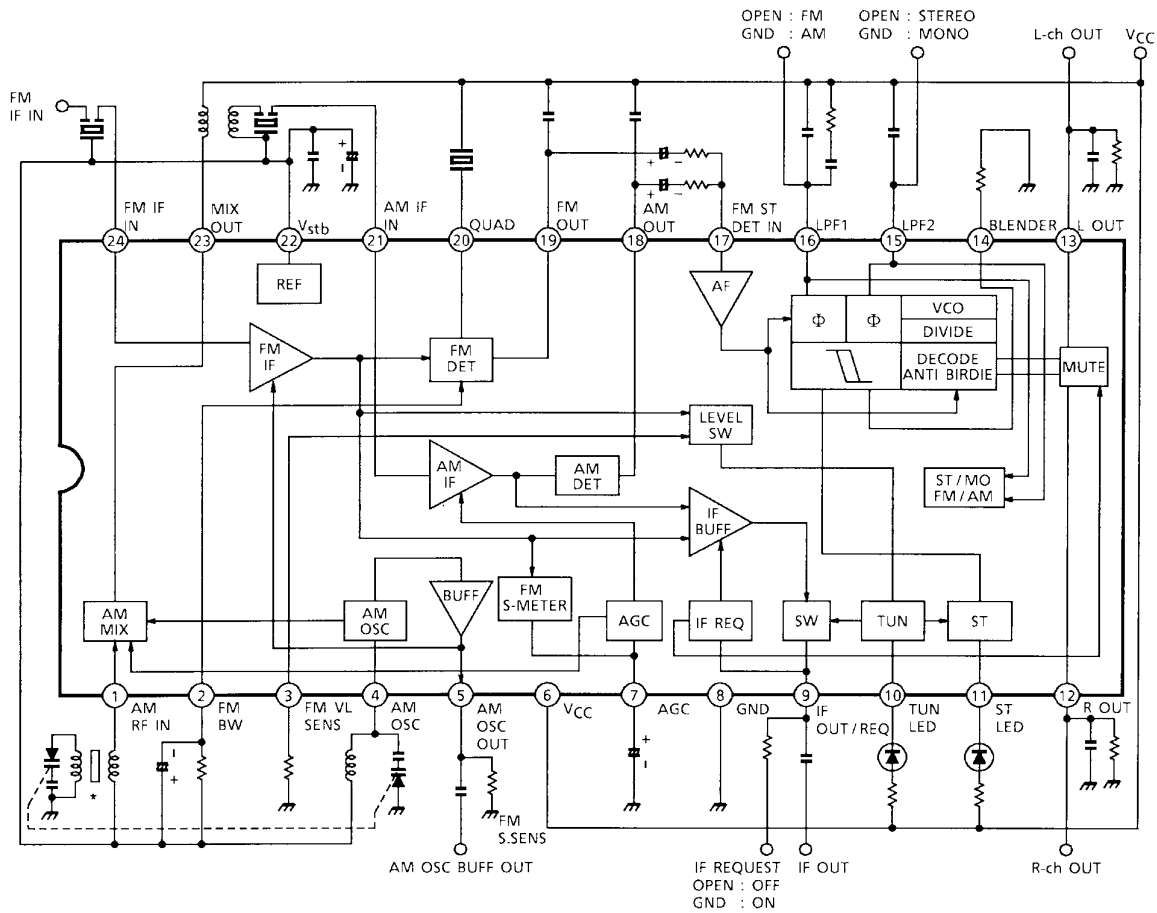

\*: The Toshiba evaluation board uses the bar antenna shown below.

Use	f	L	Q <sub>0</sub>	Number of Windings		Winding Thickness (mm)	Note
				1-2	3-4		
MW ANT	796 kHz	220 μH	150~220	59	17	3/0.07 μATC	Mitsumi L-3107

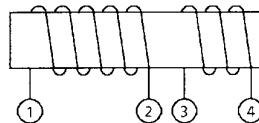

**Terminal Explanation (Terminal voltage shows the typical value at Ta = 25°C, VCC = 5V, SW3: OFF, SW9: GND and non-signal test circuit)**

Pin No.	Characteristics	Internal Circuit	DC Voltage (V)	
			FM	AM
1	AM RF IN		2.0	2.0
2	FM BW • FM band width adjust terminal		2.0	2.0
3	FM VL SENS • FM LED ON sensitivity adjust terminal		0.1	0.1
4	AM OSC		2.0	2.0

Pin No.	Characteristics	Internal Circuit	DC Voltage (V)	
			FM	AM
5	<p>AM OSC OUT/FM S.SENS</p> <ul style="list-style-type: none"> <li>• AM OSC Buff Output Terminal</li> <li>• FFM IF Count Output Sensitivity Adjust Terminal</li> </ul>		1.3	1.3
6	Vcc	—	5.0	5.0
7	AGC (FM S-METER)		0.2	1.3
8	GND	—	0	0
9	<p>IF OUT/REQ</p> <ul style="list-style-type: none"> <li>• IF Count Output Terminal</li> <li>• IF Count Output/FM ST DET Mute Circuit Control Terminal</li> </ul> <p>SW<sub>3</sub>: GND → ON SW<sub>3</sub>: Open → OFF</p>		—	—
10	TUN LED		—	—

Pin No.	Characteristics	Internal Circuit	DC Voltage (V)	
			FM	AM
11	ST LED		—	—
12	R OUT		1.2	1.2
13	L OUT		1.2	1.2
14	BLENDER • FM Blender Control Adjust Terminal		0.3	0.3
15	LPF2 • LPF Terminal for Synchronous Detector • VCO Stop Terminal V <sub>15</sub> = GND → VCO Stop (Monaural) V <sub>15</sub> = Open → VCO Run (Stereo)		3.5	1.4
16	LPF1 • LPF Terminal for Phase Detector • Bias Terminal for AM/FM Switch Circuit V <sub>16</sub> = GND → AM V <sub>16</sub> = Open → FM		3.5	0
17	FM ST DET IN		1.2	1.2

Pin No.	Characteristics	Internal Circuit	DC Voltage (V)	
			FM	AM
18	AM DET OUT		0	1.3
19	FM DET OUT		1.4	2.0
20	QUAD		1.8	2.3
21	AM IF IN		2.0	2.0
22	Vstb		2.0	2.0

Pin No.	Characteristics	Internal Circuit	DC Voltage (V)	
			FM	AM
23	AM MIX OUT		5.0	5.0
24	FM IF IN		2.0	2.0

## Operations in Detail

### 1. Application circuit when using a coil demodulator

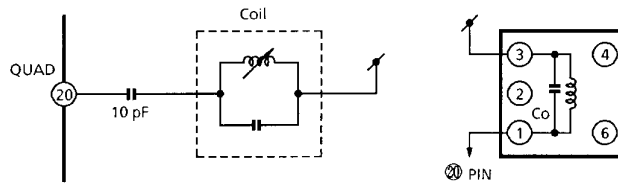

#### Coil data

	f (Hz)	C <sub>o</sub> (pF)	Q <sub>o</sub>	Number of Wire Turns			Wire (mmφ)	Remarks
				1-2	2-3	1-3		
FM DET	10.7 M	51	45			30	0.08 φ 2 UEW	TOKO Co., Ltd. 600BEAS-10018Z

### 2. Center meter adjustment

It can be switch  $\Delta V$ , pin voltages between 2-pin and 22-pin ( $V_{stb}$ ) for narrow band detection or both side of R<sub>2</sub> pin voltages, to 0 V to adjust a coil. This adjustment made possible to set the voltage to center voltage and the midpoint of lighting LED band to the frequency (10.7 MHz).

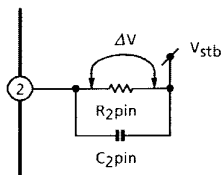

Assembled C<sub>2</sub> pin and R<sub>2</sub> pin compose HPF.

$$f_c = \frac{1}{2\pi RC}$$

Select R<sub>2</sub> pin in accordance with specifications for narrow band detection and set C<sub>2</sub> pin by following that of resistance. Please take these into account.

### 3. Function switching

- (1) FM → AM switching

Pin 16: Connect the LPF1 pin to GND.

(Adjust using external parts so that the voltage does not exceed 0.6 V.)

- (2) SEREO → MONO switching (Note 1)

Pin 15: Connect the LPF2 pin to GND.

(Adjust using external parts so that the voltage does not exceed 0.6 V.)

Note 1: When STEREO/FM is selected, the multiplex VCO frequency changes due to 0.1 μA flow.

- (3) IF OUT → ON switching

Pin 9: When the voltage on the IF OUT/REQ pin is set to 1.3 V or below ( $V_{stb}$  (2 V) –  $V_{be}$  (0.7 V)) and about 500 μA current flows, switch to ON. Toshiba recommends a load of 2.2 kΩ.



#### 4. External change function

- (1) Narrowband detector: When the FM IF input signal is off-center, 10.7 MHz, by a few kHz, the detector turns TUN-LED OFF.  
Pin 2: Adjusts bandwidth using the resistor of the FM BW pin. In combination with the C<sub>2</sub> pin, the R<sub>2</sub> pin configures an HPF. The smaller the pin 2 capacitance, the higher the HPF cutoff. Note that when low-frequency sound is input, although tuning is maintained, the detector may turn TUN-LED OFF.
- (2) LED ON sensitivity adjustment  
Pin 3: Uses the FM VL SENS pin resistor value to change the ON sensitivity of TUN-LED.
- (3) IF counter output sensitivity adjustment (Note 2)  
Pin 5: Uses the FM S. SENS pin resistor value to change the sensitivity of the IF count output at IF count ON.  
  
Note 2: For the LED on sensitivity, (2) and (3) are linked.  
At IF count ON (connect resistor for pin 9 to GND), the internal current depending on the pin 5 resistor value changes the IF amp gain, the S meter startup, and the IF input level (sensitivity).  
The LED ON sensitivity turns the LED ON by comparing the voltage which depends on the pin 3 resistor value with the S meter voltage. The change in S meter startup (sensitivity) at IF count ON causes the LED ON sensitivity set at IF count OFF to change. Therefore, confirm the LED ON sensitivity according to the seek operation specification.
- (4) Blender control  
Pin 14: Changes the MPX L and R signal separation according to the input level set by the resistance.

#### 5. Others

- (1) V<sub>stb</sub>  
Pin 22: Set to 2 V internally.
- (2) QUAD  
Pin 20: Supports both a ceramic discriminator and a detector coil for QUAD. See 1, in Description of Operation.  
Note that when a detector coil is used, S/N and the skew ratio deteriorates.
- (3) L, R output  
Pins 12, 13: L-OUT and R-OUT pins are used for current output. The external resistor is set to output impedance. This is specified when the load is 5.1 kΩ and 0.01 μF.
- (4) AGC  
Pin 7: Also used as the FM S meter.

## Maximum Ratings (Ta = 25°C)

Characteristics		Symbol	Rating	Unit
Supply voltage		V <sub>CC</sub>	10	V
LED current		I <sub>LED</sub>	10	mA
LED voltage		V <sub>LED</sub>	14	V
Power dissipation	TA2099N	P <sub>D</sub> (Note 3)	1200	mW
	TA2099F		400	
Operating temperature		T <sub>opr</sub>	-25~75	°C
Storage temperature		T <sub>stg</sub>	-55~150	°C

Note 3: Derated above 25°C in the proportion of 9.6 mW/°C for TA2099N and of 3.2 mW/°C for TA2099F.

## Electrical Characteristics (unless otherwise specified, Ta = 25°C, V<sub>CC1</sub> = 5 V, SW<sub>3</sub> = OFF, FM IF: f = 10.7 MHz, Δf = ±22.5 kHz, f<sub>m</sub> = 1 kHz, AM: f = 1 MHz, MOD = 30%, f<sub>m</sub> = 1 kHz, FM ST DET: f<sub>m</sub> = 1 kHz)

Characteristics		Symbol	Test Circuit	Test Condition	Min	Typ.	Max	Unit	
Supply current		I <sub>CC</sub> (FM)	1	FM Mode, V <sub>in</sub> = 0	—	17	23	mA	
		I <sub>CC</sub> (AM)	1	AM Mode, V <sub>in</sub> = 0	—	14	20		
FM IF	Input limiting voltage	V <sub>in</sub> (lim)	1	-3dB limiting point	37	41	45	dBμV EMF	
	Recovered output voltage	V <sub>OD</sub> (FM)	1	V <sub>in</sub> = 80dBμV EMF	75	100	125	mVrms	
	Signal to noise ratio	S/N (FM)	1	V <sub>in</sub> = 80dBμV EMF	—	71	—	dB	
	Total harmonic distortion	THD (FM)	1	V <sub>in</sub> = 80dBμV EMF	—	0.1	—	%	
	AM rejection ratio	AMR	1	V <sub>in</sub> = 80dBμV EMF	—	55	—	dB	
	LED on sensitivity	V <sub>L</sub> (FM)	1	I <sub>L</sub> = 1 mA	SW <sub>1</sub> : 0 Ω	—	41	—	dBμV EMF
					SW <sub>1</sub> : 1.2 kΩ	41	46	51	
					SW <sub>1</sub> : 3.3 kΩ	—	54	—	
	IF count output voltage	V <sub>IF</sub> (FM)	1	SW <sub>3</sub> : ON, V <sub>in</sub> = 80dBμV EMF	240	290	—	mV <sub>p-p</sub>	
	IF count output sensitivity	I <sub>Fsens</sub> (FM)	1	SW <sub>3</sub> : ON	SW <sub>2</sub> : 2.2 kΩ	—	58	—	dBμV EMF
SW <sub>2</sub> : 3.3 kΩ					47	53	59		
SW <sub>2</sub> : 4.7 kΩ					—	50	—		
AM	Gain	G <sub>v</sub>	1	V <sub>in</sub> = 23dBμV EMF	28	50	82	mVrms	
	Recovered output voltage	V <sub>OD</sub> (AM)	1	V <sub>in</sub> = 60dBμV EMF	70	100	130	mVrms	
	Signal to noise ratio	S/N (AM)	1	V <sub>in</sub> = 60dBμV EMF	—	45	—	dB	
	Total harmonic distortion	THD (AM)	1	V <sub>in</sub> = 60dBμV EMF	—	0.5	—	%	
	LED on sensitivity	V <sub>L</sub> (AM)	1	I <sub>L</sub> = 1 mA	21	26	31	dBμV EMF	
	Local OSC buffer output voltage	V <sub>OSC</sub> (AM)	1	f <sub>OSC</sub> = 1.45 MHz	350	480	—	mV <sub>p-p</sub>	
			2	f <sub>OSC</sub> = 27 MHz	—	480	—		
	IF count output voltage	V <sub>IF</sub> (AM)	1	SW <sub>3</sub> : ON, V <sub>in</sub> = 60dBμV EMF	250	370	—	mV <sub>p-p</sub>	
IF count output sensitivity	I <sub>Fsens</sub> (AM)	1	SW <sub>3</sub> : ON	—	26	—	dBμV EMF		

Characteristics		Symbol	Test Circuit	Test Condition	Min	Typ.	Max	Unit	
FM ST DET	Max composite input voltage	$V_{in}$ (MAX) (STEREO)	1	L + R = 90%, P = 10% THD = 3%, SW <sub>8</sub> → LPF: ON	—	700	—	mVrms	
	Separation	Sep	1	L + R = 180 mVrms P = 20 mVrms SW <sub>8</sub> → LPF: ON	$f_m$ = 100 Hz	—	45	—	dB
					$f_m$ = 1 kHz	35	45	—	
					$f_m$ = 10 kHz	—	45	—	
	Total harmonic distortion	Mono	THD (MONO)	1	$V_{in}$ = 200 mVrms (MONO)	—	0.05	—	%
		Stereo	THD (STEREO)	1	L + R = 180 mVrms, P = 20 mVrms SW <sub>8</sub> → LPF: ON	—	0.05	—	
	Voltage gain		$G_V$ (ST)	1	$V_{in}$ = 200 mVrms (MONO)	-2	-0.6	1	dB
	Channel balance		C.B.	1	$V_{in}$ = 200 mVrms (MONO)	-1.5	0	1.5	dB
	Stereo LED sensitivity	ON	$V_L$ (ON)	1	Pilot input	—	10	16	mVrms
		OFF	$V_L$ (OFF)	1		4	8	—	
	Stereo LED hysteresis		$V_H$	1	to LED turn-off form LED turn-on	—	2	—	mVrms
	Capture range		C.R	1	P = 20 mVrms	—	±4.5	—	%
Signal to noise ratio		S/N (ST)	1	$V_{in}$ = 200 mVrms (MONO)	—	80	—	dB	
VCO frequency		$f_{vco}/12$	1	Specified when SW <sub>4</sub> = ON, MPX VCO/12	-300	19 k	+300	Hz	

## Test Circuit 1

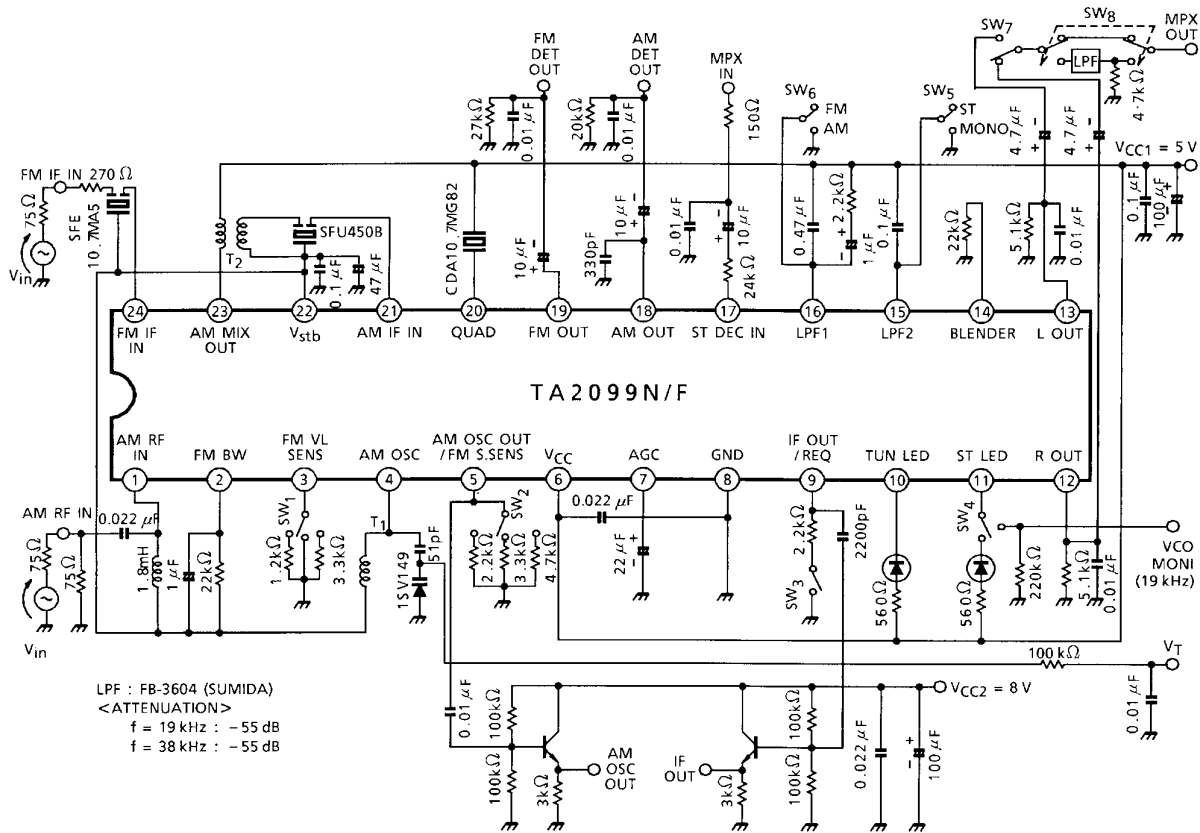

### Coil Data (Test Circuit 1)

Coil No.	f	L ( $\mu$ H)	C <sub>0</sub> (pF)	Q <sub>0</sub>	Turn				Wire (mm $\phi$ )	Ref. (Coil No.)
					1-2	2-3	1-3	4-6		
T <sub>1</sub> AM OSC	796 kHz	120	—	120	13	56	—	—	0.07 UEW	S: 2157-2239-779 T: A7BRS-12552Y M: MJ-3273-3
T <sub>2</sub> AM IFT	455 kHz	—	330	100	—	—	110	6	0.08 UEW	S: 4140-1289-311 T: 7MES-11368N M: MJ-3337-1

S: SUMIDA ELECTRIC Co., Ltd.  
 T: TOKO Co., Ltd.  
 M: MITSUMI ELECTRIC Co., Ltd.

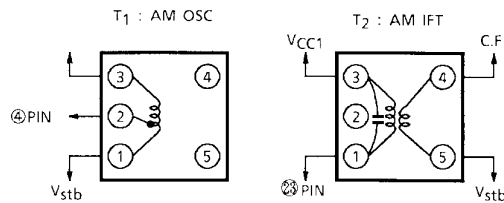

## Test Circuit 2

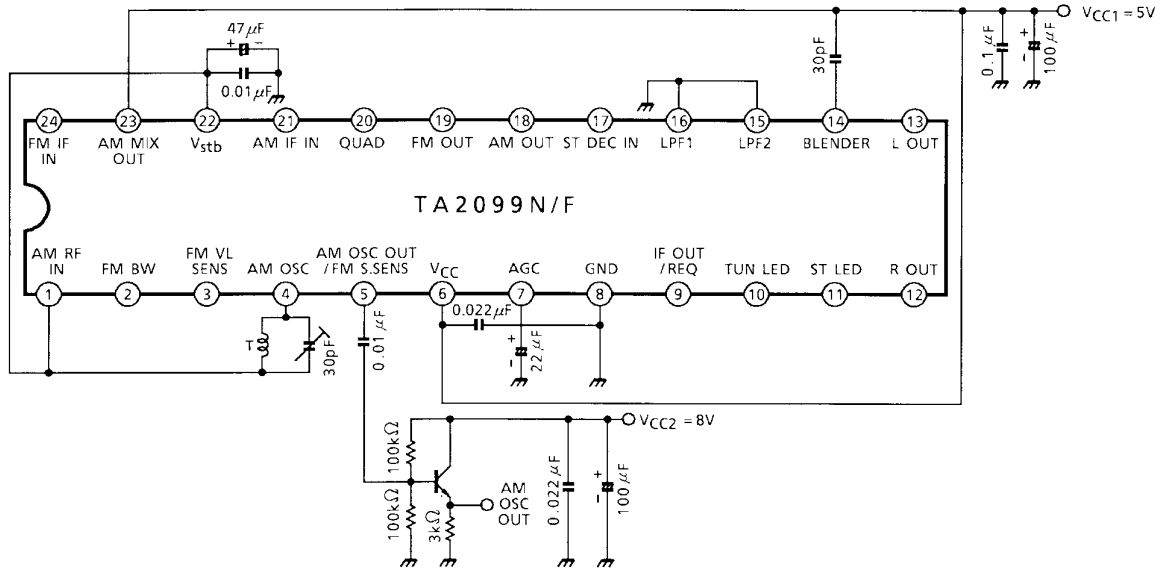

### Coil Data (Test Circuit 2)

Coil No.	f	L (μH)	C <sub>0</sub> (pF)	Q <sub>0</sub>	Turn				Wire (mmφ)	Ref. (Coil No.)
					1-2	2-3	1-3	4-6		
T AM OSC	7.96 MHz	1.4	—	84	1	6	7	—	0.08 UEW	T: 7PL-1344Y

T: TOKO Co., Ltd.

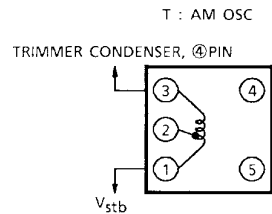

### FM MONO

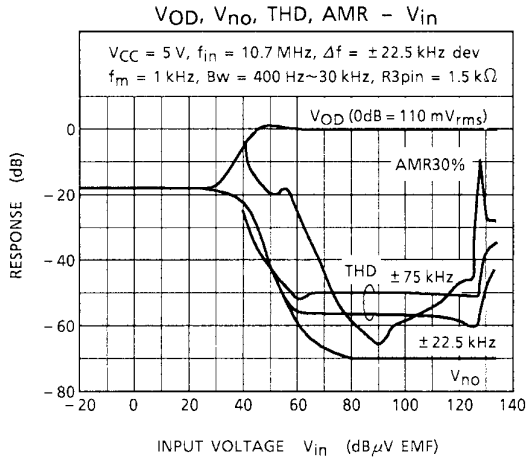

### FM ST (Main)

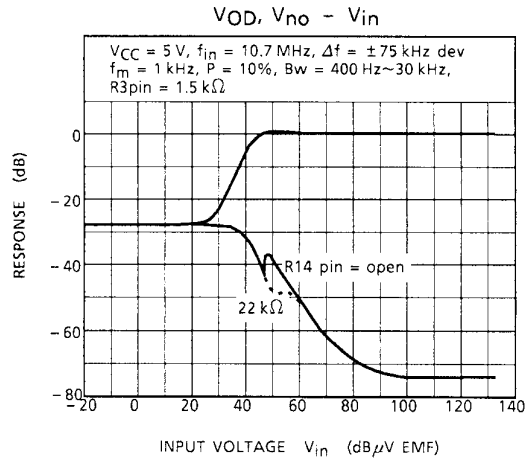

### FM

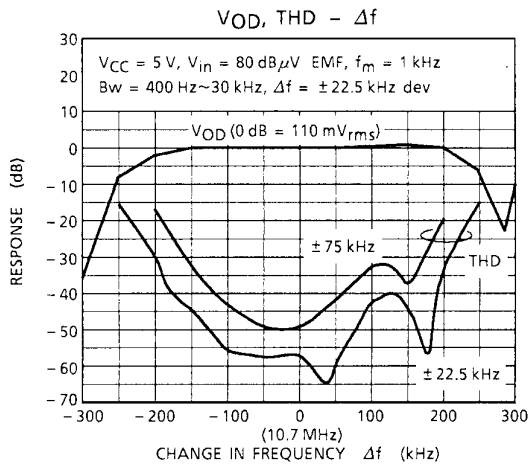

### FM

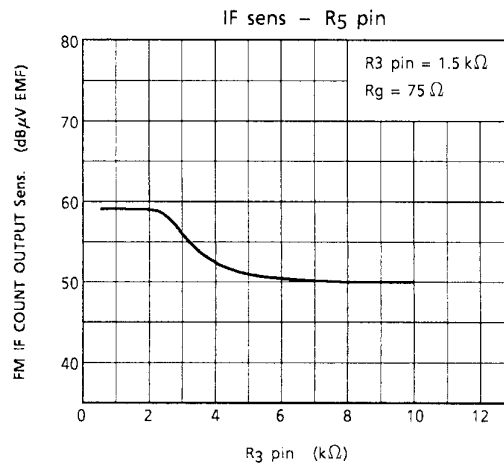
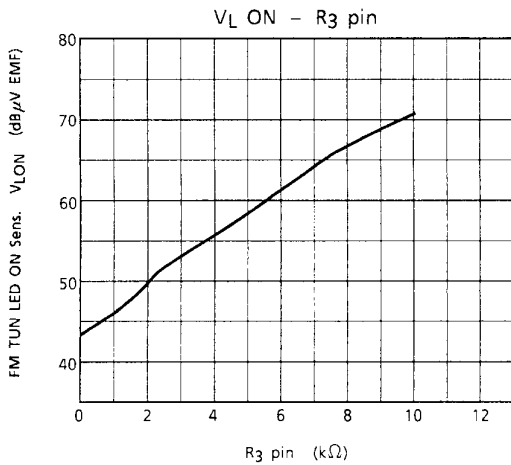
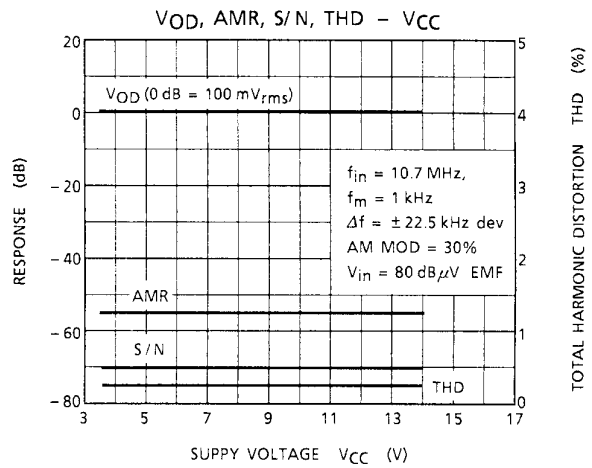

FM

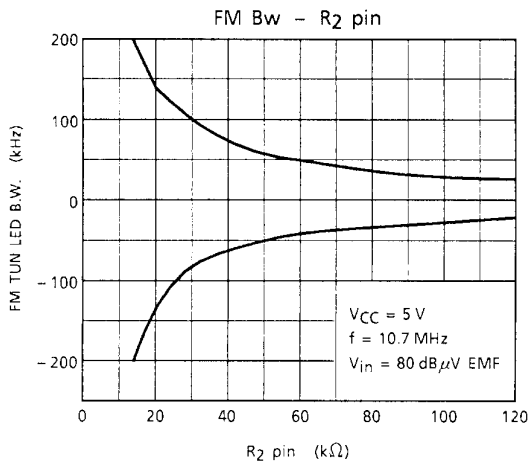

FM

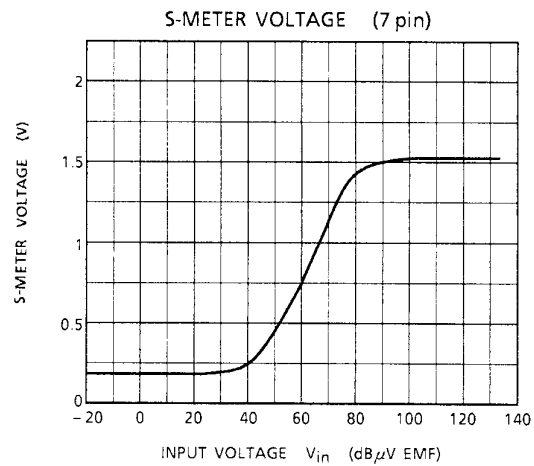

FM

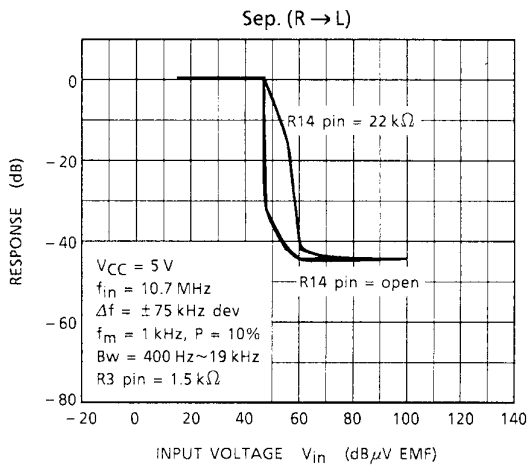

FM

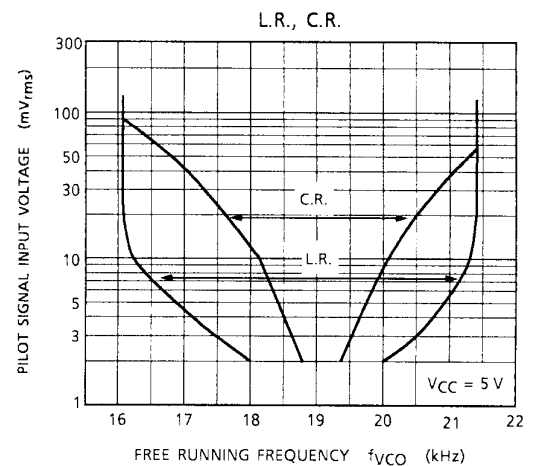

FM

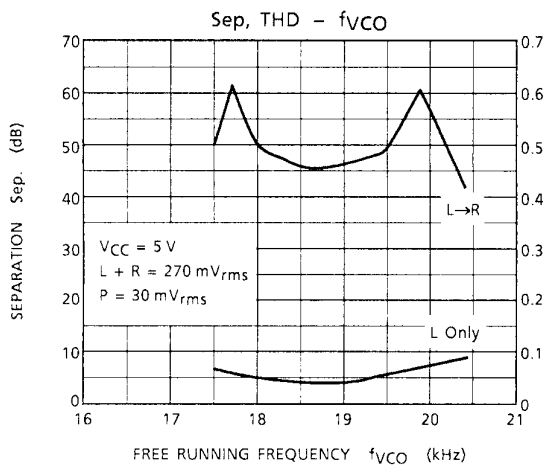

FM

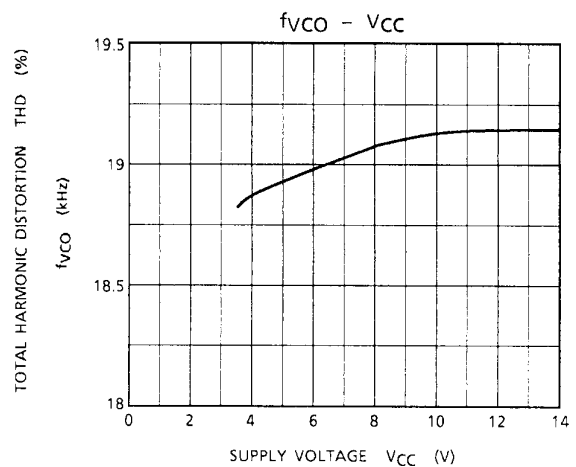

FM

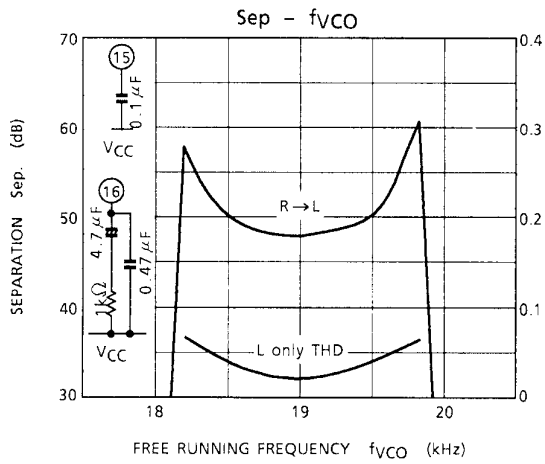

FM

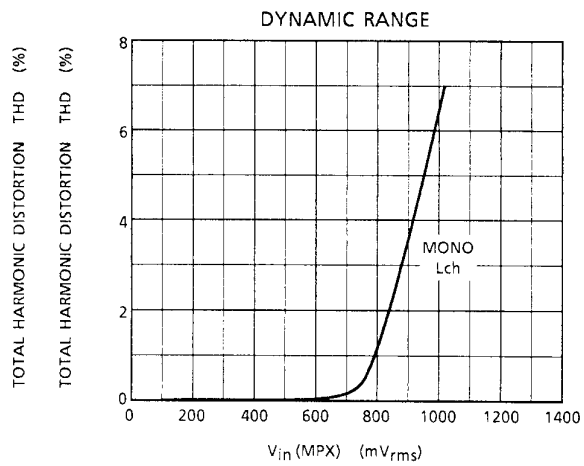

AM LINE INPUT

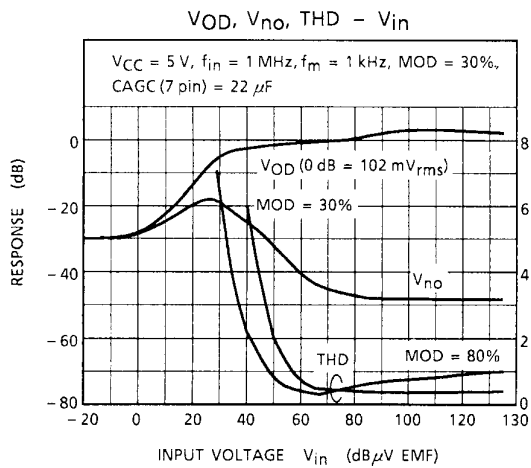

AM LINE INPUT

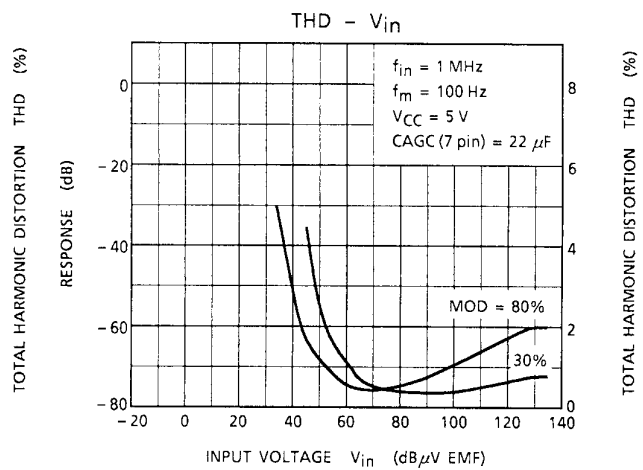



## Package Dimensions

SDIP24-P-300-1.78

Unit : mm

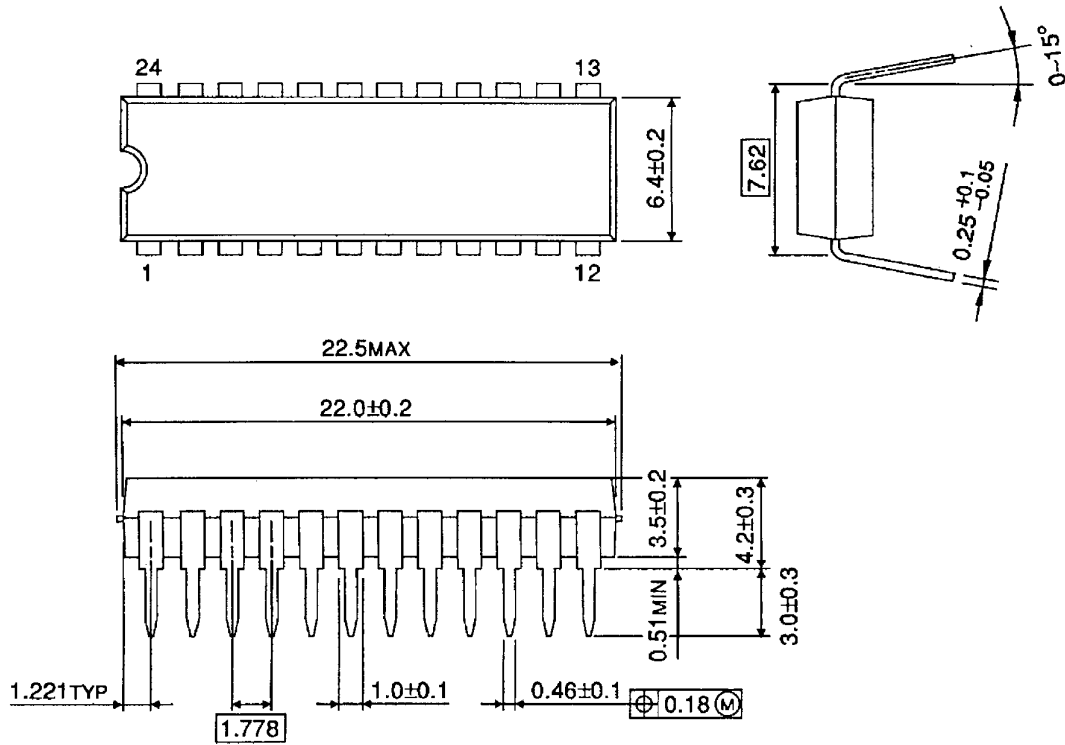

Weight: 1.2 g (typ.)

**Package Dimensions**

SSOP24-P-300-1.00

Unit : mm

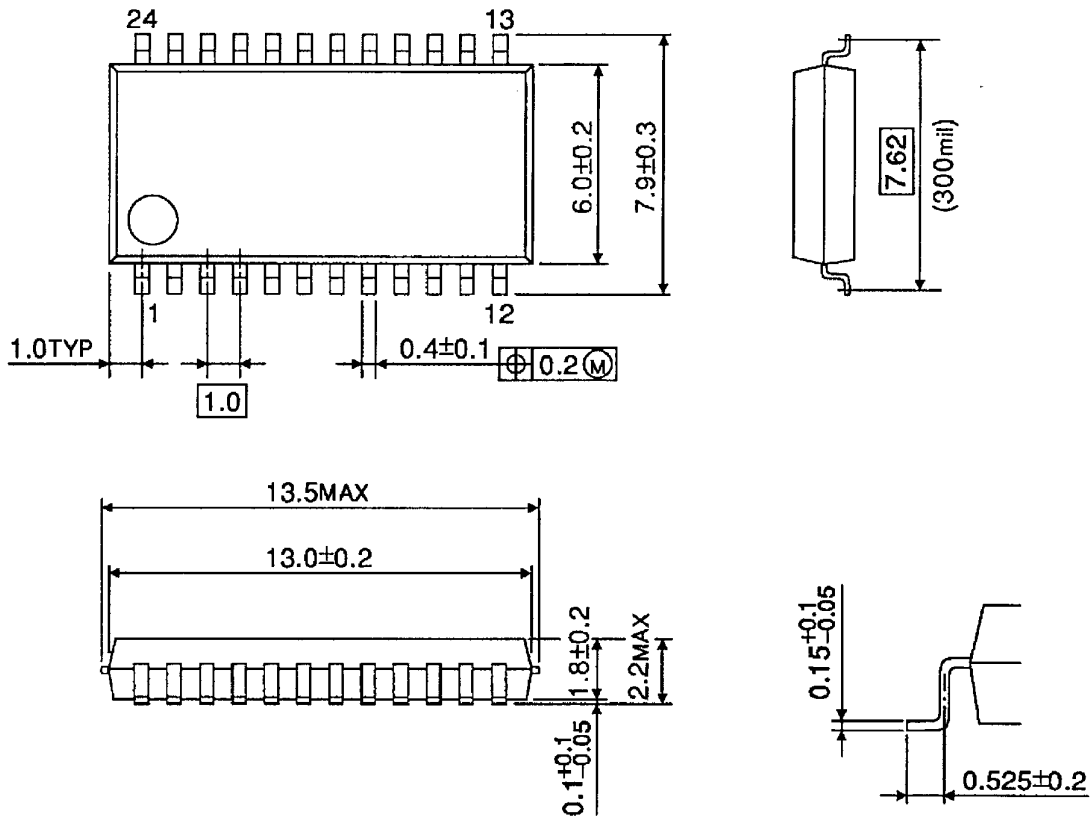

Weight: 0.31 g (typ.)

**RESTRICTIONS ON PRODUCT USE**

000707EBA

- TOSHIBA is continually working to improve the quality and reliability of its products. Nevertheless, semiconductor devices in general can malfunction or fail due to their inherent electrical sensitivity and vulnerability to physical stress. It is the responsibility of the buyer, when utilizing TOSHIBA products, to comply with the standards of safety in making a safe design for the entire system, and to avoid situations in which a malfunction or failure of such TOSHIBA products could cause loss of human life, bodily injury or damage to property.  
In developing your designs, please ensure that TOSHIBA products are used within specified operating ranges as set forth in the most recent TOSHIBA products specifications. Also, please keep in mind the precautions and conditions set forth in the "Handling Guide for Semiconductor Devices," or "TOSHIBA Semiconductor Reliability Handbook" etc..
- The TOSHIBA products listed in this document are intended for usage in general electronics applications (computer, personal equipment, office equipment, measuring equipment, industrial robotics, domestic appliances, etc.). These TOSHIBA products are neither intended nor warranted for usage in equipment that requires extraordinarily high quality and/or reliability or a malfunction or failure of which may cause loss of human life or bodily injury ("Unintended Usage"). Unintended Usage include atomic energy control instruments, airplane or spaceship instruments, transportation instruments, traffic signal instruments, combustion control instruments, medical instruments, all types of safety devices, etc.. Unintended Usage of TOSHIBA products listed in this document shall be made at the customer's own risk.
- The products described in this document are subject to the foreign exchange and foreign trade laws.
- The information contained herein is presented only as a guide for the applications of our products. No responsibility is assumed by TOSHIBA CORPORATION for any infringements of intellectual property or other rights of the third parties which may result from its use. No license is granted by implication or otherwise under any intellectual property or other rights of TOSHIBA CORPORATION or others.
- The information contained herein is subject to change without notice.