

# 5-channel BTL driver for CD and MD Players

## BA6996FP

The BA6996FP, an IC designed for CD and MD players, has a 5-channel BTL power driver and a standard operational amplifier. The spindle and tray driver share a single output buffer, and are specified with a control pin. In addition, the internal level shift circuit reduces the number of attached components.

### ●Applications

CD players, CD-ROM drives, MD players and other optical disc devices

### ●Features

- 1) A 5-channel BTL driver in a HSOP 28-pin package, allowing for application miniaturization.
- 2) Five drivers are turned on and off according to the combination of control pin logic.
- 3) The tray driver operates even when the servo power supply drops.
- 4) Internal thermal shutdown circuit.
- 5) Gain is adjustable with an attached resistor.
- 6) Internal standard operational amplifier.
- 7) Supports low-voltage servos.

### ●Absolute maximum ratings (Ta = 25°C)

Parameter	Symbol	Limits	Unit
Power supply voltage	V <sub>CC</sub>	18	V
Power dissipation	P <sub>d</sub>	1.7*	W
Operating temperature	T <sub>opr</sub>	-35~+85	°C
Storage temperature	T <sub>stg</sub>	-55~+150	°C

\* Reduced by 13.6 mW for each increase in Ta of 1°C over 25°C.  
When mounted on a 50 × 50 × 1mm paper phenol PCB board.

### ●Recommended operating conditions (Ta = 25°C)

Parameter	Symbol	Min.	Typ.	Max.	Unit
Power supply voltage	V <sub>CC</sub>	4.8	—	12	V

●Block diagram

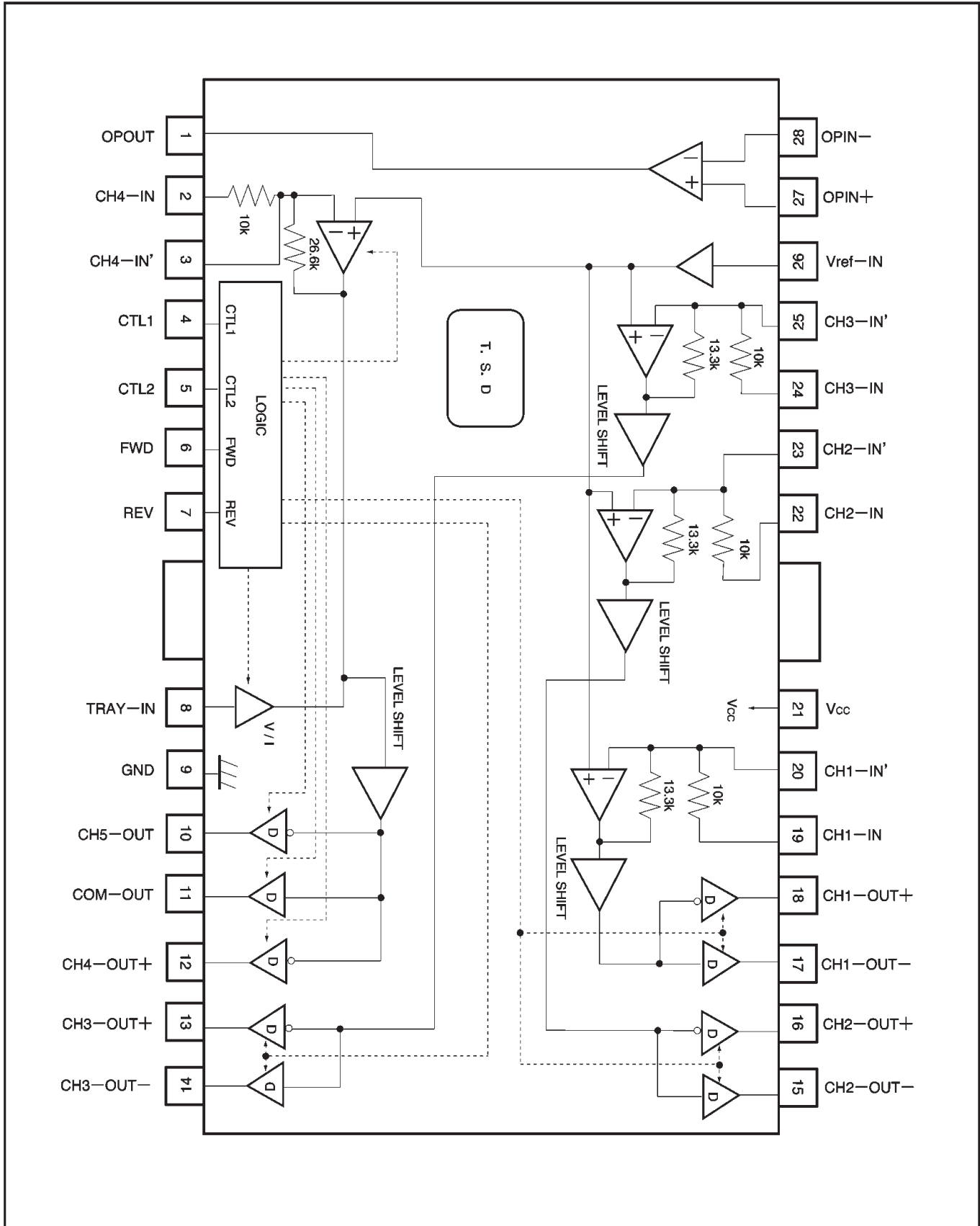

## ● Pin descriptions

Pin No.	Pin name	Function
1	OPOUT	Operational amplifier output
2	CH4-IN	Channel 4 input
3	CH4-IN'	Channel 4 gain adjustment input
4	CTL1	Control 1 input
5	CTL2	Control 2 input
6	FWD	Tray forward input
7	REV	Tray reverse input
8	TRAY-IN	Tray input
9	GND	Substrate ground
10	CH5-OUT-	Tray negative output
11	COM-OUT	Tray positive output/channel 4 negative output
12	CH4-OUT+	Channel 4 positive output
13	CH3-OUT+	Channel 3 positive output
14	CH3-OUT-	Channel 3 negative output
15	CH2-OUT-	Channel 2 negative output
16	CH2-OUT+	Channel 2 positive output
17	CH1-OUT-	Channel 1 negative output
18	CH1-OUT+	Channel 1 positive output
19	CH1-IN	Channel 1 input
20	CH1-IN'	Channel 1 gain adjustment input
21	V <sub>CC</sub>	V <sub>CC</sub>
22	CH2-IN	Channel 2 input
23	CH2-IN'	Channel 2 gain adjustment input
24	CH3-IN	Channel 3 input
25	CH3-IN'	Channel 3 gain adjustment input
26	V <sub>ref</sub> -IN	Bias amplifier input
27	OPIN+	Operational amplifier non-inverted input
28	OPIN-	Operational amplifier inverted input

\* Positive and negative output is relative to the polarity of the input pins. (For example, pin 18 output is HIGH when pin 19 output is LOW.)

● Input/output circuits

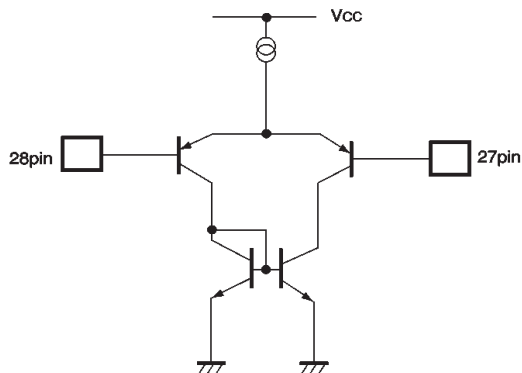
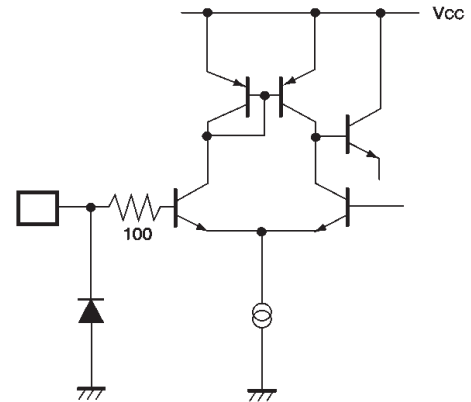
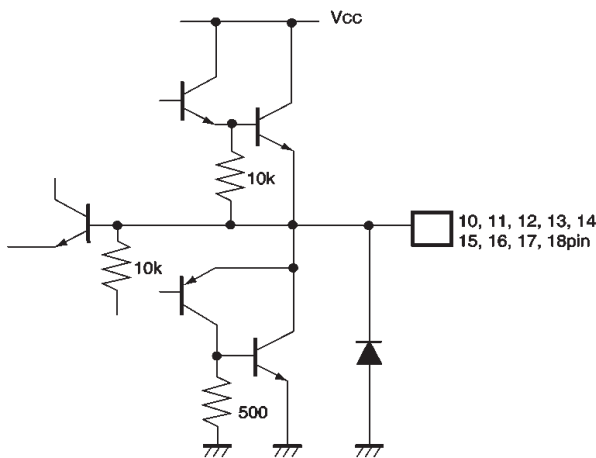
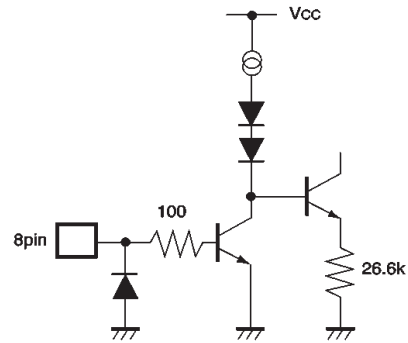
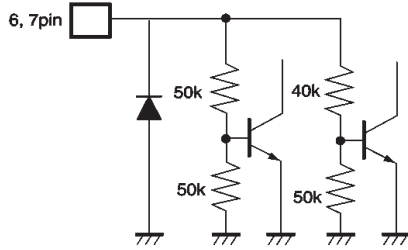
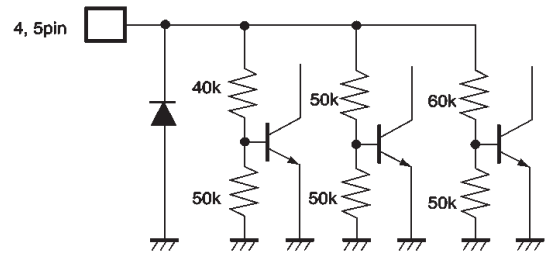
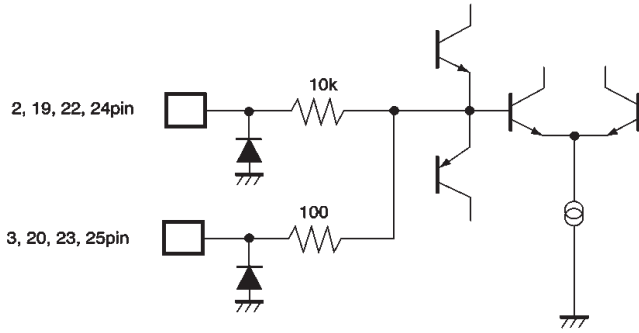

●Electrical characteristics (unless otherwise noted,  $T_a = 25^\circ\text{C}$ ,  $V_{CC} = 8\text{V}$ ,  $f = 1\text{kHz}$ ,  $R_L = 8\Omega$ )

Parameter	Symbol	Min.	Typ.	Max.	Unit	Conditions
Quiescent current dissipation	$I_{CC}$	8.5	11.5	14.5	mA	No load
Output voltage 1, offset	$V_{OO}$	-40	-	40	mV	Channel 1 to 3
Output voltage 2, offset	$V_{OO}$	-100	-	100	mV	Channel 4
Maximum output pin voltage 1	$V_{OHD1}$	3.7	4.3	-	V	$V_{IN} = V_{CC}$
Maximum output pin voltage 2	$V_{OHD2}$	-	-4.3	-3.7	V	$V_{IN} = \text{GND}$
Closed loop voltage gain 1	$G_{VC1}$	6.5	8.0	9.5	dB	$V_{IN} = 0.1V_{rms}$ , 1kHz (excluding channel4)
Closed loop voltage gain 2	$G_{VC2}$	11.5	14.0	16.5	dB	$V_{IN} = 0.1V_{rms}$ , 1kHz (channel4)
Ripple rejection	RR	-	60	-	dB	$V_{IN} = 0.1V_{rms}$ , 100Hz
Slew rate	SR	-	2.0	-	V/ $\mu\text{s}$	100 Hz square wave, 3 $V_{P-P}$ output
〈Tray driver〉						
Output voltage F	$V_{OF}$	2.5	3.0	3.5	V	Pin 8 voltage=3 V
Output voltage R	$V_{OR}$	-3.5	-3.0	-2.5	V	Pin 8 voltage=3 V
Output voltage range F	$V_{OMF}$	3.7	4.3	-	V	Pin 8 voltage=5 V
Output voltage range R	$V_{OMR}$	-	-4.3	-3.7	V	Pin 8 voltage=5 V
Load regulation F	$\Delta V_{FI}$	-	250	500	mV	$I_L = 100\text{-}400\text{ mA}$ , pin 8 voltage = 2.5 V
Load regulation R	$\Delta V_{RI}$	-	250	500	mV	$I_L = 100\text{-}400\text{ mA}$ , pin 8 voltage = 2.5 V
Line regulation F	$\Delta V_{FL}$	-	300	600	mV	$V_{CC} = 5\text{V} \sim 12\text{V}$
Line regulation R	$\Delta V_{RL}$	-	300	600	mV	$V_{CC} = 5\text{V} \sim 12\text{V}$
Output voltage, offset	$V_{OOL}$	-50	-	50	mV	Braking, output voltage
〈Logic: CT1, CTL2, FWD and REV〉						
Input high level voltage	$V_{IH}$	2.0	-	8.0	V	Maximum: $V_{CC}$
Input low level voltage	$V_{IL}$	-0.3	-	0.5	V	
Input high level current	$I_{IH}$	-	-	500	$\mu\text{A}$	
Input low level current	$I_{IL}$	-	-	500	$\mu\text{A}$	
〈Operational amplifier〉						
Offset voltage	$V_{OFOP}$	-5	0	5	mV	
Input bias current	$I_{BIAS}$	-	-	300	nA	
Output high level voltage	$V_{OHOP}$	6.0	-	-	V	
Output low level voltage	$V_{OLOP}$	-	-	1.1	V	
Output drive current (source)	$I_{OSO}$	10	40	-	mA	GND at 50 $\Omega$
Output drive current (sink)	$I_{OSI}$	10	50	-	mA	$V_{CC}$ at 50 $\Omega$
Open loop voltage gain	$G_{VO}$	-	78	-	dB	$V_{IN} = -75\text{dBV}$ , 1kHz
Slew rate	$SR_{OP}$	-	1	-	V/ $\mu\text{s}$	100 Hz square wave, 4 $V_{P-P}$ output
Ripple rejection	$RR_{OP}$	-	65	-	dB	$V_{IN} = 0.1V_{rms}$ , 100Hz
Synchronous signal rejection	CMRR	-	84	-	dB	$V_{IN} = 0.1V_{rms}$ , 1kHz

◎ Not designed for radiation resistance.

● Measurement circuit

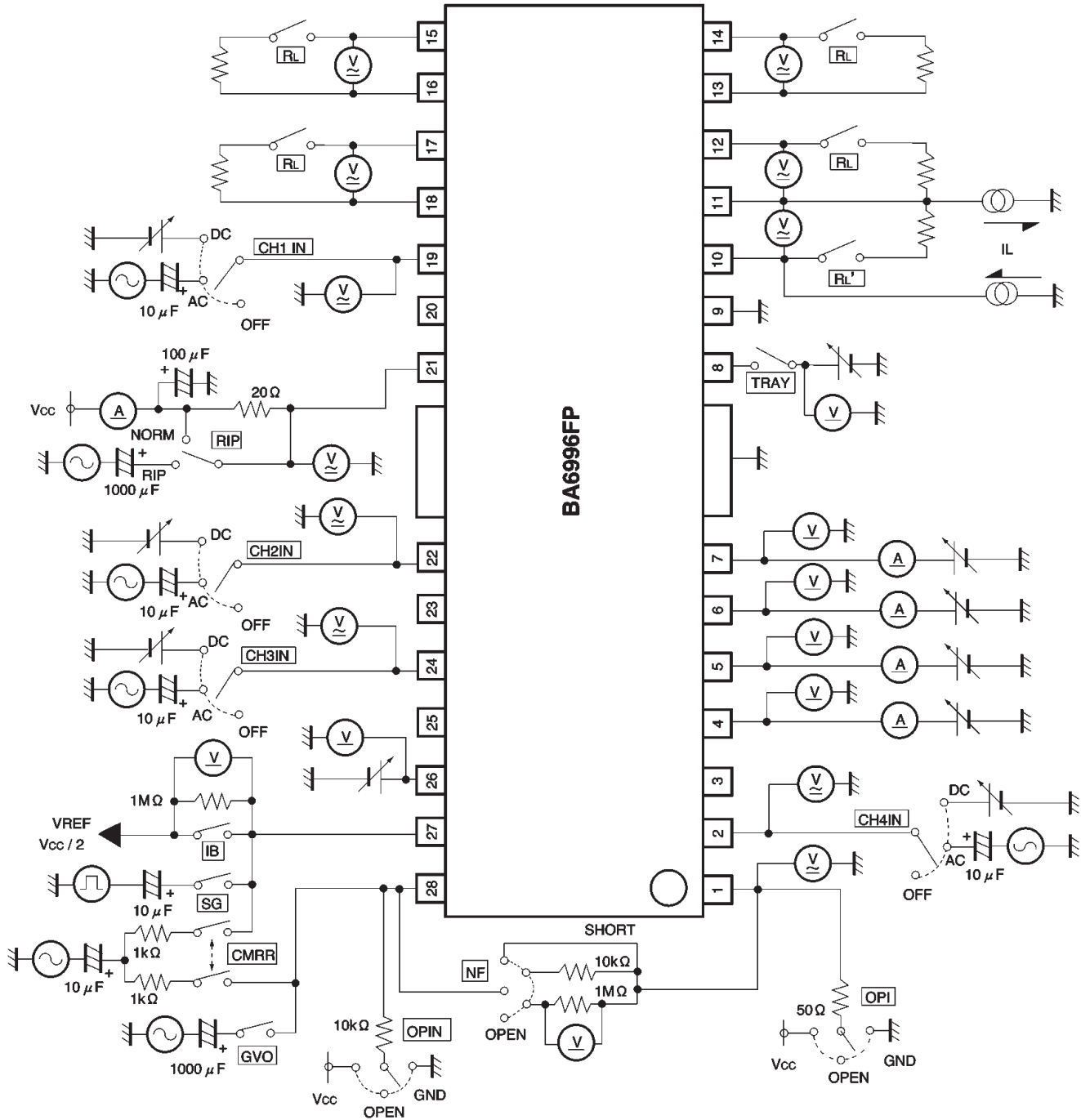

Fig.1

●Application example

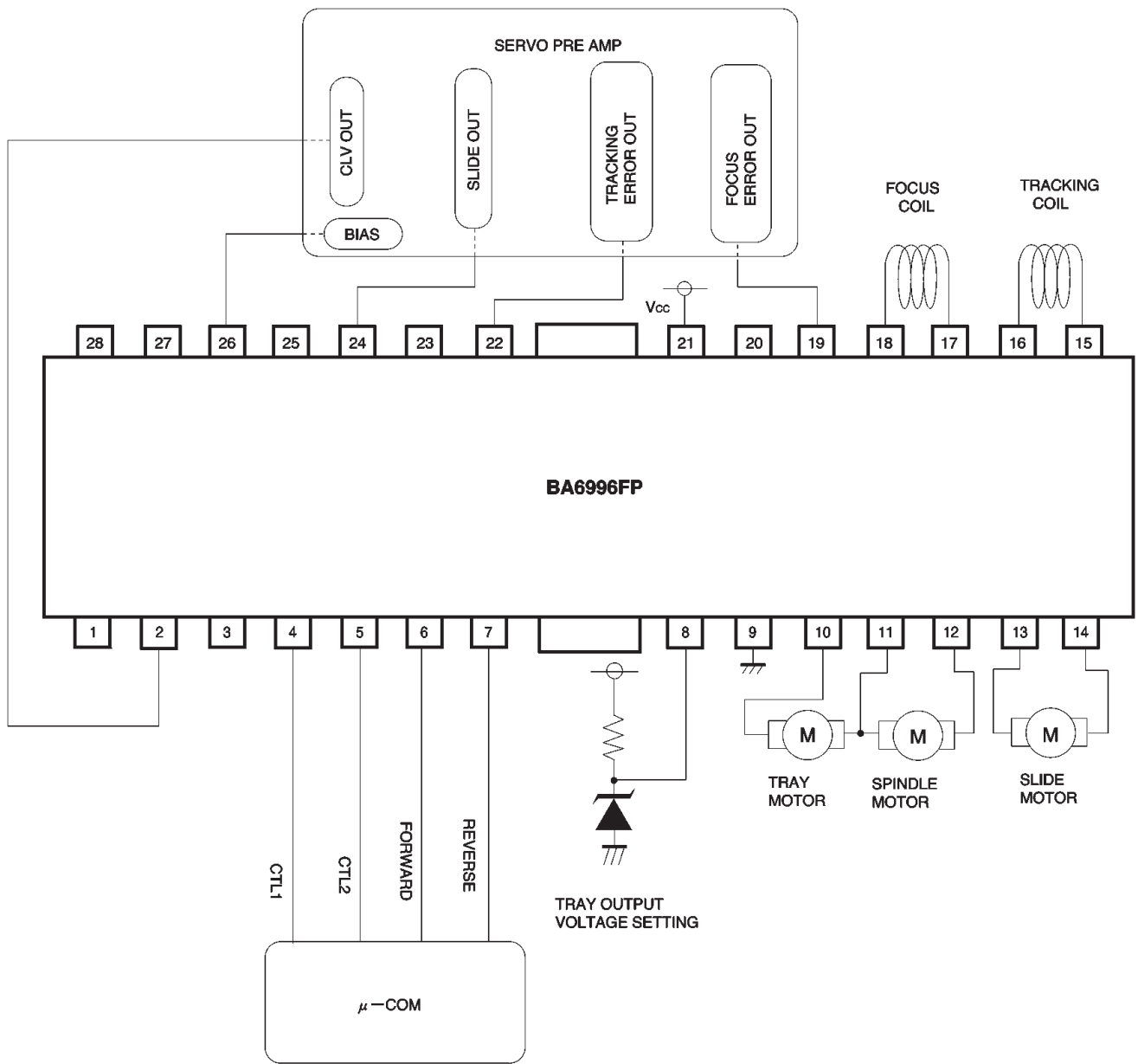

Fig.2

● Operation notes

(1) Setting the tray motor driver voltage (forward mode)

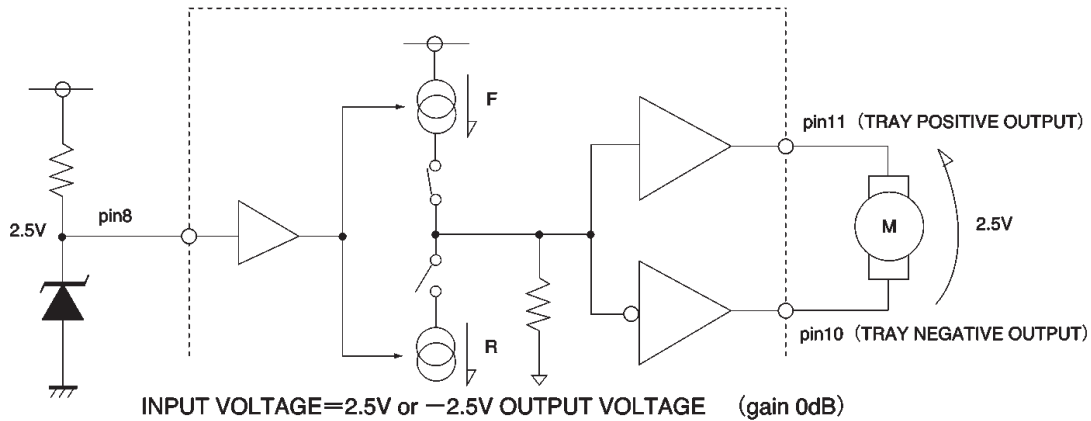

Fig. 3

Note: The tray driver will not exceed the power supply's maximum output voltage, even if set above this maximum voltage (refer to the following page). The example above applies only when setting below the maximum output voltage. Maximum output voltage for the power supply can be output by pulling up the tray input pin (pin 8) or by connecting it to Vcc.

(2) Mute functions

Mute function	Muted channels
Thermal shutdown	All channels
Muting during supply voltage drop	All channels
Muting during bias voltage drop	channel1 to 4

«Thermal shutdown»

The output current is muted when the chip temperature exceeds 175°C (typically).

«Supply voltage drop muting»

The internal circuits turn off when the supply voltage drops below 4.3V (typically), and turn on again when it rises above 4.5V (typically).

(3) Muting occurs during thermal shutdown and when the supply voltage or bias pin voltage drops. In each case, only the driver is muted. The output pin voltage during muting is the internal bias voltage, roughly  $V_{CC}-VF/2$ .

(4) Be sure to connect the IC to a 0.1μF bypass capacitor to the power supply, at the base of the IC.

(5) Connect the radiating fin to an external ground.



●Electrical characteristic curves

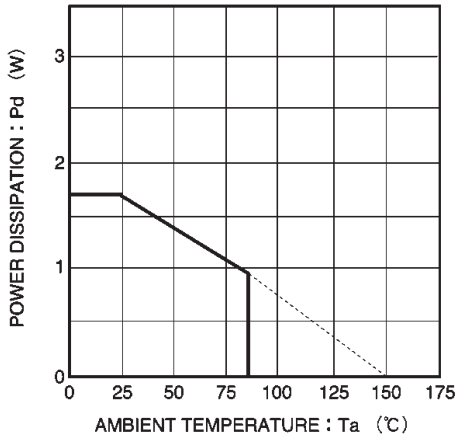

Fig. 4 Thermal derating curve

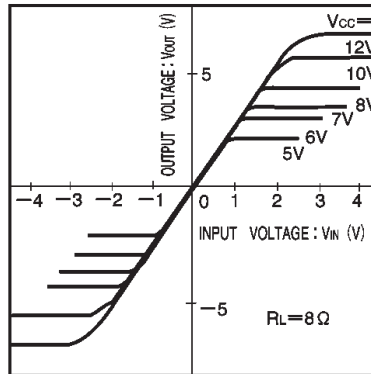

Fig. 5 Driver CH1-3 I / O characteristics (when changing power supply voltage)

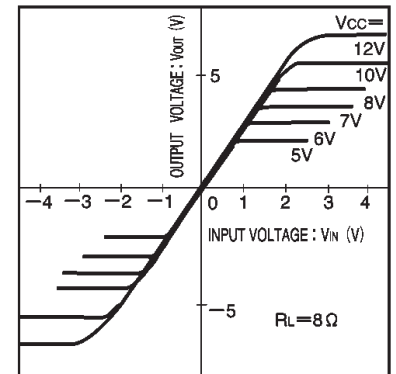

Fig. 6 Driver CH4 I / O characteristics (when changing power supply voltage)

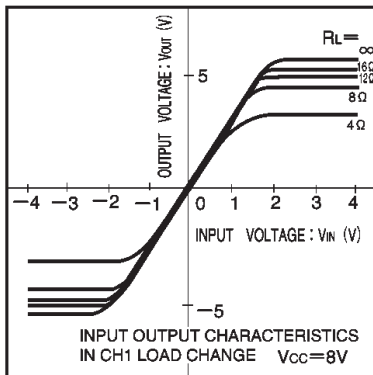

Fig. 7 Driver CH1-3 I / O characteristics (when load changes)

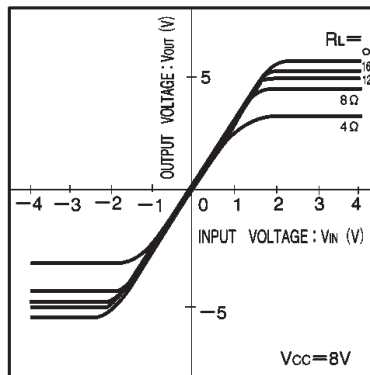

Fig. 8 Driver CH4 I / O characteristics (when load changes)

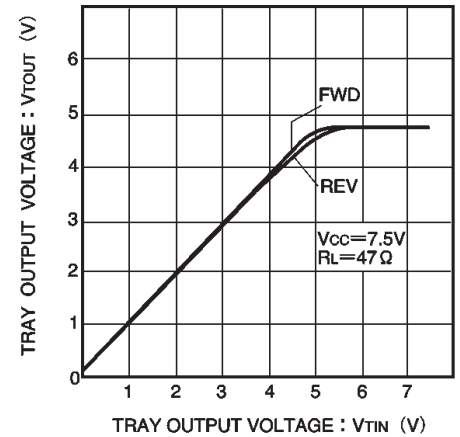

Fig. 9 Tray driver I / O characteristics

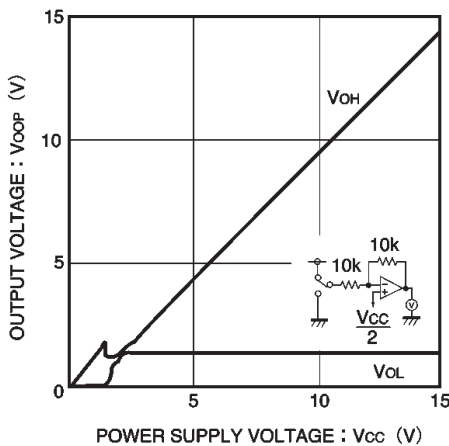

Fig. 10 Power supply voltage vs. high / low output voltage

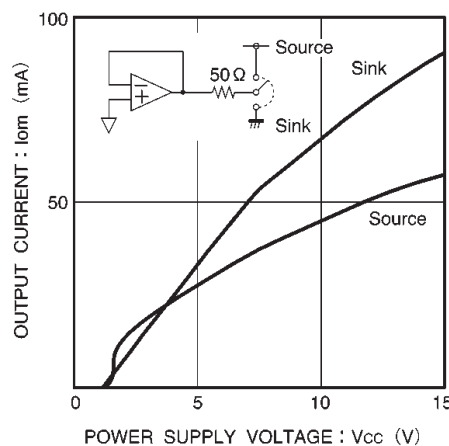
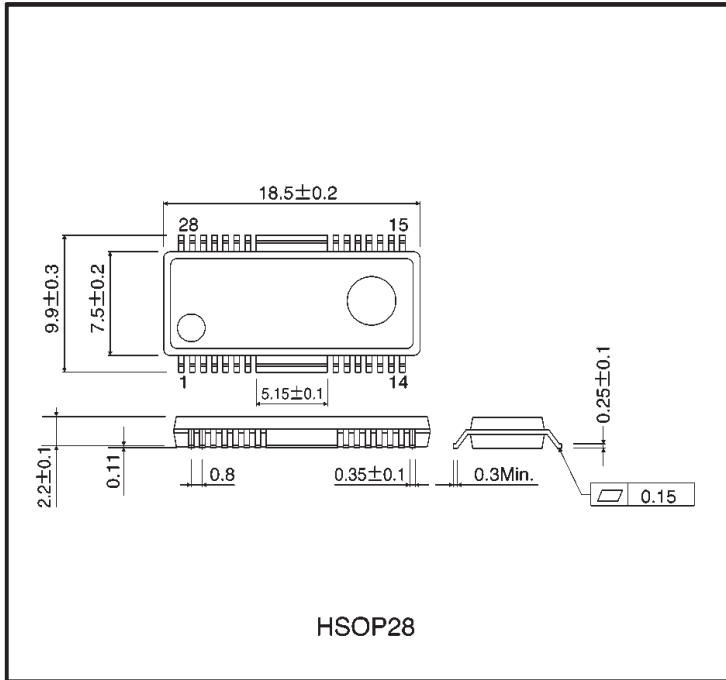

Fig. 11 Power supply voltage vs. operational amplifier output operating current

● External dimensions (Units: mm)



# MEMO