

# Spindle and loading motor driver for PD BA6852FP

The BA6852FP is a motor driver IC developed for use in PD, CD-ROM and DVD applications. In addition to having a conventional spindle motor driver, it includes a reversible motor driver for use with loading motors to allow easy system construction.

## ●Applications

PD, CD-ROM and DVD.

## ●Features

- 1) Power save circuit (three-level switch) allows FG output in power save mode.
- 2) FGSW allows selection between either three-phase composite output or single-phase output for the FG output.
- 3) The output voltage for the loading motor driver can be set using the Vref pin.

## ●Absolute maximum ratings (Ta = 25°C)

Parameter	Symbol	Limits	Unit
Applid voltage	Vcc	7	V
Applid voltage	V <sub>M1,2</sub>	15	V
Power dissipation	Pd	1700*1	mW
Operating temperature	Topr	-20~+75	°C
Storage temperature	Tstg	-55~+150	°C
Junction temperature	Tjmax	150	°C
Output current (spindle block) (loading block)	I <sub>OMAX</sub>	1300*2 1000	mW

\*1 When mounted on 70mm×70mm ×1.6mm glass epoxy board.  
Reduced by 13.6mW for each increase in Ta of 1°C over 25°C.

\*2 Should not exceed Pd or ASO values.

## ●Recommended operating conditions (Ta = 25°C)

Parameter	Symbol	Limits	Unit
Power supply voltage (spindle block motor power supply) (loading block motor power supply)	Vcc	4.5~5.5	V
	V <sub>M1</sub>	3~14	V
	V <sub>M2</sub>	4.5~14	V

●Block diagram

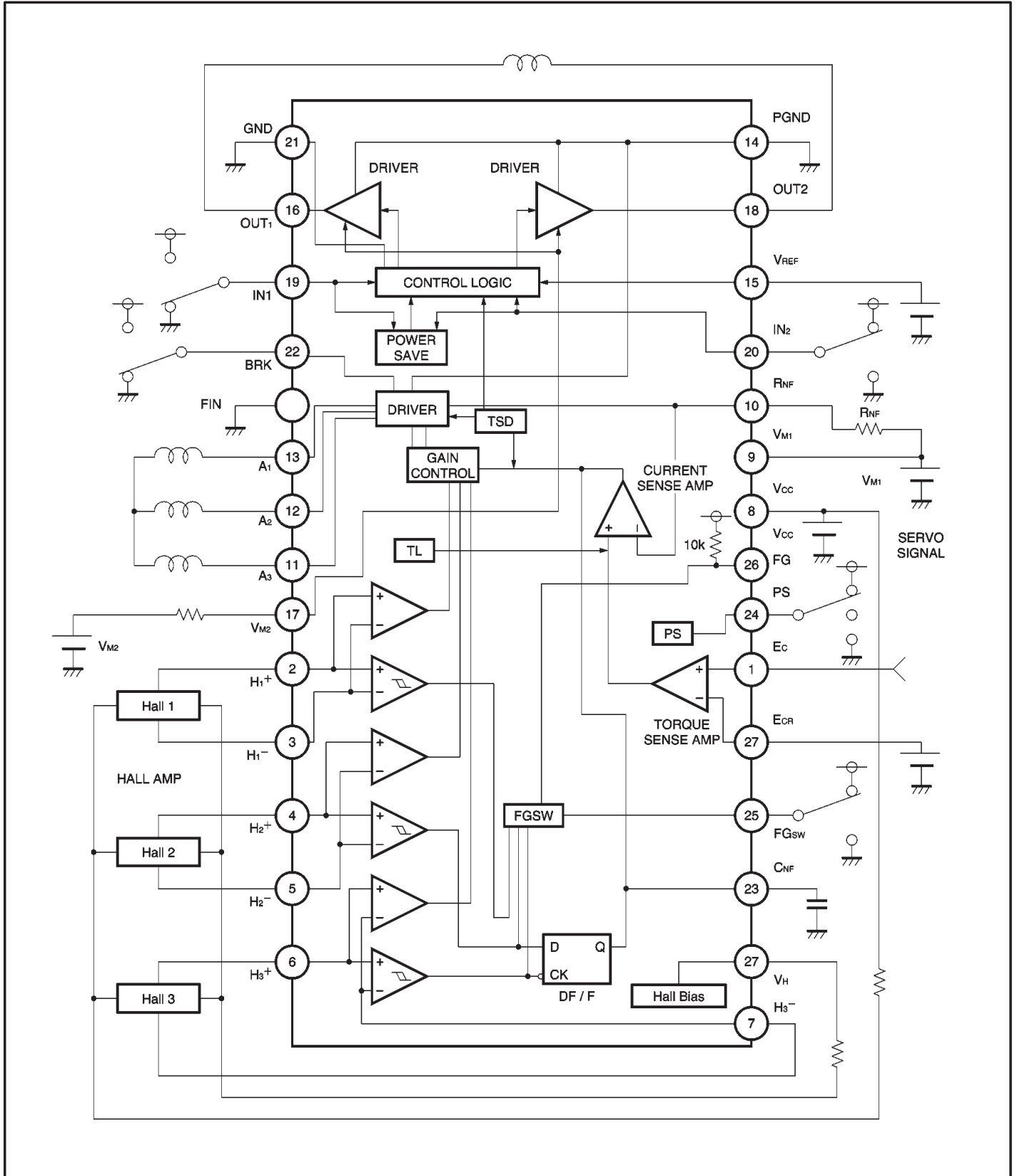

## ●Pin descriptions

Pin No.	Pin name	Function
1	Ec	Spindle torque control
2	H <sub>1</sub> <sup>+</sup>	Hall signal input pin spindle
3	H <sub>1</sub> <sup>-</sup>	Hall signal input pin spindle
4	H <sub>2</sub> <sup>+</sup>	Hall signal input pin spindle
5	H <sub>2</sub> <sup>-</sup>	Hall signal input pin spindle
6	H <sub>3</sub> <sup>+</sup>	Hall signal input pin spindle
7	H <sub>3</sub> <sup>-</sup>	Hall signal input pin spindle
8	V <sub>CC</sub>	Signal block power supply
9	V <sub>M1</sub>	Spindle motor power supply
10	R <sub>NF</sub>	For connection of resistor for spindle output current detector
11	A <sub>3</sub>	Spindle output A3
12	A <sub>2</sub>	Spindle output A2
13	A <sub>1</sub>	Spindle output A1
14	PGND	Driver GND
15	V <sub>REF</sub>	Loading output high level voltage setting
16	OUT1	Loading motor output 1
17	V <sub>M2</sub>	Loading motor power supply
18	OUT2	Loading motor output 2
19	IN1	Loading logic input
20	IN2	Loading logic input
21	GND	Signal GND
22	BRK	Spindle brake
23	CNF	For connection of capacitor for spindle phase compensation
24	PS	Spindle power save
25	FGSW	Spindle FG output switch
26	FG	Spindle FG signal output
27	V <sub>H</sub>	Hall bias
28	E <sub>CR</sub>	Spindle torque control reference
FIN	FIN	Heatsink fin

\* The heatsink fin must be connected to GND.

●Electrical characteristics (unless otherwise noted, Ta = 25°C, VCC = 5V, VM1 = 12V, and VM2 = 12V)

Parameter	Symbol	Min.	Typ.	Max.	Unit	Coniditions	Measurement circuit
[Spindle]							
Circuit current 1	IC1	—	0.4	0.6	mA	Standby mode, IPS=−150 μA	Fig.3
Circuit current 2	IC2	—	2.8	4.0	mA	Only Hall bias and FG operates	Fig.3
Circuit current 3	IC3	—	5.7	8.0	mA	Operation mode, Ec=ECR	Fig.3
〈Power save〉							
On current range	IPSON	−350	—	−150	μA	Standby mode	Fig.4
Open current range	IPSOP	−15	—	15	μA	Only Hall bias and FG operates	Fig.4
Off current range	IPSOFF	150	—	350	μA	Operation mode	Fig.4
〈Hall bias〉							
Hall bias voltage	VHB	—	0.9	1.5	V	IHB=10mA	Fig.5
〈Hall amplifier〉							
Input bias current	IHA	—	0.7	2.0	μA	—	Fig.6
Same-phase input voltage range	VHAR	1.5	—	4.0	V	—	Fig.6
Minimum input level	VINH	50	—	—	mV <sub>P-P</sub>	—	Fig.6
Hall hysteresis	VHYS	5	20	40	mV	—	Fig.12
〈Torque command〉							
Input voltage range	Ec, ECR	1.0	—	4.0	V	—	Fig.7
Offset+	ECof +	20	50	80	mV	With respect to Ec=2.5V	Fig.7
Offset−	ECof −	−80	−50	−20	mV	—	Fig.7
Input bias current	ECIN	−3	−0.4	3	μA	Ec=2V, ECR=2.5V	Fig.7
I / O gain	GEC	0.4	0.5	0.6	A / V	Ec=1.5, 2.0V	Fig.7
〈Brake〉							
On voltage range	VSBON	3.5	—	—	V	Brake on mode	Fig.8
Off voltage range	VSOFF	—	—	1.5	V	Brake off mode	Fig.8
〈FG〉							
FGSW input low level voltage	VSWL	—	—	1.5	V	FG1 phase output	Fig.9
FGSW input high level voltage	VSWH	3.5	—	—	V	FG3 phase composition output	Fig.9
FG output high level voltage	VFGH	4.5	4.9	5.0	V	I <sub>FG</sub> =−10 μA	Fig.10
FG output low level voltage	VFGL	0	0.2	0.35	V	I <sub>FG</sub> =5.0mA	Fig.10
Duty (reference value)	Du	—	50	—	%	—	—
〈Output〉							
Output saturation high level voltage	VOH	—	1.0	1.5	V	I <sub>o</sub> =−600mA	Fig.11
Output saturation low level voltage	VOL	—	0.4	0.9	V	I <sub>o</sub> =600mA	Fig.11
VM drive current	I <sub>VMD</sub>	—	50	85	mA	Ec=0V Output open	Fig.12
Output limit current	I <sub>TL</sub>	560	700	840	mA	R <sub>NF</sub> =0.5 Ω	Fig.5

©Not designed for radiation resistance.

Parameter	Symbol	Min.	Typ.	Max.	Unit	Coniditions	Measurement circuit
[Loading block]							
Circuit current 4	$I_{cc4}$	12	24	36	mA	Forward or reverse mode	Fig.13
Circuit current 5	$I_{cc5}$	29	48	67	mA	IN1="H", IN2="H"	Fig.13
Input voltage high level	$V_{IH}$	2.1	—	—	V	—	Fig.13
Input voltage low level	$V_{IL}$	—	—	0.8	V	—	Fig.13
High level input voltage	$I_{IH}$	45	90	135	$\mu A$	$V_{IN}=2V$	Fig.13
Outout saturation voltage*	$V_{CE}$	—	1.0	1.5	V	$I_o=0.2A$	Fig.14
$V_{REF}$ pin outflow current	$I_{REF}$	—	2.0	5.0	$\mu A$	$I_o=0.1A, V_{REF}=9V$	Fig.15
$V_{REF}$ input voltage range	$V_{REF}$	—	—	$(V_{M2})-1$	V	—	Fig.15

\* The output saturation voltage is the sum of the upper and lower output Tr.  
 ©Not designed for radiation resistance.

● Measurement circuits

(1) Measurement circuit resistance

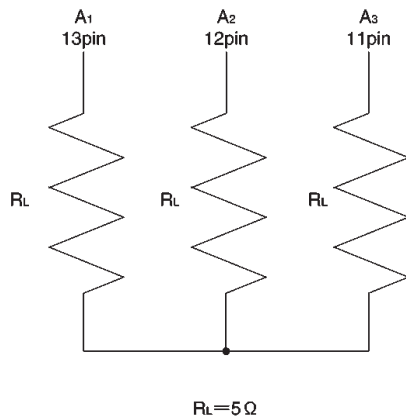

Fig.1

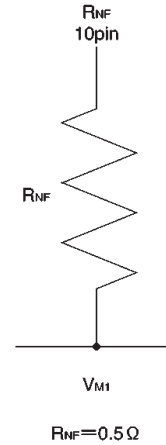

Fig.2

(2) Input/output table

Pin No.	Input conditions						Output state						Measurement point
							Forward			Reverse			
Pin Name	2	3	4	5	6	7	13	12	11	13	12	11	
	$H_1^+$	$H_1^-$	$H_2^+$	$H_2^-$	$H_3^+$	$H_3^-$	A1	A2	A3	A1	A2	A3	
Condition 1	L	M	H	M	M	M	H	L	L	L	H	H	13pin HIGH
Condition 2	H	M	L	M	M	M	L	H	H	H	L	L	13pin LOW
Condition 3	M	M	L	M	H	M	L	H	L	H	L	H	12pin HIGH
Condition 4	M	M	H	M	L	M	H	L	H	L	H	L	12pin LOW
Condition 5	H	M	M	M	L	M	L	L	H	H	H	L	11pin HIGH
Condition 6	L	M	M	M	H	M	H	H	L	L	L	H	11pin LOW

Note: Forward  $E_C < E_{CR}$   
 Reverse  $E_C > E_{CR}$

Input voltage H = 2.6V  
 M = 2.5V  
 L = 2.4V

(3) Measurement circuits

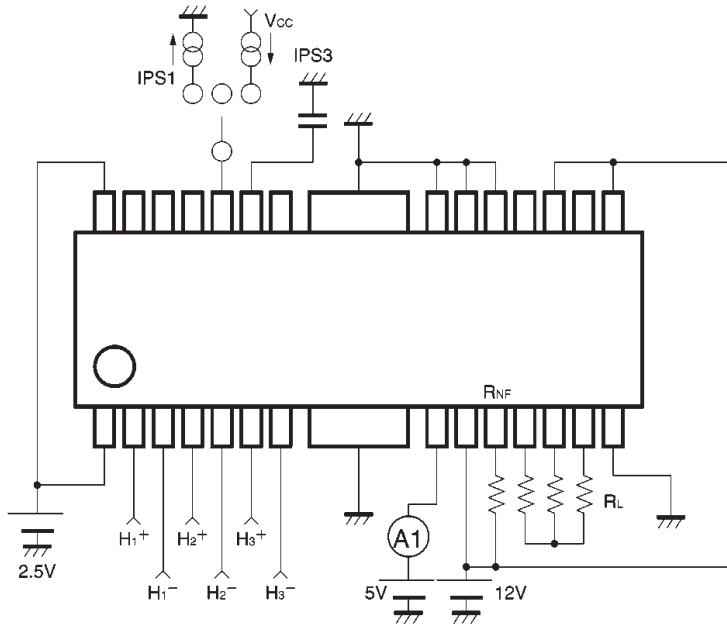

Fig.3

- I<sub>CC1</sub> : Ammeter A1 value  
 IPS1 = 150μA  
 H<sub>1</sub><sup>-</sup>, H<sub>2</sub><sup>-</sup>, H<sub>3</sub><sup>-</sup> = V<sub>CC</sub> / 2 (V)  
 H<sub>1</sub><sup>+</sup>, H<sub>2</sub><sup>+</sup>, H<sub>3</sub><sup>+</sup> = V<sub>CC</sub> / 2 + 0.1 (V)
- I<sub>CC2</sub> : Ammeter A1 value  
 PS = OPEN  
 H<sub>1</sub><sup>-</sup>, H<sub>2</sub><sup>-</sup>, H<sub>3</sub><sup>-</sup> = V<sub>CC</sub> / 2 (V)  
 H<sub>1</sub><sup>+</sup>, H<sub>2</sub><sup>+</sup>, H<sub>3</sub><sup>+</sup> = V<sub>CC</sub> / 2 + 0.1 (V)
- I<sub>CC3</sub> : Ammeter A1 value  
 IPS3 = 150μA  
 H<sub>1</sub><sup>-</sup>, H<sub>2</sub><sup>-</sup>, H<sub>3</sub><sup>-</sup> = V<sub>CC</sub> / 2 (V)  
 H<sub>1</sub><sup>+</sup>, H<sub>2</sub><sup>+</sup>, H<sub>3</sub><sup>+</sup> = V<sub>CC</sub> / 2 + 0.1 (V)

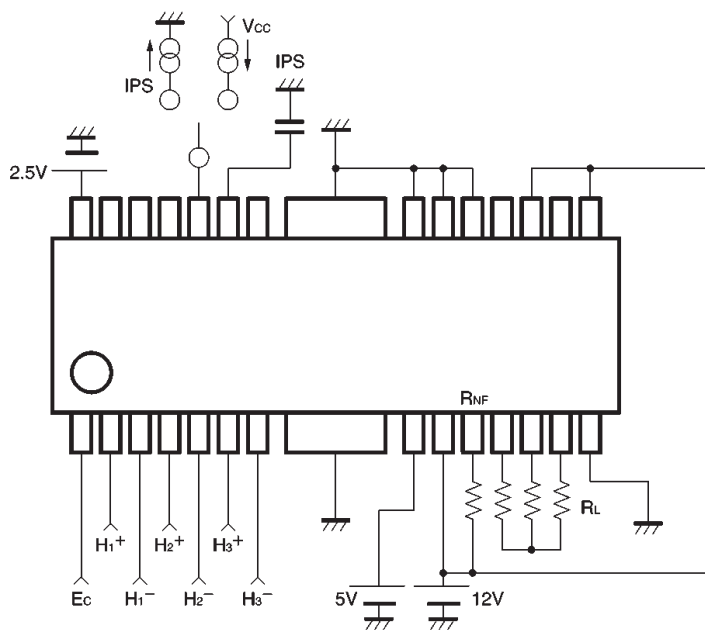

Fig.4

- I<sub>PSON</sub> : IPS range for which all output pins are open  
 (input conditions 1 to 6)
- I<sub>PSOP</sub> : IPS range for only FG and the hall bias operate  
 (input conditions 1 to 6)
- I<sub>PSOFF</sub> : PS range for which the output pins are as in the Input / output table  
 (input conditions 1 to 6)

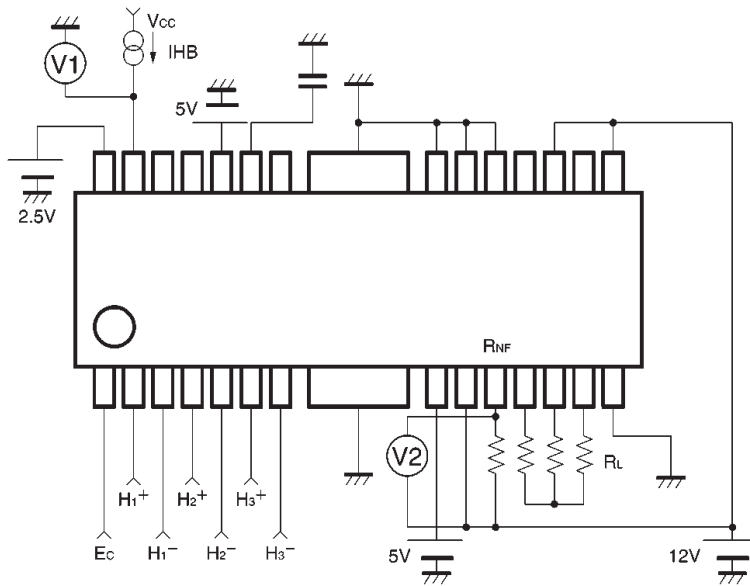

Fig.5

$V_{HB}$  : Voltmeter V1 value  
 $VPS = 5V$   
 $I_{HB} = 10mA$   
 $I_{TL}$  : (Voltmeter V2value) / 0.5  
 $VPS = 5V$   
 $E_c = 0V$   
 (input conditions 1 to 6)

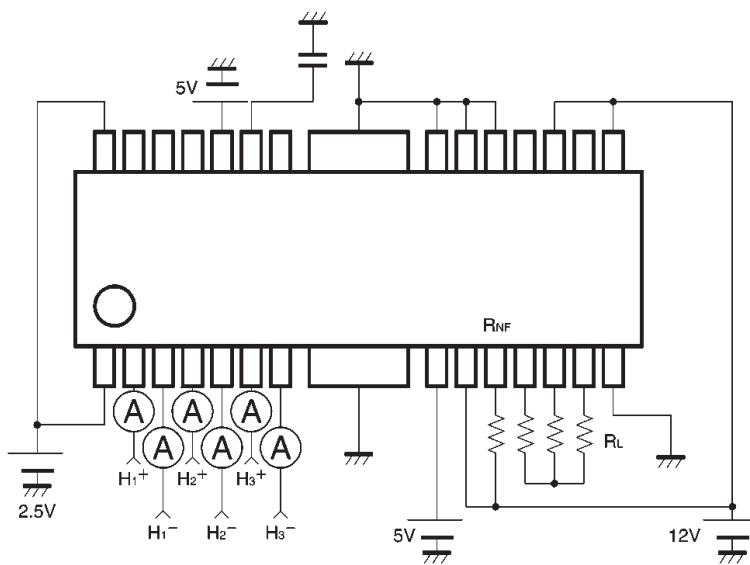

Fig.6

$I_{HA}$  : With  $H_n^+ = 4.0V$ ,  $H_n^- = 2.5V$ ,  
 the current that flows into  $H_n^+$   
 With  $H_n^+ = 2.5V$ ,  $H_n^- = 4.0V$ ,  
 the current that flows into  $H_n^-$   
 ( $n = 1, 2, 3$ )

$V_{HAR}$  : Hall input voltage range for which  
 the output pin is as per the Input /  
 output table.  
 $V_{INH}$  : Hall input level for which the output  
 pin is as per the Input / output table.  
 $|H_n^+ - H_n^-|$        $H_{in}^- = 2.5V$

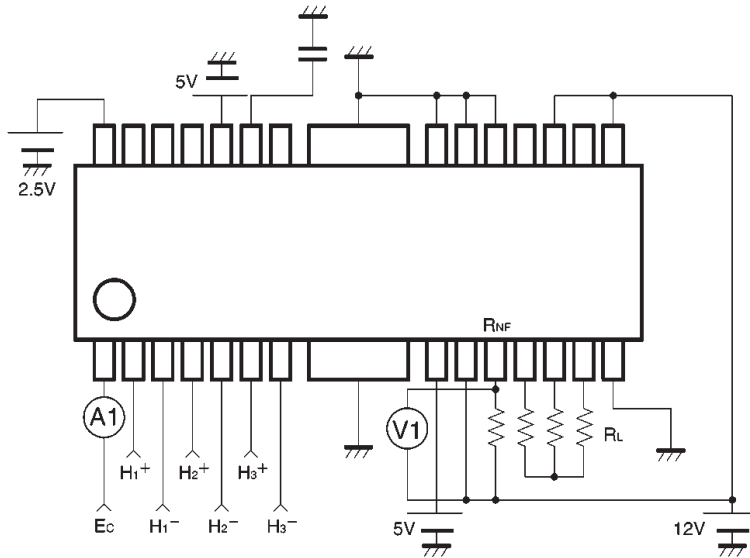

Fig.7

- $E_C, E_{CR}$  : Torque command operation voltage range
- $E_{COF\pm}$  : Vary  $E_C$  until  $E_{CR} = 2.5V$ , then Vary  $E_C$  voltmeter  $V1 < 3mV$ . This  $E_C$  voltage range (see operation notes (2)).
- $E_{CIN}$  : Ammeter value when  $E_C = 2V$  and  $E_{CR} = 2.5V$
- $G_{EC}$  : If the  $V1$  value is  $V2$  when  $E_C = 1.5V$ , and the  $V1$  value is  $V3$  when  $E_C = 2.0V$   
 $G_{EC} = \{(V2 - V3) / (2.0 - 1.5)\} / R_{NF}$  ( $R_{NF} = 0.5\Omega$ )

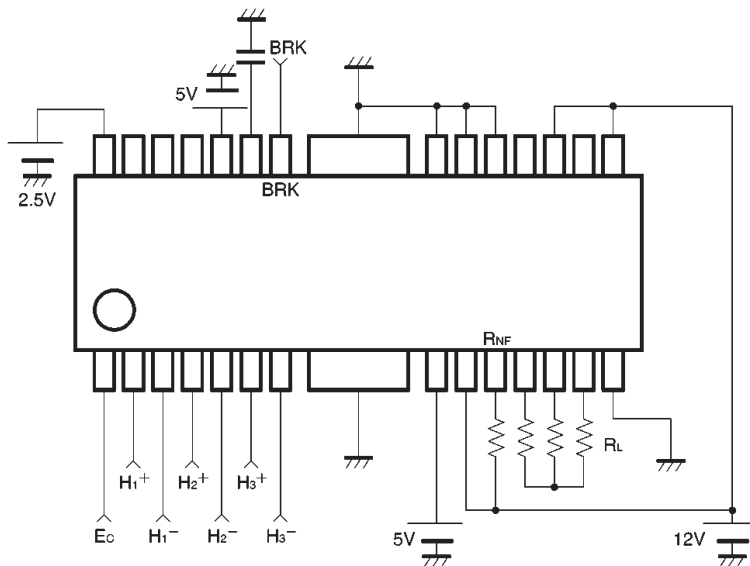

Fig.8

- $V_{SBON}$  : BRK pin voltage range when all output pins are low.
- $V_{SBOFF}$  : BRK pin voltage range when all output pins are as per the Input / output table.



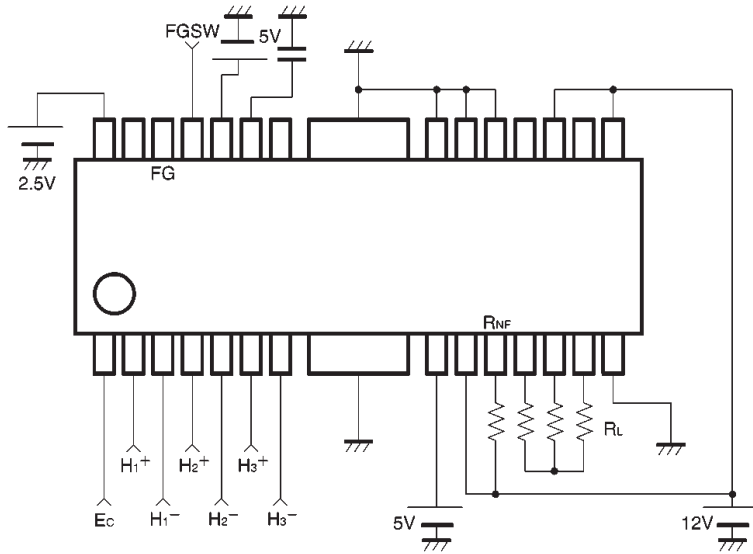

Fig.9

$V_{SWL}$  : FGSW pin voltage range when the hall input and FG output are as per the table below.

H <sub>1</sub> <sup>+</sup>	H <sub>2</sub> <sup>+</sup>	H <sub>3</sub> <sup>+</sup>	FG
L	H	H	L
H	L	L	H

H=2.6V, L=2.4V

Hn<sup>-</sup>=2.5V

$V_{SWH}$  : FGSW pin voltage range when the hall input and FG output are as per the table below.

H <sub>1</sub> <sup>+</sup>	H <sub>2</sub> <sup>+</sup>	H <sub>3</sub> <sup>+</sup>	FG
L	L	H	L
H	L	H	H
H	L	L	L
H	H	L	H
L	H	L	L
L	H	H	H

H=2.6V, L=2.4V

Hn<sup>-</sup>=2.5V

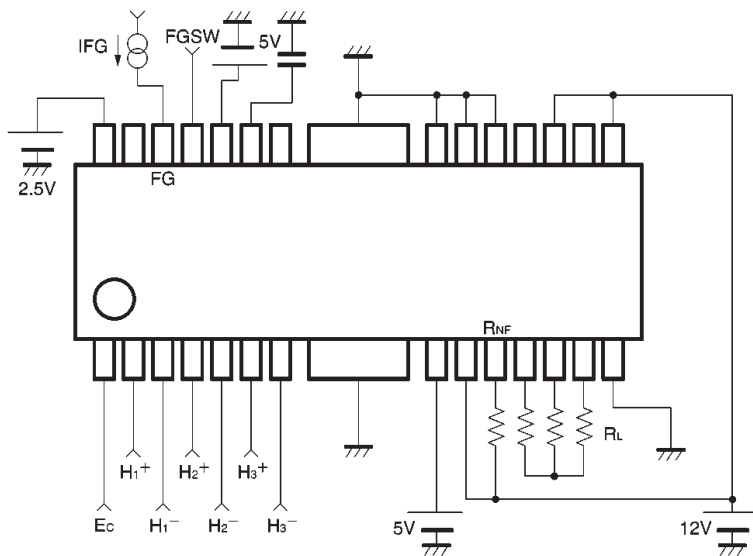

Fig.10

$V_{FGH}$  : Voltmeter V1 value  
(Input / output table, condition 2)

IFG = -10μA

FGSW = 0V

$V_{FGL}$  : Voltmeter V1 value  
(Input / output table, condition 1)

IFG = 3mA

FGSW = 0V

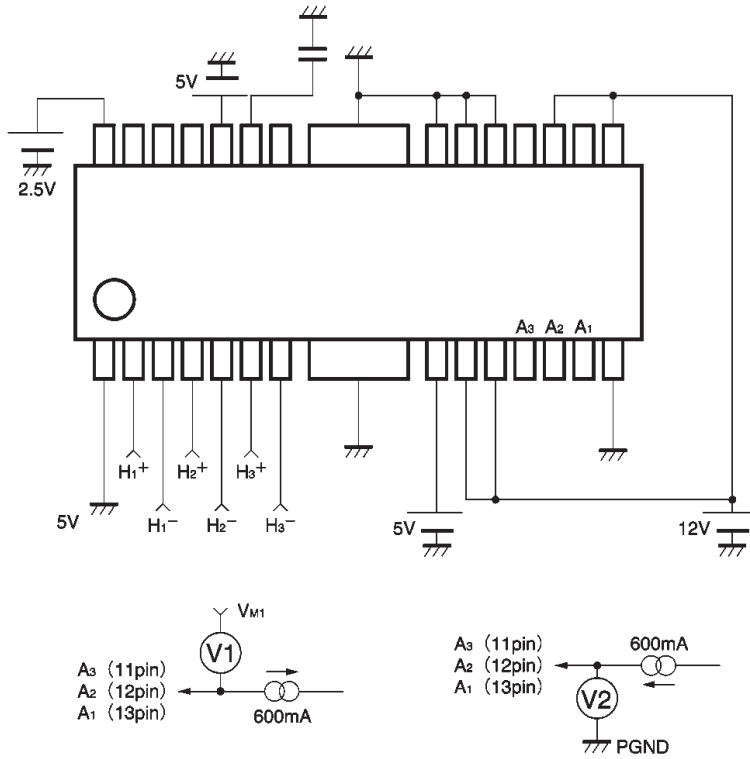

Fig.11

$V_{OH}$  : With the output measurement pin made high level according to the input conditions, the V1 value when 600mA flows from that pin.  
 $V_{OL}$  : With the output measurement pin made low level according to the input conditions, the V2 value when 600mA flows from that pin.

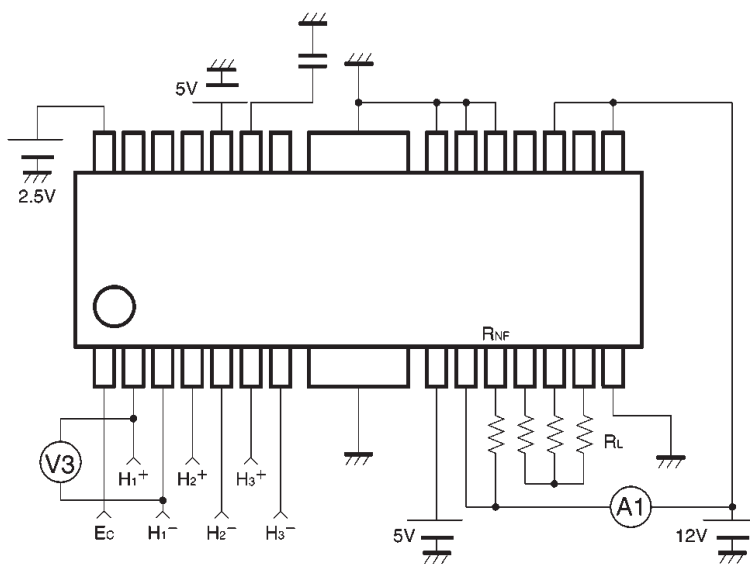

Fig.12

$V_{HYS}$  : The voltage difference V3 between  $H1^+$  and  $H1^-$  that switch the FG pin.  
 $E_c = 2.5V$   
 $FGSW = 0V$   
 $I_{VMD}$  : Ammeter A1 value  
 Output open (input conditions 1 to 6)  
 $E_c = 0V$

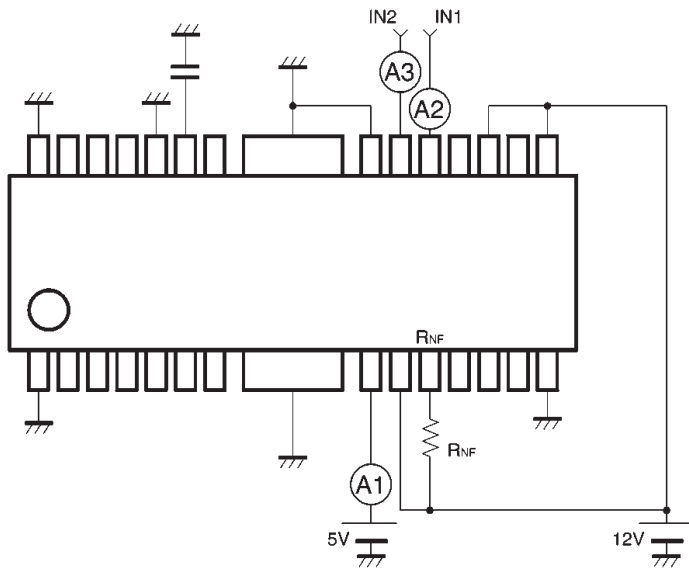

Fig.13

- I<sub>CC4</sub> : Ammeter A1 value  
IN1 = 5V, IN2 = 0V
- I<sub>CC5</sub> : Ammeter A1 value  
IN1 = 5V, IN2 = 5V
- V<sub>IH</sub> : IN1 range for which OUT1 = High,  
OUT2 = Low (IN2 = Low)  
  
IN2 range for which OUT1 = Low,  
OUT2 = High (IN1 = Low)
- V<sub>IL</sub> : IN1 range for which OUT1 = Low,  
OUT2 = High (IN2 = High)  
IN2 range for which OUT1 = High,  
OUT2 = Low (IN1 = High)
- I<sub>IH</sub> : Ammeter A2 value when IN1 = 2V  
Ammeter A3 value when IN2 = 2V

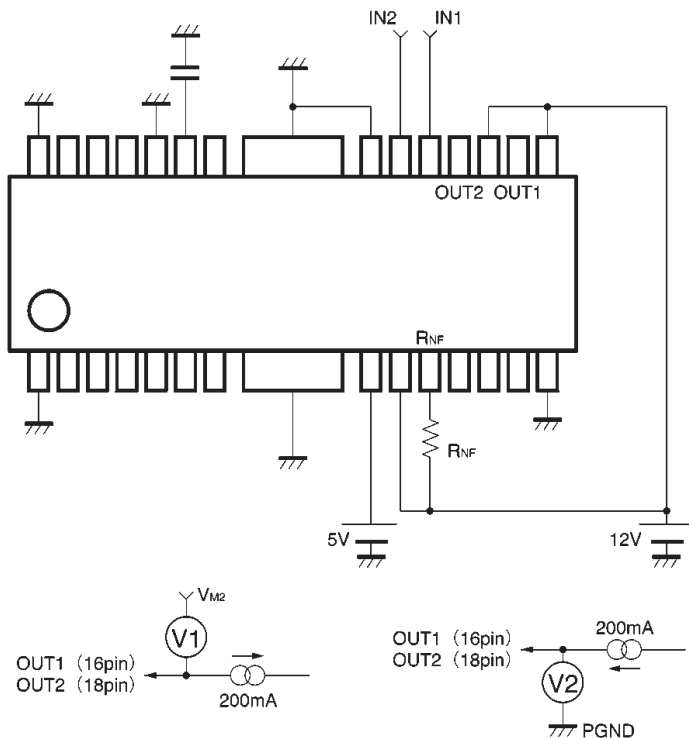
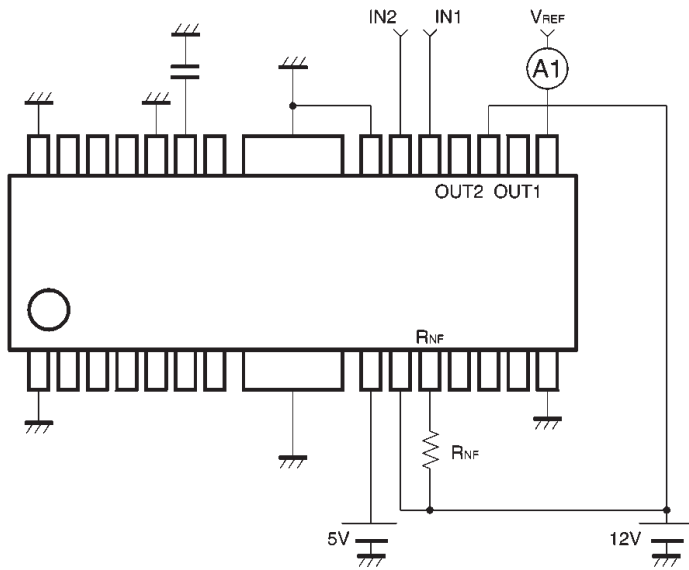

Fig.14

- V<sub>CE</sub> : Sum of V1 (the value when 200mA is  
flowing from the output high level pin)  
and V2 (the value when 200mA is  
flowing to the output low level pin).



$I_{REF}$  : Ammeter A1 value  
 $I_o = 100\text{mA}$   
 $V_{REF} = 9\text{V}$

$V_{REF}$  :  $V_{REF}$  pin voltage range for which the output voltage can be controlled

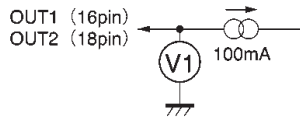

Fig.15

● Operation notes

(1) Torque command

The  $R_{NF}$  pin voltage with respect to the torque command input ( $E_C$ ) is as follows.

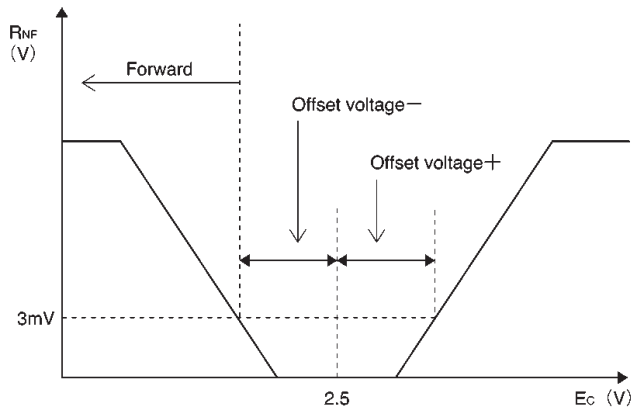

Fig.16

The I / O gain  $G_{EC}$  from the  $E_C$  pin to the  $R_{NF}$  (output current) is determined by the  $R_{NF}$  detector resistance.

$$G_{EC} = 0.25 / R_{NF} \text{ (A / V)}$$

The torque limit current  $I_{TL}$  is given by

$$I_{TL} = 0.35 / R_{NF} \text{ (A)}$$

	Rotation direction
$E_C < E_{CR}$	Forward
$E_C > E_{CR}$	Reverse*

\* Stops after reverse is detected.

(2) Power save

The power save pin logic is as follows.

Mode	PS pin
Power save mode	Outflow or pulled down to GND
FG, hall bias operation mode	Open
Spindle operation mode	Inflow or pulled up to $V_{CC}$

(3) Reverse rotation detector

The construction of the reverse rotation detector circuit is shown in Fig. 17.

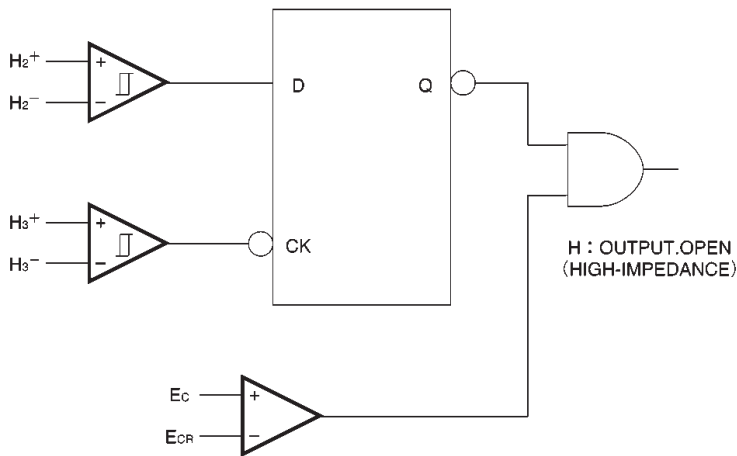

Fig.17

1) Forward ( $E_C < E_{CR}$ )

The phase relationship between the hall input signals  $H_2^+$  and  $H_3^+$  is as shown in Fig.18, and the reverse rotation detector circuit does not operate.

2) Reverse ( $E_C > E_{CR}$ )

The phase relationship between  $H_2^+$  and  $H_3^+$  is opposite to that for forward rotation, and the reverse rotation detector circuit operates to switch the output off and leave it in the open state.

Motor operation during reverse detection

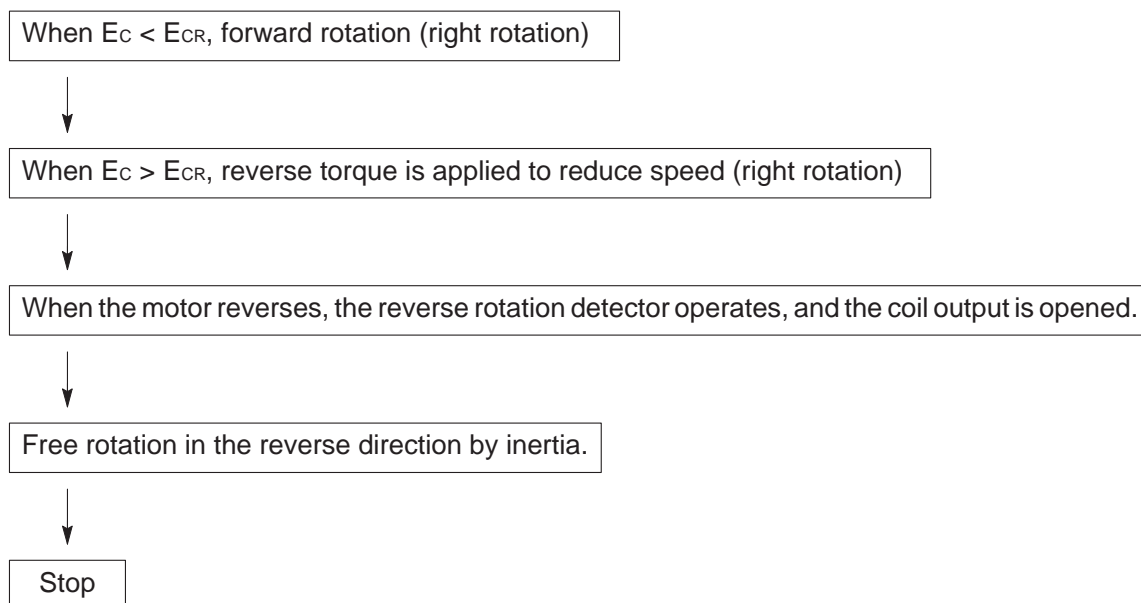

(4) Input / output timing chart (forward rotation)

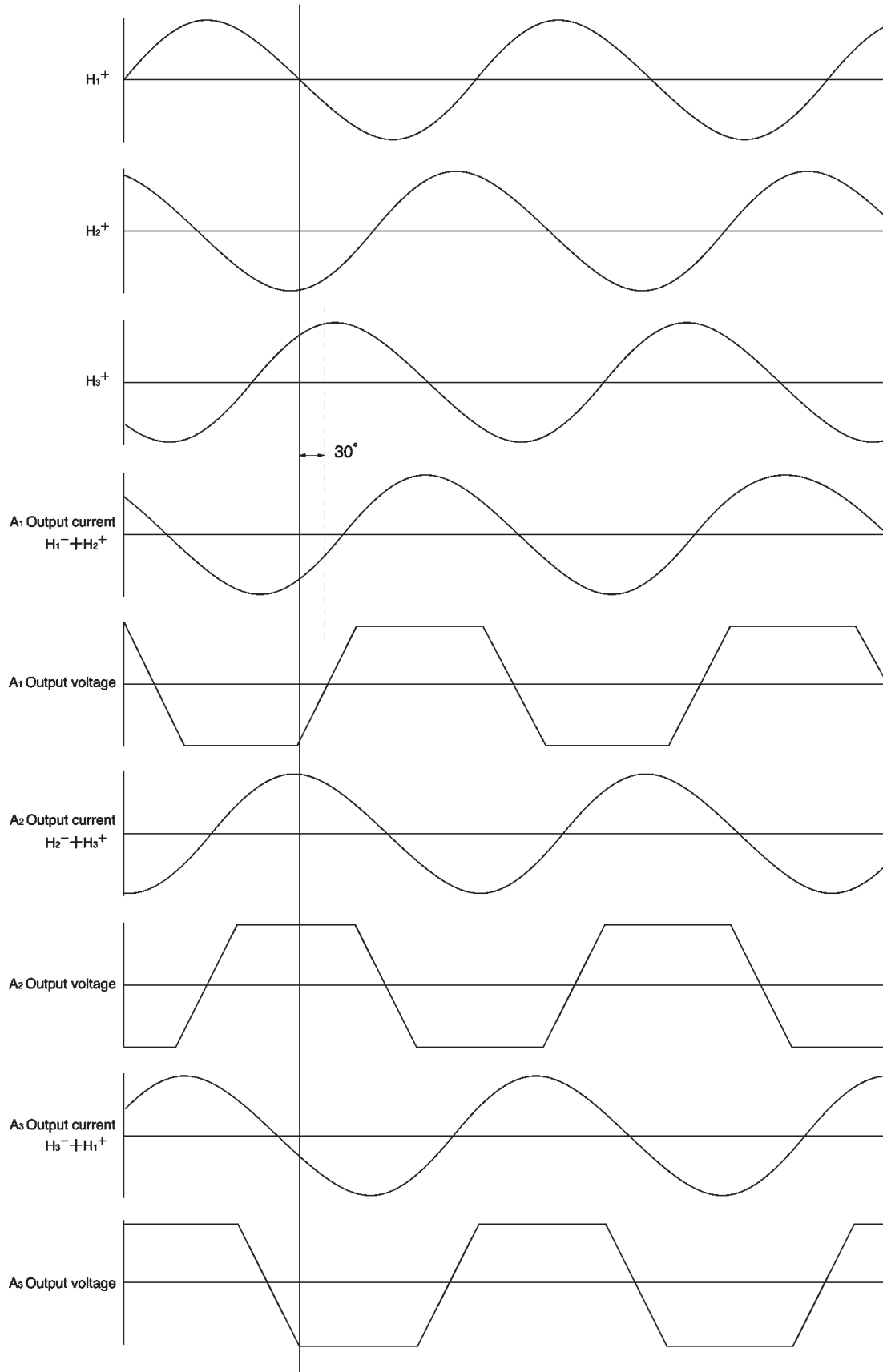

Fig.18

(5) Short brake

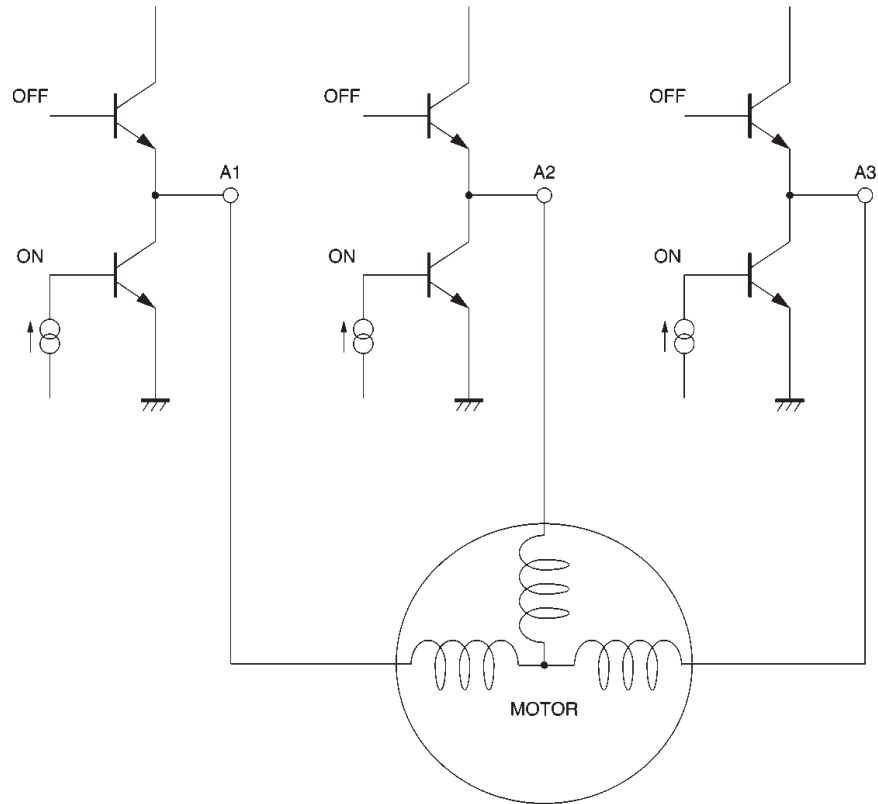

Fig.19

When the BRK pin goes to high level, the upper-side output transistors (three phase) go off, and the lower-side output transistors (three phase) go on.

(6) Hall input

The hall pins can be connected in series or parallel.

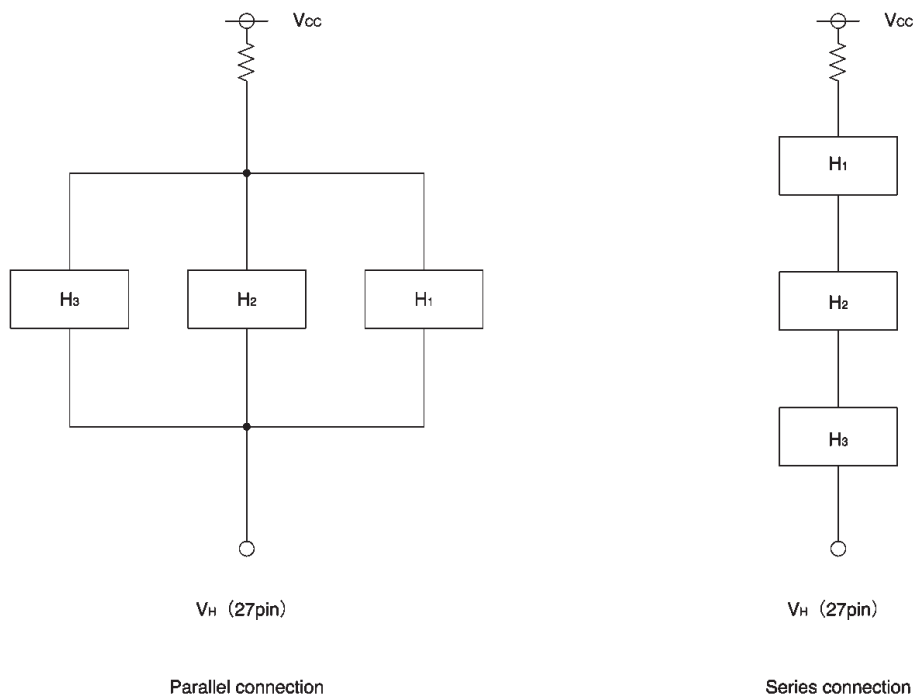

Fig.20

(7) FG output switch

The relationship between the FG output switch pin and the FG output is as follows.

	FG output mode
FGSW="H"	Three-phase composite output
FGSW="L"	Single-phase output

(8) About the input pin applied voltage

Do not apply voltage to any of the other pins when the V<sub>CC</sub> voltage is not being supplied to the IC. In addition, when V<sub>CC</sub> is being applied, do not apply a voltage more than V<sub>CC</sub> to any of the other pins.

(9) Input pins

The loading input pin has a negative temperature characteristic, so when using it, give due consideration to the temperature characteristics.

(10) V<sub>REF</sub> pin (output high level voltage setting)

The loading block output high level voltage can be set using the V<sub>REF</sub> pin voltage.

The output high level voltage V<sub>OH</sub> is given by the following formula.

$$V_{OH} = V_{REF} + I_{REF} \times R1 + V_{BE} (Q1) - V_{BE} (Q3)$$

The V<sub>REF</sub> voltage that brings about the above formula is up to V<sub>M2</sub> - V<sub>CE</sub> (Q2) - V<sub>BE</sub> (Q3).

Do not apply a voltage of more than V<sub>M2</sub> to the V<sub>REF</sub> pin. Short the V<sub>REF</sub> pin to V<sub>M2</sub> if you will not use it.

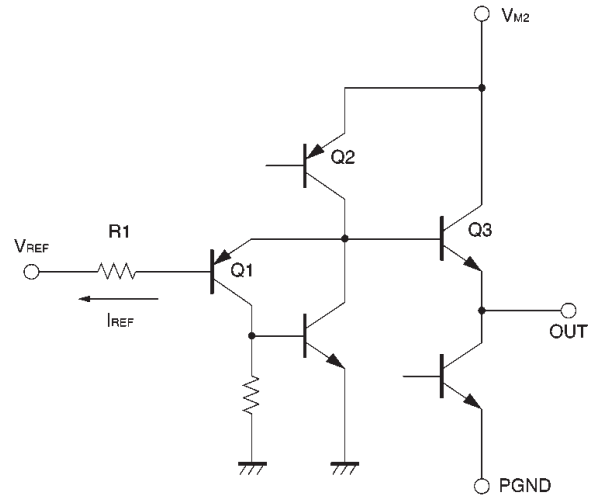

Fig.21

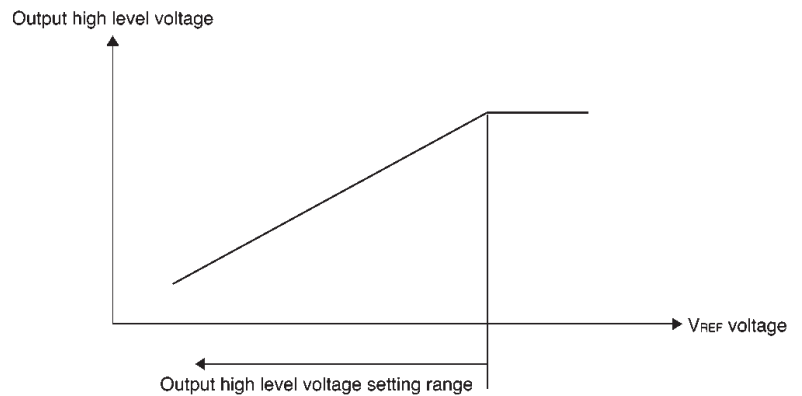

Fig.22



(11) Spindle and loading operation conditions

When IN1 or IN2 are high level, the spindle is off regardless of the PS pin input.

PS	Spindle operation mode	IN1	IN2	OUT1	OUT2
*	Refer to item (2) of the operation notes	L	L	OPEN	OPEN
**	OPEN	H	L	H	L
**	OPEN	L	H	L	H
**	OPEN	H	H	L	L

\* : Refer to item of (2) the operation notes.

\*\* : All input patterns.

(12) Driver section ground (GND)

PGND (pin 14) is the driver section GND, and is not connected to the signal section GND. This is the motor current path, so take care with the PCB track width and arrangement on the PC board.

(13) Thermal shutdown (TSD)

When the junction temperature reaches 175°C (Typ.), the motor output is opened. There is approximately 15°C (Typ.) of temperature hysteresis.

●Electrical characteristics curves

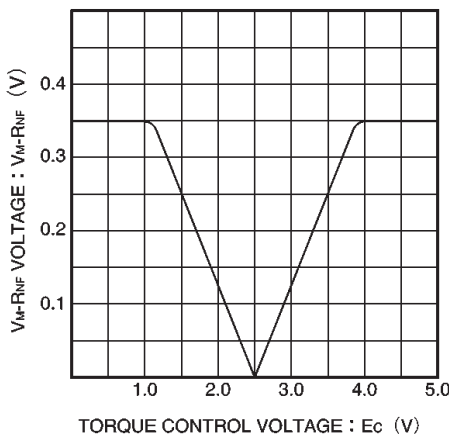

Fig.23 Torque gain / limit characteristics

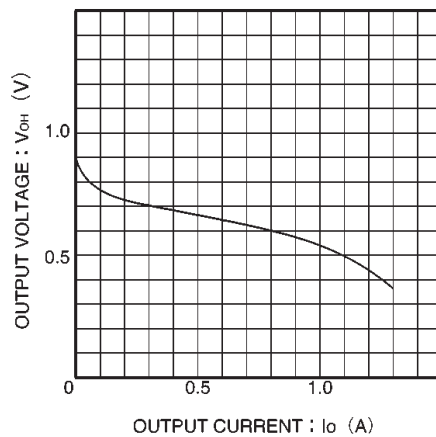

Fig.24 Spindle upper-side output saturation characteristics

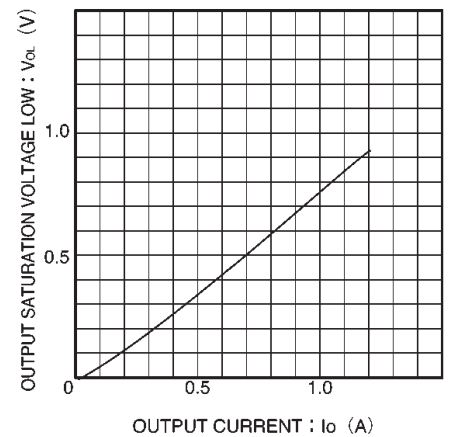

Fig.25 Spindle lower-side output saturation characteristics

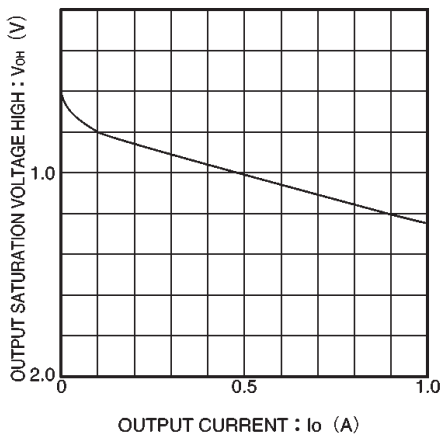

Fig.26 Loading section upper-side output saturation characteristics

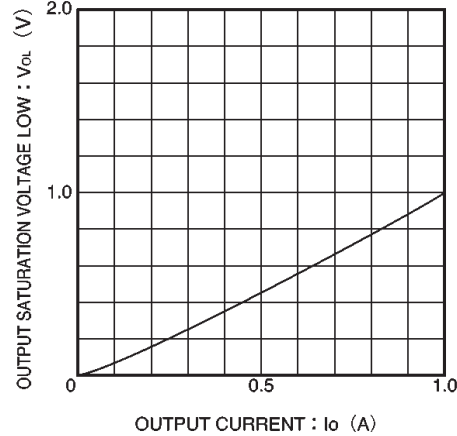

Fig.27 Loading section lower-side output saturation characteristics

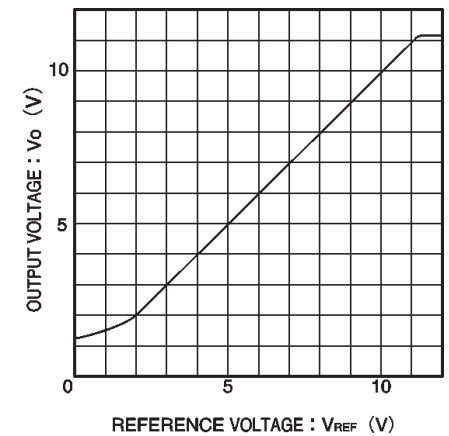

Fig.28  $V_{REF}$   $V_{OUT}$  characteristics

● External dimensions (Units: mm)

