

General Description

- DDC144TU is best suited for logic switching applications using control circuits like micro-controllers, comparators, etc. It features two discrete NPN transistors which can support maximum continuous current of 100 mA. NPN transistors can be used as a control and also these can be biased using higher supply voltages due to the built in current limiting base resistor of 47 K Ohm. The component devices can be used as a part of a circuit or as a stand alone discrete device.



Fig. 1: SOT-363

Features

- Built in Base Resistors
- Epitaxial Planar Die Construction
- Lead Free By Design/RoHS Compliant (Note 1)
- "Green" Device (Note 2)

Mechanical Data

- Case: SOT-363
- Case Material: Molded Plastic. "Green Molding" Compound. UL Flammability Classification Rating 94V-0
- Moisture Sensitivity: Level 1 per J-STD-020C
- Terminal Connections: See Fig. 2
- Terminals: Finish - Matte Tin annealed over Alloy 42 leadframe. Solderable per MIL-STD-202, Method 208
- Marking & Type Code Information: See Page 5
- Ordering Information: See Page 5
- Weight: 0.015 grams (approximate)

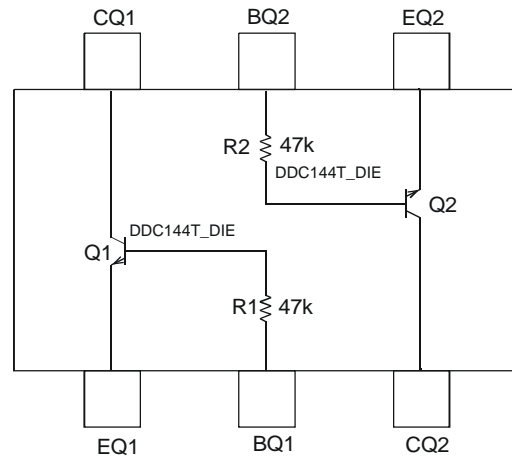

Fig. 2: Schematic and Pin Configuration

Sub-Component P/N	Reference	Device Type	R1 (NOM)	R2 (NOM)	Figure
DDTC144T_DIE	Q1	NPN	47KΩ	—	2
DDTC144T_DIE	Q2	NPN	—	47KΩ	2

Maximum Ratings: Total Device @T_A = 25°C unless otherwise specified

Characteristic	Symbol	Value	Unit
Power Dissipation	P _d	200	mW
Power Deration above 25°C	P _{der}	1.6	mW / °C
Output Current	I _{out}	100	mA

Thermal Characteristics

Characteristic	Symbol	Value	Unit
Junction Operation and Storage Temperature Range	T _J , T _{STG}	-55 to +150	°C
Thermal Resistance, junction to ambient (packaged device) (Ref: equivalent to only one heated junction) @ T _A = 25°C	R _{θJA}	625	°C/W

- Notes:
1. No purposefully added lead.
 2. Diodes Inc.'s "Green" policy can be found on our website at http://www.diodes.com/products/lead_free/index.php.
 3. Device mounted on FR-4 PCB, 1" x 0.85" x 0.062"; pad layout as shown on Page 5 or see Diodes Inc. suggested pad layout document AP02001, which can be found on our website at <http://www.diodes.com/datasheets/ap02001.pdf>.

Maximum Ratings:
Sub-Component Device: Discrete NPN Transistor (Q1, Q2) @ $T_A = 25^\circ\text{C}$ unless otherwise specified

Characteristic	Symbol	Value	Unit
Collector-Base Voltage	V_{CB0}	50	V
Collector-Emitter Voltage	V_{CEO}	50	V
Emitter-Base Voltage	V_{EBO}	6	V
Collector Current (dc)	$I_{C(max)}$	50	mA

Electrical Characteristics @ $T_A = 25^\circ\text{C}$ unless otherwise specified

Characteristic	Symbol	Min	Typ	Max	Unit	Test Condition
Off Characteristics						
Collector-Base Cut Off Current	I_{CBO}	—	—	100	nA	$V_{CB} = 50\text{V}, I_E = 0$
Collector-Emitter Cut Off Current, $I_{O(OFF)}$	I_{CEO}	—	—	500	nA	$V_{CE} = 50\text{V}, I_B = 0$
Emitter-Base Cut Off Current	I_{EBO}	—	—	500	nA	$V_{EB} = 5\text{V}, I_C = 0$
Collector-Base Breakdown Voltage	$V_{(BR)CBO}$	50	—	—	V	$I_C = 50\mu\text{A}, I_E = 0$
Collector-Emitter Breakdown Voltage	$V_{(BR)CEO}$	50	—	—	V	$I_C = 1\text{mA}, I_B = 0$
Emitter-Base Breakdown Voltage	$V_{(BR)EBO}$	6	—	—	V	$I_E = 50\mu\text{A}, I_C = 0$
Output Voltage (Transistor is off)	V_{OH}	4.6	4.45	—	V	$V_{CC} = 5\text{V}, V_B = 0.05\text{V}, R_L = 1\text{K}\Omega$
Input Voltage (load is off)	$V_{I(OFF)}$	—	0.6	0.4	—	$V_{CE} = 5\text{V}, I_C = 100\mu\text{A}$
Output Current (leakage same as I_{CEO})	$I_{O(OFF)}$	—	—	850	nA	$V_{CC} = 50\text{V}, V_I = 0\text{V}$
On Characteristics*						
Collector-Emitter Saturation Voltage	$V_{CE(SAT)}$	—	0.03	0.1	V	$I_C = 2.5\text{mA}, I_B = 0.25\text{mA}$
		—	0.075	0.1	V	$I_C = 10\text{mA}, I_B = 0.5\text{mA}$
		—	0.05	0.1	V	$I_C = 10\text{mA}, I_B = 1\text{mA}$
		—	0.2	0.3	V	$I_C = 50\text{mA}, I_B = 5\text{mA}$
DC Current Gain	h_{FE}	150	400	—	—	$V_{CE} = 5\text{V}, I_C = 1\text{mA}$
		150	400	—	—	$V_{CE} = 5\text{V}, I_C = 10\text{mA}$
		150	350	—	—	$V_{CE} = 5\text{V}, I_C = 25\text{mA}$
		150	300	—	—	$V_{CE} = 5\text{V}, I_C = 50\text{mA}$
		50	110	—	—	$V_{CE} = 5\text{V}, I_C = 100\text{mA}$
Output Voltage (equivalent to $V_{CE(SAT)}$ or $V_{O(on)}$)	V_{OL}	—	0.2	0.25	Vdc	$V_{CC} = 5\text{V}, V_B = 2.5\text{V}, R_L = 10\text{K}\Omega$
Input Voltage	$V_{I(ON)}$	1.5	0.95	—	Vdc	$V_O = 0.3\text{V}, I_C = 2\text{mA}$
Input Current	I_i	—	19.2	28	mA	$V_I = 5\text{V}$
Base-Emitter Turn-on Voltage	$V_{BE(ON)}$	—	—	1.2	V	$V_{CE} = 5\text{V}, I_C = 2\text{mA}$
Base-Emitter Saturation Voltage	$V_{BE(SAT)}$	—	—	1.6	V	$I_C = 200\mu\text{A}, I_B = 20\mu\text{A}$
Input Resistor +/- 30% (Base)	R1	—	47	—	$\text{K}\Omega$	—
Small Signal Characteristics						
Transition Frequency (gain-bandwidth product)	f_T	—	250	—	MHz	$V_{CE} = 10\text{V}, I_E = 5\text{mA}, f = 100\text{MHz}$
Collector Capacitance, (C _{cb0} -Output Capacitance)	C_C	—	—	5	pF	$V_{CB} = 10\text{V}, I_E = 0, f = 1\text{MHz}$

*Pulse Test: Pulse width, $t_p < 300\ \mu\text{s}$, Duty Cycle, $d \leq 0.02$

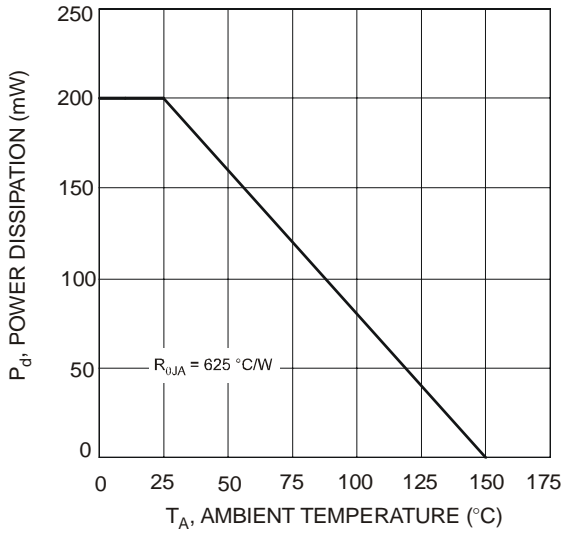

Fig. 3 Maximum Power Derating Curve

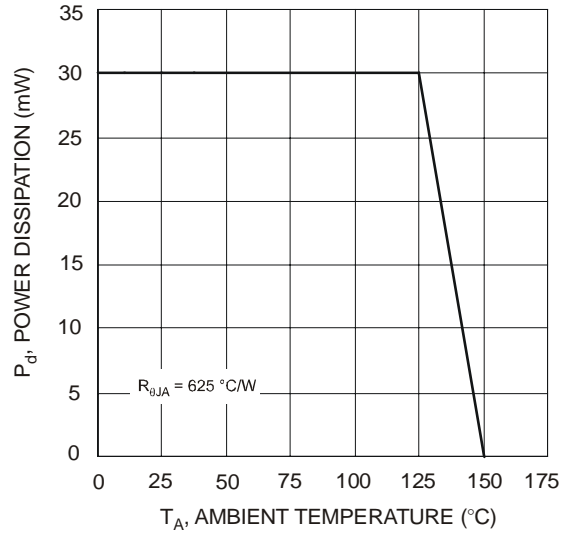

Fig. 4 Power Derating for Nominal Operation

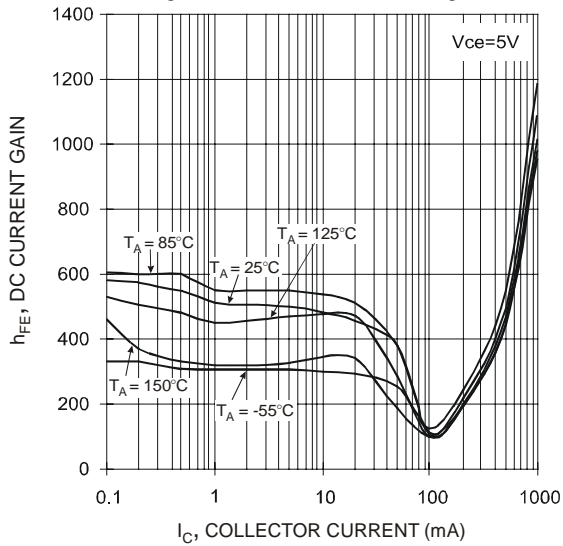

Fig. 5 DC Current Gain

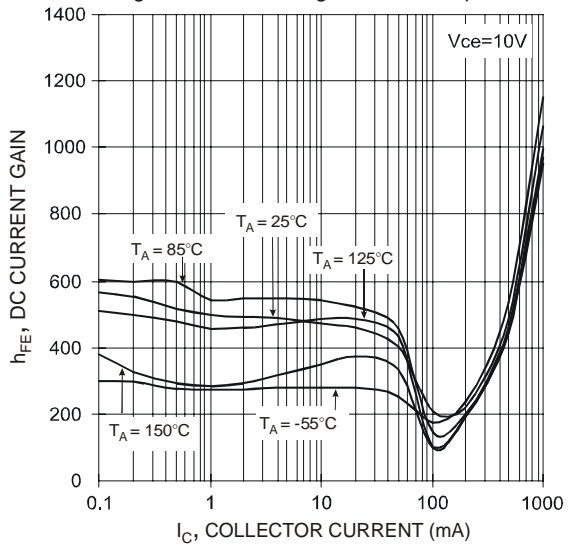

Fig. 6 DC Current Gain

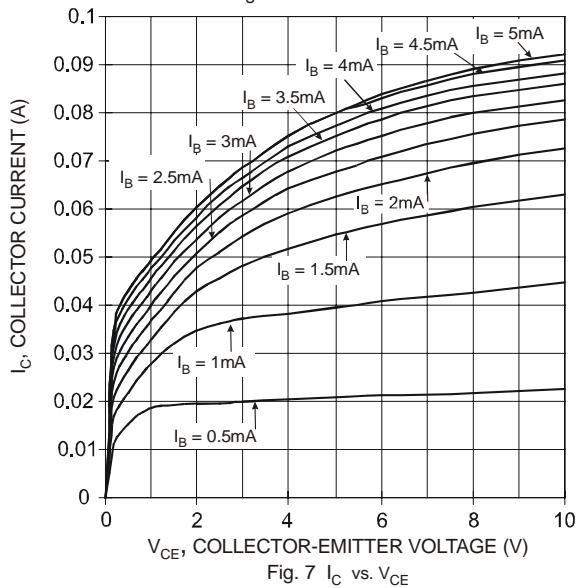

Fig. 7 I_C vs. V_{CE}

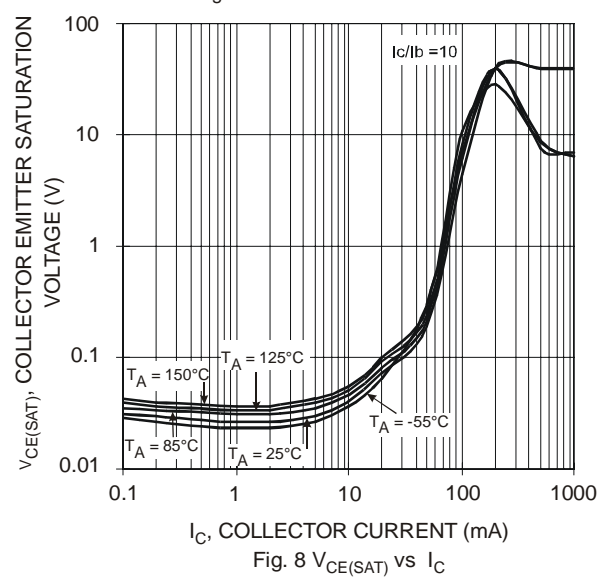

Fig. 8 $V_{CE(SAT)}$ vs I_C

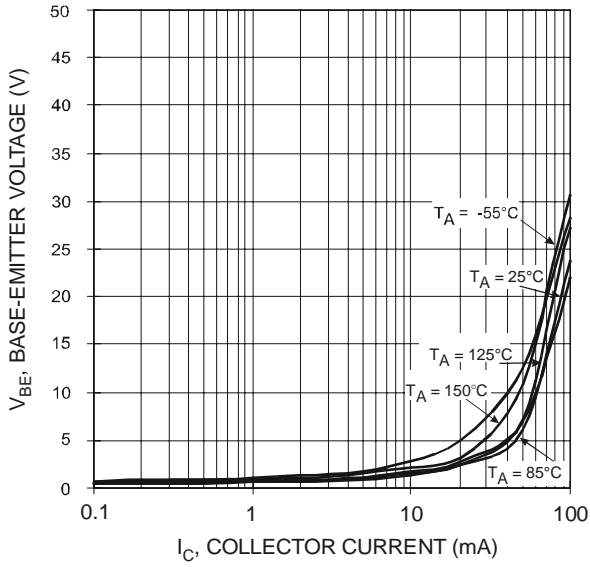

Fig. 9 V_{BE} vs I_C

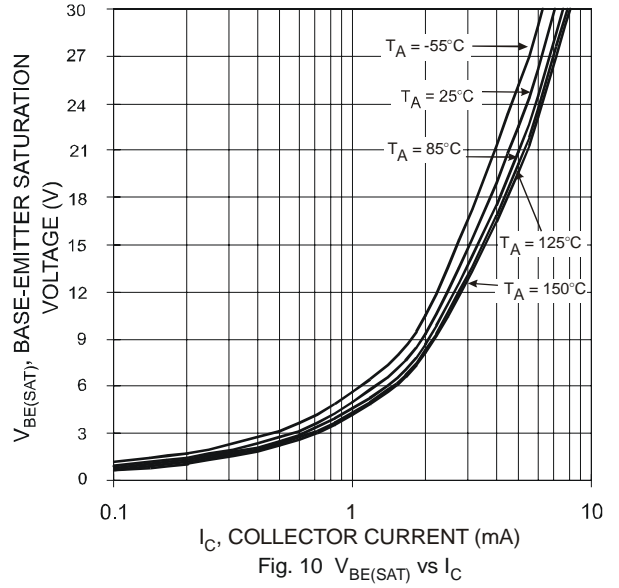

Fig. 10 $V_{BE(SAT)}$ vs I_C

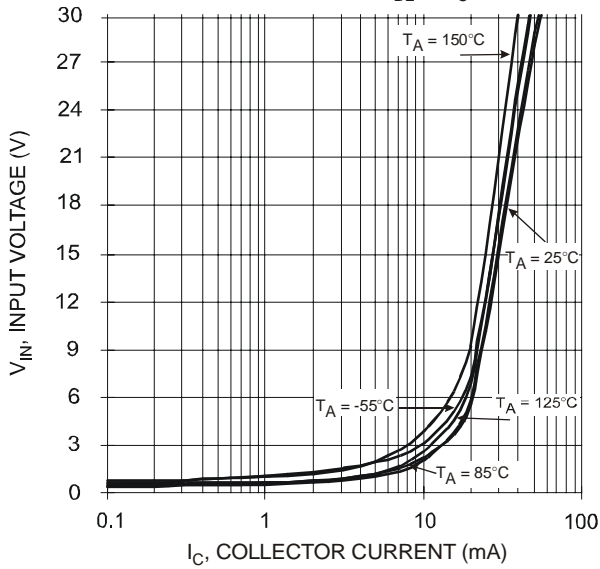

Fig. 11 Input Voltage vs Output Current

Ordering Information (Note 4)

Device	Marking Code	Packaging	Shipping
DDC144TU-7	N21	SOT-363	3000/Tape & Reel

Notes: 4. For Packaging Details, please see below or go to our website at <http://www.diodes.com/datasheets/ap02007.pdf>.

Marking Information

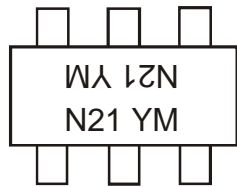

N21 = Product Type Marking Code
 YM = Date Code Marking
 Y = Year e.g., U = 2007
 M = Month e.g., 9 = September

Fig. 12

Date Code Key

Year	2006	2007	2008	2009	2010	2011	2012
Code	T	U	V	W	X	Y	Z

Month	Jan	Feb	Mar	Apr	May	Jun	Jul	Aug	Sep	Oct	Nov	Dec
Code	1	2	3	4	5	6	7	8	9	O	N	D

Mechanical Details

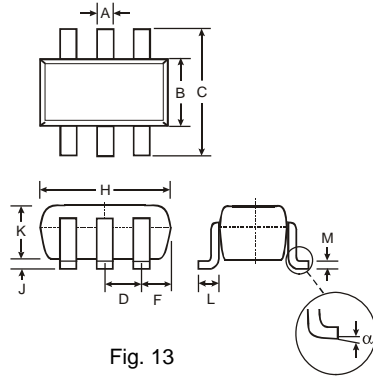

Fig. 13

SOT-363		
Dim	Min	Max
A	0.10	0.30
B	1.15	1.35
C	2.00	2.20
D	0.65 Nominal	
F	0.30	0.40
H	1.80	2.20
J	-	0.10
K	0.90	1.00
L	0.25	0.40
M	0.10	0.25
α	0°	8°

All Dimensions in mm

Suggested Pad Layout: (Based on IPC-SM-782)

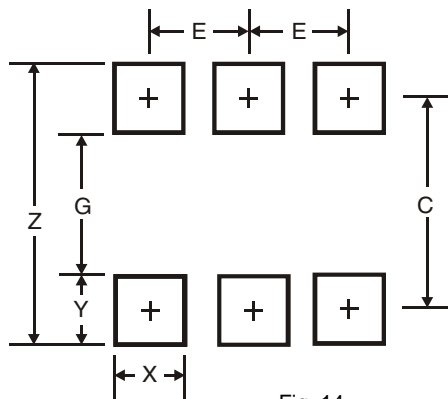

Fig. 14

Figure 14 Dimensions	SOT-363
Z	2.5
G	1.3
X	0.42
Y	0.6
C	1.9
E	0.65

All Dimensions in mm

IMPORTANT NOTICE

Diodes Incorporated and its subsidiaries reserve the right to make modifications, enhancements, improvements, corrections or other changes without further notice to any product herein. Diodes Incorporated does not assume any liability arising out of the application or use of any product described herein; neither does it convey any license under its patent rights, nor the rights of others. The user of products in such applications shall assume all risks of such use and will agree to hold Diodes Incorporated and all the companies whose products are represented on our website, harmless against all damages.

LIFE SUPPORT

Diodes Incorporated products are not authorized for use as critical components in life support devices or systems without the expressed written approval of the President of Diodes Incorporated.