

Triple/Quad Single-Wire Temp Sensor in MSOP-8 Using SMSC BudgetBus[™] Sensor Interface

Datasheet

General Description

The EMC1203 and EMC1204 are temperature sensors that communicate with a host over a single-wire SMSC BudgetBus[™] Sensor Interface. The EMC1203 has an internal temperature sensor and monitors up to two remote diodes. An additional remote diode is added with the EMC1204 for a total of three remote zones, and both devices are in a small MSOP-8 package. When used in combination with an SMSC Super I/O host, such as a keyboard controller, a complete thermal management system is created. A power down mode preserves battery life in portable applications. The internal 11-bit sigma delta temperature-to-digital converter provides superb linearity, high accuracy and excellent noise immunity.

PART NUMBER	INTERNAL TEMPERATURE MONITOR	REMOTE TEMPERATURE MONITOR
EMC1203	1	2
EMC1204	1	3

Features

- Single-wire SMSC BudgetBus[™] Sensor Interface
- Low Power, 3.0V to 3.6V Supply
 - < 50uA at 1 conversion per second
 - < 2.5uA in Standby
- External Temperature Sensor
 - Range -63.875° C to +191.875° C
 - 0.125° C resolution
 - ±1° C Accuracy 60° C to 100° C
 - Diode Fault Reporting
- Self Contained Internal Temperature Sensor
 - Range 0° C to +85° C
 - 0.125° C resolution
 - ±3° C Accuracy 0° C to 85° C
- MSOP-8 3x3mm packages; green, lead-free packages also available

Applications

- Desktop Computers
- Notebook Computers
- Server Applications

Simplified Block Diagram

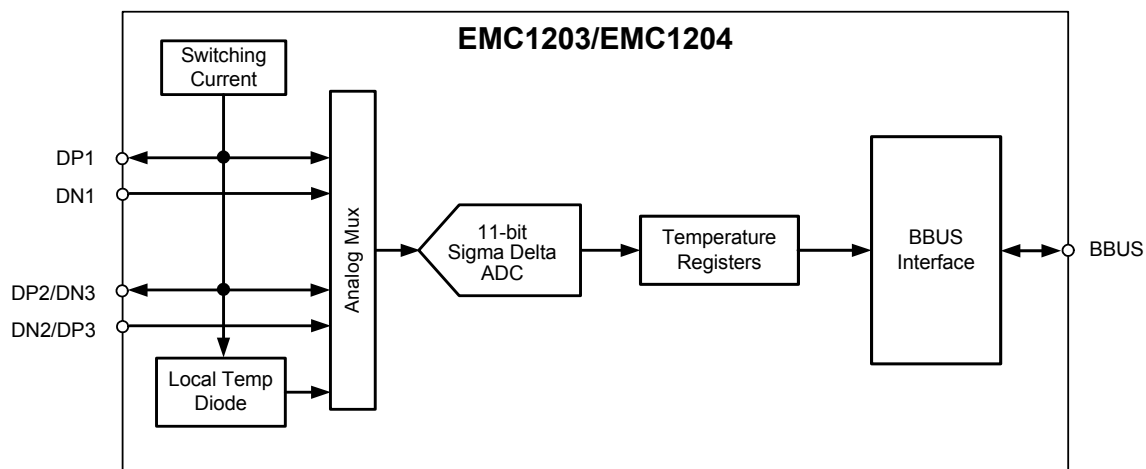

ORDER NUMBER(S):**EMC1203-ACZL-TR IN 8 PIN MSOP PACKAGE (GREEN, LEAD-FREE)****EMC1204-ACZL-TR IN 8 PIN MSOP PACKAGE (GREEN, LEAD-FREE)**

Reel size is 4,000 pieces.

Evaluation Board available upon request. (EVB-KBC1100)



80 ARKAY DRIVE, HAUPPAUGE, NY 11788 (631) 435-6000, FAX (631) 273-3123

Copyright © 2006 SMSC or its subsidiaries. All rights reserved.

Circuit diagrams and other information relating to SMSC products are included as a means of illustrating typical applications. Consequently, complete information sufficient for construction purposes is not necessarily given. Although the information has been checked and is believed to be accurate, no responsibility is assumed for inaccuracies. SMSC reserves the right to make changes to specifications and product descriptions at any time without notice. Contact your local SMSC sales office to obtain the latest specifications before placing your product order. The provision of this information does not convey to the purchaser of the described semiconductor devices any licenses under any patent rights or other intellectual property rights of SMSC or others. All sales are expressly conditional on your agreement to the terms and conditions of the most recently dated version of SMSC's standard Terms of Sale Agreement dated before the date of your order (the "Terms of Sale Agreement"). The product may contain design defects or errors known as anomalies which may cause the product's functions to deviate from published specifications. Anomaly sheets are available upon request. SMSC products are not designed, intended, authorized or warranted for use in any life support or other application where product failure could cause or contribute to personal injury or severe property damage. Any and all such uses without prior written approval of an Officer of SMSC and further testing and/or modification will be fully at the risk of the customer. Copies of this document or other SMSC literature, as well as the Terms of Sale Agreement, may be obtained by visiting SMSC's website at <http://www.smisc.com>. SMSC is a registered trademark of Standard Microsystems Corporation ("SMSC"). Product names and company names are the trademarks of their respective holders.

SMSC DISCLAIMS AND EXCLUDES ANY AND ALL WARRANTIES, INCLUDING WITHOUT LIMITATION ANY AND ALL IMPLIED WARRANTIES OF MERCHANTABILITY, FITNESS FOR A PARTICULAR PURPOSE, TITLE, AND AGAINST INFRINGEMENT AND THE LIKE, AND ANY AND ALL WARRANTIES ARISING FROM ANY COURSE OF DEALING OR USAGE OF TRADE. IN NO EVENT SHALL SMSC BE LIABLE FOR ANY DIRECT, INCIDENTAL, INDIRECT, SPECIAL, PUNITIVE, OR CONSEQUENTIAL DAMAGES; OR FOR LOST DATA, PROFITS, SAVINGS OR REVENUES OF ANY KIND; REGARDLESS OF THE FORM OF ACTION, WHETHER BASED ON CONTRACT; TORT; NEGLIGENCE OF SMSC OR OTHERS; STRICT LIABILITY; BREACH OF WARRANTY; OR OTHERWISE; WHETHER OR NOT ANY REMEDY OF BUYER IS HELD TO HAVE FAILED OF ITS ESSENTIAL PURPOSE, AND WHETHER OR NOT SMSC HAS BEEN ADVISED OF THE POSSIBILITY OF SUCH DAMAGES.

Chapter 1 Pin Configuration

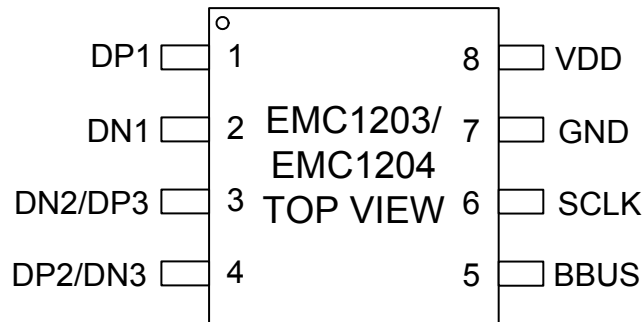

Figure 1.1 EMC1203 and EMC1204 Pin Configuration

1.1 Pin Description

Table 1.1 EMC1203 and EMC1204 Pin Description

PIN	PIN NO.	DESCRIPTION
DP1	1	Positive Analog Connection to External Temperature Diode 1
DN1	2	Negative Analog Connection to External Temperature Diode 1
DN2/DP3	3	Negative Analog Connection to External Temperature Diode 2 Positive Analog Connection to External Temperature Diode 3, EMC1204 only
DP2/DN3	4	Positive Analog Connection to External Temperature Diode 2 Negative Analog Connection to External Temperature Diode 3, EMC1204 only
BBUS	5	Serial Bus Interface to BBUS Host
SCLK	6	Normally GND, this pin may be configured to source a synchronous clock.
GND	7	Ground
VDD	8	Supply Voltage V_{DD}

1.2 Absolute Maximum Ratings

Table 1.2 EMC1203 and EMC1204 Maximum Ratings

DESCRIPTION	RATING	UNIT
Supply Voltage V_{DD}	-0.3 to 5.0	V
Voltage on any other pin	-0.3 to $V_{DD} + 0.3$	V
Operating Temperature Range	0 to 85	°C
Storage Temperature Range	-55 to 150	°C
Lead Temperature Range	Refer to JEDEC Spec. J-STD-020	
Package Thermal Characteristics for MSOP-8		
Power Dissipation	TBD	
Thermal Resistance(at 0 air flow)	109.6	°C/W
ESD Rating, All Pins Human Body Model	2000	V

Note: Stresses above those listed could cause damage to the device. This is a stress rating only and functional operation of the device at any other condition above those indicated in the operation sections of this specification is not implied. When powering this device from laboratory or system power supplies, it is important that the Absolute Maximum Ratings not be exceeded or device failure can result. Some power supplies exhibit voltage spikes on their outputs when the AC power is switched on or off. In addition, voltage transients on the AC power line may appear on the DC output. If this possibility exists, it is suggested that a clamp circuit be used.

Chapter 2 Electrical Characteristics

Table 2.1 Electrical Characteristics

V _{DD} =3.0V to 3.6V, T _A = 0°C to +85°C, Typical values at T _A = 27°C unless otherwise noted						
PARAMETER	SYMBOL	MIN	TYP	MAX	UNITS	CONDITIONS
DC Power						
Supply Voltage	V _{DD}	3.0	3.3	3.6	V	
Average Operating Current	I _{DD}		600	650	μA	Active mode (continuous)
	I _{PD}		1.8	2.5	μA	Standby mode
Internal Temperature Measurement						
Accuracy			±1	±3	°C	0°C ≤ T _A ≤ 85°C
External Temperature Measurement						
Temperature Accuracy						
Remote Diode 60°C to 100°C				± 1	°C	15°C ≤ T _A ≤ 70°C
Remote Diode 0°C to 125°C				± 3	°C	0°C ≤ T _A ≤ 85°C
Remote Diode 0°C to 125°C				TBD	°C	-40°C ≤ T _A ≤ 125°C
ADC						
Resolution			0.125		°C	
Conversion Time per sensor			20		ms	

Chapter 3 Product Description

The EMC1203 and EMC1204 are temperature sensors with a proprietary single wire SMSC BudgetBus™ Sensor Interface. Temperature information is communicated to a host device via the serial bus. All intelligence regarding the interpretation of temperature resides in the host. [Figure 3.1, "System Overview"](#) shows a typical system overview:

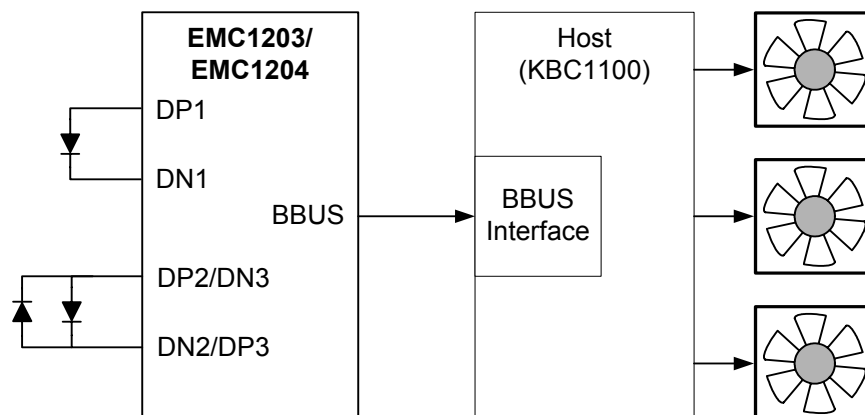

Figure 3.1 System Overview

In cooperation with the host device, thermal management can be performed as shown in [Figure 3.1](#). Thermal management consists of the host acquiring the temperature data from the EMC1203 and EMC1204 controlling the speed of one or more fans. The host has the ability to compare measured temperature levels to preset limits and take the appropriate action when values are found to be out of limit. The EMC1203 and the DP1/DN1 port of the EMC1204 are compatible with CPU substrate diodes.

Two separate temperature zones are monitored using only two pins on the EMC1204. This is accomplished using two anti-parallel diodes as shown on the pins DP2/DN3 and DN2/DP3 in [Figure 3.1](#). This technique maintains high accuracy while minimizing pin count and reducing board routing complexity. The anti-parallel diode architecture performs very well with diode connected transistors. It is not compatible with substrate transistors (sometimes called thermal diodes or on-chip sense junctions).

3.1 Temperature Monitors

Thermal diode temperature measurements are based on the change in forward bias voltage (ΔV_{BE}) of a diode when operated at two different currents:

$$\Delta V_{BE} = V_{BE_HIGH} - V_{BE_LOW} = \frac{\eta k T}{q} \ln \left(\frac{I_{HIGH}}{I_{LOW}} \right)$$

where:

k = Boltzmann's constant

T = absolute temperature in Kelvin

q = electron charge

η = diode ideality factor

The change in ΔV_{BE} voltage is proportional to absolute temperature T .

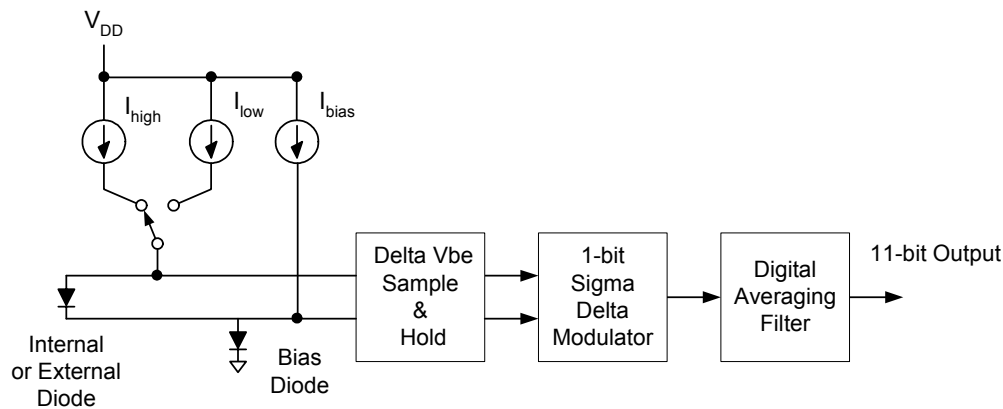

Figure 3.2 Detailed Block Diagram of Temperature Monitor Architecture

Figure 3.2 shows a detailed block diagram of the temperature measurement circuit. As shown, the EMC1203 and EMC1204 incorporates switched capacitor technology that samples the temperature diode voltage at two bias currents and holds the difference voltage. The sample frequency is 100kHz and the current levels I_{high} and I_{low} are 170uA and 10uA respectively.

The output of the switched capacitor sample and hold circuit interfaces to a single bit delta sigma analog to digital converter. This ADC runs at 100kHz sample frequency and its output is digitally filtered and averaged over 2048 samples effectively generating 11 bit accuracy.

The advantages of this architecture over Nyquist rate FLASH or SAR converters are superb linearity and inherent noise immunity. The linearity can be directly attributed to the delta sigma ADC single bit comparator while the noise immunity is achieved by the digital averaging filter. The overall effective bandwidth of the system is $f_s/2048$ which translates to a 50Hz bandwidth at 100kHz sample rate. Conversion time equals about 20ms per temperature monitor.

3.1.1 EMC1203 Temperature Monitoring

The EMC1203, incorporates one internal diode and can monitor two additional temperature zones with two external diodes. An internal analog multiplexer switches between the internal and external diodes. Total conversion time for one internal and two external temperature readings is about 60ms. The external diodes can be either a CPU substrate diode or a discrete diode connected transistor like the 2N3904 or 2N3906. External diode connected transistors examples are shown in Figure 3.3:

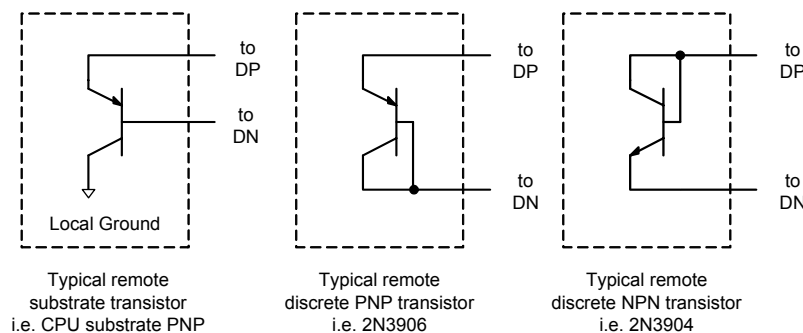

Figure 3.3 EMC1203 External Diode Examples

3.1.2 EMC1204 Temperature Monitoring

The EMC1204, incorporates one internal diode and can monitor three external diodes. Total conversion time for one internal and three external temperature reading is 80ms. An internal multiplexer switches between internal and external diodes. The external thermal diode connected to DP1 and DN1 can

either be a CPU substrate diode or a regular thermal diode-connected transistor. External diodes at DP2/DN3 and DN2/DP3 have to be connected in an anti-parallel fashion. Because of this, one diode will be forward biased while the other is reverse biased and therefore it is recommended to connect only discrete thermal diodes to these pins.

Do not use the anti-parallel interface (DP2/DN3 and DN2/DP3) to connect substrate transistors (sometimes called thermal diodes or on-chip sense junctions). External diode connected transistors examples are shown in [Figure 3.4](#)

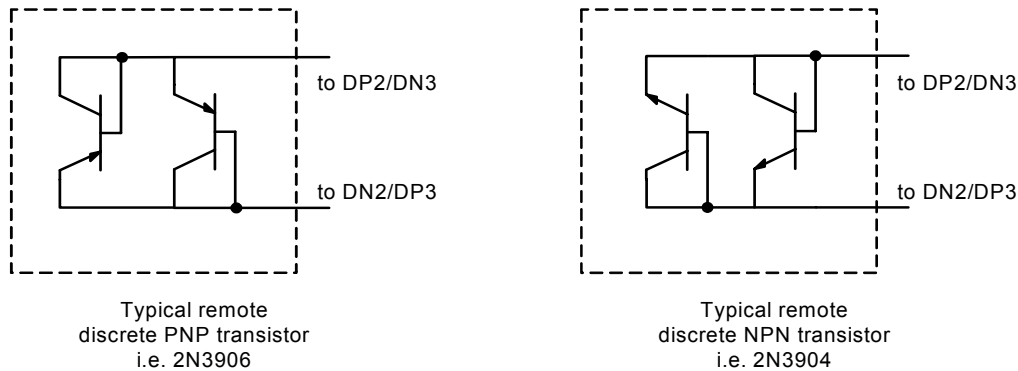

Figure 3.4 EMC1204 External Diode Examples

3.2 SMSC BudgetBus™ Sensor Interface

The EMC1203 and EMC1204 series of temperature monitors communicate with a host controller, such as the KBC1100, through the SMSC BudgetBus™ Sensor Interface. The BBUS is a single wire serial communication protocol between the computer host and its peripheral devices. Please refer to the SMSC BudgetBus™ Sensor Interface Specification for detailed information about the modes of operation.

3.3 Power Modes

The EMC1203 and EMC1204 have two basic modes of operation:

Standby Mode:

The host can initiate standby mode by actively pulling the BBUS low. When the Host places the device in standby mode, the device immediately powers down to draw < 2uA of supply current. It will remain in this state until it is awakened by the host. If the host pulls the BBUS line low while temperature data is being clocked out, the device will not enter standby mode until completion of the data transfer. After entering standby mode, the device will remain in this mode until it is forced into active mode by the host. The transition from standby to active mode occurs when the host is no longer pulling the BBUS low.

Active Mode:

The host initiates active mode by enabling a weak pull up on the BBUS. In this mode, the EMC1203 and EMC1204 continuously convert temperature data. During the time that the device is actively converting a temperature, the BBUS is in tri-state mode, and the Host places a weak pull-up on the bus to prevent it from floating. After a conversion is completed, the device automatically clocks out the data from the most recent conversion to the host. When the data packet has been entirely clocked out, the BBUS returns to tri-state mode, and the ADC begins converting the next temperature sample. While BBUS is in tri-state mode, the host can command the device to standby mode.

Datasheet

3.4 Temperature Data Format

Temperature readings are coded in 2's complement format with a -64°C offset. This format spans from -63.875°C to +191.875°C with 0.125°C resolution. A temperature measurement outside this range is reported as either -63.875°C or +191.875°C. The host must add 64°C to calculate the actual temperature. [Table 3.1](#) shows example temperature readings and the value that will be reported on the BBUS.

Table 3.1 Temperature Data Format

ACTUAL TEMP. (°C)	2'S COMPLEMENT OF -64°C OFFSET	HEX
Diode Fault	100 0000 0000	400
-63.875	100 0000 0001	401
-63.000	100 0000 1000	408
-1.000	101 1111 1000	5F8
0.000	110 0000 0000	600
+0.125	110 0000 0001	601
+1.000	110 0000 1000	608

As shown in [Table 3.1](#), 400h is reserved for diode fault signaling which occurs when open or short conditions are detected between the external DP and DN pins.

3.5 Conversion Rate

The conversion rate can be controlled by the host. This is accomplished by periodically placing the device in standby as described in [Section 3.3](#).

Chapter 4 Package Outline

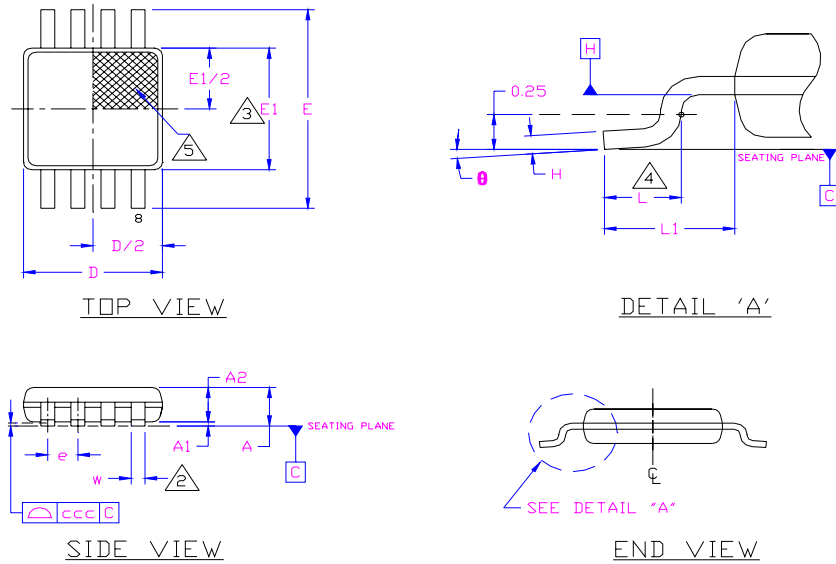

Figure 4.1 8-Pin MSOP Package Outline - 3x3mm Body 0.65mm Pitch

Table 4.1 8-Pin MSOP Package Parameters

	MIN	NOMINAL	MAX	REMARKS
A	0.80	~	1.10	Overall Package Height
A1	0.05	~	0.15	Standoff
A2	0.75	0.85	0.95	Body Thickness
D	2.80	3.00	3.20	X Body Size
E	4.65	4.90	5.15	Y Span
E1	2.80	~	3.20	Y body Size
H	0.08	~	0.23	Lead Foot Thickness
L	0.40	~	0.80	Lead Foot Length
L1	0.95 REF			Lead Length
e	0.65 BSC			Lead Pitch
θ	0°	~	8°	Lead Foot Angle
W	0.22	~	0.38	Lead Width
ccc	~	~	0.10	Coplanarity

Notes:

- Controlling Unit: millimeters.
- Tolerance on the true position of the leads is ± 0.065 mm maximum.
- Package body dimensions D and E1 do not include mold protrusion or flash. Dimensions D and E1 to be determined at datum plane H. Maximum mold protrusion or flash is 0.15mm (0.006 inches) per end, and 0.15mm (0.006 inches) per side.
- Dimension for foot length L measured at the gauge plane 0.25 mm above the seating plane.
- Details of pin 1 identifier are optional but must be located within the zone indicated.