

Digital transistors (built-in resistor)

DTC143TE / DTC143TUA / DTC143TKA

DTC143TSA

●Features

- 1) Built-in bias resistors enable the configuration of an inverter circuit without connecting external input resistors (see equivalent circuit).
- 2) The bias resistors consist of thin-film resistors with complete isolation to allow negative biasing of the input. They also have the advantage of almost completely eliminating parasitic effects.
- 3) Only the on/off conditions need to be set for operation, making device design easy.

●Structure

PNP digital transistor
(Built-in resistor type)

●Equivalent circuit

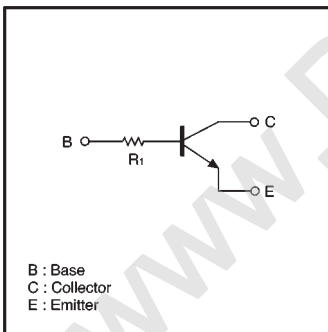

●External dimensions (Units: mm)

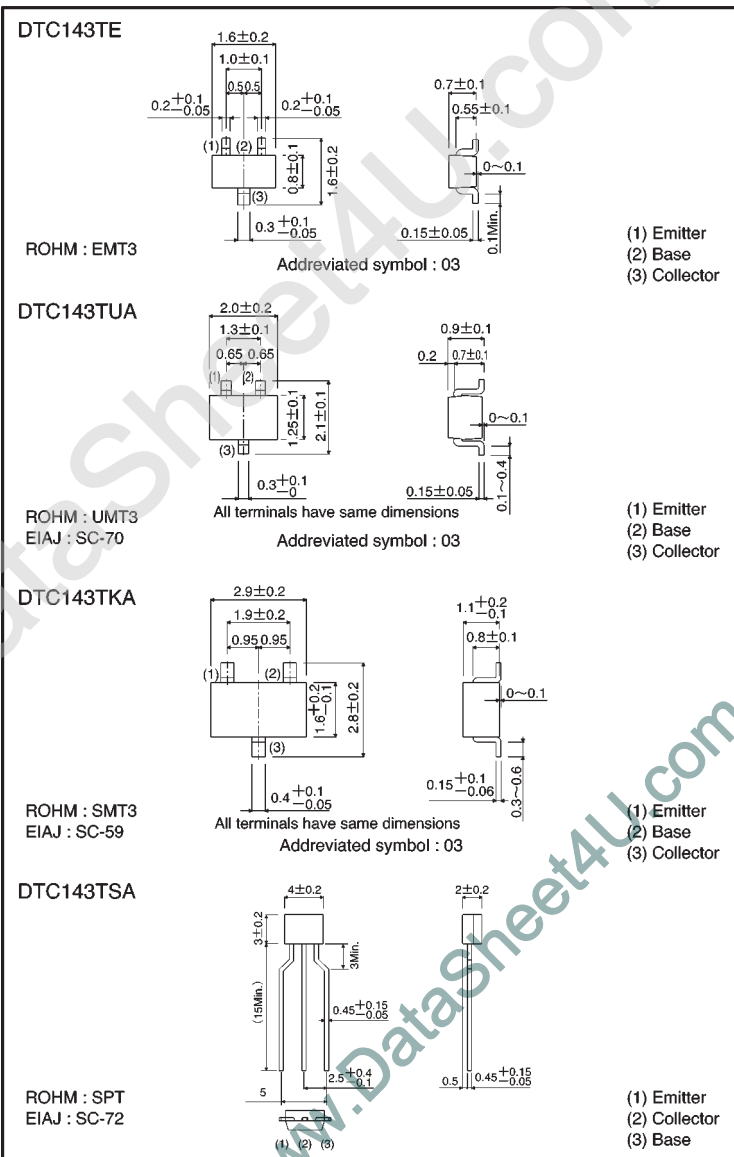

● Absolute maximum ratings (Ta = 25°C)

Parameter	Symbol	Limits (DTC143T□)				Unit
		E	UA	KA	SA	
Collector-base voltage	V _{CB0}	50				V
Collector-emitter voltage	V _{CEO}	50				V
Emitter-base voltage	V _{EB0}	5				V
Collector current	I _c	100				mA
Collector power dissipation	P _c	150	200	300		mW
Junction temperature	T _j	150				°C
Storage temperature	T _{stg}	-55~+150				°C

● Electrical characteristics (Ta = 25°C)

Parameter	Symbol	Min.	Typ.	Max.	Unit	Conditions
Collector-base breakdown voltage	BV _{CB0}	50	—	—	V	I _c =50 μA
Collector-emitter breakdown voltage	BV _{CEO}	50	—	—	V	I _c =1mA
Emitter-base breakdown voltage	BV _{EB0}	5	—	—	V	I _e =50 μA
Collector cutoff current	I _{CB0}	—	—	0.5	μA	V _{CB} =50V
Emitter cutoff current	I _{EB0}	—	—	0.5	μA	V _{EB} =4V
Collector-emitter saturation voltage	V _{CE(sat)}	—	—	0.3	V	I _c /I _b =5mA/0.25mA
DC current transfer ratio	h _{FE}	100	250	600	—	V _{CE} =5V, I _c =1mA
Input resistance	R _i	3.29	4.7	6.11	kΩ	—
Transition frequency	f _r	—	250	—	MHz	V _{CE} =10V, I _e =-5mA, f=100MHz *

* Transition frequency of mounted transistor

● Packaging specifications

Part No.	Package	EMT3	UMT3	SMT3	SPT
		Packaging type	Taping	Taping	Taping
	Code	TL	T106	T146	TP
	Basic ordering unit (pieces)	3000	3000	3000	5000
DTC143TE		○	—	—	—
DTC143TUA		—	○	—	—
DTC143TKA		—	—	○	—
DTC143TSA		—	—	—	○

● Electrical characteristic curves

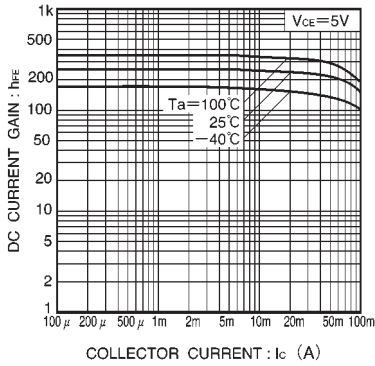

Fig.1 DC current gain vs. collector current

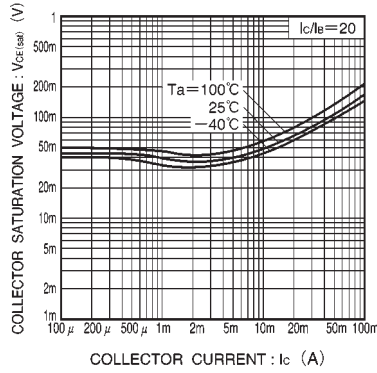

Fig.2 Collector-emitter saturation voltage vs. collector current