

Digital transistors (built-in resistors)

DTA113ZE / DTA113ZUA / DTA113ZKA / DTA113ZSA

●Features

- 1) The built-in bias resistor allows the configuration of an inverter circuit without connecting any external input resistors (see Equivalent circuit).
- 2) Each bias resistor is a thin-film resistor. Since they are completely insulated, the input can be positively biased. The insulation also eliminates most of the parasitic effects.
- 3) Circuit design is simplified since only the OFF and the ON conditions have to be set.

●Structure

PNP digital transistor
(with built in resistors).

●Equivalent circuit

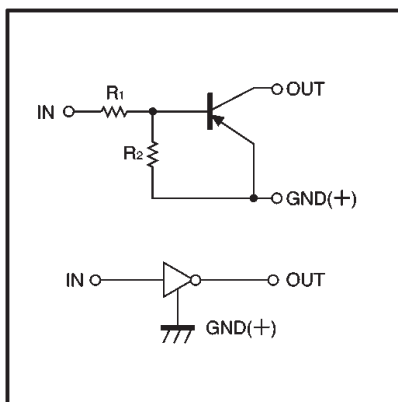

●External dimensions (Units: mm)

DTA113ZE

ROHM : EMT3
EIAJ : SC-70
Abbreviated symbol : E11

(1) GND
(2) IN
(3) OUT

DTA113ZUA

ROHM : UMT3
EIAJ : SC-70
Abbreviated symbol : 111

(1) GND
(2) IN
(3) OUT

DTA113ZKA

ROHM : SMT3
EIAJ : SC-59
Abbreviated symbol : E11

(1) GND
(2) IN
(3) OUT

DTA113ZSA

ROHM : SPT
EIAJ : SC-72

(1) GND
(2) OUT
(3) IN

●Absolute maximum ratings (Ta = 25°C)

Parameter	Symbol	Limits(DTA113Z□)				Unit
		E	UA	KA	SA	
Supply voltage	V _{CC}	-50				V
Input voltage	V _{IN}	-10~+5				V
Output current	I _o	-100				mA
	I _{C(Max.)}	-100				
Power dissipation	P _d	150	200	300	mW	
Junction temperature	T _J	150				°C
Storage temperature	T _{stg}	-55~+150				°C

●Electrical characteristics (Ta = 25°C)

Parameter	Symbol	Min.	Typ.	Max.	Unit	Conditions
Input voltage	V _{I(off)}	—	—	-0.3	V	V _{CC} = -5V, I _o = -100 μA
	V _{I(on)}	-3	—	—		V _o = -0.3V, I _o = -20mA
Output voltage	V _{O(on)}	—	—	-0.3	V	I _o /I _i = -10mA/-0.5mA
Input current	I _i	—	—	-7.2	mA	V _i = -5V
Output current	I _{O(off)}	—	—	-0.5	μA	V _{CC} = -50V, V _i = 0V
DC current gain	G _I	33	—	—	—	V _o = -5V, I _o = -5mA
Input resistance	R ₁	0.7	1	1.3	kΩ	—
Resistance ratio	R ₂ /R ₁	8	10	12	—	—
Transition frequency	f _r	—	250	—	MHz	V _{CE} = -10V, I _E = 5mA, f = 100MHz *

* Transition frequency of the device

●Packaging specifications

Part No.	Package	EMT3	UMT3	SMT3	SPT
	Package type	Taping	Taping	Taping	Taping
	Code	TL	T106	T146	TP
	Basic ordering unit (pieces)	3000	3000	3000	5000
DTA113ZE	○	—	—	—	—
DTA113ZUA	—	○	—	—	—
DTA113ZKA	—	—	○	—	—
DTA113ZSA	—	—	—	○	—

●Electrical characteristic curves

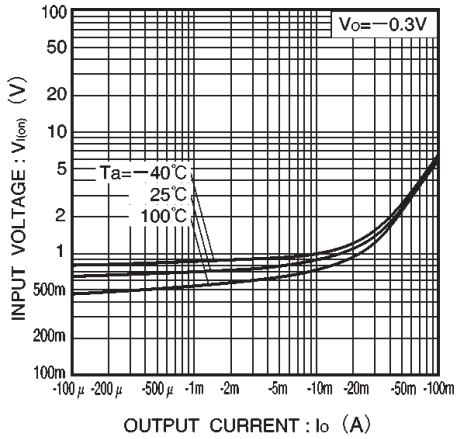

Fig.1 Input voltage vs. output current (ON characteristics)

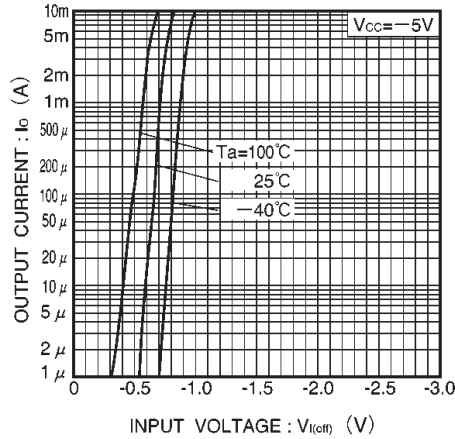

Fig.2 Output current vs. input voltage (OFF characteristics)

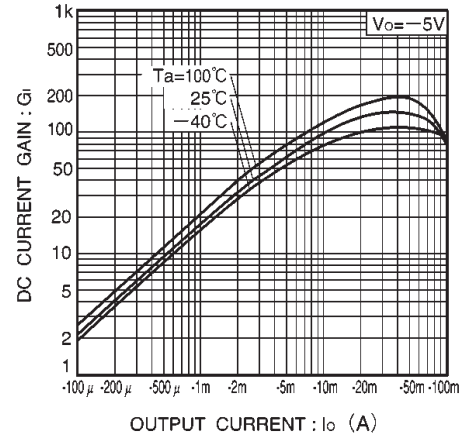

Fig.3 DC current gain vs. output current

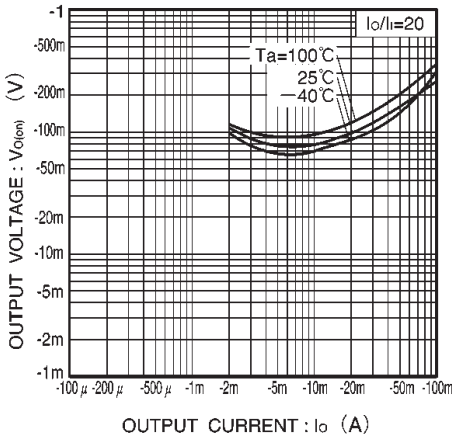

Fig.4 Output voltage vs. output current