

MC10EP16, MC100EP16

3.3V / 5V ECL Differential Receiver/Driver

Description

The EP16 is a world-class differential receiver/driver. The device is functionally equivalent to the EL16 and LVEL16 devices with higher performance capabilities. With output transition times significantly faster than the EL16 and LVEL16, the EP16 is ideally suited for interfacing with high frequency sources.

The V_{BB} pin, an internally generated voltage supply, is available to this device only. For single-ended input conditions, the unused differential input is connected to V_{BB} as a switching reference voltage. V_{BB} may also rebias AC coupled inputs. When used, decouple V_{BB} and V_{CC} via a 0.01 μ F capacitor and limit current sourcing or sinking to 0.5 mA. When not used, V_{BB} should be left open.

Under open input conditions (pulled to V_{EE}) internal input clamps will force the Q output LOW.

The 100 Series contains temperature compensation.

Features

- 220 ps Typical Propagation Delay
- Maximum Frequency > 4 GHz Typical
- PECL Mode Operating Range: $V_{CC} = 3.0$ V to 5.5 V with $V_{EE} = 0$ V
- NECL Mode Operating Range: $V_{CC} = 0$ V with $V_{EE} = -3.0$ V to -5.5 V
- Open Input Default State
- Safety Clamp on Inputs
- Q Output Will Default LOW with Inputs Open or at V_{EE}
- V_{BB} Output
- Pb-Free Packages are Available



ON Semiconductor®

<http://onsemi.com>

MARKING DIAGRAMS*

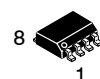

SOIC-8
D SUFFIX
CASE 751

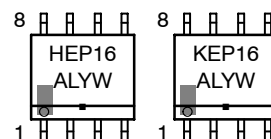

TSSOP-8
DT SUFFIX
CASE 948R

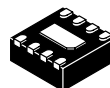
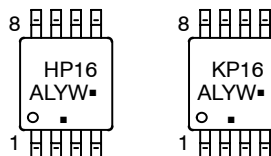

DFN8
MN SUFFIX
CASE 506AA

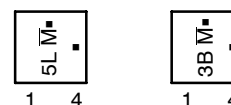

| | |
|----------------|-----------------------|
| H = MC10 | A = Assembly Location |
| K = MC100 | L = Wafer Lot |
| 5L = MC10 | Y = Year |
| 3B = MC100 | W = Work Week |
| M̄ = Date Code | ▪ = Pb-Free Package |

(Note: Microdot may be in either location)

*For additional marking information, refer to Application Note AND8002/D.

ORDERING INFORMATION

See detailed ordering and shipping information in the package dimensions section on page 8 of this data sheet.

MC10EP16, MC100EP16

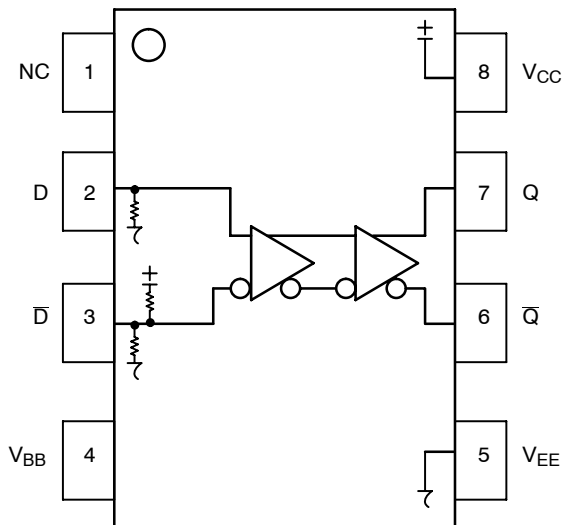

Table 1. PIN DESCRIPTION

| PIN | FUNCTION |
|------------------|---|
| D*, \bar{D} ** | ECL Data Inputs |
| Q, \bar{Q} | ECL Data Outputs |
| V _{BB} | Reference Voltage Output |
| V _{CC} | Positive Supply |
| V _{EE} | Negative Supply |
| NC | No Connect |
| EP | Exposed pad must be connected to a sufficient thermal conduit. Electrically connect to the most negative supply or leave floating open. |

* Pins will default LOW when left open.

** Pins will default to $V_{CC}/2$ when left open.

Figure 1. 8-Lead Pinout (Top View) and Logic Diagram

Table 2. ATTRIBUTES

| Characteristics | | Value | |
|---|------------------------|----------------------|---------|
| Internal Input Pulldown Resistor | | 75 k Ω | |
| Internal Input Pullup Resistor | | 37.5k Ω | |
| ESD Protection | Human Body Model | > 4 kV | |
| | Machine Model | > 200 V | |
| | Charged Device Model | > 2 kV | |
| Moisture Sensitivity, Indefinite Time Out of Drypack (Note 1) | Pb Pkg | Level 1 | Level 1 |
| | Pb-Free Pkg | Level 1 | Level 3 |
| SOIC-8 TSSOP-8 DFN8 | Level 1 | Level 1 | Level 1 |
| | Level 1 | Level 1 | Level 1 |
| | Level 1 | Level 1 | Level 1 |
| Flammability Rating | Oxygen Index: 28 to 34 | UL 94 V-0 @ 0.125 in | |
| Transistor Count | 167 Devices | | |
| Meets or exceeds JEDEC Spec EIA/JESD78 IC Latchup Test | | | |

1. For additional information, see Application Note AND8003/D.

MC10EP16, MC100EP16

Table 3. MAXIMUM RATINGS

| Symbol | Parameter | Condition 1 | Condition 2 | Rating | Unit |
|------------------|--|--|--|-------------|--------------|
| V _{CC} | PECL Mode Power Supply | V _{EE} = 0 V | | 6 | V |
| V _{EE} | NECL Mode Power Supply | V _{CC} = 0 V | | -6 | V |
| V _I | PECL Mode Input Voltage NECL Mode Input Voltage | V _{EE} = 0 V V _{CC} = 0 V | V _I ≤ V _{CC} V _I ≥ V _{EE} | 6 -6 | V V |
| I _{out} | Output Current | Continuous Surge | | 50 100 | mA mA |
| I _{BB} | V _{BB} Sink/Source | | | ± 0.5 | mA |
| T _A | Operating Temperature Range | | | -40 to +85 | °C |
| T _{stg} | Storage Temperature Range | | | -65 to +150 | °C |
| θ _{JA} | Thermal Resistance (Junction-to-Ambient) | 0 lfpm 500 lfpm | 8 SOIC 8 SOIC | 190 130 | °C/W °C/W |
| θ _{JC} | Thermal Resistance (Junction-to-Case) | Standard Board | 8 SOIC | 41 to 44 | °C/W |
| θ _{JA} | Thermal Resistance (Junction-to-Ambient) | 0 lfpm 500 lfpm | 8 TSSOP 8 TSSOP | 185 140 | °C/W °C/W |
| θ _{JC} | Thermal Resistance (Junction-to-Case) | Standard Board | 8 TSSOP | 41 to 44 | °C/W |
| θ _{JA} | Thermal Resistance (Junction-to-Ambient) | 0 lfpm 500 lfpm | DFN8 DFN8 | 129 84 | °C/W °C/W |
| T _{sol} | Wave Solder Pb Pb-Free | | | 265 265 | °C |

Stresses exceeding Maximum Ratings may damage the device. Maximum Ratings are stress ratings only. Functional operation above the Recommended Operating Conditions is not implied. Extended exposure to stresses above the Recommended Operating Conditions may affect device reliability.

Table 4. 10EP DC CHARACTERISTICS, PECL V_{CC} = 3.3 V, V_{EE} = 0 V (Note 2)

| Symbol | Characteristic | -40°C | | | 25°C | | | 85°C | | | Unit |
|--------------------|--|---------|-------------|------|-------------|------|------|-------------|------|------|------|
| | | Min | Typ | Max | Min | Typ | Max | Min | Typ | Max | |
| I _{EE} | Power Supply Current | 20 | 24 | 31 | 20 | 24 | 31 | 20 | 24 | 32 | mA |
| V _{OH} | Output HIGH Voltage (Note 3) | 2165 | 2290 | 2415 | 2230 | 2355 | 2480 | 2290 | 2415 | 2540 | mV |
| V _{OL} | Output LOW Voltage (Note 3) | 1365 | 1490 | 1615 | 1430 | 1555 | 1680 | 1490 | 1615 | 1740 | mV |
| V _{IH} | Input HIGH Voltage (Single-Ended) | 2090 | | 2415 | 2155 | | 2480 | 2215 | | 2540 | mV |
| V _{IL} | Input LOW Voltage (Single-Ended) | 1365 | | 1690 | 1430 | | 1755 | 1490 | | 1815 | mV |
| V _{BB} | Output Voltage Reference | 1790 | 1890 | 1990 | 1855 | 1955 | 2055 | 1915 | 2015 | 2115 | mV |
| V _{IHCMR} | Input HIGH Voltage Common Mode Range (Differential Configuration) (Note 4) | 2.0 | | 3.3 | 2.0 | | 3.3 | 2.0 | | 3.3 | V |
| I _{IH} | Input HIGH Current | | | 150 | | | 150 | | | 150 | μA |
| I _{IL} | Input LOW Current | D D̄ | 0.5 -150 | | 0.5 -150 | | | 0.5 -150 | | | μA |

NOTE: Device will meet the specifications after thermal equilibrium has been established when mounted in a test socket or printed circuit board with maintained transverse airflow greater than 500 lfpm. Electrical parameters are guaranteed only over the declared operating temperature range. Functional operation of the device exceeding these conditions is not implied. Device specification limit values are applied individually under normal operating conditions and not valid simultaneously.

- Input and output parameters vary 1:1 with V_{CC}. V_{EE} can vary +0.3 V to -2.2 V.
- All loading with 50 Ω to V_{CC} - 2.0 V.
- V_{IHCMR} min varies 1:1 with V_{EE}. V_{IHCMR} max varies 1:1 with V_{CC}. The V_{IHCMR} range is referenced to the most positive side of the differential input signal.

MC10EP16, MC100EP16

Table 5. 10EP DC CHARACTERISTICS, PECL $V_{CC} = 5.0\text{ V}$, $V_{EE} = 0\text{ V}$ (Note 5)

| Symbol | Characteristic | -40°C | | | 25°C | | | 85°C | | | Unit |
|-------------|--|--------------------------------|------|------|-------------|------|------|-------------|------|------|---------------|
| | | Min | Typ | Max | Min | Typ | Max | Min | Typ | Max | |
| I_{EE} | Power Supply Current | 20 | 24 | 31 | 20 | 24 | 31 | 20 | 24 | 32 | mA |
| V_{OH} | Output HIGH Voltage (Note 6) | 3865 | 3990 | 4115 | 3930 | 4055 | 4180 | 3990 | 4115 | 4240 | mV |
| V_{OL} | Output LOW Voltage (Note 6) | 3065 | 3190 | 3315 | 3130 | 3255 | 3380 | 3190 | 3315 | 3440 | mV |
| V_{IH} | Input HIGH Voltage (Single-Ended) | 3790 | | 4115 | 3855 | | 4180 | 3915 | | 4240 | mV |
| V_{IL} | Input LOW Voltage (Single-Ended) | 3065 | | 3390 | 3130 | | 3455 | 3190 | | 3515 | mV |
| V_{BB} | Output Voltage Reference | 3490 | 3590 | 3690 | 3555 | 3655 | 3755 | 3615 | 3715 | 3815 | mV |
| V_{IHCMR} | Input HIGH Voltage Common Mode Range (Differential Configuration) (Note 7) | 2.0 | | 5.0 | 2.0 | | 5.0 | 2.0 | | 5.0 | V |
| I_{IH} | Input HIGH Current | | | 150 | | | 150 | | | 150 | μA |
| I_{IL} | Input LOW Current | \overline{D} 0.5 D -150 | | | 0.5 -150 | | | 0.5 -150 | | | μA |

NOTE: Device will meet the specifications after thermal equilibrium has been established when mounted in a test socket or printed circuit board with maintained transverse airflow greater than 500 lfm. Electrical parameters are guaranteed only over the declared operating temperature range. Functional operation of the device exceeding these conditions is not implied. Device specification limit values are applied individually under normal operating conditions and not valid simultaneously.

5. Input and output parameters vary 1:1 with V_{CC} . V_{EE} can vary +2.0 V to -0.5 V.

6. All loading with 50 Ω to $V_{CC} - 2.0\text{ V}$.

7. V_{IHCMR} min varies 1:1 with V_{EE} , V_{IHCMR} max varies 1:1 with V_{CC} . The V_{IHCMR} range is referenced to the most positive side of the differential input signal.

Table 6. 10EP DC CHARACTERISTICS, NECL $V_{CC} = 0\text{ V}$; $V_{EE} = -5.5\text{ V}$ to -3.0 V (Note 8)

| Symbol | Characteristic | -40°C | | | 25°C | | | 85°C | | | Unit |
|-------------|---|--------------------------------|-------|-------|----------------|-------|-------|----------------|-------|-------|---------------|
| | | Min | Typ | Max | Min | Typ | Max | Min | Typ | Max | |
| I_{EE} | Power Supply Current | 20 | 24 | 31 | 20 | 24 | 31 | 20 | 24 | 32 | mA |
| V_{OH} | Output HIGH Voltage (Note 9) | -1135 | -1010 | -885 | -1070 | -945 | -820 | -1010 | -885 | -760 | mV |
| V_{OL} | Output LOW Voltage (Note 9) | -1935 | -1810 | -1685 | -1870 | -1745 | -1620 | -1810 | -1685 | -1560 | mV |
| V_{IH} | Input HIGH Voltage (Single-Ended) | -1210 | | -885 | -1145 | | -820 | -1085 | | -760 | mV |
| V_{IL} | Input LOW Voltage (Single-Ended) | -1935 | | -1610 | -1870 | | -1545 | -1810 | | -1485 | mV |
| V_{BB} | Output Voltage Reference | -1510 | -1410 | -1310 | -1445 | -1345 | -1245 | -1385 | -1285 | -1185 | mV |
| V_{IHCMR} | Input HIGH Voltage Common Mode Range (Differential Configuration) (Note 10) | $V_{EE} + 2.0$ | | 0.0 | $V_{EE} + 2.0$ | | 0.0 | $V_{EE} + 2.0$ | | 0.0 | V |
| I_{IH} | Input HIGH Current | | | 150 | | | 150 | | | 150 | μA |
| I_{IL} | Input LOW Current | \overline{D} 0.5 D -150 | | | 0.5 -150 | | | 0.5 -150 | | | μA |

NOTE: Device will meet the specifications after thermal equilibrium has been established when mounted in a test socket or printed circuit board with maintained transverse airflow greater than 500 lfm. Electrical parameters are guaranteed only over the declared operating temperature range. Functional operation of the device exceeding these conditions is not implied. Device specification limit values are applied individually under normal operating conditions and not valid simultaneously.

8. Input and output parameters vary 1:1 with V_{CC} .

9. All loading with 50 Ω to $V_{CC} - 2.0\text{ V}$.

10. V_{IHCMR} min varies 1:1 with V_{EE} , V_{IHCMR} max varies 1:1 with V_{CC} . The V_{IHCMR} range is referenced to the most positive side of the differential input signal.

MC10EP16, MC100EP16

Table 7. 100EP DC CHARACTERISTICS, PECL $V_{CC} = 3.3\text{ V}$, $V_{EE} = 0\text{ V}$ (Note 11)

| Symbol | Characteristic | -40°C | | | 25°C | | | 85°C | | | Unit |
|-------------|---|---------------------|-------------|------|-------------|------|------|-------------|------|------|---------------|
| | | Min | Typ | Max | Min | Typ | Max | Min | Typ | Max | |
| I_{EE} | Power Supply Current | 17 | 25 | 36 | 17 | 25 | 36 | 22 | 26 | 38 | mA |
| V_{OH} | Output HIGH Voltage (Note 12) | 2155 | 2280 | 2405 | 2155 | 2280 | 2405 | 2155 | 2280 | 2405 | mV |
| V_{OL} | Output LOW Voltage (Note 12) | 1355 | 1480 | 1605 | 1355 | 1480 | 1605 | 1355 | 1480 | 1605 | mV |
| V_{IH} | Input HIGH Voltage (Single-Ended) | 2075 | | 2420 | 2075 | | 2420 | 2075 | | 2420 | mV |
| V_{IL} | Input LOW Voltage (Single-Ended) | 1355 | | 1675 | 1355 | | 1675 | 1355 | | 1675 | mV |
| V_{BB} | Output Voltage Reference | 1775 | 1875 | 1975 | 1775 | 1875 | 1975 | 1775 | 1875 | 1975 | mV |
| V_{IHCMR} | Input HIGH Voltage Common Mode Range (Differential Configuration) (Note 13) | 2.0 | | 3.3 | 2.0 | | 3.3 | 2.0 | | 3.3 | V |
| I_{IH} | Input HIGH Current | | | 150 | | | 150 | | | 150 | μA |
| I_{IL} | Input LOW Current | $\frac{D}{\bar{D}}$ | 0.5 -150 | | 0.5 -150 | | | 0.5 -150 | | | μA |

NOTE: Device will meet the specifications after thermal equilibrium has been established when mounted in a test socket or printed circuit board with maintained transverse airflow greater than 500 lfm. Electrical parameters are guaranteed only over the declared operating temperature range. Functional operation of the device exceeding these conditions is not implied. Device specification limit values are applied individually under normal operating conditions and not valid simultaneously.

11. Input and output parameters vary 1:1 with V_{CC} . V_{EE} can vary +0.3 V to -2.2 V.

12. All loading with 50 Ω to $V_{CC} - 2.0\text{ V}$.

13. V_{IHCMR} min varies 1:1 with V_{EE} . V_{IHCMR} max varies 1:1 with V_{CC} . The V_{IHCMR} range is referenced to the most positive side of the differential input signal.

Table 8. 100EP DC CHARACTERISTICS, PECL $V_{CC} = 5.0\text{ V}$, $V_{EE} = 0\text{ V}$ (Note 14)

| Symbol | Characteristic | -40°C | | | 25°C | | | 85°C | | | Unit |
|-------------|---|---------------------|-------------|------|-------------|------|------|-------------|------|------|---------------|
| | | Min | Typ | Max | Min | Typ | Max | Min | Typ | Max | |
| I_{EE} | Power Supply Current | 17 | 25 | 36 | 17 | 25 | 36 | 22 | 26 | 38 | mA |
| V_{OH} | Output HIGH Voltage (Note 15) | 3855 | 3980 | 4105 | 3855 | 3980 | 4105 | 3855 | 3980 | 4105 | mV |
| V_{OL} | Output LOW Voltage (Note 15) | 3055 | 3180 | 3305 | 3055 | 3180 | 3305 | 3055 | 3180 | 3305 | mV |
| V_{IH} | Input HIGH Voltage (Single-Ended) | 3775 | | 4120 | 3775 | | 4120 | 3775 | | 4120 | mV |
| V_{IL} | Input LOW Voltage (Single-Ended) | 3055 | | 3375 | 3055 | | 3375 | 3055 | | 3375 | mV |
| V_{BB} | Output Voltage Reference | 3475 | 3575 | 3675 | 3475 | 3575 | 3675 | 3475 | 3575 | 3675 | mV |
| V_{IHCMR} | Input HIGH Voltage Common Mode Range (Differential Configuration) (Note 16) | 2.0 | | 5.0 | 2.0 | | 5.0 | 2.0 | | 5.0 | V |
| I_{IH} | Input HIGH Current | | | 150 | | | 150 | | | 150 | μA |
| I_{IL} | Input LOW Current | $\frac{D}{\bar{D}}$ | 0.5 -150 | | 0.5 -150 | | | 0.5 -150 | | | μA |

NOTE: Device will meet the specifications after thermal equilibrium has been established when mounted in a test socket or printed circuit board with maintained transverse airflow greater than 500 lfm. Electrical parameters are guaranteed only over the declared operating temperature range. Functional operation of the device exceeding these conditions is not implied. Device specification limit values are applied individually under normal operating conditions and not valid simultaneously.

14. Input and output parameters vary 1:1 with V_{CC} . V_{EE} can vary +2.0 V to -0.5 V.

15. All loading with 50 Ω to $V_{CC} - 2.0\text{ V}$.

16. V_{IHCMR} min varies 1:1 with V_{EE} . V_{IHCMR} max varies 1:1 with V_{CC} . The V_{IHCMR} range is referenced to the most positive side of the differential input signal.

MC10EP16, MC100EP16

Table 9. 100EP DC CHARACTERISTICS, NECL $V_{CC} = 0\text{ V}$; $V_{EE} = -5.5\text{ V}$ to -3.0 V (Note 17)

| Symbol | Characteristic | -40°C | | | 25°C | | | 85°C | | | Unit |
|-------------|---|----------------|-------|-------|----------------|-------|-------|----------------|-------|-------|---------------|
| | | Min | Typ | Max | Min | Typ | Max | Min | Typ | Max | |
| I_{EE} | Power Supply Current | 17 | 25 | 36 | 17 | 25 | 36 | 22 | 26 | 38 | mA |
| V_{OH} | Output HIGH Voltage (Note 18) | -1145 | -1020 | -895 | -1145 | -1020 | -895 | -1145 | -1020 | -895 | mV |
| V_{OL} | Output LOW Voltage (Note 18) | -1945 | -1820 | -1695 | -1945 | -1820 | -1695 | -1945 | -1820 | -1695 | mV |
| V_{IH} | Input HIGH Voltage (Single-Ended) | -1225 | | -880 | -1225 | | -880 | -1225 | | -880 | mV |
| V_{IL} | Input LOW Voltage (Single-Ended) | -1945 | | -1625 | -1945 | | -1625 | -1945 | | -1625 | mV |
| V_{BB} | Output Voltage Reference | -1525 | -1425 | -1325 | -1525 | -1425 | -1325 | -1525 | -1425 | -1325 | mV |
| V_{IHCMR} | Input HIGH Voltage Common Mode Range (Differential Configuration) (Note 19) | $V_{EE} + 2.0$ | | 0.0 | $V_{EE} + 2.0$ | | 0.0 | $V_{EE} + 2.0$ | | 0.0 | V |
| I_{IH} | Input HIGH Current | | | 150 | | | 150 | | | 150 | μA |
| I_{IL} | Input LOW Current D | 0.5 -150 | | | 0.5 -150 | | | 0.5 -150 | | | μA |

NOTE: Device will meet the specifications after thermal equilibrium has been established when mounted in a test socket or printed circuit board with maintained transverse airflow greater than 500 lfm. Electrical parameters are guaranteed only over the declared operating temperature range. Functional operation of the device exceeding these conditions is not implied. Device specification limit values are applied individually under normal operating conditions and not valid simultaneously.

17. Input and output parameters vary 1:1 with V_{CC} .

18. All loading with $50\ \Omega$ to $V_{CC} - 2.0\text{ V}$.

19. V_{IHCMR} min varies 1:1 with V_{EE} , V_{IHCMR} max varies 1:1 with V_{CC} . The V_{IHCMR} range is referenced to the most positive side of the differential input signal.

Table 10. AC CHARACTERISTICS $V_{CC} = 0\text{ V}$; $V_{EE} = -3.0\text{ V}$ to -5.5 V or $V_{CC} = 3.0\text{ V}$ to 5.5 V ; $V_{EE} = 0\text{ V}$ (Note 20)

| Symbol | Characteristic | -40°C | | | 25°C | | | 85°C | | | Unit |
|--------------------------|--|-------|-----|------|------|-----|------|------|-----|------|------|
| | | Min | Typ | Max | Min | Typ | Max | Min | Typ | Max | |
| f_{max} | Maximum Frequency (Figure 2) | | > 4 | | | > 4 | | | > 4 | | GHz |
| t_{PLH} , t_{PHL} | Propagation Delay to Output Differential | 150 | 220 | 280 | 150 | 220 | 280 | 160 | 240 | 300 | ps |
| t_{SKEW} | Duty Cycle Skew (Note 21) | | 5.0 | 20 | | 5.0 | 20 | | 5.0 | 20 | ps |
| t_{JITTER} | Cycle-to-Cycle Jitter (Figure 2) | | 0.2 | < 1 | | 0.2 | < 1 | | 0.2 | < 1 | ps |
| V_{PP} | Input Voltage Swing (Differential Configuration) | 150 | 800 | 1200 | 150 | 800 | 1200 | 150 | 800 | 1200 | mV |
| t_r , t_f | Output Rise/Fall Times (20% – 80%) Q, \bar{Q} | 70 | 120 | 170 | 80 | 130 | 180 | 100 | 150 | 200 | ps |

NOTE: Device will meet the specifications after thermal equilibrium has been established when mounted in a test socket or printed circuit board with maintained transverse airflow greater than 500 lfm. Electrical parameters are guaranteed only over the declared operating temperature range. Functional operation of the device exceeding these conditions is not implied. Device specification limit values are applied individually under normal operating conditions and not valid simultaneously.

20. Measured using a 750 mV source, 50% duty cycle clock source. All loading with $50\ \Omega$ to $V_{CC} - 2.0\text{ V}$.

21. Skew is measured between outputs under identical transitions. Duty cycle skew is defined only for differential operation when the delays are measured from the cross point of the inputs to the cross point of the outputs.

MC10EP16, MC100EP16

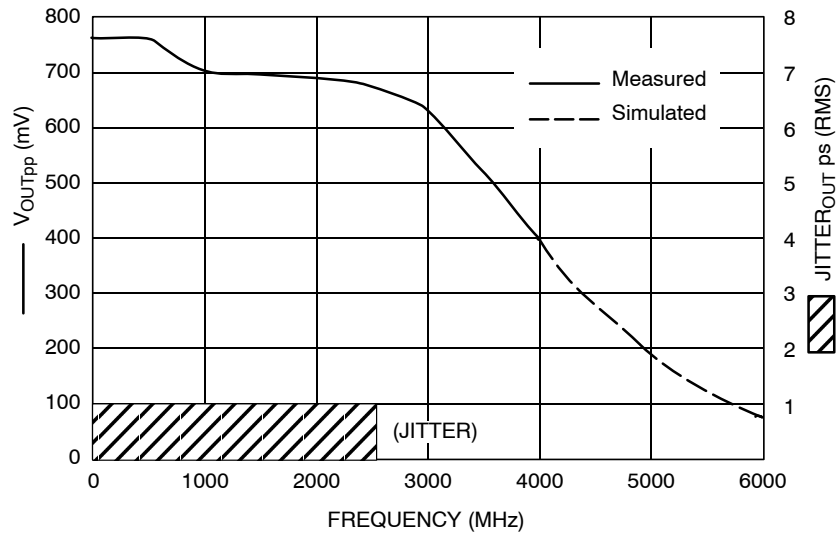

Figure 2. $F_{max}/Jitter$

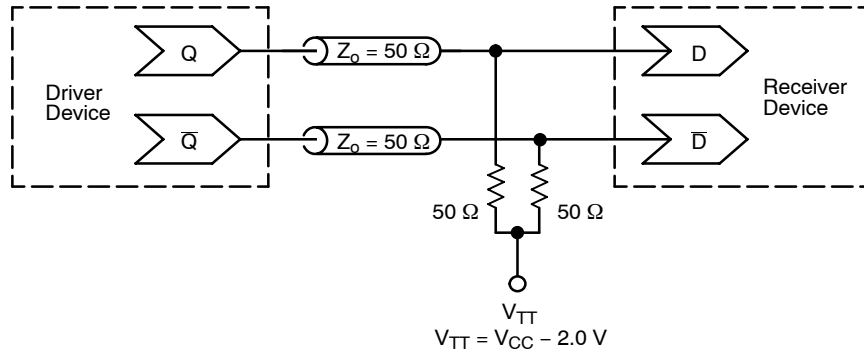

Figure 3. Typical Termination for Output Driver and Device Evaluation (See Application Note AND8020/D – Termination of ECL Logic Devices.)

MC10EP16, MC100EP16

ORDERING INFORMATION

| Device | Package | Shipping† |
|----------------|----------------------|--------------------|
| MC10EP16D | SOIC-8 | 98 Units / Rail |
| MC10EP16DG | SOIC-8 (Pb-Free) | 98 Units / Rail |
| MC10EP16DR2 | SOIC-8 | 2500 / Tape & Reel |
| MC10EP16DR2G | SOIC-8 (Pb-Free) | 2500 / Tape & Reel |
| MC10EP16DT | TSSOP-8 | 100 Units / Rail |
| MC10EP16DTG | TSSOP-8 (Pb-Free) | 100 Units / Rail |
| MC10EP16DTR2 | TSSOP-8 | 2500 / Tape & Reel |
| MC10EP16DTR2G | TSSOP-8 (Pb-Free) | 2500 / Tape & Reel |
| MC10EP16MNR4 | DFN8 | 1000 / Tape & Reel |
| MC10EP16MNR4G | DFN8 (Pb-Free) | 1000 / Tape & Reel |
| MC100EP16D | SOIC-8 | 98 Units / Rail |
| MC100EP16DG | SOIC-8 (Pb-Free) | 98 Units / Rail |
| MC100EP16DR2 | SOIC-8 | 2500 / Tape & Reel |
| MC100EP16DR2G | SOIC-8 (Pb-Free) | 2500 / Tape & Reel |
| MC100EP16DT | TSSOP-8 | 100 Units / Rail |
| MC100EP16DTG | TSSOP-8 (Pb-Free) | 100 Units / Rail |
| MC100EP16DTR2 | TSSOP-8 | 2500 / Tape & Reel |
| MC100EP16DTR2G | TSSOP-8 (Pb-Free) | 2500 / Tape & Reel |
| MC100EP16MNR4 | DFN8 | 1000 / Tape & Reel |
| MC100EP16MNR4G | DFN8 (Pb-Free) | 1000 / Tape & Reel |

†For information on tape and reel specifications, including part orientation and tape sizes, please refer to our Tape and Reel Packaging Specifications Brochure, BRD8011/D.

Resource Reference of Application Notes

- AN1405/D** – ECL Clock Distribution Techniques
- AN1406/D** – Designing with PECL (ECL at +5.0 V)
- AN1503/D** – ECLinPS™ I/O SPICE Modeling Kit
- AN1504/D** – Metastability and the ECLinPS Family
- AN1568/D** – Interfacing Between LVDS and ECL
- AN1672/D** – The ECL Translator Guide
- AND8001/D** – Odd Number Counters Design
- AND8002/D** – Marking and Date Codes
- AND8020/D** – Termination of ECL Logic Devices
- AND8066/D** – Interfacing with ECLinPS
- AND8090/D** – AC Characteristics of ECL Devices

MC10EP16, MC100EP16

PACKAGE DIMENSIONS

SOIC-8 NB
CASE 751-07
ISSUE AH

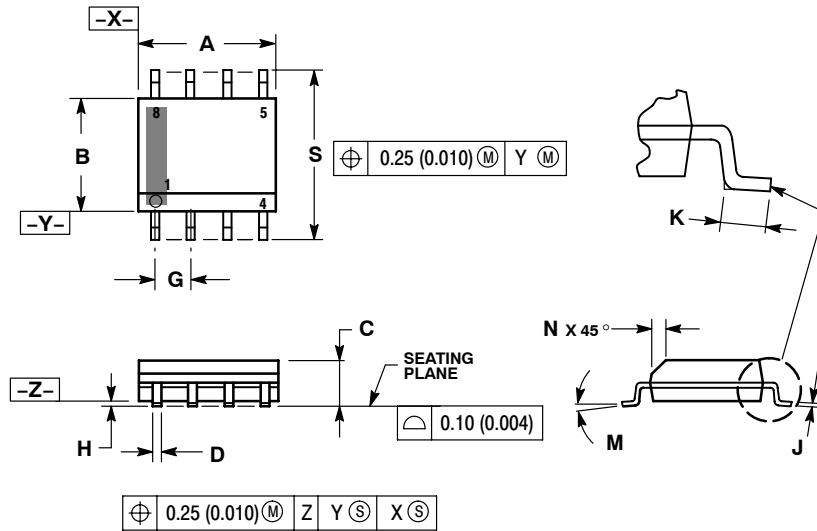

NOTES:

1. DIMENSIONING AND TOLERANCING PER ANSI Y14.5M, 1982.
2. CONTROLLING DIMENSION: MILLIMETER.
3. DIMENSION A AND B DO NOT INCLUDE MOLD PROTRUSION.
4. MAXIMUM MOLD PROTRUSION 0.15 (0.006) PER SIDE.
5. DIMENSION D DOES NOT INCLUDE DAMBAR PROTRUSION. ALLOWABLE DAMBAR PROTRUSION SHALL BE 0.127 (0.005) TOTAL IN EXCESS OF THE D DIMENSION AT MAXIMUM MATERIAL CONDITION.
6. 751-01 THRU 751-06 ARE OBSOLETE. NEW STANDARD IS 751-07.

| DIM | MILLIMETERS | | INCHES | |
|-----|-------------|------|-----------|-------|
| | MIN | MAX | MIN | MAX |
| A | 4.80 | 5.00 | 0.189 | 0.197 |
| B | 3.80 | 4.00 | 0.150 | 0.157 |
| C | 1.35 | 1.75 | 0.053 | 0.069 |
| D | 0.33 | 0.51 | 0.013 | 0.020 |
| G | 1.27 BSC | | 0.050 BSC | |
| H | 0.10 | 0.25 | 0.004 | 0.010 |
| J | 0.19 | 0.25 | 0.007 | 0.010 |
| K | 0.40 | 1.27 | 0.016 | 0.050 |
| M | 0° | 8° | 0° | 8° |
| N | 0.25 | 0.50 | 0.010 | 0.020 |
| S | 5.80 | 6.20 | 0.228 | 0.244 |

SOLDERING FOOTPRINT*

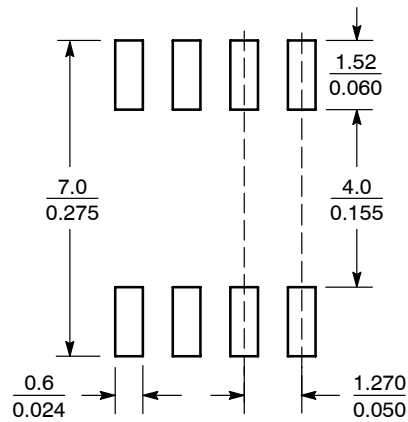

SCALE 6:1 ($\frac{\text{mm}}{\text{inches}}$)

*For additional information on our Pb-Free strategy and soldering details, please download the ON Semiconductor Soldering and Mounting Techniques Reference Manual, SOLDERRM/D.

MC10EP16, MC100EP16

PACKAGE DIMENSIONS

TSSOP-8
DT SUFFIX
 PLASTIC TSSOP PACKAGE
 CASE 948R-02
 ISSUE A

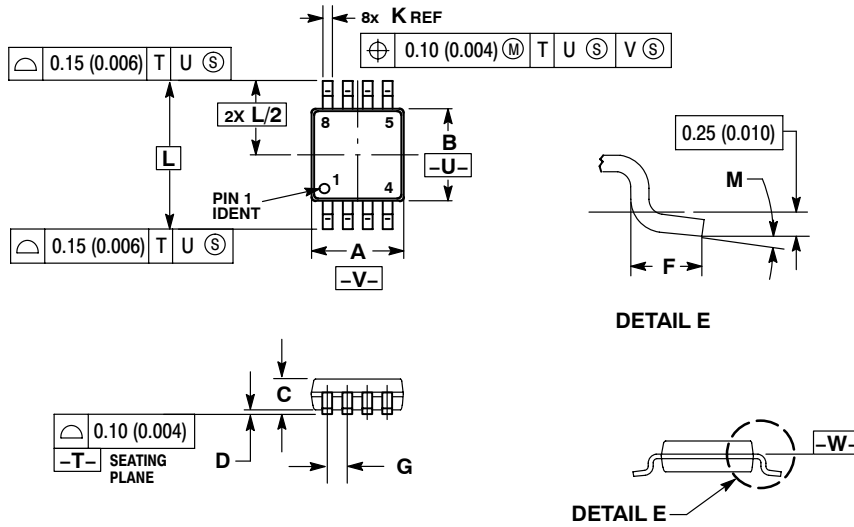

NOTES:

1. DIMENSIONING AND TOLERANCING PER ANSI Y14.5M, 1982.
2. CONTROLLING DIMENSION: MILLIMETER.
3. DIMENSION A DOES NOT INCLUDE MOLD FLASH. PROTRUSIONS OR GATE BURRS SHALL NOT EXCEED 0.15 (0.006) PER SIDE.
4. DIMENSION B DOES NOT INCLUDE INTERLEAD FLASH OR PROTRUSION. INTERLEAD FLASH OR PROTRUSION SHALL NOT EXCEED 0.25 (0.010) PER SIDE.
5. TERMINAL NUMBERS ARE SHOWN FOR REFERENCE ONLY.
6. DIMENSION A AND B ARE TO BE DETERMINED AT DATUM PLANE -W-.

| DIM | MILLIMETERS | | INCHES | |
|-----|-------------|------|-----------|-------|
| | MIN | MAX | MIN | MAX |
| A | 2.90 | 3.10 | 0.114 | 0.122 |
| B | 2.90 | 3.10 | 0.114 | 0.122 |
| C | 0.80 | 1.10 | 0.031 | 0.043 |
| D | 0.05 | 0.15 | 0.002 | 0.006 |
| F | 0.40 | 0.70 | 0.016 | 0.028 |
| G | 0.65 BSC | | 0.026 BSC | |
| K | 0.25 | 0.40 | 0.010 | 0.016 |
| L | 4.90 BSC | | 0.193 BSC | |
| M | 0° | 6° | 0° | 6° |

MC10EP16, MC100EP16

PACKAGE DIMENSIONS

DFN8
CASE 506AA-01
ISSUE D

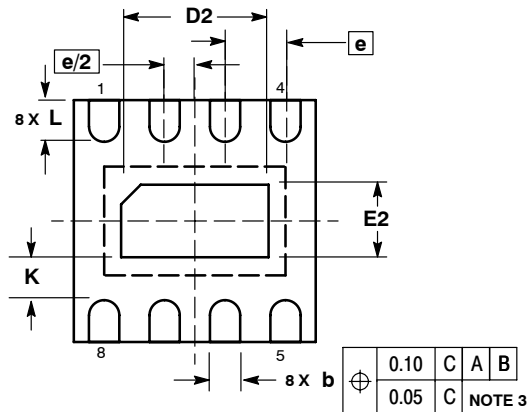
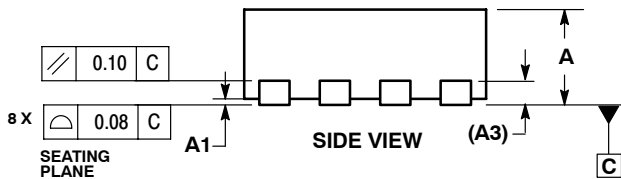
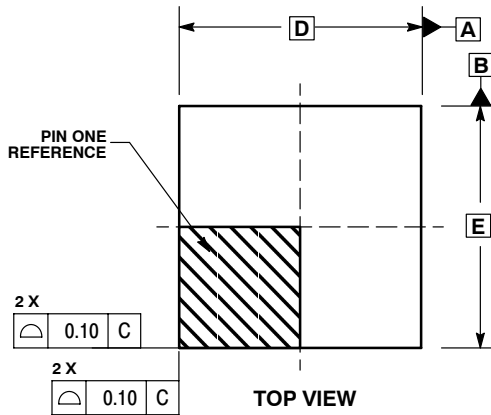

NOTES:

1. DIMENSIONING AND TOLERANCING PER ASME Y14.5M, 1994 .
2. CONTROLLING DIMENSION: MILLIMETERS.
3. DIMENSION b APPLIES TO PLATED TERMINAL AND IS MEASURED BETWEEN 0.25 AND 0.30 MM FROM TERMINAL.
4. COPLANARITY APPLIES TO THE EXPOSED PAD AS WELL AS THE TERMINALS.

| DIM | MILLIMETERS | |
|-----|-------------|------|
| | MIN | MAX |
| A | 0.80 | 1.00 |
| A1 | 0.00 | 0.05 |
| A3 | 0.20 REF | |
| b | 0.20 | 0.30 |
| D | 2.00 BSC | |
| D2 | 1.10 | 1.30 |
| E | 2.00 BSC | |
| E2 | 0.70 | 0.90 |
| e | 0.50 BSC | |
| K | 0.20 | --- |
| L | 0.25 | 0.35 |

ECLinPS is a trademark of Semiconductor Components Industries, LLC (SCILLC).

ON Semiconductor and  are registered trademarks of Semiconductor Components Industries, LLC (SCILLC). SCILLC reserves the right to make changes without further notice to any products herein. SCILLC makes no warranty, representation or guarantee regarding the suitability of its products for any particular purpose, nor does SCILLC assume any liability arising out of the application or use of any product or circuit, and specifically disclaims any and all liability, including without limitation special, consequential or incidental damages. "Typical" parameters which may be provided in SCILLC data sheets and/or specifications can and do vary in different applications and actual performance may vary over time. All operating parameters, including "Typicals" must be validated for each customer application by customer's technical experts. SCILLC does not convey any license under its patent rights nor the rights of others. SCILLC products are not designed, intended, or authorized for use as components in systems intended for surgical implant into the body, or other applications intended to support or sustain life, or for any other application in which the failure of the SCILLC product could create a situation where personal injury or death may occur. Should Buyer purchase or use SCILLC products for any such unintended or unauthorized application, Buyer shall indemnify and hold SCILLC and its officers, employees, subsidiaries, affiliates, and distributors harmless against all claims, costs, damages, and expenses, and reasonable attorney fees arising out of, directly or indirectly, any claim of personal injury or death associated with such unintended or unauthorized use, even if such claim alleges that SCILLC was negligent regarding the design or manufacture of the part. SCILLC is an Equal Opportunity/Affirmative Action Employer. This literature is subject to all applicable copyright laws and is not for resale in any manner.

PUBLICATION ORDERING INFORMATION

LITERATURE FULFILLMENT:
Literature Distribution Center for ON Semiconductor
P.O. Box 5163, Denver, Colorado 80217 USA
Phone: 303-675-2175 or 800-344-3860 Toll Free USA/Canada
Fax: 303-675-2176 or 800-344-3867 Toll Free USA/Canada
Email: orderlit@onsemi.com

N. American Technical Support: 800-282-9855 Toll Free
USA/Canada
Europe, Middle East and Africa Technical Support:
Phone: 421 33 790 2910
Japan Customer Focus Center
Phone: 81-3-5773-3850

ON Semiconductor Website: www.onsemi.com
Order Literature: <http://www.onsemi.com/orderlit>
For additional information, please contact your local Sales Representative

MC10EP16/D