

UTC2SB766A PNP EPITAXIAL SILICON TRANSISTOR

LOW FREQUENCY OUTPUT AMPLIFICATION

FEATURES

- *Large collector power dissipation P_c .
- *Mini Power type package, allowing downsizing of the equipment and automatic insertion through the tape packing and the magazine packing.

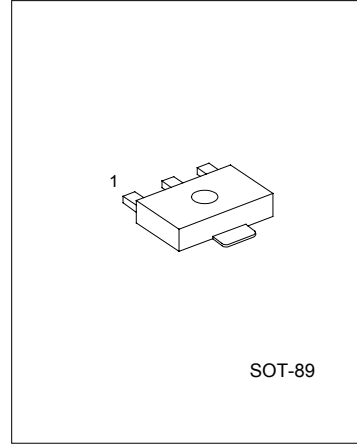

1:EMITTER 2:COLLECTOR 3:BASE

ABSOLUTE MAXIMUM RATINGS ($T_a=25^{\circ}\text{C}$)

PARAMETER	SYMBOL	RATING	UNIT
Collector-Base Voltage	V_{CBO}	-60	V
Collector-Emitter Voltage	V_{CEO}	-50	V
Emitter-Base Voltage	V_{EBO}	-5	V
Collector Current	I_c	-1	A
Peak Collector Current	I_{cp}	-1.5	A
Collector Power Dissipation	P_c^*	1	W
Junction Temperature	T_j	150	$^{\circ}\text{C}$
Storage Temperature	T_{STG}	-55 ~ +150	$^{\circ}\text{C}$

*Printed circuit board :Copper foil area of 1cm^2 or more, and the board thickness of 1.7mm for the collector portion.

ELECTRICAL CHARACTERISTICS ($T_a=25^{\circ}\text{C}$, unless otherwise specified)

PARAMETER	SYMBOL	TEST CONDITIONS	MIN	TYP	MAX	UNIT
Collector Base Voltage	V_{CBO}	$I_c = -10 \mu\text{A}, I_E = 0$	-60			V
Collector Emitter Voltage	V_{CEO}	$I_c = -2\text{mA}, I_B = 0$	-50			V
Emitter Base Voltage	V_{EBO}	$I_E = -10 \mu\text{A}, I_C = 0$	-5			V
Collector Cut-Off Current	I_{CBO}	$V_{CB} = -20\text{V}, I_E = 0$			-0.1	μA
DC Current Transfer Ratio	h_{FE1}	$V_{CE} = -10\text{V}, I_c = -500\text{mA}^*$	85		340	
	h_{FE2}	$V_{CE} = -5\text{V}, I_c = -1\text{A}^*$	50			
Collector-Emitter Saturation Voltage	$V_{CE(sat)}$	$I_c = -500\text{mA}, I_B = -50\text{mA}^*$		-0.2	-0.4	V
Base-Emitter Saturation Voltage	$V_{BE(sat)}$	$I_c = -500\text{mA}, I_B = -50\text{mA}^*$		-0.85	-1.2	V
Transition Frequency	f_T	$V_{CB} = -10\text{V}, I_E = 50\text{mA}, f = 200\text{MHz}$		200		MHz
Output Capacitance	C_{ob}	$V_{CB} = -10\text{V}, I_E = 0, f = 1\text{MHz}$		20	30	pF

*Pulse measurement

CLASSIFICATION OF h_{FE1}

RANK	Q	R	S
RANGE	85-170	120-240	170-340

UTC UNISONIC TECHNOLOGIES CO. LTD

1

QW-R208-028,A

ELECTRICAL CHARACTERISTICS CURVES

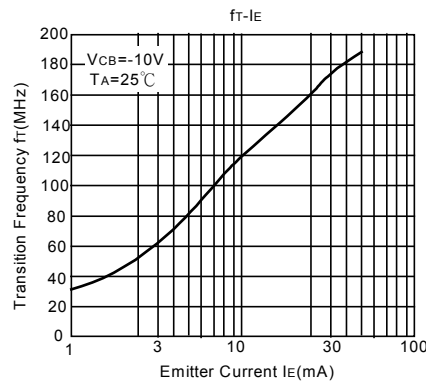
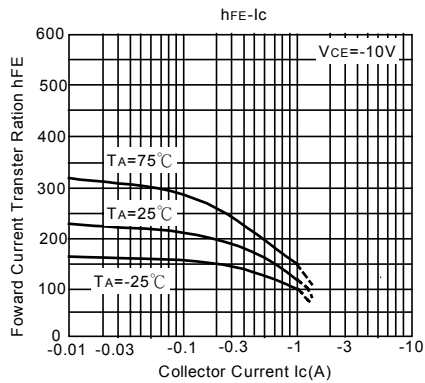
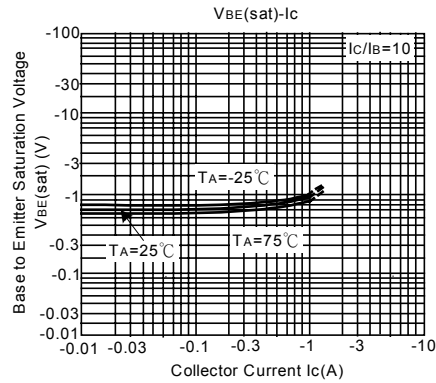
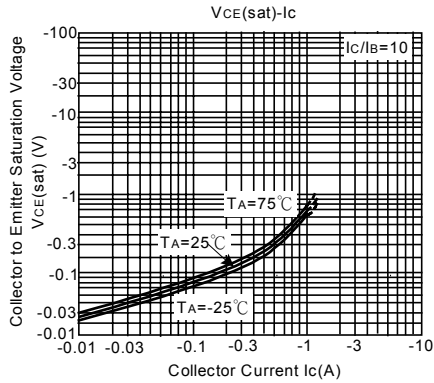
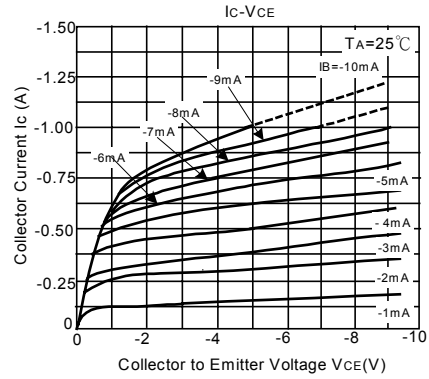
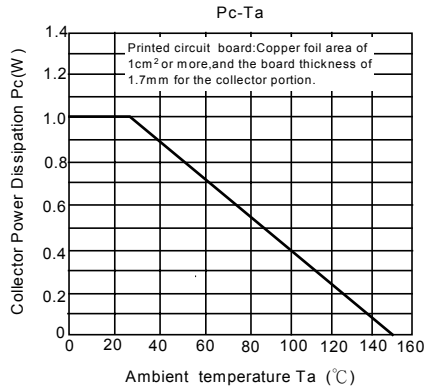

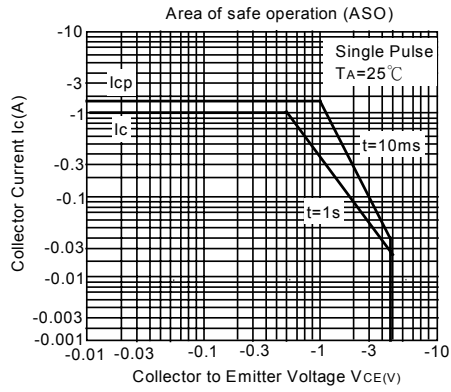
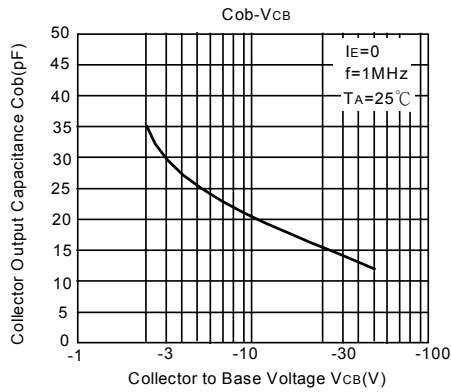

UTC assumes no responsibility for equipment failures that result from using products at values that exceed, even momentarily, rated values (such as maximum ratings, operating condition ranges, or other parameters) listed in products specifications of any and all UTC products described or contained herein. UTC products are not designed for use in life support appliances, devices or systems where malfunction of these products can be reasonably expected to result in personal injury. Reproduction in whole or in part is prohibited without the prior written consent of the copyright owner. The information presented in this document does not form part of any quotation or contract, is believed to be accurate and reliable and may be changed without notice.