

## TO-252 Plastic-Encapsulated Transistors

### 2SD1899-Z TRANSISTOR (NPN)

#### FEATURES

Power dissipation

$$P_{CM}: 2 \text{ W (Tamb=25°C)}$$

Collector current

$$I_{CM}: 3 \text{ A}$$

Collector-base voltage

$$V_{(BR)CBO}: 60 \text{ V}$$

Operating and storage junction temperature range

$$T_J, T_{stg}: -55°C \text{ to } +150°C$$

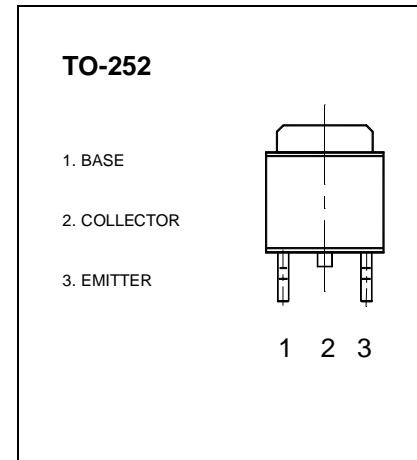

#### ELECTRICAL CHARACTERISTICS (Tamb=25°C unless otherwise specific)

Parameter	Symbol	Test conditions	MIN	TYP	MAX	UNIT
Collector-base breakdown voltage	$V_{(BR)CBO}$	$I_C=100\mu A, I_E=0$	60			V
Collector-emitter breakdown voltage	$V_{(BR)CEO}$	$I_C=1mA, I_B=0$	60			V
Emitter-base breakdown voltage	$V_{(BR)EBO}$	$I_E=100\mu A, I_C=0$	7			V
Collector cut-off current	$I_{CBO}$	$V_{CB}=60V, I_E=0$			10	$\mu A$
Emitter cut-off current	$I_{EBO}$	$V_{EB}=7V, I_C=0$			10	$\mu A$
DC current gain	$h_{FE(1)}$	$V_{CE}=2V, I_C=200mA$	60			
	$h_{FE(2)}$	$V_{CE}=2V, I_C=600mA$	100		400	
	$h_{FE(3)}$	$V_{CE}=2V, I_C=2A$	50			
Collector-emitter saturation voltage	$V_{CE(sat)}$	$I_C=1.5A, I_B=150mA$			0.25	V
Base-emitter saturation voltage	$V_{BE(sat)}$	$I_C=1.5A, I_B=150mA$			1.2	V
Transition frequency	$f_T$	$V_{CE}=5V, I_C=1.5A$		120		MHz
Collector output capacitance	$C_{ob}$	$V_{CB}=10V, I_E=0, f=1MHz$		30		pF
Switching Time	Turn on Time	$t_{on}$		0.5		$\mu s$
	Storage Time	$t_{stg}$	$V_{CC}=30V, I_C=1A, I_{B1}=-I_{B2}=-0.05A$	2.0		
	Fall Time	$t_f$		0.5		

#### CLASSIFICATION OF $h_{FE(1)}$

Rank	M	L	K
Range	100-200	160-320	200-400