

SIEMENS

ICs for Consumer Electronics

ADC with Built in Antialiasing filter and
Clock generation UnitS
ABACUS
SDA 9206

Data Sheet 1999-02-10

Edition 1999-02-10

This edition was realized using the software system FrameMaker®

Published by Siemens AG, Bereich Halbleiter, Marketing-Kommunikation, Balanstraße 73, 81541 München

© Siemens AG 1999.
All Rights Reserved.

Attention please!

As far as patents or other rights of third parties are concerned, liability is only assumed for components, not for applications, processes and circuits implemented within components or assemblies.

The information describes the type of component and shall not be considered as assured characteristics.

Terms of delivery and rights to change design reserved.

For questions on technology, delivery and prices please contact the Semiconductor Group Offices in Germany or the Siemens Companies and Representatives worldwide (see address list).

Due to technical requirements components may contain dangerous substances. For information on the types in question please contact your nearest Siemens Office, Semiconductor Group.

Siemens AG is an approved CECC manufacturer.

Packing

Please use the recycling operators known to you. We can also help you – get in touch with your nearest sales office. By agreement we will take packing material back, if it is sorted. You must bear the costs of transport.

For packing material that is returned to us unsorted or which we are not obliged to accept, we shall have to invoice you for any costs incurred.

Components used in life-support devices or systems must be expressly authorized for such purpose!

Critical components¹ of the Semiconductor Group of Siemens AG, may only be used in life-support devices or systems² with the express written approval of the Semiconductor Group of Siemens AG.

- 1 A critical component is a component used in a life-support device or system whose failure can reasonably be expected to cause the failure of that life-support device or system, or to affect its safety or effectiveness of that device or system.
- 2 Life support devices or systems are intended (a) to be implanted in the human body, or (b) to support and/or maintain and sustain human life. If they fail, it is reasonable to assume that the health of the user may be endangered.

SIEMENS

ICs for Consumer Electronics

ADC with Built in Antialiasing filter and
Clock generation UnitS
ABACUS
SDA 9206

Data Sheet 1999-02-10

SDA 9206		
Revision History:		Current Version: 1999-02-10
Previous Version:		
Page (in previous Version)	Page (in current Version)	Subjects (major changes since last revision)
21	21	Update of Table 2 concerning Straight Binary

Data Classification

Maximum Ratings

Maximum ratings are absolute ratings; exceeding only one of these values may cause irreversible damage to the integrated circuit.

Recommended Operating Conditions

Under this conditions the functions given in the circuit description are fulfilled. Nominal conditions specify mean values expected over the production spread and are the proposed values for interface and application. If not stated otherwise, nominal values will apply at $T_A=25^{\circ}\text{C}$ and the nominal supply voltage.

Characteristics

The listed characteristics are ensured over the operating range of the integrated circuit.

Edition 1999-02-10

Published by Siemens AG, Semiconductor Group
 Copyright © Siemens AG 1999. All rights reserved.
 Terms of delivery and right to change design reserved.

Table of Contents		Page
1	Overview	6
1.1	Features	6
1.2	General Description	7
1.3	Pin Configuration	8
1.4	Pin Description	9
1.5	Internal Pin Configuration	11
1.6	Block Diagram	14
2	System Description	15
2.1	A/D Converter for YUV Inputs	15
2.1.1	Introduction	15
2.1.2	Input Signal Amplification, Prefiltering	15
2.1.3	Clamping	16
2.1.4	Digital Decimation Filters for YUV	16
2.2	Data Output Formatter	18
2.2.1	Output Coding for Straight Binary / Two's Complement Mode	20
2.3	Clock Sync Generation	21
2.3.1	Horizontal PLL (HPLL)	21
2.3.2	Vertical Sync Processing (only available for 1fh mode)	23
2.3.3	Pulse Generation	25
2.3.4	Miscellaneous Circuit Sections	26
2.4	I ² C Bus	27
2.4.1	I ² C-Bus Address	27
2.4.2	I ² C-Bus Format	27
2.4.3	I ² C-Bus Commands	28
2.4.4	Detailed Description	29
2.4.5	Read Mode	42
3	Absolute Maximum Ratings	44
3.1	Recommended Operating Conditions	45
3.2	Characteristics (Assuming Recommended Operating Conditions)	47
4	Application Information	50
5	Waveforms	52
5.1	Timing Diagram Data Input/Output Referenced to the Clock CLK1	52
5.2	Timing Diagram Clock Skew CLK2 - CLK1	52
5.3	Programmable Data Output Delay: DAT_OUT: Pins PAQ7...0, PBQ7...0, BLN, HS, H1I1, H2I2 and VS	53
6	Package Outlines	54

ADC with Built in Antialiasing filter and Clock generation Units ABACUS

SDA 9206

Preliminary Data

CMOS

1 Overview

1.1 Features

- Three equivalent CMOS A/D converters on chip
- 30 MHz sampling rate
- 8-Bit resolution
- No external sample & hold required
- Internal clamping circuits for each of the ADCs
- Internal amplification of input signals can be set by I²C Bus
- Internal pre-filtering of analog input signals
- High performance decimation filters
- Two data sampling modes (4:2:2 and 4:1:1)
- 3 output data interfaces
 - CCIR 656 interface (8 wires)
 - Parallel data interface (2 x 8 wires)
 - Quasi Parallel data interface (8 + 4 wires)
- Overflow and underflow I²C status bits
- On-chip sync and clock generation
- Separate SYNC input with clamping for sync and clock generation (max. line frequency of SYNC input: 38 kHz)
- positive and negative polarity of SYNC signal (switchable by I²C Bus)
- Lock-in behavior can be set via I²C Bus
- Frequency generator function possible with digitally adjustable frequency
- Clock generation for single and double line input frequencies supported (1fh / 2fh mode)
- Vertical noise suppression and 50/60 Hz detection (for 1fh mode only)

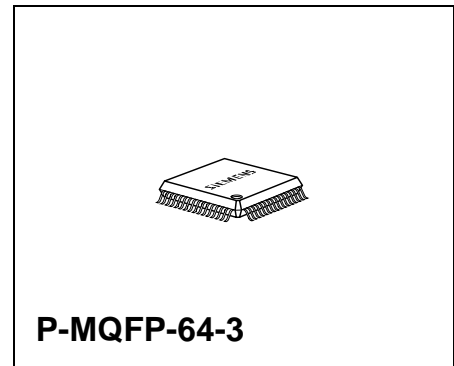

Type	Ordering Code	Package
SDA 9206	Q67101-H5185-A704	P-MQFP-64-3

- I²C-Bus interface
- P-MQFP-64-3
- 5 V supply voltage for input signals
- 3.3 V or 5 V supply voltage for output signals

1.2 General Description

The SDA 9206 is a single monolithic IC containing three separate 8-Bit A/D converters for video (YUV) applications and a clock sync generator which is delivering the sample clock for the A/D converters. It utilizes an advanced VLSI 0.5 μm CMOS process providing 30 MHz sampling rates at 8-Bits.

The YUV processing consists of following functional blocks:

- Analog input buffers and clamping circuits
- Three 30 MHz A/D converters
- Digital decimation filters
- Delay compensation in Y-path
- Output formatter and buffer

The clock sync generator consists essentially of the following functional blocks:

- Analog clamping
- 7-Bit A/D converter
- Sync processor with digital horizontal PLL, vertical sync processor and pulse generator
- Clock generator with discrete timing oscillator, D/A converter, analog PLL and divider, as well as a crystal oscillator

1.3 Pin Configuration

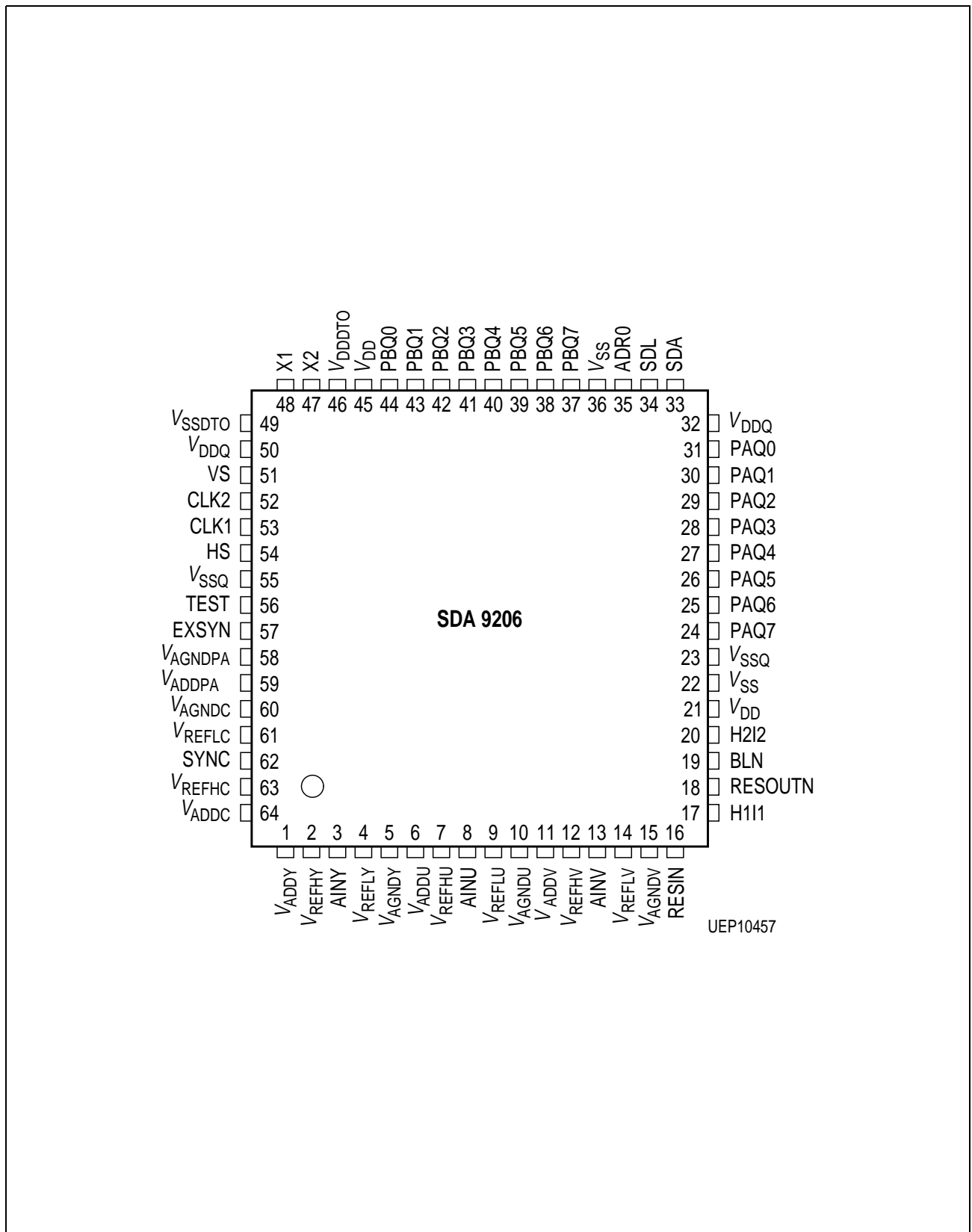

Figure 1

1.4 Pin Description

Pin No.	Symbol	Type	Description
22, 36	V_{SS}	S	Supply ground (V_{SS}) for digital parts
21, 45	V_{DD}	S	Supply voltage (V_{DD}) for digital parts
23, 55	V_{SSQ}	S	Supply ground for output stages and input stages
32, 50	V_{DDQ}	S	Supply voltage for output stages and input stages (3.3 V / 5 V)
1	V_{ADDY}	S	Analog positive supply voltage of ADC AINY (5 V)
2	V_{REFHY}		Reference voltage high of ADC AINY (4.2 V)
3	AINY	I/ana	Analog voltage input of ADC AINY input range selectable via I ² C Bus (subaddress 11 _H , YAMP)
4	V_{REFLY}		Reference voltage low of ADC AINY (2.2 V)
5	V_{AGNDY}	S	Analog ground of ADC AINY
6	V_{ADDU}	S	Analog positive supply voltage of ADC AINU (5 V)
7	V_{REFHU}		Reference voltage high of ADC AINU (4.2 V)
8	AINU	I/ana	Analog voltage input of ADC AINU input range selectable via I ² C Bus (subaddress 12 _H , UAMP)
9	V_{REFLU}		Reference voltage low of ADC AINU (2.2 V)
10	V_{AGNDU}	S	Analog ground of ADC AINU
11	V_{ADDV}	S	Analog positive supply voltage of ADC AINV (5 V)
12	V_{REFHV}		Reference voltage high of ADC AINV (4.2 V)
13	AINV	I/ana	Analog voltage input of ADC AINV input range selectable via I ² C Bus (subaddress 12 _H , VAMP)
14	V_{REFLV}		Reference voltage low of ADC AINV (2.2 V)
15	V_{AGNDV}	S	Analog ground of ADC AINV
16	RESIN	I/TTL/pu	Reset input signal: active low
17	H111	Q/TTL	Pin function defined by I ² C Bus: Line frequent pulse output or programmable digital control output
18	RESOUTN	Q/TTL	Reset output signal: active low; reset for other ICs
19	BLN	Q/TTL	Blanking signal output, high level indicates active video line

1.4 Pin Description (cont'd)

Pin No.	Symbol	Type	Description
20	H2I2	Q/TTL	Pin function defined by I ² C Bus: Line frequent pulse output or programmable digital control output
24 ... 31	PAQ7 ... 0	Q/TTL	Data output Port A (see Data Format)
33	SDA	IQ	I ² C-Bus data line
34	SCL	I	I ² C-Bus clock line
35	ADR0	I/TTL/pd	I ² C-Chip select
37 ... 44	PBQ7... 0	Q/TTL	Data output port B (see Data Format)
46	V _{DDDTO}	S	Positive supply voltage of DTO (5 V)
47	X2	Q/ana	Crystal connection
48	X1	I/ana	Crystal connection (clock input)
49	V _{SSDTO}	S	Ground of DTO
51	VS	Q/TTL	Vertical sync pulse output
52	CLK2	Q/TTL	Clock out: tristate / 6.75 / 13.5 / 27 MHz; selectable via I ² C
53	CLK1	Q/TTL	Clock out: tristate / 6.75 / 13.5 / 27 MHz; selectable via I ² C
54	HS	Q/TTL	Horizontal sync pulse output
56	TEST	I/TTL/pd	Input signal for test mode selection (0 V: no test mode selected) Leave unconnected or connect to V _{SS}
57	EXSYN	I/TTL/pd	Input signal for test mode selection (0 V: no test mode selected) Leave unconnected or connect to V _{SS}
58	V _{AGNDPA}		Analog ground of analog PLL and DACs
59	V _{ADDPA}		Analog positive supply voltage of analog PLL and DACs (5 V)
60	V _{AGNDC}		Analog ground of ADC SYNC
61	V _{REFLC}		Reference voltage low of ADC SYNC (2.2 V)
62	SYNC	I/ana	SYNC input Input range selectable via I ² C Bus (subaddress 11 _H , SYNAMP)

1.4 Pin Description (cont'd)

Pin No.	Symbol	Type	Description
63	V_{REFHC}		Reference voltage high of ADC SYNC (4.2 V)
64	V_{ADDC}		Analog positive supply voltage of ADC SYNC (5 V)

S: supply, I: input, Q: output, TTL: digital (TTL)
 ana: analog, pu: internal pullup-circuit, pd: internal pulldown-circuit

1.5 Internal Pin Configuration

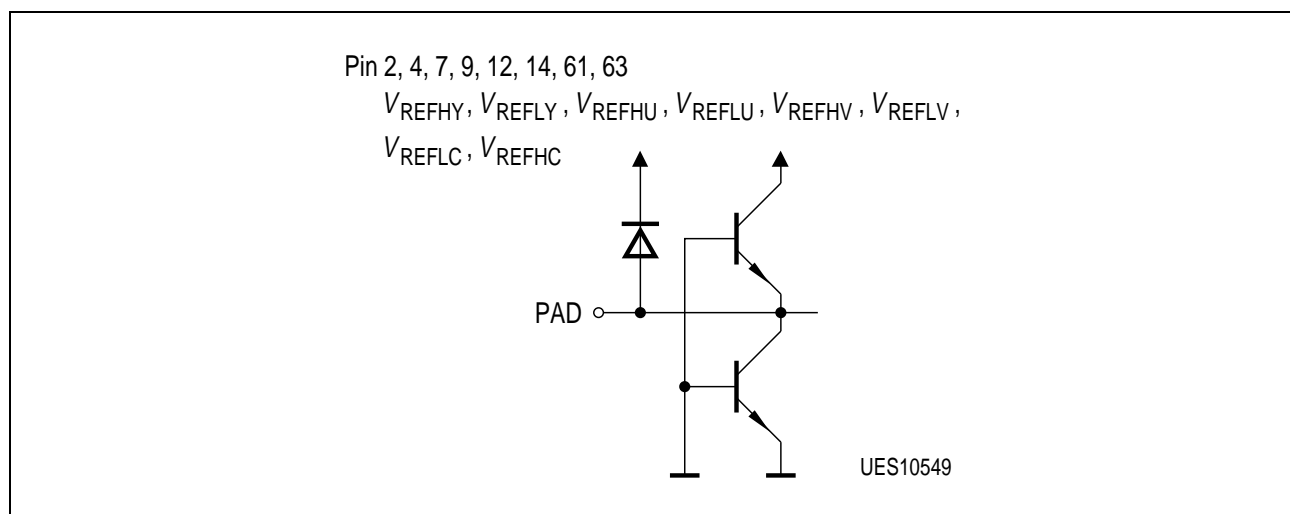

Figure 2

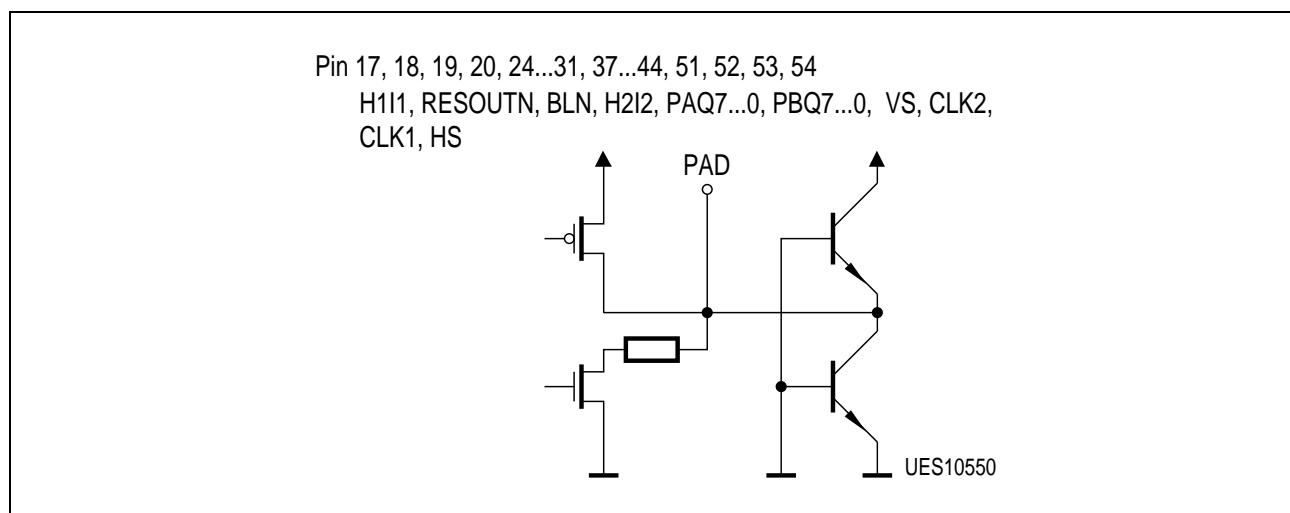

Figure 3

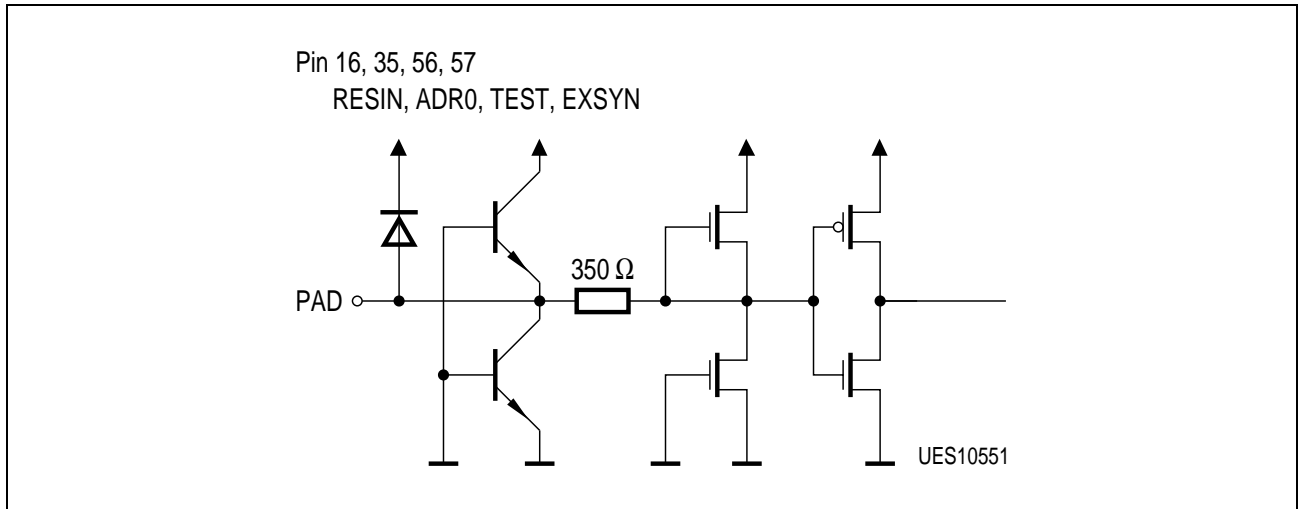

Figure 4

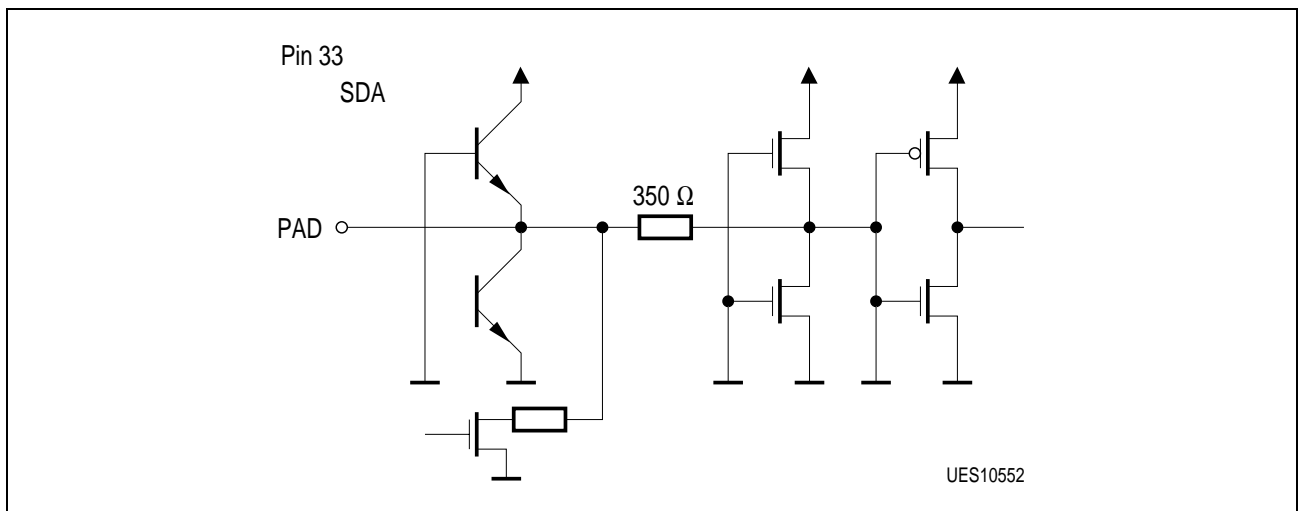

Figure 5

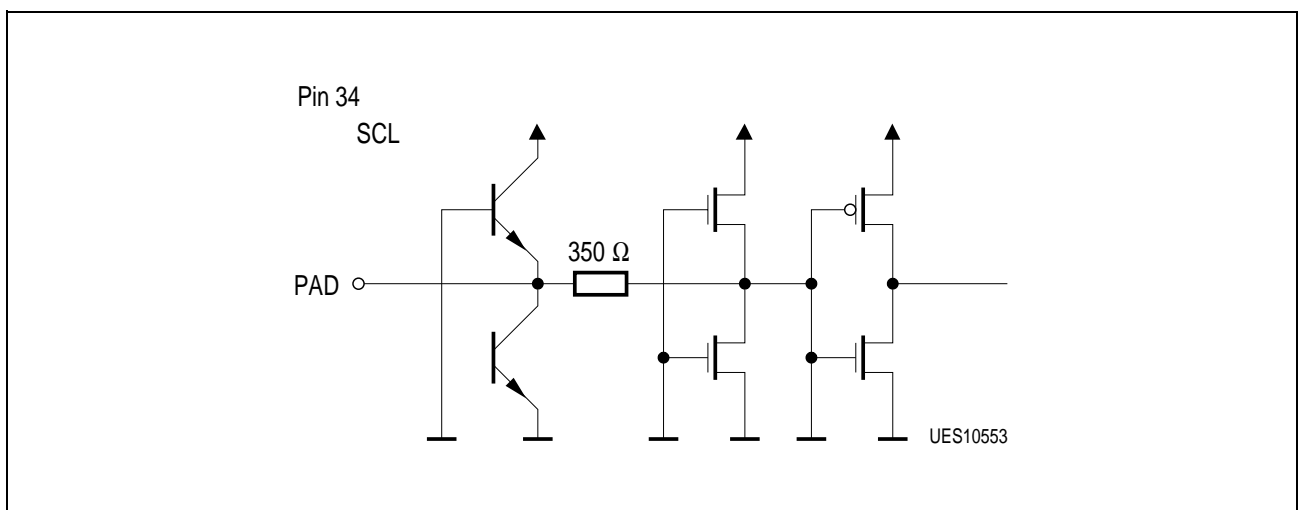

Figure 6

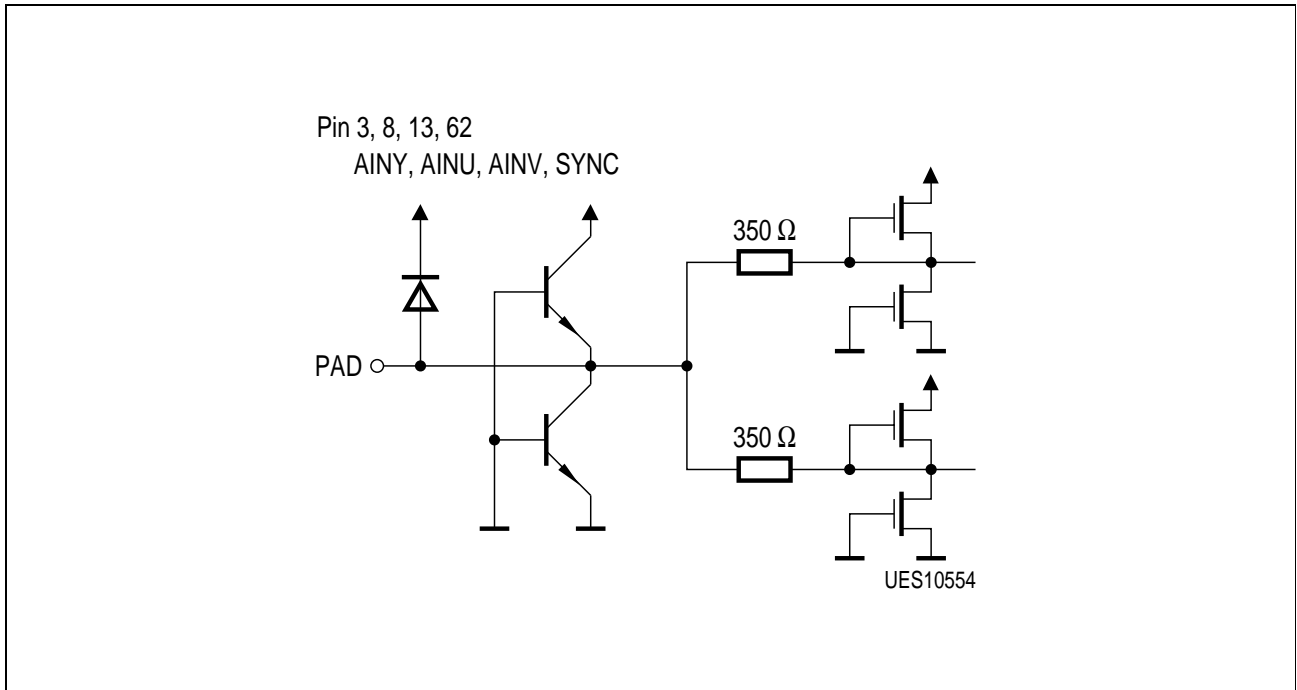

Figure 7

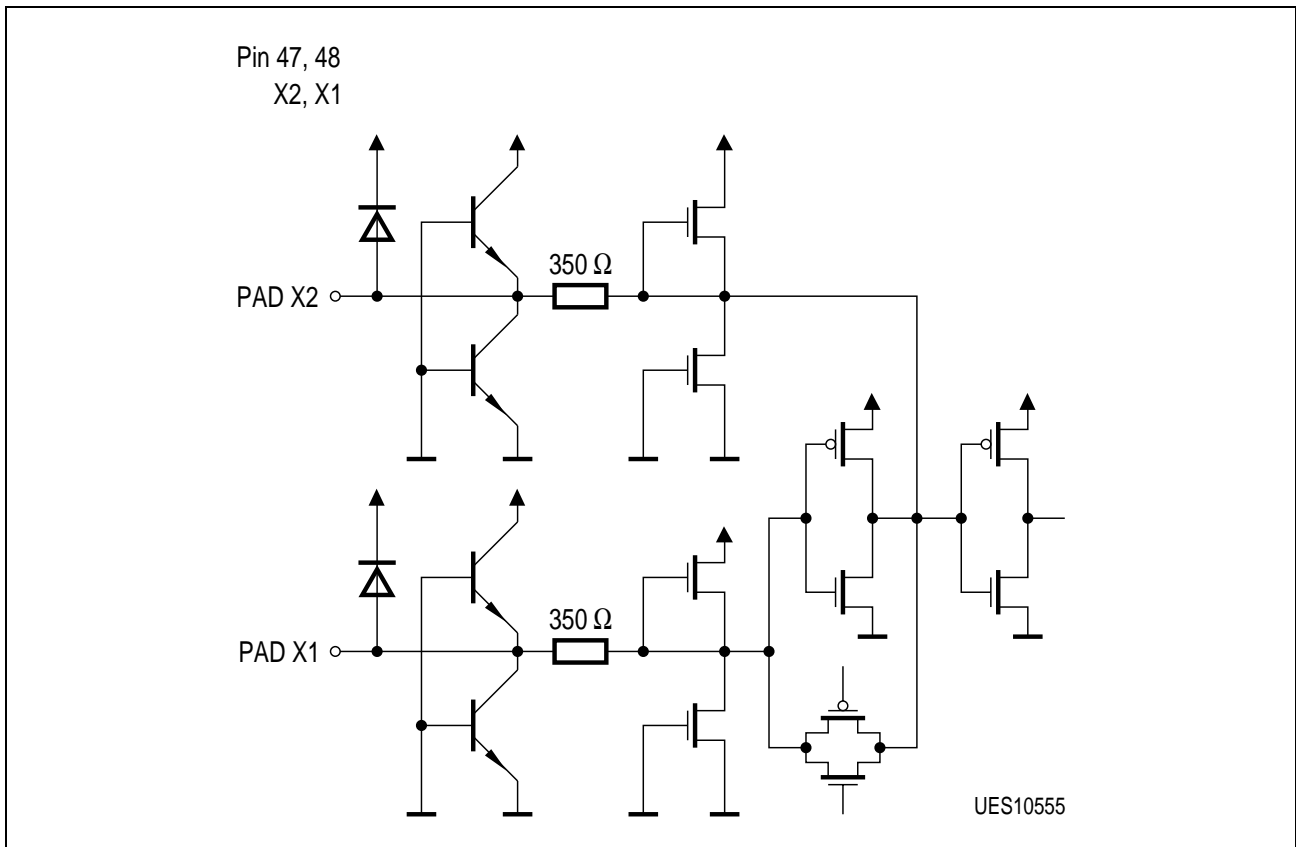

Figure 8

1.6 Block Diagram

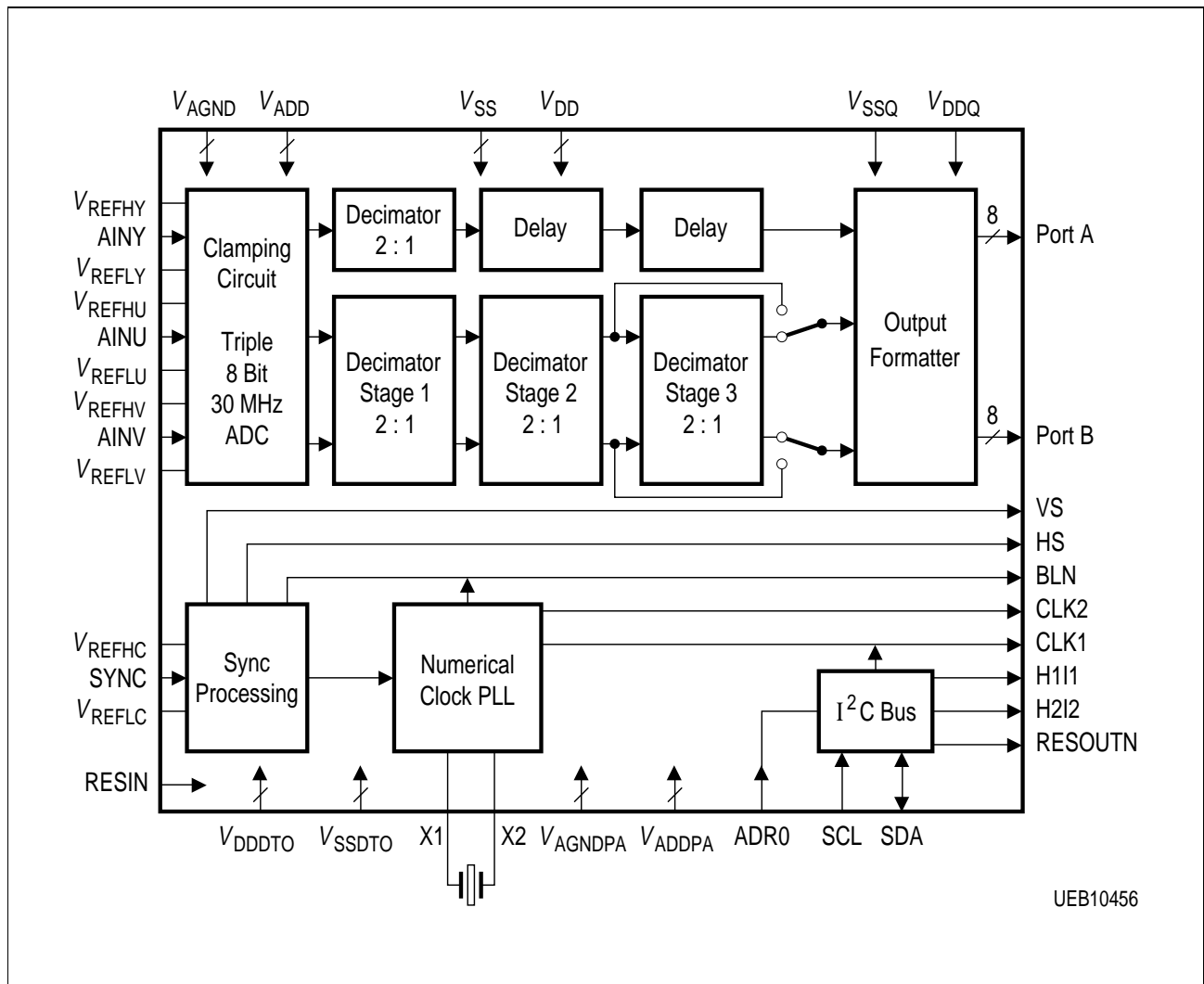

Figure 9

2 System Description

2.1 A/D Converter for YUV Inputs

2.1.1 Introduction

The SDA 9206 implements 3 independent 8-Bit A/D converters. Maximum conversion rate is 30 MHz.

2.1.2 Input Signal Amplification, Prefiltering

The amplification of the input signals can be adjusted via I²C Bus. An internal prefiltering of the analog input signals is implemented. The typ. frequency response of the analog antialiasing prefilter is shown in **figure 10**.

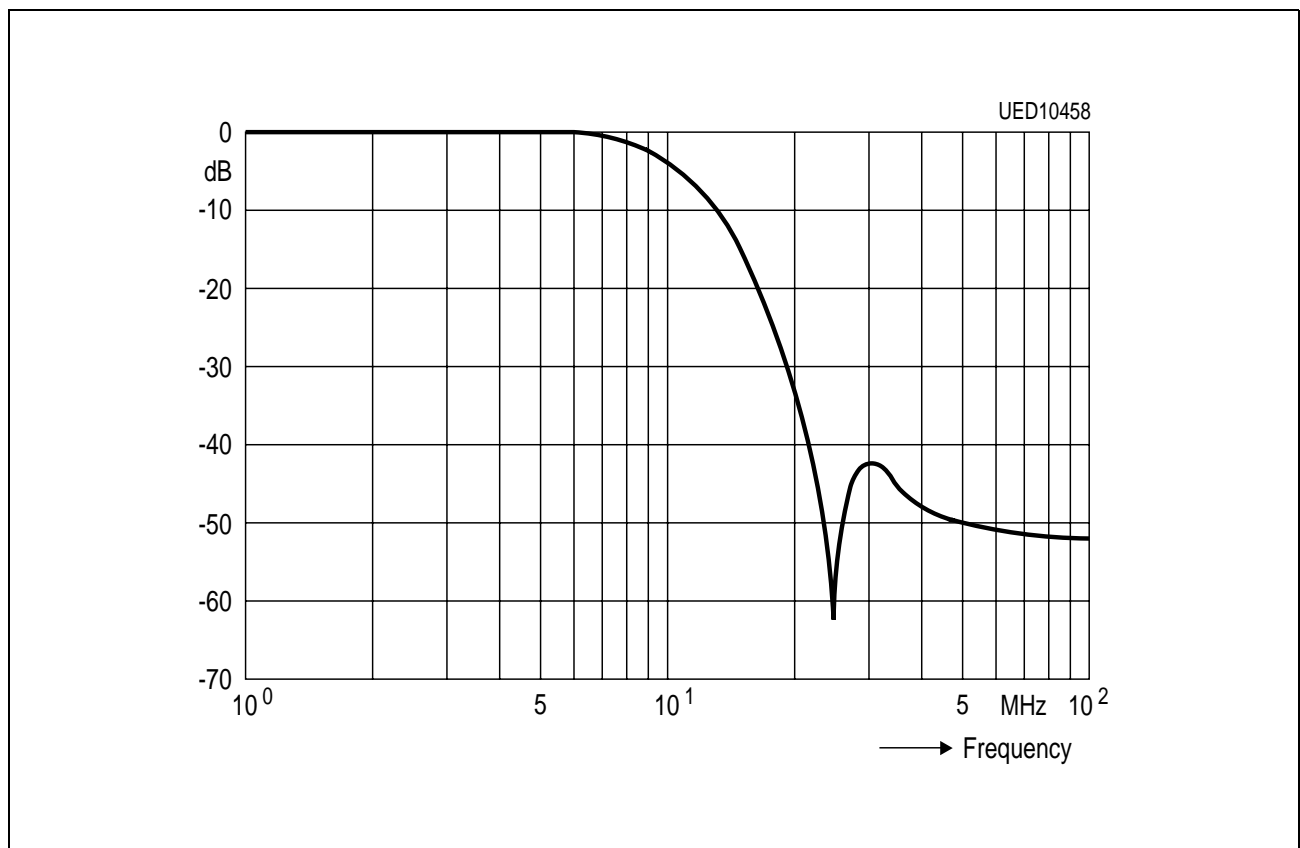

Figure 10
Frequency Response of the Analog Antialiasing Prefilter

2.1.3 Clamping

The analog pins AINY, AINU, AINV are switched simultaneously to on chip generated clamping levels by an on chip clamping pulse H2.

Analog Channel	Straight Binary Code	Two's Complement Code	Components
AINY	0001 0000	1001 0000	Y
AINU, AINV	1000 0000	0000 0000	U, V

The external clamping capacitance is loaded by on chip current sources during clamping. So loading time depends on the values of $C_{ext\ cl}$.

2.1.4 Digital Decimation Filters for YUV

The data rates of digital YUV signals are reduced in decimation filters following the A/D conversion. The overall performance of the decimation filters is tuned to the requirements for TV signals.

In **figure 11** the frequency response of the filter for the Y channel is shown. The input sampling rate is 27 MHz, the output sampling rate is 13.5 MHz.

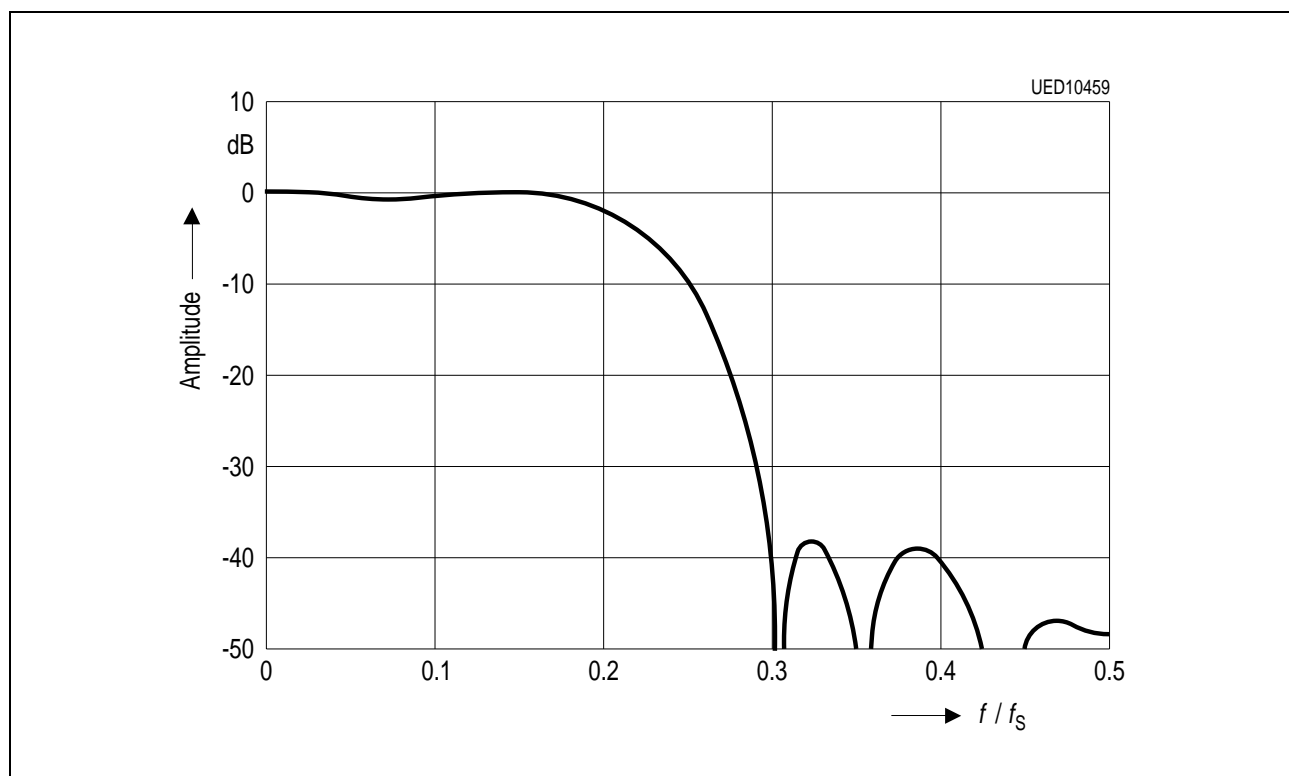

Figure 11
Magnitude Frequency Response of the Luminance Filter
The Input Sampling Frequency f_s is 27 MHz

The total frequency response of the decimator stages 1 and 2 of the UV channels for an input sampling rate of 27 MHz and an output sampling rate of 6.75 MHz is shown in figure 12.

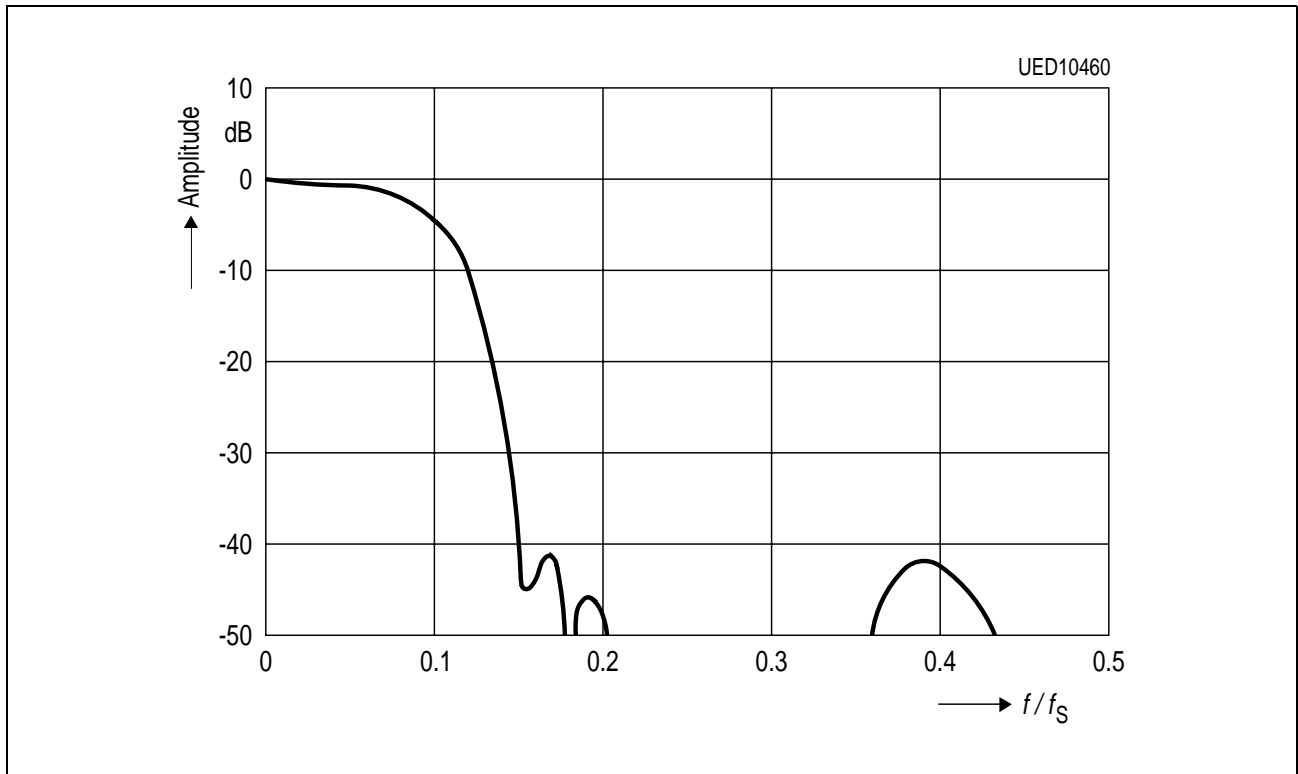

Figure 12
Magnitude Frequency Response for Chroma Signals (Decimator Stages 1 and 2)
The Input Sampling Frequency f_s is 27 MHz

The frequency response of the decimator filter stage 3 of the UV channels for an input sampling rate of 6.75 MHz and an output sampling rate of 3.375 MHz is shown in **figure 13**. The decimator stage 3 is active for 4:1:1 mode and can also be activated for 4:2:2 mode by I²C Bus (control bit UV3FIL).

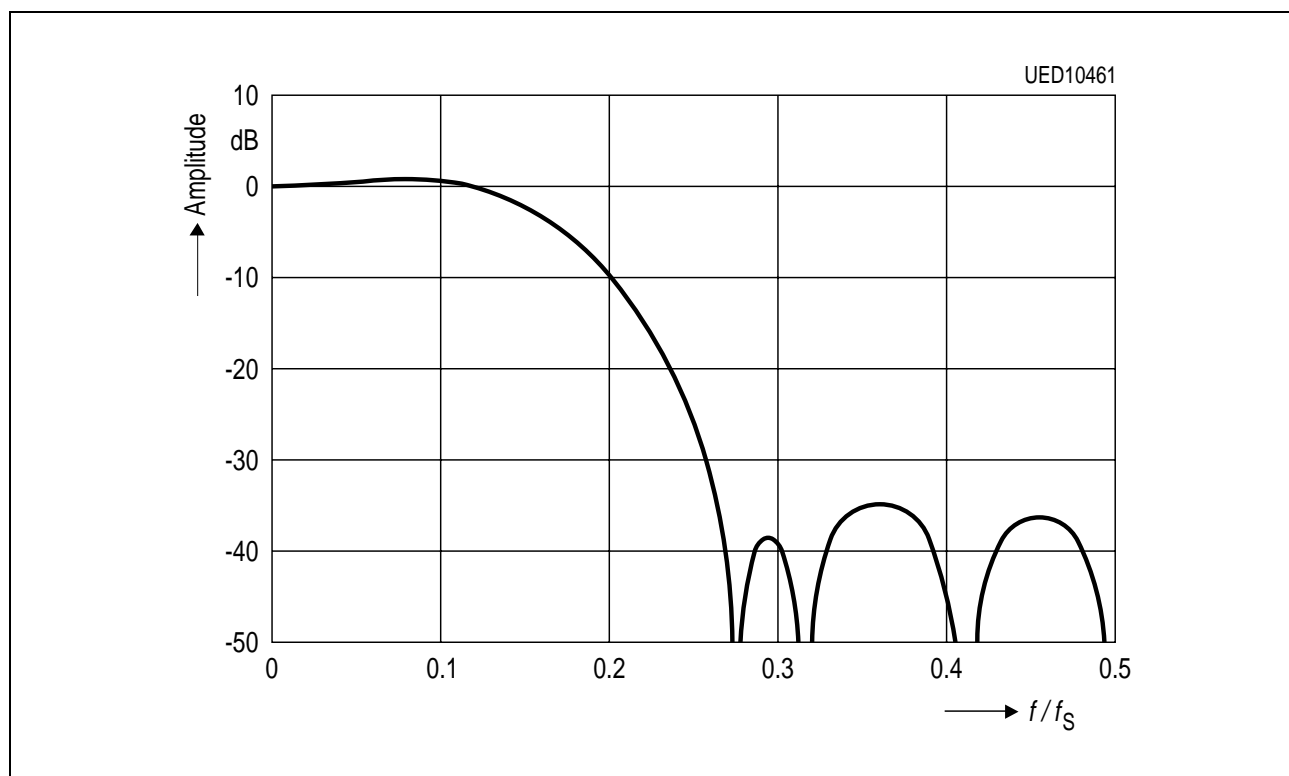

Figure 13
Frequency Response of the Chroma Decimator Stage 3
The Input Sampling Frequency f_s is 6.75 MHz

2.2 Data Output Formatter

Three output data formats can be selected via I²C Bus (control Bits FORMAT). One format corresponds to CCIR 656 (8-Bit bus at a data rate of 27 MHz), an other format makes available Y and UV data separately on 2 parallel 8-Bit buses for Y and UV at a data rate of 13.5 MHz each. The third format is a 12-Bit bus with 8 connections for Y and 4 connections for multiplexed UV data.

Output Pin	Quasiparallel Data FORMAT = 10 or 11 (13.5 MHz)				Parallel Data FORMAT = 01 (13.5 MHz)		CCIR 656 FORMAT = 00 (27 MHz)			
	Y ₀₇	Y ₁₇	Y ₂₇	Y ₃₇	Y ₀₇	Y ₁₇	U ₀₇	Y ₀₇	V ₀₇	Y ₁₇
PAQ7	Y ₀₇	Y ₁₇	Y ₂₇	Y ₃₇	Y ₀₇	Y ₁₇	U ₀₇	Y ₀₇	V ₀₇	Y ₁₇
PAQ6	Y ₀₆	Y ₁₆	Y ₂₆	Y ₃₆	Y ₀₆	Y ₁₆	U ₀₆	Y ₀₆	V ₀₆	Y ₁₆
PAQ5	Y ₀₅	Y ₁₅	Y ₂₅	Y ₃₅	Y ₀₅	Y ₁₅	U ₀₅	Y ₀₅	V ₀₅	Y ₁₅
PAQ4	Y ₀₄	Y ₁₄	Y ₂₄	Y ₃₄	Y ₀₄	Y ₁₄	U ₀₄	Y ₀₄	V ₀₄	Y ₁₄
PAQ3	Y ₀₃	Y ₁₃	Y ₂₃	Y ₃₃	Y ₀₃	Y ₁₃	U ₀₃	Y ₀₃	V ₀₃	Y ₁₃
PAQ2	Y ₀₂	Y ₁₂	Y ₂₂	Y ₃₂	Y ₀₂	Y ₁₂	U ₀₂	Y ₀₂	V ₀₂	Y ₁₂
PAQ1	Y ₀₁	Y ₁₁	Y ₂₁	Y ₃₁	Y ₀₁	Y ₁₁	U ₀₁	Y ₀₁	V ₀₁	Y ₁₁
PAQ0	Y ₀₀	Y ₁₀	Y ₂₀	Y ₃₀	Y ₀₀	Y ₁₀	U ₀₀	Y ₀₀	V ₀₀	Y ₁₀
PBQ7	U ₀₇	U ₀₅	U ₀₃	U ₀₁	U ₀₇	V ₀₇	Z	Z	Z	Z
PBQ6	U ₀₆	U ₀₄	U ₀₂	U ₀₀	U ₀₆	V ₀₆	Z	Z	Z	Z
PBQ5	V ₀₇	V ₀₅	V ₀₃	V ₀₁	U ₀₅	V ₀₅	Z	Z	Z	Z
PBQ4	V ₀₆	V ₀₄	V ₀₂	V ₀₀	U ₀₄	V ₀₄	Z	Z	Z	Z
PBQ3	Z	Z	Z	Z	U ₀₃	V ₀₃	Z	Z	Z	Z
PBQ2	Z	Z	Z	Z	U ₀₂	V ₀₂	Z	Z	Z	Z
PBQ1	Z	Z	Z	Z	U ₀₁	V ₀₁	Z	Z	Z	Z
PBQ0	Z	Z	Z	Z	U ₀₀	V ₀₀	Z	Z	Z	Z

X_{AB}: X: signal component A: sample number B: bit number
 Z: Pin is in tristate mode.

The BLN signal marks the active part of the video line (see figure 14).

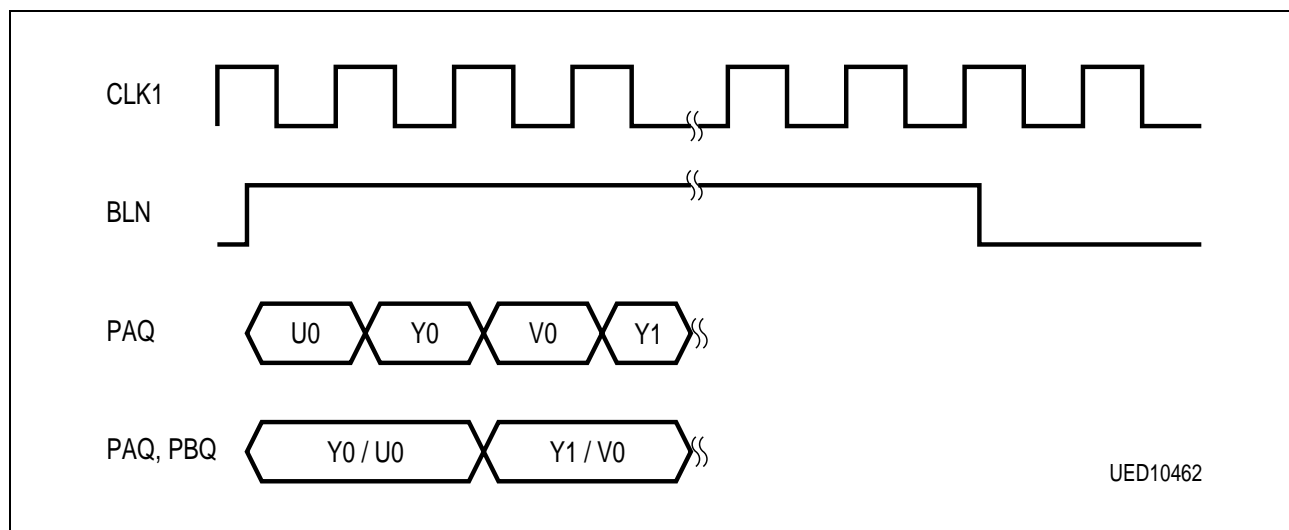

Figure 14

2.2.1 Output Coding for Straight Binary / Two's Complement Mode

Straight binary or Two's complement output coding is selectable for each separate signal component (Y and UV) via I²C-Bus control bits YCODE and UVCODE.

For straight binary coding a special suppression of code 0 and code 255 is provided in output format mode according CCIR 656.

Table 1
Output Coding

Step	AINY	AINU, AINV	OFL Bit	UFL Bit	Straight Binary		Two's Complement	
					7654	3210	7654	3210
Underflow	$< V_{CY} - 0.125 V$	$< V_{CU, v} - 1.0 V$	0	1	0000	0000	1000	0000
0	$V_{CY} - 0.125 V$	$V_{CU, v} - 1.0 V$	0	0	0000	0000	1000	0000
1	$V_{CY} - 0.117 V$	$V_{CU, v} - 0.992 V$	0	0	0000	0001	1000	0001
2	$V_{CY} - 0.109 V$	$V_{CU, v} - 0.984 V$	0	0	0000	0010	1000	0010
•	•	•	•	•	•		•	
•	•	•	•	•	•		•	
253	$V_{CY} + 1.859 V$	$V_{CU, v} + 0.984 V$	0	0	1111	1101	0111	1101
254	$V_{CY} + 1.867 V$	$V_{CU, v} + 0.992 V$	0	0	1111	1110	0111	1110
255	$V_{CY} + 1.875 V$	$V_{CU, v} + 1.0 V$	0	0	1111	1111	0111	1111
Overflow	$> V_{CY} + 1.875 V$	$> V_{CU, v} + 1.0 V$	1	0	1111	1111	0111	1111

V_{CY} , $V_{CU, v}$: ext. clamping level during clamping at $C_{ext cl}$ on channel AINY resp. AINU, AINV

Table 1 is valid for $V_{REFL} = 2.2 V$ and $V_{REFH} = 4.2 V$, xAMP = 0000

Table 2
Output Coding in Case of CCIR 656 Format, FORMAT = 00

Step	AINY	AINU, AINV	OFL Bit	UFL Bit	Straight Binary		Two's Complement	
					7654	3210	7654	3210
Underflow	$< V_{CY} - 0.125 \text{ V}$	$< V_{CU,V} - 1.0 \text{ V}$	0	1	0000	0001	1000	0000
0	$V_{CY} - 0.125 \text{ V}$	$V_{CU,V} - 1.0 \text{ V}$	0	0	0000	0001	1000	0000
1	$V_{CY} - 0.117 \text{ V}$	$V_{CU,V} - 0.992 \text{ V}$	0	0	0000	0001	1000	0001
2	$V_{CY} - 0.109 \text{ V}$	$V_{CU,V} - 0.984 \text{ V}$	0	0	0000	0010	1000	0010
•	•	•	•	•	•		•	
•	•	•	•	•	•		•	
253	$V_{CY} + 1.859 \text{ V}$	$V_{CU,V} + 0.984 \text{ V}$	0	0	1111	1101	0111	1101
254	$V_{CY} + 1.867 \text{ V}$	$V_{CU,V} + 0.992 \text{ V}$	0	0	1111	1110	0111	1110
255	$V_{CY} + 1.875 \text{ V}$	$V_{CU,V} + 1.0 \text{ V}$	0	0	1111	1110	0111	1111
Overflow	$> V_{CY} + 1.875 \text{ V}$	$> V_{CU,V} + 1.0 \text{ V}$	1	0	1111	1110	0111	1111

V_{CY} , $V_{CU,V}$: ext. clamping level during clamping at $C_{ext\ cl}$ on channel AINY resp. AINU, AINV

Table 2 is valid for $V_{REFL} = 2.2 \text{ V}$ and $V_{REFH} = 4.2 \text{ V}$, xAMP = 0000

2.3 Clock Sync Generation

The clock sync generator is a phase locked loop that locks on a horizontal SYNC input signal and generates the clock signals as well as additional control output signals.

2.3.1 Horizontal PLL (HPLL)

The input signal SYNC may be either a CVBS signal or a composite sync signal. The polarity of the SYNC signal can be both positive or negative (I²C-Bit SYPOL). The edges of the SYNC input pulses should not be steeper than 100 ns. The frequency of the SYNC signal can be of normal or double line frequency (I²C-Bit 2FH).

The SYNC is clamped before A/D conversion. For DC-input signals clamping can be disabled (I²C-Bit CLOF). A/D conversion takes place with 7 bits and a nominal frequency of 27 MHz.

The digital HPLL filters the signal with a cutoff frequency of 1 MHz (2 MHz for 2fh mode). If 1fh mode is used the sampling frequency is decimated to 13.5 MHz. Following the low pass filtering a black- and sync bottom- level measurement takes place in order to calculate a threshold value. By means of this value the phase difference between the HPLL output and the SYNC input pulse is determined. Using a digital PI filter an increment is calculated from this for the Discrete Timing Oscillator (DTO). It is possible

to adapt the nominal frequency of the DTO by means of 5 I²C-Bus bits (INC4...INC0) such shifting the center frequency according to the momentary standard used.

For the different applications the following values of INC are allowed (values valid for a crystal frequency of 24.576 MHz):

Application	FH [Hz]	2FH	YUV-ADCs	INC
PAL	15625	0	active	6
NTSC	15750	0	active	6
PAL (100 Hz/VGA)	31250	1	inactive	6
NTSC (120 Hz/VGA)	31500	1	inactive	6
ATV	32400	1	inactive	8
MUSE	33750	1	inactive	11
Macintosh	35000	1	inactive	14
VGA	38000	1	inactive	21

Note: A change of INC causes spontaneous changes of the generated clock frequencies!

The DTO generates a saw-tooth with a frequency that is proportional to the increment. The saw-tooth is converted into a sinusoidal clock signal by means of a D/A converter and applied to an analog PLL which multiplies the frequency and minimizes residual jitter.

By means of the I²C bits S1CL and S2CL the output frequency on pins CLK1 and CLK2 can be set. In this manner a clock is provided that is line-locked with the SYNC-input signal. The ratio of these clock frequencies to the horizontal frequency of SYNC depends only on the I²C-Bus bits S1CL, S2CL, HPLL and 2FH.

For the different modes the following values of S1CL and S2CL are allowed:

Mode	YUV-ADC	2FH	S1CL	S2CL	f_{CLK1} (MHz)	f_{CLK2} (MHz)
CCIR	enabled	0	11	11	27	27
CCIR	enabled	0	11	00	27	tristate
4:2:2, 4:1:1	enabled	0	11	11	27	27
4:2:2, 4:1:1	enabled	0	10	00	13.5	tristate
VGA	disabled	1	01	11	6.25 ... 8.75	25 ... 35
VGA	disabled	1	10	11	12.5 ... 17.5	25 ... 35

The digital horizontal PLL supplies a noise-suppressed horizontal pulse.

During 1fh mode (2FH = 0) the digital HPLL also supplies a noise-suppressed vertical pulse obtained by digital integration of the main equalizing pulses. An integration time of 26.6 μ s or 11.3 μ s can be set by the I²C Bus. This functionality is switched off during 2fh mode (2FH = 1).

2.3.2 Vertical Sync Processing (only available for 1fh mode)

Vertical sync processing consists of:

- 625/525 line detection
- vertical noise suppression

The vertical pulses are obtained from the SYNC signal by integration. The 625/525 line detector measures the number of lines per field. By taking the average of the individual measurements with two up/down counters, the status bits 'FF' and 'FFGF' are obtained.

When vertical noise suppression is switched on (VOFF = 0), the vertical pulse obtained from the SYNC signal by integration is admitted only within a preset window (refer to timing diagram) and appears as a VS pulse. The width of the window can be set via the I²C Bus.

In the temporary absence of vertical pulses in SYNC, a continuous VS can be generated by switching on a 'flywheel mode' (SCHW = 1) providing a number of lines per field of 312.5 or 262.5 respectively.

When interference to SYNC is heavy, missing vertical pulses can be supplemented by switching on the flywheel mode and vertical interference can be eliminated by switching on the noise suppression circuitry. Noise suppression and the flywheel mode can be enabled independently of each other.

There is also the possibility of generating VS in the free-running mode. The VS pulses are then completely independent of the vertical sync pulse in SYNC. When FREE = 1 and SCHW = 1, a VS pulse is generated every 262.5 or 312.5 lines (VF = 1 or 0 respectively). When FREE = 1 and SCHW = 0, a VS pulse is generated every 279 or 339 lines (VF = 1 or 0 respectively). Free-running generation of VS occurs every 262 or 312 in the terminal mode (TERM = 1).

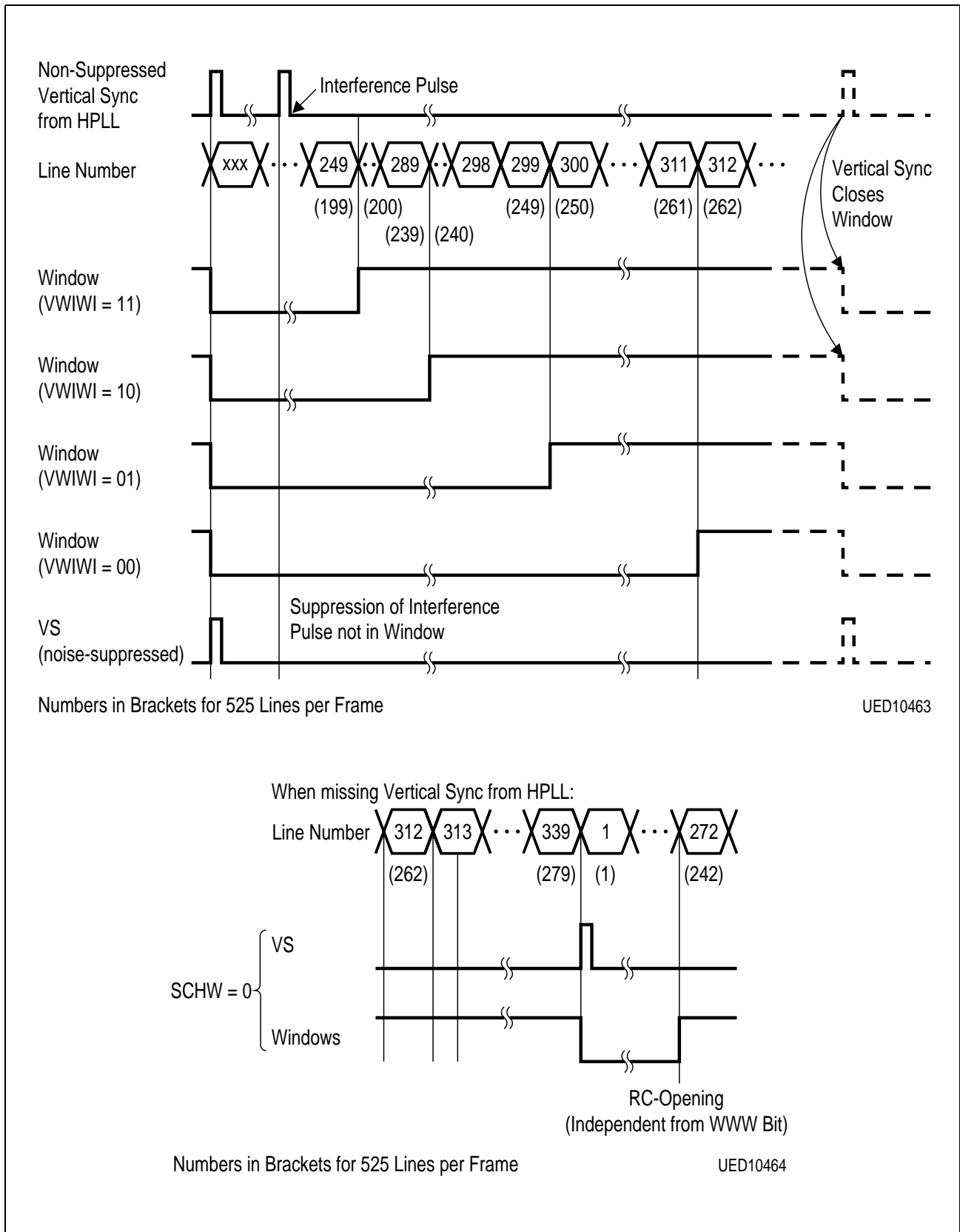

Figure 15
Window for Vertical Pulse Noise Suppression

2.3.3 Pulse Generation

The clock sync generator supplies the following pulses:

- HS
- VS
- BLN
- Two clamping pulses H1 and H2. H2 is also the internal clamping pulse of the YUV-ADCs.
- The HS pulse is 16 13.5 MHz clock periods long and can be shifted by the I²C-Bus in increments of four 13.5 MHz clock periods.
- For the VS pulse refer to vertical noise suppression.
- With the BLN pulse the start time (high-to-low edge) and the stop time (low-to-high edge) can be set within a certain range of lines in increments of 13.5 MHz clock periods by I²C Bus. The timing of BLN does not change during the field blanking interval.
- During the BLN pulse the Y-U-V output data are set to their clamping level.
- For pulse H1 the start time (low-to-high edge) and stop time can be set in increments of two 13.5 MHz clock periods.
- For pulse H2 the start time (low-to-high edge) and stop time can be set in increments of 13.5 MHz clock periods.

The timing of the BLN, H1, H2, VS and HS pulses can be set by the customer using the specified I²C-Bus bits. **Figure 9** shows the ranges of those settings.

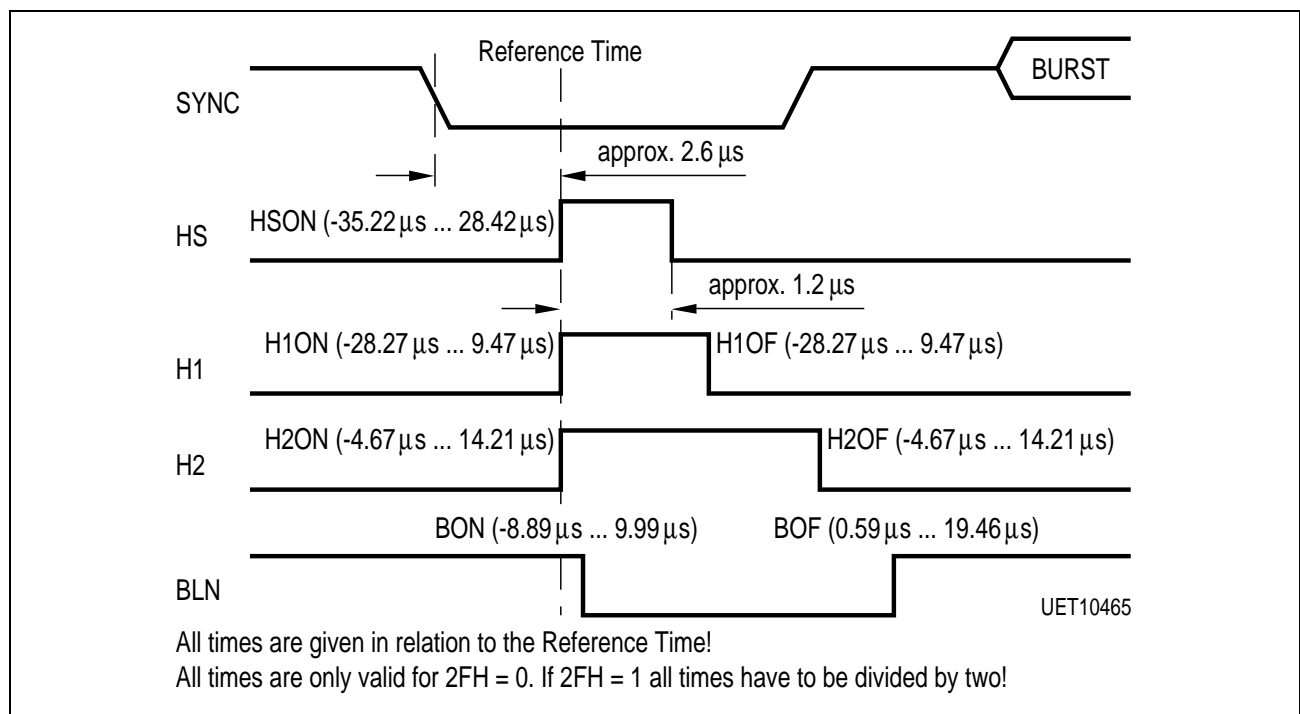

Figure 16
I²C-Bus Programming Areas of Horizontal-Frequency Pulses

2.3.4 Miscellaneous Circuit Sections

To suppress bottom flutter in VCR mode, the frequency of the clock can be 'hold' by 'freezing' the increment of the HPLL. The vertical-frequency 'freezing-time' starts a number of lines (programmable by the I²C Bus) before the vertical pulse and then lasts for a number (programmable) of lines. The settings do not depend on I²C-Bit TV. This functionality is only available for the 1fh mode (2FH = 0).

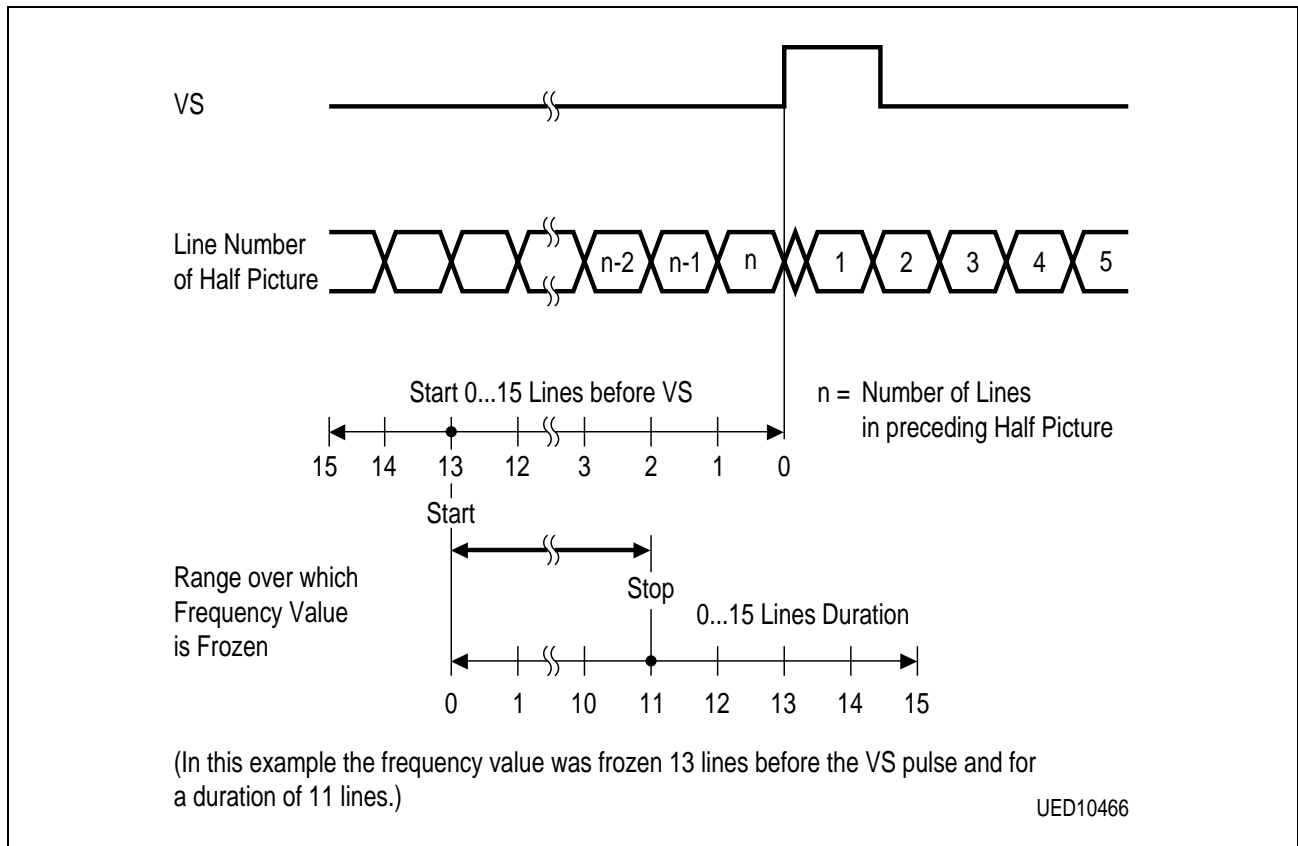

Figure 17
I²C-Bus Programming Area which Clock Frequency Value Generated by HPLL can be Frozen

An active low reset signal for other chips is available at pin RESOUTN. It is activated when the chip supply voltage V_{DD} is switched on or when voltage glitches occur on it. RESOUTN also is activated by pin RESIN. The RESOUTN pulse signal is not cancelled until the crystal oscillator resonates and in addition stretched by an internal circuit for approximately 127 lines (8 ms).

2.4 I²C Bus

2.4.1 I²C-Bus Address

1	0	1	1	0	0	B
---	---	---	---	---	---	---

B: equal to the value set on pin ADR0

2.4.2 I²C-Bus Format

Write:

S	1	0	1	1	0	0	B	0	A	Subaddress	A	Data Byte	A	*****	A	P
---	---	---	---	---	---	---	---	---	---	------------	---	-----------	---	-------	---	---

Read:

S	1	0	1	1	0	0	B	1	A	...	Status Byte 0	A	Status Byte 1	A	Data*****	
										**** Byte n	A	Data Byte (n+1)	A	*****	NA	P

Reading starts with status byte 0, followed by status byte 1 and then in succession by data byte n, data byte n+1..., where n is the last write address. Specification of a subaddress in reading mode is not possible.

- S: Start condition
- A: Acknowledge
- P: Stop condition
- NA: Not Acknowledge

An automatic address increment function is implemented.

After switching on the IC or RESIN = 0, all bits are set to defined states. Particularly:

Register	Default value	Register	Default value
00 _H	10 _H	0C _H	00 _H
01 _H	40 _H	0D _H	00 _H
02 _H	00 _H	0E _H	00 _H
03 _H	00 _H	0F _H	00 _H
04 _H	28 _H	10 _H	00 _H
05 _H	00 _H	11 _H	00 _H
06 _H	00 _H	12 _H	00 _H
07 _H	06 _H	13 _H	00 _H
08 _H	00 _H	14 _H	13 _H
09 _H	00 _H	15 _H	00 _H
0A _H	00 _H	16 _H	00 _H
0B _H	00 _H	17 _H	00 _H

2.4.3 I²C-Bus Commands

Subadd.	Data Byte							
	D7	D6	D5	D4	D3	D2	D1	D0
00 _H	0	UV3FIL	FORMAT1	FORMAT0	UVCODE	YCODE	OENB	OENA
01 _H	YD3	YD2	YD1	YD0	0	0	0	0
02 _H	I2	I1	SELH2I2	SELH1I1	0	0	0	0
03 _H	0	0	0	0	CGSUP1	CGSUP0	VWIWI1	VWIWI0
04 _H	0	OEFB	S1CL1	S1CL0	S2CL1	S2CL0	0	0
05 _H	0	SCHW	HPLL	VTHRE	CLOF	0	0	0
06 _H	TV	FREE	VOFF	VF	TERM	GENMOD	0	SYPOL
07 _H	2FH	HSWMA	HSWMIN	INC4	INC3	INC2	INC1	INC0
08 _H	BON7	BON6	BON5	BON4	BON3	BON2	BON1	BON0
09 _H	BOF7	BOF6	BOF5	BOF4	BOF3	BOF2	BOF1	BOF0
0A _H	H1ON7	H1ON6	H1ON5	H1ON4	H1ON3	H1ON2	H1ON1	H1ON0
0B _H	H1OF7	H1OF6	H1OF5	H1OF4	H1OF3	H1OF2	H1OF1	H1OF0
0C _H	H2ON7	H2ON6	H2ON5	H2ON4	H2ON3	H2ON2	H2ON1	H2ON0
0D _H	H2OF7	H2OF6	H2OF5	H2OF4	H2OF3	H2OF2	H2OF1	H2OF0
0E _H	HSO7	HSO6	HSO5	HSO4	HSO3	HSO2	HSO1	HSO0
0F _H	0	0	0	0	0	0	0	0
10 _H	FION3	FION2	FION1	FION0	FILE3	FILE2	FILE1	FILE0
11 _H	SYNAMP3	SYNAMP2	SYNAMP1	SYNAMP0	YAMP3	YAMP2	YAMP1	YAMP0
12 _H	UAMP3	UAMP2	UAMP1	UAMP0	VAMP3	VAMP2	VAMP1	VAMP0
13 _H	DATDEL2	DATDEL1	DATDEL0	DATSLOP	CLKSLOP1	CLKSLOP0	0	0
14 _H	0	0	0	1	0	0	1	1
15 _H	0	0	0	0	0	0	0	0
16 _H	0	0	0	0	0	0	0	0
17 _H	0	0	0	0	0	0	0	0

2.4.4 Detailed Description

Subaddress 00_H

Bit	Name	Function
D7	<u>0</u>	Reserved
D6	UV3FIL	Filter stage 3 for UV data (FORMAT = 0X) <u>0</u> : OFF 1: ON Note: For FORMAT = 1X filter stage 3 for UV data is "on" (UV3FIL = don't care)
D5...D4	FORMAT	Selection of output data interface: 00: Output data format according CCIR 656 (8 wires at Port A) <u>01</u> : Parallel output data format (2 x 8 wires) 10: Quasiparallel 12 wire interface 11: Quasiparallel 12 wire interface
D3	UVCODE	Coding of UV data: <u>0</u> : Straight binary code 1: Two's complement code
D2	YCODE	Coding of Y data: <u>0</u> : Straight binary code 1: Two's complement code
D1	OENB	Output enable port B: <u>0</u> : Tristate 1: Port enabled
D0	OENA	Output enable port A: <u>0</u> : Tristate 1: Port enabled

Subaddress 01_H

Bit	Name	Function
D7...D4	YD	Delay compensation in Y-signal path (13.5 MHz clocks): 0000: ... - 0.30 μs 0001 0010 0011 0100: ... 0 μs : 1110 1111: ... 0.81 μs
D3...D0	0000	Reserved

Subaddress 02_H

Bit	Name	Function
D7	I2	Voltage level of H2I2 output (SELH2I2 = 1): 0: <u>Low voltage at pin H2I2</u> 1: High voltage at pin H2I2
D6	I1	Voltage level of H1I1 output (SELH1I1 = 1): 0: <u>Low voltage at pin H1I1</u> 1: High voltage at pin H1I1
D5	SELH2I2	Function of pin H2I2: 0: <u>H2 (line frequency, start and stop programmable)</u> 1: I2 (low/high programmable)
D4	SELH1I1	Function of pin H1I1: 0: <u>H1 (line frequency, start and stop programmable)</u> 1: I1 (low/high programmable)
D3	0	Reserved
D2	0	Reserved
D1	0	Reserved
D0	0	Reserved

Subaddress 03_H

Bit	Name	Function
D7...D4	<u>0000</u>	Reserved
D3...D2	CGSUP	Suppression of black level disturbances caused by copy guarded tapes <u>00: No function</u> 01: Black level error is limited to + / - 32 (~ 27 mV) 10: Black level error is limited to + / - 16 (~ 14 mV) 11: Black level error is limited to + / - 8 (~ 7 mV)
D1...D0	VWIWI	Width of Window in Vertical Processing: <u>00: Narrow window: open from line 312 for PAL and 262 for NTSC</u> 01: Window: open from line 300 for PAL and 250 for NTSC 10: Window: open from line 290 for PAL and 240 for NTSC 11: Very wide window: open from line 250 for PAL and 200 for NTSC

Subaddress 04_H

Bit	Name	Function
D7	<u>0</u>	Reserved
D6	OEFB	Output enable for Featurebox signals BLN, HS and VS: <u>0: BLN, HS, VS outputs tristate</u> 1: BLN, HS, VS outputs enabled (2FH = 0) BLN, HS outputs enabled, VS output tristate (2FH = 1)
D5...D4	S1CL	Selection of clock frequency on pin CLK1: 00: Tristate 01: 6.75 MHz <u>10: 13.5 MHz</u> 11: 27 MHz For the allowed values of S1CL refer to table chapter 2.3.1!
D3...D2	S2CL	Selection of clock frequency on pin CLK2: 00: Tristate 01: 6.75 MHz <u>10: 13.5 MHz</u> 11: 27 MHz For the allowed values of S2CL refer to table chapter 2.3.1!
D1...D0	<u>00</u>	Reserved

Subaddress 05_H

Bit	Name	Function
D7	<u>0</u>	Reserved
D6	SCHW	Mode of vertical pulse generation: 0: <u>No flywheel mode</u> 1: Flywheel mode
D5	HPLL	Relationship between horizontal frequency in SYNC and default frequency on CLK1 and CLK2: 0: <u>864</u> 1: 858
D4	VTHRE	Minimum sync pulse length from which a vertical pulse is detected: 0: <u>26.6 μs</u> 1: 11.3 μs
D3	CLOF	Clamping of SYNC for clock generator: 0: <u>Clamping on</u> 1: Clamping off
D2...D0	<u>000</u>	Reserved

Subaddress 06_H

Bit	Name	Function																																			
D7	TV	Selection of HPLL lock-in behavior: 0: <u>Optimum for VCR</u> 1: Optimum for SYNC from network																																			
D6	FREE	Generation of V pulse: 0: <u>V derived from SYNC</u> 1: Free-running generation; vertical frequency is determined by VF bit, VOFF bit is enabled, SCHW bit should be set to 1																																			
D5	VOFF	Vertical noise suppression: 0: <u>Noise suppression enabled</u> 1: No noise suppression																																			
D4	VF	Number of lines per field: 0: <u>312.5 or 312</u> 1: 262.5 or 262 <i>Note: VF must be set to the number of lines present in SYNC for fly-wheel and noise suppression modes. VF determines the number of lines per field for the free-running or terminal mode.</i>																																			
D3	TERM	Terminal mode: <table border="1"> <thead> <tr> <th>FREE</th> <th>TERM</th> <th>SCHW</th> <th>VF</th> <th>Number of Lines per Field generated in Free-Running Mode</th> </tr> </thead> <tbody> <tr> <td>don't care</td> <td>1</td> <td>don't care</td> <td>0</td> <td>312</td> </tr> <tr> <td>don't care</td> <td>1</td> <td>don't care</td> <td>1</td> <td>262</td> </tr> <tr> <td>1</td> <td><u>0</u></td> <td>1</td> <td>0</td> <td>312.5</td> </tr> <tr> <td>1</td> <td><u>0</u></td> <td>1</td> <td>1</td> <td>262.5</td> </tr> <tr> <td>1</td> <td><u>0</u></td> <td>0</td> <td>0</td> <td>339</td> </tr> <tr> <td>1</td> <td><u>0</u></td> <td>0</td> <td>1</td> <td>279</td> </tr> </tbody> </table>	FREE	TERM	SCHW	VF	Number of Lines per Field generated in Free-Running Mode	don't care	1	don't care	0	312	don't care	1	don't care	1	262	1	<u>0</u>	1	0	312.5	1	<u>0</u>	1	1	262.5	1	<u>0</u>	0	0	339	1	<u>0</u>	0	1	279
FREE	TERM	SCHW	VF	Number of Lines per Field generated in Free-Running Mode																																	
don't care	1	don't care	0	312																																	
don't care	1	don't care	1	262																																	
1	<u>0</u>	1	0	312.5																																	
1	<u>0</u>	1	1	262.5																																	
1	<u>0</u>	0	0	339																																	
1	<u>0</u>	0	1	279																																	
D2	GENMOD	Clock generator mode 0: <u>Normal PLL mode</u> 1: Generator mode (fixed frequency output, controlled by INC)																																			
D1	<u>0</u>	Reserved																																			
D0	SYPOL	SYNC polarity: 0: <u>Negative sync signals</u> (normal SYNC input) 1: Positive sync signals																																			

Subaddress 07_H

Bit	Name	Function
D7	2FH	Selection of input frequency range: 0: <u>Normal line frequencies (around 15.6 kHz)</u> 1: Double line frequencies (31.2...38 kHz) [YUV A/D converters are switched off]
D6	HSWMA	Maximum width of HSYNC (input SYNC): 0: <u>6.2 μs for low FH-range</u> 3.1 μs for high FH-range (2FH = 1) 1: 9.0 μs for low FH-range 4.5 μs for high FH-range (2FH = 1)
D5	HSWMI	Minimum width of HSYNC (input SYNC): 0: <u>3.0 μs for low FH-range</u> 1.5 μs for high FH-range (2FH = 1) 1: 1.7 μs for low FH-range 0.8 μs for high FH-range (2FH = 1)
D4...D0	INC	Nominal PLL output frequency: INC = <u>00110</u> For the allowed values of INC refer to table chapter 2.3.1! Calculation of INC for low FH range: $INC = INT\left(\frac{f_h}{f_q} * 110592 - 64,625\right)$ for high FH range (2FH = 1): $INC = INT\left(\frac{f_h}{f_q} * 55292 - 64,625\right)$

Subaddress 08_H

Bit	Name	Function
D7...D0	BON	BLN start time in relation reference time (refer to the following table and to timing diagram)

BON7...BON0	Number	13.5 MHz Cycles	Time (2FH = 0)
1000 0000	- (- 128) + 7	= 135	9.99 μs
...
1111 1111	- (- 1) + 7	= 8	0.60 μs
<u>0000 0000</u>	<u>- (0) + 7</u>	<u>= 7</u>	<u>0.52 μs</u>
0000 0001	- (+ 1) + 7	= 6	0.44 μs
...
0111 1111	- (+ 127) + 7	= - 120	- 8.89 μs

Subaddress 09_H

Bit	Name	Function
D7...D0	BOF	BLN stop time in relation to reference time: (refer to the following table and to timing diagram)

BOF7...BOF0	Number	13.5 MHz Cycles	Time (2FH = 0)
<u>0000 0000</u>	<u>(0) + 8</u>	<u>= 8</u>	<u>0.59 μs</u>
0000 0001	(+ 1) + 8	= 9	0.67 μs
...
0111 1111	(+ 127) + 8	= 135	9.99 μs
1000 0000	(+ 128) + 8	= 136	10.06 μs
1000 0001	(+ 129) + 8	= 137	10.14 μs
...
1111 1110	(+ 254) + 8	= 262	19.39 μs
1111 1111	(+ 255) + 8	= 263	19.46 μs

Subaddress 0A_H

Bit	Name	Function
D7...D0	H1ON	H1 start time in relation to reference time: (refer to the following table and to timing diagram)

H1ON7...H1ON0	Number	13.5 MHz Cycles	Time (2FH = 0)
1100 0000	- (- 64) x 2	= 128	9.47 μs
...
1111 1111	- (- 1) x 2	= 2	0.15 μs
<u>0000 0000</u>	<u>- (0) x 2</u>	<u>= 0</u>	<u>0 μs</u>
0000 0001	- (+ 1) x 2	= - 2	- 0.15 μs
...
0111 1111	- (+ 127) x 2	= - 254	- 18.79 μs
1000 0000	- (+ 128) x 2	= - 256	- 18.94 μs
1000 0001	- (+ 129) x 2	= - 258	- 19.09 μs
...
1011 1111	- (+ 191) x 2	= - 382	- 28.27 μs

Subaddress 0B_H

Bit	Name	Function
D7...D0	H1OF	H1 stop time in relation to reference time: (refer to the following table and to timing diagram)

H1OF7...H1OF0	Number	13.5 MHz Cycles	Time (2FH = 0)
1100 0000	- (- 64) x 2	= 128	9.47 μs
...
1111 1111	- (- 1) x 2	= 2	0.15 μs
<u>0000 0000</u>	<u>- (0) x 2</u>	<u>= 0</u>	<u>0 μs</u>
0000 0001	- (+ 1) x 2	= - 2	- 0.15 μs
...
0111 1111	- (+ 127) x 2	= - 254	- 18.79 μs
1000 0000	- (+ 128) x 2	= - 256	- 18.94 μs
1000 0001	- (+ 129) x 2	= - 258	- 19.09 μs
...
1011 1111	- (+ 191) x 2	= - 382	- 28.27 μs

Subaddress 0C_H

Bit	Name	Function
D7...D0	H2ON	H2 start time in relation to reference time: (H2 is always used as clamping reference for the YUV ADCs) (refer to the following table and to timing diagram)

H2ON7...H2ON0	Number	13.5 MHz Cycles	Time (2FH = 0)
0100 0000	- (- 192)	= 192	14.21 μs
...
0111 1111	- (- 129)	= 129	9.55 μs
1000 0000	- (- 128)	= 128	9.47 μs
1000 0001	- (- 127)	= 127	9.40 μs
...
1111 1111	- (- 1)	= 1	0.07 μs
<u>0000 0000</u>	<u>- (0)</u>	<u>= 0</u>	<u>0 μs</u>
0000 0001	- (+ 1)	= - 1	- 0.07 μs
...
0011 1111	- (+ 63)	= - 63	- 4.67 μs

Subaddress 0D_H

Bit	Name	Function
D7...D0	H2OF	H2 stop time in relation to reference time: (H2 is always used as clamping reference for the YUV ADCs) (refer to the following table and to timing diagram)

H2OF7...H2OF0	Number	13.5 MHz Cycles	Time (2FH = 0)
0100 0000	- (- 192)	= 192	14.21 μs
...
0111 1111	- (- 129)	= 129	9.55 μs
1000 0000	- (- 128)	= 128	9.47 μs
1000 0001	- (- 127)	= 127	9.40 μs
...
1111 1111	- (- 1)	= 1	0.07 μs
<u>0000 0000</u>	<u>- (0)</u>	<u>≡ 0</u>	<u>0 μs</u>
0000 0001	- (+ 1)	= - 1	- 0.07 μs
...
0011 1111	- (+ 63)	= - 63	- 4.67 μs

Subaddress 0E_H

Bit	Name	Function
D7...D0	HS0N	HS start time in relation to reference time: (refer to the following table and to timing diagram)

HS0N7...HS0N0	Number	13.5 MHz Cycles	Time (2FH = 0)
1010 0000	- (- 96) x 4	= 384	28.42 μs
...
1111 1111	- (- 1) x 4	= 4	0.30 μs
<u>0000 0000</u>	<u>- (0) x 4</u>	<u>≡ 0</u>	<u>0 μs</u>
0000 0001	- (+ 1) x 4	= - 4	- 0.30 μs
...
0111 0110	- (+ 118) x 4	= - 472	- 34.93 μs
0111 0111	- (+ 119) x 4	= - 476	- 35.22 μs

Subaddress 0F_H

Bit	Name	Function
D7...D0	0000 0000	Reserved

Subaddress 10_H

Bit	Name	Function
D7...D4	FION	Start of clock frequency freezing in number of lines before the vertical pulse (only valid for 2FH = 0): 0000: 0 (no freezing) 0001: 1 : : 1111: 15
D3...D0	FILE	Duration of clock frequency freezing in number of lines: 0000: 0 (no freezing) 0001: 1 : : 1111: 15

Subaddress 11_H

Bit	Name	Function
D7...D4	SYNAMP	Internal amplification of SYNC input signal. Allowed values: SYNAMP = 0000 : amplification 0 dB : SYNC input nom. 2 Vpp SYNAMP = 0110 : amplification 6 dB : SYNC input nom. 1 Vpp
D3...D0	YAMP	Internal amplification of AINY input signal. Allowed values: YAMP = 0000 : amplification 0 dB : AINY input nom. 2 Vpp YAMP = 0110 : amplification 6 dB : AINY input nom. 1 Vpp

Subaddress 12_H

Bit	Name	Function
D7...D4	UAMP	Internal amplification of AINU input signal. Allowed values: UAMP = <u>0000</u> : internal amplification 0 dB : AINU input nom. 2 Vpp UAMP = 0110 : internal amplification 6 dB : AINU input nom. 1 Vpp
D3...D0	VAMP	Internal amplification of AINV input signal. Allowed values: VAMP = <u>0000</u> : amplification 0 dB : AINV input nom. 2 Vpp VAMP = 0110 : internal amplification 6 dB : AINV input nom. 1 Vpp

Subaddress 13_H

Bit	Name	Function
D7...D5	DATDEL	Programmable output delay for PAQ7...PAQ0, PBQ7...PBQ0, BLN, HS, H1I1, H2I2, VS. Allowed values: <u>000</u> 001 (description see chapter 5.3)
D4	DATSLOP	Adaptation of the output driver stages for PAQ7...PAQ0, PBQ7...PBQ0, BLN, HS, H1I1, H2I2, VS. Allowed values: <u>0</u> ... to be used only for 5 V output stage supply voltage 1 ... to be used only for 3.3 V output stage supply voltage and FORMAT = 00
D3...D2	CLKSLOP	Adaptation of the output driver stages for CLK1 and CLK2. Allowed values: <u>00</u> ... to be used only for 5 V output stage supply voltage 10 ... to be used only for 3.3 V output stage supply voltage
D1...D0	<u>00</u>	Reserved

Subaddress 14_H

Bit	Name	Function
D7...D0	0001 0011	Reserved

Subaddress 15_H

Bit	Name	Function
D7...D0	0000 0000	Reserved

Subaddress 16_H

Bit	Name	Function
D7...D0	0000 0000	Reserved

Subaddress 17_H

Bit	Name	Function
D7...D0	0000 0000	Reserved

2.4.5 Read Mode

Status Byte 0

Bit	Name	Function																																																						
D7	CON	Absolute difference between the horizontal sync pulse in SYNC and the HPLL: 0: Larger than or equal to 32 system clock cycles 1: Less than 32 system clock cycles																																																						
D6	THRELIM	Absolute difference between the horizontal sync pulse in SYNC and the HPLL: 0: Larger than 8 system clock cycles 1: Less than 8 system clock cycles for 8 or more successive lines (i.e. HPLL well locked in)																																																						
D5, D4	FFGF, FF	<table border="0"> <tr> <td>Identified number of lines per field (refer also to timing diagram figure 16):</td> <td colspan="2" style="text-align: center;">Status Bits</td> </tr> <tr> <td></td> <td style="text-align: center;">FFGF</td> <td style="text-align: center;">FF</td> </tr> <tr> <td>< N1</td> <td style="text-align: center;">0</td> <td style="text-align: center;">0</td> </tr> <tr> <td>≥ N1 and ≤ N2</td> <td style="text-align: center;">1</td> <td style="text-align: center;">0</td> </tr> <tr> <td>> N2 and < 287</td> <td style="text-align: center;">0</td> <td style="text-align: center;">0</td> </tr> <tr> <td>≥ 287 and < N3</td> <td style="text-align: center;">0</td> <td style="text-align: center;">1</td> </tr> <tr> <td>≥ N3 and ≤ N4</td> <td style="text-align: center;">1</td> <td style="text-align: center;">1</td> </tr> <tr> <td>> N4</td> <td style="text-align: center;">0</td> <td style="text-align: center;">1</td> </tr> <tr> <td colspan="3">N1 to N4 depends on Control Bits VWIWI:</td> </tr> <tr> <td>VWIWI1 VWIWI0</td> <td style="text-align: center;">N1</td> <td style="text-align: center;">N2</td> </tr> <tr> <td>0 0</td> <td style="text-align: center;">262</td> <td style="text-align: center;">264</td> </tr> <tr> <td>0 1</td> <td style="text-align: center;">250</td> <td style="text-align: center;">275</td> </tr> <tr> <td>1 0</td> <td style="text-align: center;">240</td> <td style="text-align: center;">285</td> </tr> <tr> <td>1 1</td> <td style="text-align: center;">200</td> <td style="text-align: center;">312</td> </tr> <tr> <td></td> <td style="text-align: center;">N3</td> <td style="text-align: center;">N4</td> </tr> <tr> <td></td> <td style="text-align: center;">312</td> <td style="text-align: center;">250</td> </tr> <tr> <td></td> <td style="text-align: center;">290</td> <td style="text-align: center;">335</td> </tr> <tr> <td></td> <td style="text-align: center;">250</td> <td style="text-align: center;">362</td> </tr> </table>	Identified number of lines per field (refer also to timing diagram figure 16):	Status Bits			FFGF	FF	< N1	0	0	≥ N1 and ≤ N2	1	0	> N2 and < 287	0	0	≥ 287 and < N3	0	1	≥ N3 and ≤ N4	1	1	> N4	0	1	N1 to N4 depends on Control Bits VWIWI:			VWIWI1 VWIWI0	N1	N2	0 0	262	264	0 1	250	275	1 0	240	285	1 1	200	312		N3	N4		312	250		290	335		250	362
Identified number of lines per field (refer also to timing diagram figure 16):	Status Bits																																																							
	FFGF	FF																																																						
< N1	0	0																																																						
≥ N1 and ≤ N2	1	0																																																						
> N2 and < 287	0	0																																																						
≥ 287 and < N3	0	1																																																						
≥ N3 and ≤ N4	1	1																																																						
> N4	0	1																																																						
N1 to N4 depends on Control Bits VWIWI:																																																								
VWIWI1 VWIWI0	N1	N2																																																						
0 0	262	264																																																						
0 1	250	275																																																						
1 0	240	285																																																						
1 1	200	312																																																						
	N3	N4																																																						
	312	250																																																						
	290	335																																																						
	250	362																																																						
D3		don't care																																																						
D2 ... D0	POR	Status bit POR is set by power on reset or by activating the reset pin. POR is reset after reading the status byte.																																																						

Status Byte 1

Bit	Name	Function
D7...D6		don't care
D5	OFLY	Overflow detection of ADC for input AINY
D4	UFLY	Underflow detection of ADC for input AINY
D3	OFLU	Overflow detection of ADC for input AINU
D2	UFLU	Underflow detection of ADC for input AINU
D1	OFLV	Overflow detection of ADC for input AINV
D0	UFLV	Underflow detection of ADC for input AINV

3 Absolute Maximum Ratings

Parameter	Symbol	Limit Values		Unit	Remark
		min.	max.		
Storage temperature	T_{stg}	- 40	125	°C	
Soldering temperature	T_{sold}		260	°C	
Soldering time	t_{sold}		10	sec	
Input/output voltage	$V_{\text{I/Q}}$	$V_{\text{SSQ}} - 0.3 \text{ V}$	$V_{\text{DDQ}} + 0.3 \text{ V}$	1	Not valid for I ² C-Bus pins
Input/output voltage I ² C-pins 33, 34 (SCL, SDA)	$V_{\text{I/Q, I2C}}$	$V_{\text{SSQ}} - 0.3 \text{ V}$	6 V	1	
Power supply voltage	$V_{\text{DD}},$ $V_{\text{ADDx}},$ $V_{\text{DDQ}},$ V_{DDTO}	- 0.3	6	V	
Total power dissipation	P_{tot}		1.25	W	
Latch-up protection		- 100	100	mA	All inputs/outputs
ESD protection	ESD	- 1	1	kV	MIL STD 883C method 3015-6, 100 pF, 1500 Ω

All voltages listed are referenced to ground (0 V, V_{SS}) except where noted.

Note: Absolute maximum ratings are those values beyond which damage to the device may occur. Functional operation under these conditions or at any other condition beyond those indicated in the operational sections of this specification is not implied.

3.1 Recommended Operating Conditions

Parameter	Symbol	Limit Values			Unit	Remark
		min.	nom.	max.		
Ambient temperature	T_A	0	25	70	°C	

Power Requirements

Analog supply voltage	V_{ADDx}	4.75	5.0	5.25	V	
Digital supply voltage	V_{DD}	4.75	5.0	5.25	V	
DTO supply voltage	V_{DDDTO}	4.75	5.0	5.25	V	
Output stage supply voltage	V_{DDQ}	4.75	5.0	5.25	V	5 V-Mode
		3.0	3.3	3.6	V	3.3 V mode, only to be used for FORMAT = 00
Supply voltage differential	$V_{DD, diff}$	- 0.25		0.25	V	Supply pins V_{ADDx}

All TTL Inputs

H-input voltage	V_{IH}	2.0V		V_{DDQ}	1	
L-input voltage	V_{IL}	0		0.8	V	

I²C-Bus (Values are Referred to min. (V_{IH}) and max. (V_{IL}))

H-input voltage	V_{IH}	$0.7 \times V_{DDQ}$		V_{DD}	1	
L-input voltage	V_{IL}	0V		$0.3 \times V_{DDQ}$	1	
SCL clock frequency	f_{SCL}	0		400	kHz	
Rise times of SCL, SDA	t_R			0.3	μs	
Fall times of SCL, SDA	t_F			0.3	μs	
Set-up time data	$t_{SU, Dat}$	100			ns	
Hold time data	$t_{HD, Dat}$	0			ns	
Bus free time before start condition	t_{Buf}	1.3			μs	
Set-up time start condition	$t_{SU, Sta}$	0.6			μs	
Hold time start condition	$t_{HD, Sta}$	0.6			μs	

3.1 Recommended Operating Conditions (cont'd)

Parameter	Symbol	Limit Values			Unit	Remark
		min.	nom.	max.		
SCL low time	t_{Low}	1.3			μs	
SCL high time	t_{High}	0.6			μs	
Load capacitance				400	pF	

Reference Inputs for Analog Inputs AINY, AINU, AINV, SYNC

Reference voltage high	V_{REFHx}	3.2	4.2	4.7	V	$V_{ADDx} = 5 V$
Reference voltage low	V_{REFLx}	1.7	2.2	3.2	V	

Analog Inputs AINY, AINU, AINV

Input range (Peak-Peak)	V_{IPP}		2 V	$V_{REFHx} - V_{REFLx}$	1	YAMP, UAMP, VAMP = 0000, Prefiltering see chapter 2.1.2
Required ext clamp capacitance	$C_{ext cl}$		100		nF	AINY, AINU, AINV each
Required signal source resistance	R_S	0		200	Ω	

SYNC Input for Sync and Clock Generation

Input range (Peak-Peak)	V_{IPP}	0.5 V	2 V	$V_{REFHC} - V_{REFLC}$	1	SYNAMP = 0000
Input frequency	f	0		12	MHz	To avoid aliasing
Required ext clamp capacitance	$C_{ext cl}$		100		nF	
Required signal source resistance	R_S			200	Ω	

Inputs Crystal Connections X1, X2

Crystal frequency	f_c		24.576		MHz	
-------------------	-------	--	--------	--	-----	--

Crystal Type Fundamental Crystal

Equivalent parallel C	C_O		3.6		pF	
Crystal resonant impedance	Z_R			40	Ω	
Pin capacitance	C_I			10	pF	
External capacitance	C_{ext}		18		pF	Each

3.2 Characteristics (Assuming Recommended Operating Conditions)

Parameter	Symbol	Limit Values			Unit	Remark
		min.	nom.	max.		
Supply Currents						
Analog supply current	I_{ADD}		120		mA	Sum of all V_{ADDx} pins
Digital supply current	I_{DD}		40		mA	Sum of all V_{DD} pins + V_{DDTO}
Output stage supply current	I_{DDQ}		40		mA	Sum of all V_{DDQ} pins
Reference Inputs for Analog Inputs AINY, AINU, AINV						
Reference ladder resistance	R_{REF}	175	250	325	Ω	For each converter between REFH and REFL
Reference Inputs for Analog Input SYNC						
Reference ladder resistance	R_{REF}	280	400	520	Ω	For each converter between REFH and REFL
All TTL Inputs						
Input current		- 300		300	μ A	$V_I = 0\text{ V} \dots V_{DDQ}$ Note: internal pullup/pulldown-circuits
I²C Input/Output SDA						
L-output voltage	V_{QL}			0.6	V	$I = 4\text{ mA}$
Analog Inputs						
Analog input leakage current	I_{AIN}	- 100		100	nA	AINY, AINU, AINV, SYNC each
Analog input capacitance	C_1			10	pF	AINY, AINU, AINV, SYNC each
TTL Outputs Port A, Port B, VS, HS, BLN, H1, H2, RESOUTN ($V_{DDQ} = 3.3\text{ V}$ or 5 V)						
L-output voltage	V_{QL}	0		0.4	V	$I = 1\text{ mA}$
H-output voltage	V_{QH}	2.4 V		V_{DDQ}	1	$I = -0.5\text{ mA}$
High impedance state output current	I_{QZ}	- 20		20	μ A	$V_Q = 0\text{ V} \dots V_{DDQ}$ Port A, Port B, VS, HS, BLN
Load capacitance	C_L			25	pF	

3.2 Characteristics (Assuming Recommended Operating Conditions) (cont'd)

Parameter	Symbol	Limit Values			Unit	Remark
		min.	nom.	max.		
Output data delay time, t_{QD} referenced to CLK1 (not valid for ESOUTN)				25	ns	DATDEL = 000 $C_L = 15$ pF 5 V output stage supply voltage, DATSLOP = 0
				35	ns	DATDEL = 000 $C_L = 25$ pF 5 V output stage supply voltage, DATSLOP = 0
				25	ns	DATDEL = 000 $C_L = 25$ pF 3.3 V output stage supply voltage, FORMAT = 00 DATSLOP = 1
Output data hold time, t_{QH} referenced to CLK1 (not valid for RESOUTN)	t_{QH}	6			ns	
Pin RESOUTN Data delay/ data hold time		-	-	-		Asynchronous output signal

Clock TTL Outputs CLK1, CLK2

L-output voltage	V_{QL}	0		0.4	V	$I = 1$ mA
H-output voltage	V_{QH}	2.4 V		V_{DD}	1	$I = -0.5$ mA
Load capacitance	C_L			30	pF	
Transition times	t_R, t_F			5	ns	5 V output stage supply voltage, CLKSLOP = 00 3.3 V output stage supply voltage, CLKSLOP = 10

3.2 Characteristics (Assuming Recommended Operating Conditions) (cont'd)

Parameter	Symbol	Limit Values			Unit	Remark
		min.	nom.	max.		
Low time 13.5 MHz	t_{WL13}	26			ns	13.5 MHz
High time 13.5 MHz	t_{WH13}	26			ns	13.5 MHz
Low time 27 MHz	t_{WL27}	10			ns	27 MHz
High time 27 MHz	t_{WH27}	10			ns	27 MHz
Skew	t_{SK}	- 2	0	2	ns	$C_{L,CLK1} = C_{L,CLK2}$
Frequency range when PLL is locked at SYNC input signal	f	25	27	35	MHz	± 4.8% at 27 MHz S1CL = 11, S2CL = 11

Performance of A/D Conversion (8-Bit)

Test Conditions: ADC Clock = 27 MHz, DATDEL = 000, xAMP = 0000, VIPP = 2 Vpp

Sampling rate			27		MHz	
Differential linearity (DC)	DNLE			± 0.5	LSB	
Integral linearity (DC)	INLE			± 1	LSB	
Clamping level accuracy	CLA		0.5	± 3	LSB	
Gain error (DC)	GE			± 6	LSB	
Gain matching error (DC)	GME			± 3	LSB	
Differential gain	DG			3	%	Not tested
Differential phase	DP			3	deg	Not tested
Signal to noise ratio at 4.4 MHz sinus	$\alpha_{S/N}$	45	48		dB	Without harmonics

Harmonic Distortion

2./4. order				- 42	dB	4.4 MHz fundamental
3. order				- 42	dB	4.4 MHz fundamental
5./6. order				- 48	dB	4.4 MHz fundamental

4 Application Information

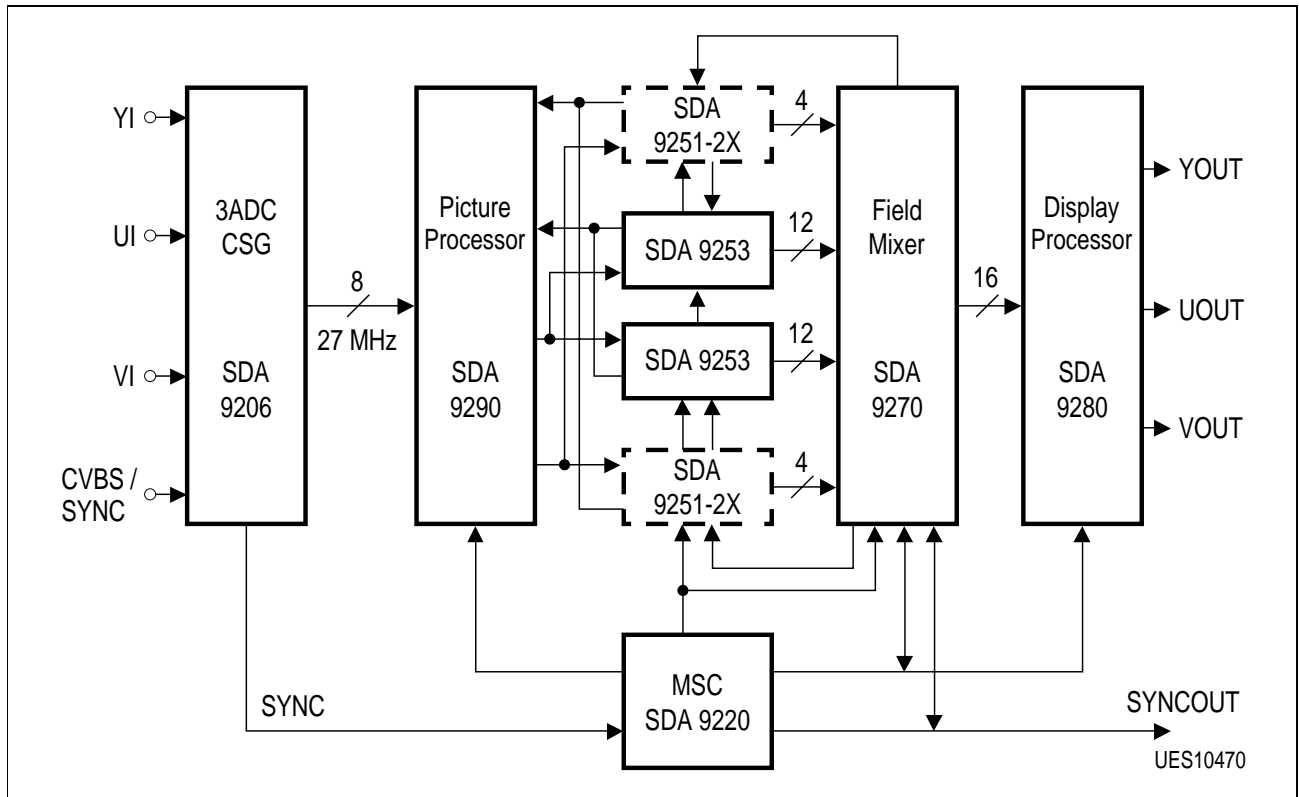

Figure 18
Application Circuit 1

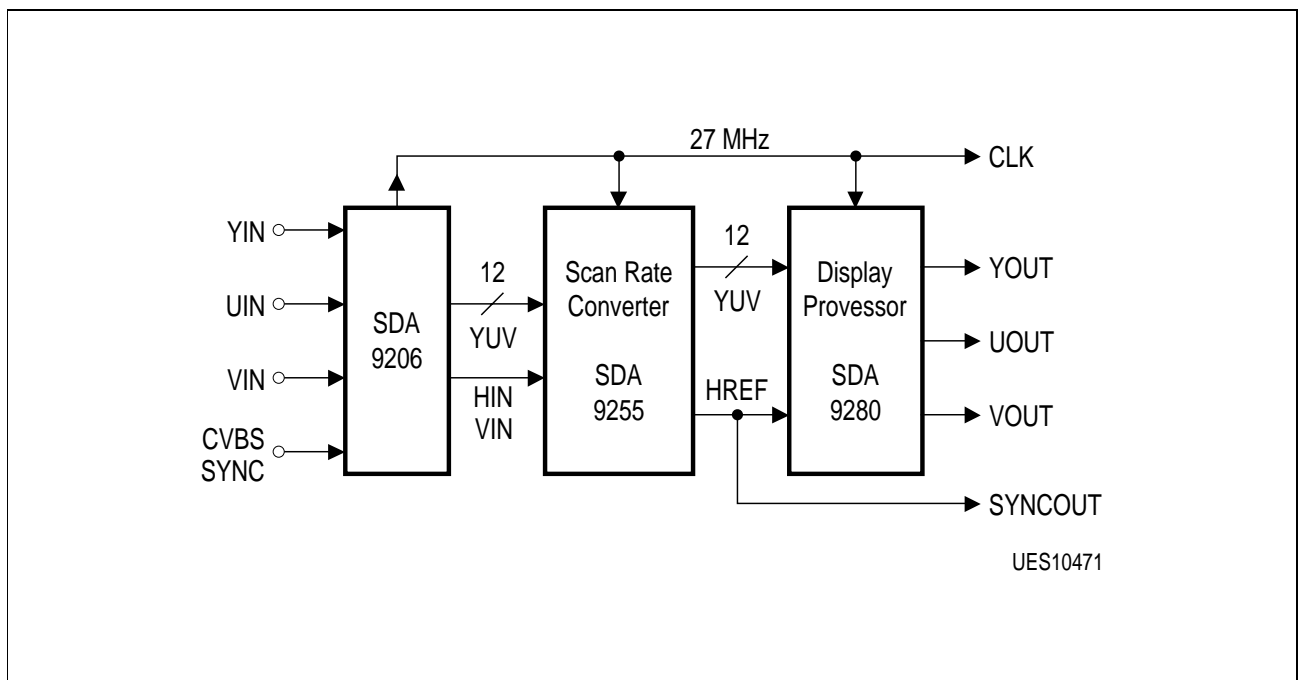

Figure 19
Application Circuit 2

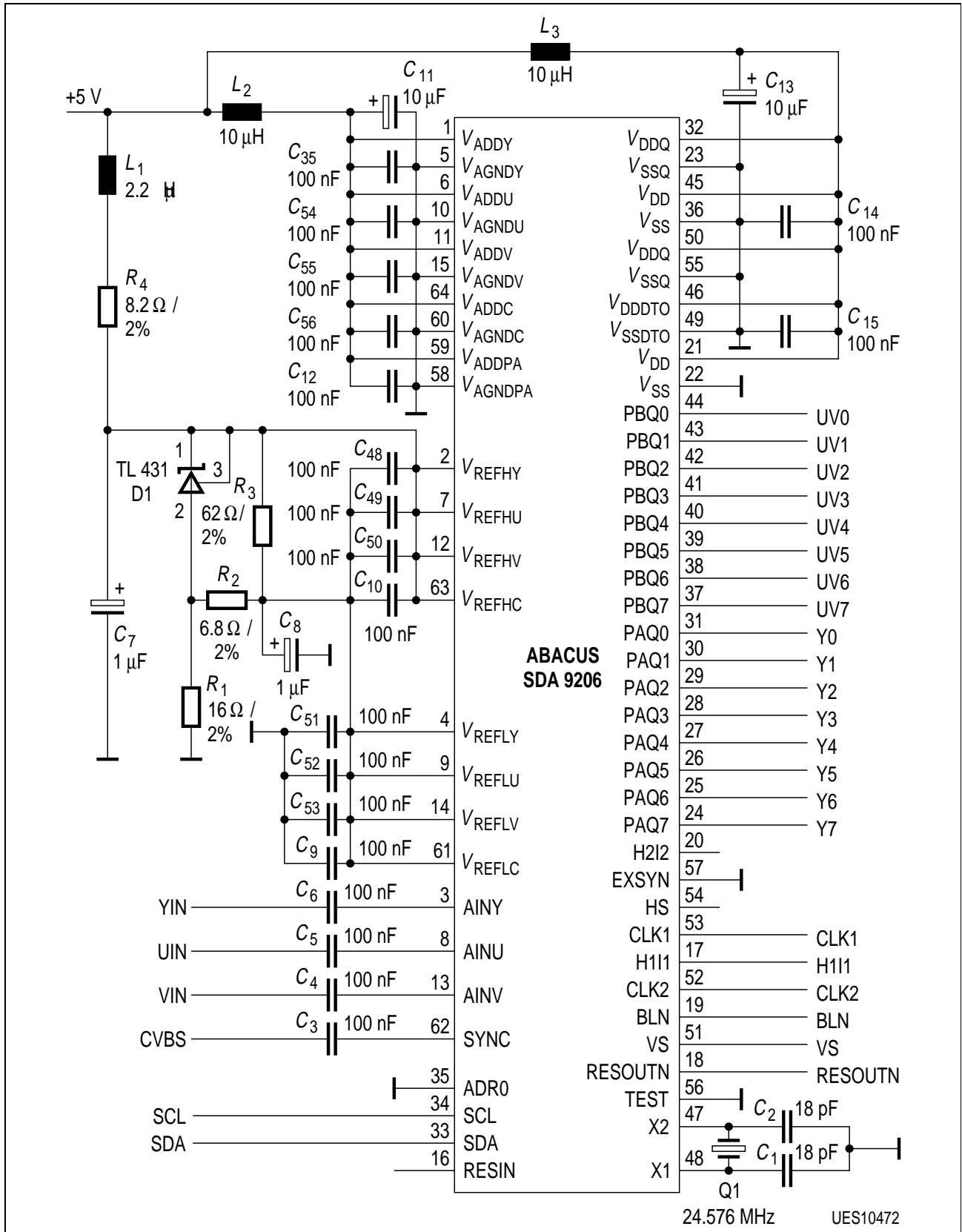

Figure 20
Application Circuit 3

5 Waveforms

5.1 Timing Diagram Data Input/Output Referenced to the Clock CLK1

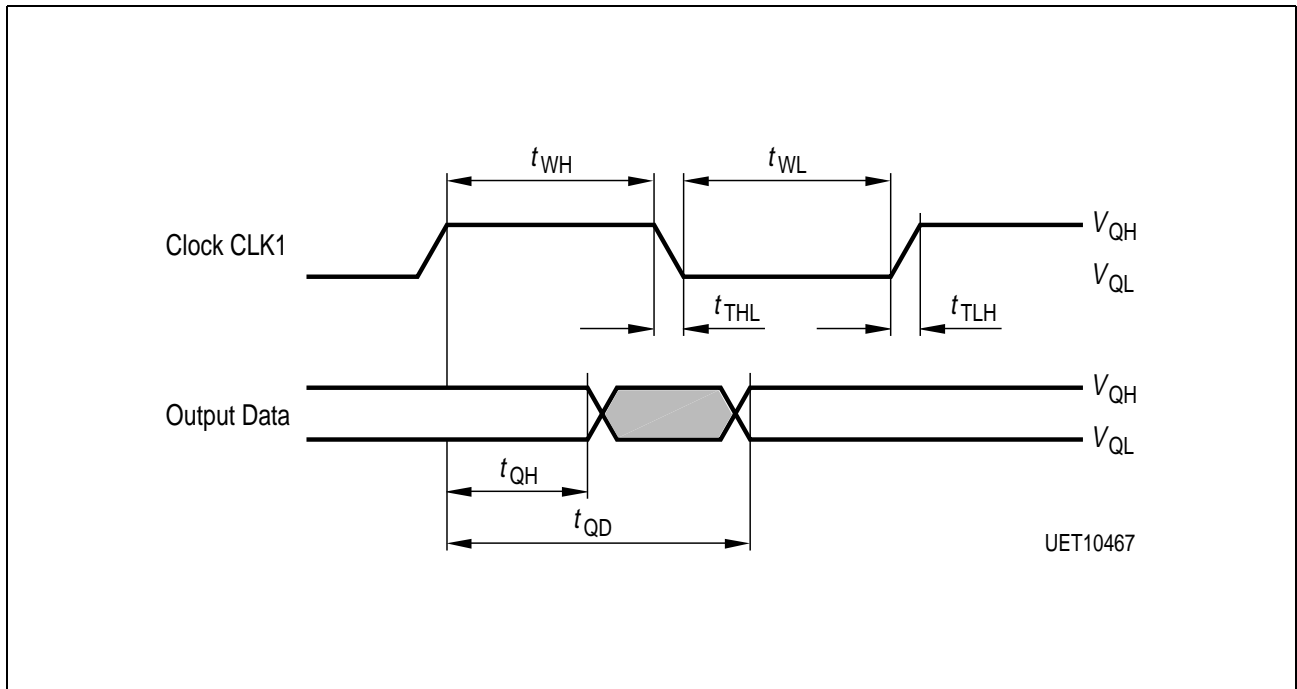

Figure 21

5.2 Timing Diagram Clock Skew CLK2 - CLK1

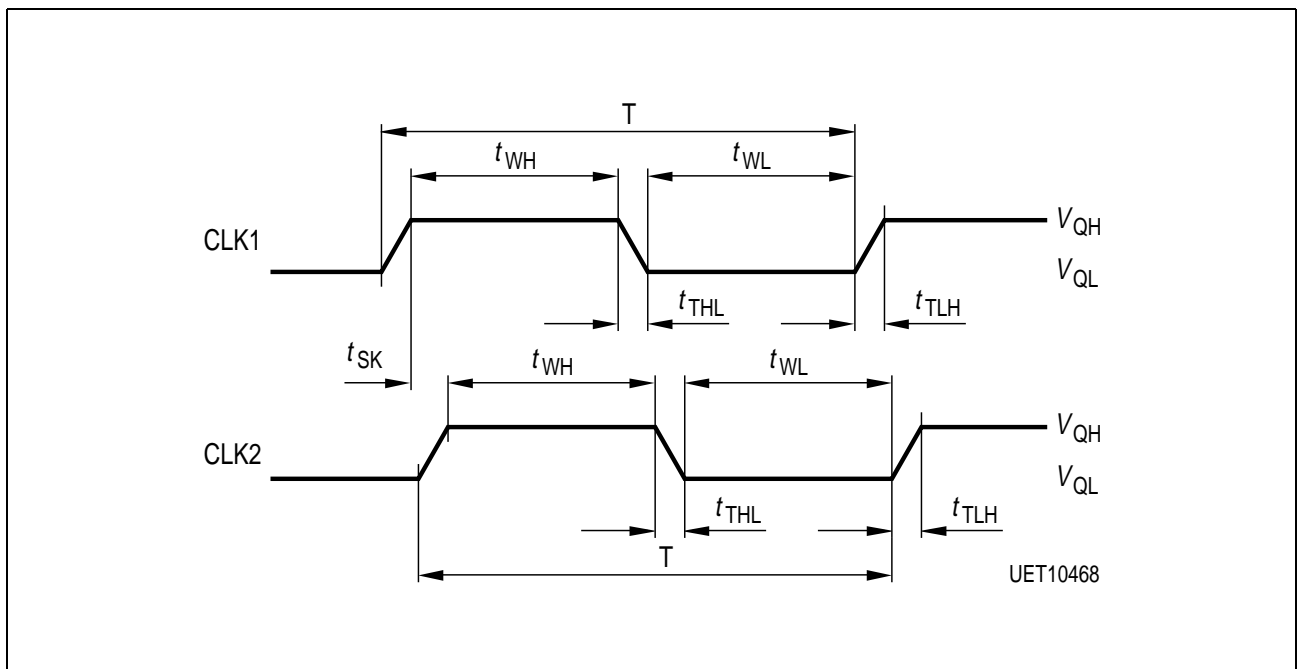

Figure 22

5.3 Programmable Data Output Delay:
DAT_OUT: Pins PAQ7...0, PBQ7...0, BLN, HS, H1I1, H2I2 and VS

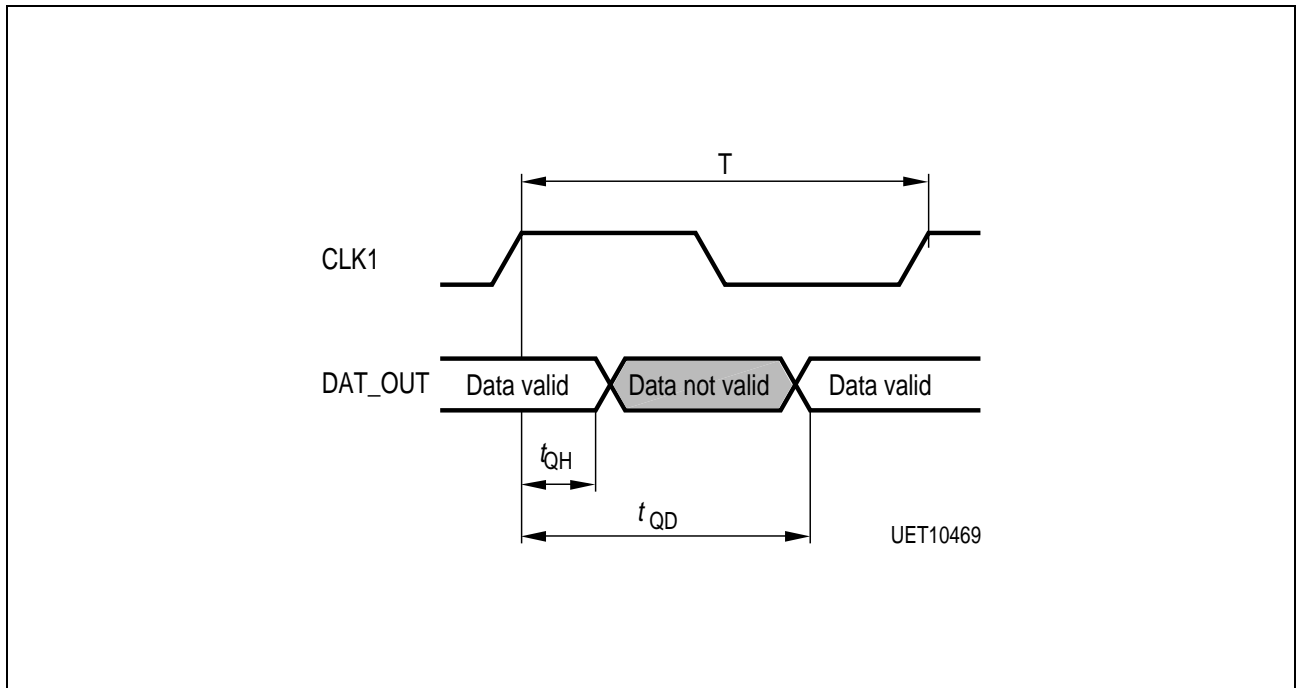

Figure 23

DATDEL	t_{QH} ; min.	t_{QD} ; max.
000	6 ns	25 ns
001	10 ns	29 ns

The delay times are valid for a clock rate of the analog PLL of 27 MHz.

6 Package Outlines

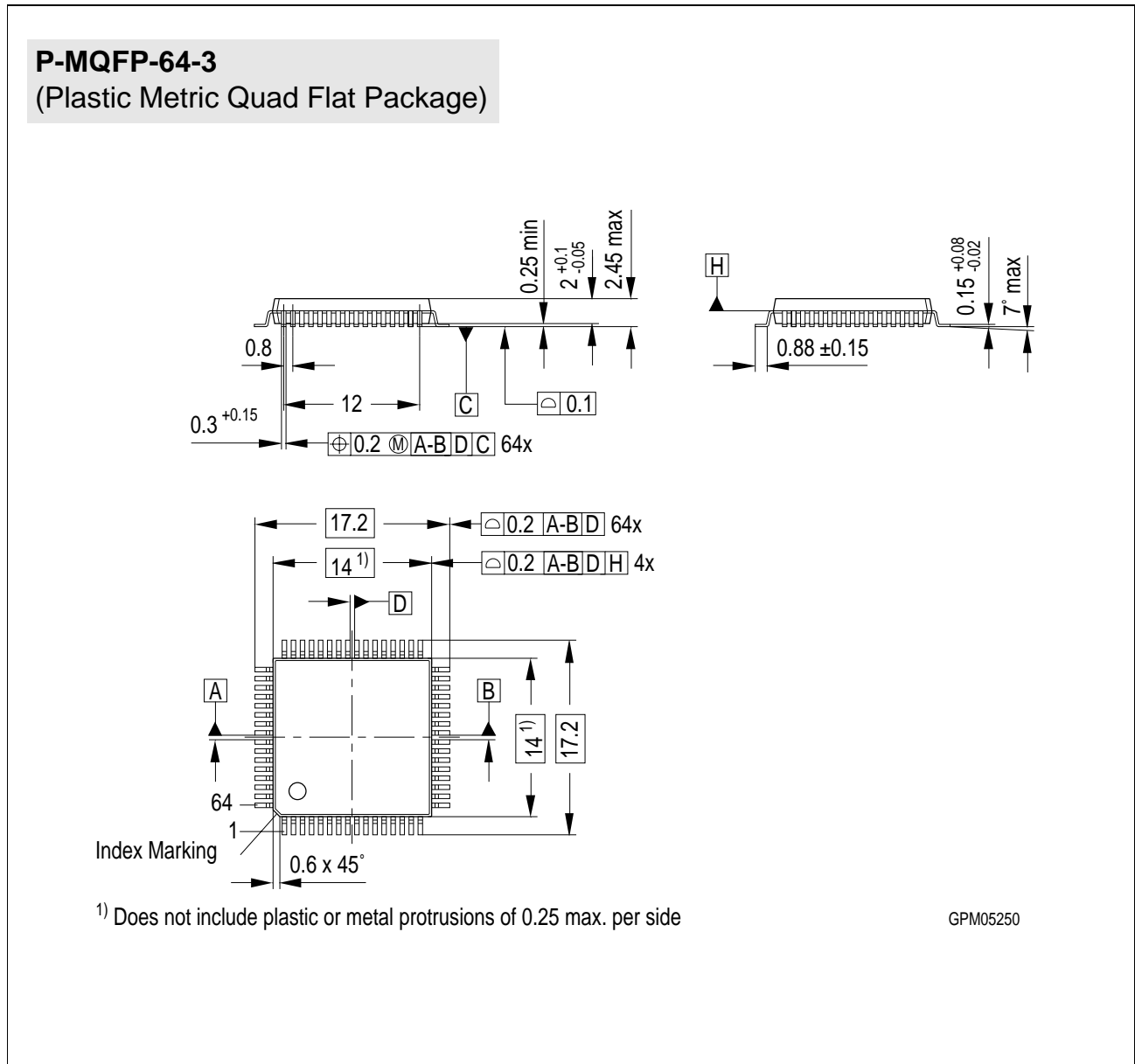

Figure 24

Sorts of Packing

Package outlines for tubes, trays etc. are contained in our Data Book "Package Information".

SMD = Surface Mounted Device

Dimensions in mm