

Low Skew Zero Delay Buffer

FEATURES

- Frequency Range 10MHz to 220MHz
- Zero input - output delay.
- Low Output to Output Skew
- Optional Drive Strength:
Standard (8mA) PL123E-09
High (12mA) PL123E-09H
- 2.5V or 3.3V, $\pm 10\%$ operation.
- Available in 16-Pin SOP or TSSOP packages

DESCRIPTION

The PL123E-09 (-09H for High Drive) is a high performance, low skew, low jitter zero delay buffer designed to distribute high speed clocks. It has two low-skew output banks, of 4 outputs each, that are synchronized with the input. Control of the two banks of outputs is achieved by using the S1 and S2 inputs as shown in the Selector Definition table on page 2.

The synchronization is established via CLKOUT feed back to the input of the PLL. Since the skew between the input and output is less than $\pm 100\text{ps}$, the device acts as a zero delay buffer. The input output propagation delay can be advanced or delayed by adjusting the load on the CLKOUT pin.

These parts are not intended for 5V input-tolerant applications.

BLOCK DIAGRAM

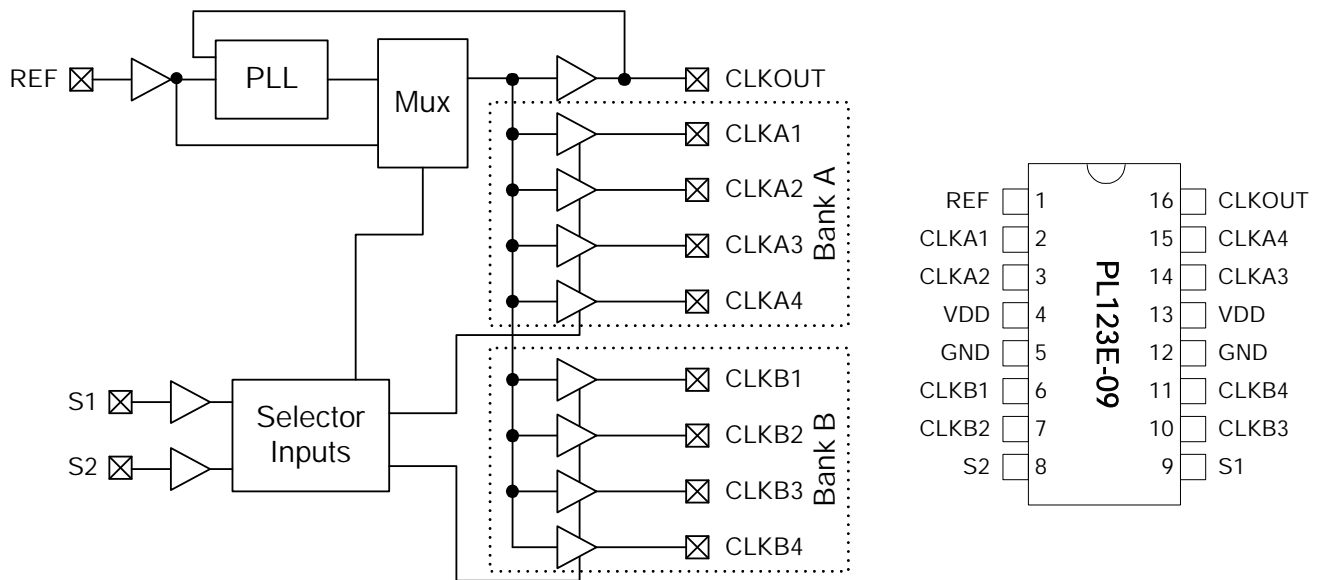

Low Skew Zero Delay Buffer

PIN DESCRIPTIONS

Name	Package Type		Type	Description
	TSSOP-16L	SOP-16L		
REF ^[1]	1	1	I	Input reference frequency.
CLKA1 ^[2]	2	2	O	Buffered clock output, Bank A
CLKA2 ^[2]	3	3	O	Buffered clock output, Bank A
VDD	4,13	4,13	P	VDD connection
GND	5,12	5,12	P	GND connection
CLKB1 ^[2]	6	6	O	Buffered clock output, Bank B
CLKB2 ^[2]	7	7	O	Buffered clock output, Bank B
S2 ^[3]	8	8	I	Selector input
S1 ^[3]	9	9	I	Selector input
CLKB3 ^[2]	10	10	O	Buffered clock output, Bank B
CLKB4 ^[2]	11	11	O	Buffered clock output, Bank B
CLKA3 ^[2]	14	14	O	Buffered clock output, Bank A
CLKA4 ^[2]	15	15	O	Buffered clock output, Bank A
CLKOUT ^[2]	16	16	O	Buffered clock output. Internal feedback on this pin.

Notes: 1: Weak pull-down. 2: Weak pull-down on all outputs. 3: Weak Pull-Up on S1 and S2

SELECTOR DEFINITION

S2	S1	CLOCK A1-A4 (Bank A)	CLOCK B1-B4 (Bank B)	CLKOUT	Output Source	PLL Shutdown
0	0	Three-state	Three-state	Driven	PLL	N
0	1	Driven	Three-state	Driven	PLL	N
1	0	Driven	Driven	Driven	Reference	Y
1	1	Driven	Driven	Driven	PLL	N

INPUT / OUTPUT SKEW CONTROL

The PL123E-09 will achieve Zero Delay from input to output when all the outputs are loaded equally. Adjustments to the input/output delay can be made by adding additional loading to the CLKOUT pin. Please contact PhaseLink for more information.

Low Skew Zero Delay Buffer

LAYOUT RECOMMENDATIONS

The following guidelines are to assist you with a performance optimized PCB design:

Signal Integrity and Termination Considerations

- Keep traces short!
- Trace = Inductor. With a capacitive load this equals ringing!
- Long trace = Transmission Line. Without proper termination this will cause reflections (looks like ringing).
- Design long traces as "striplines" or "microstrips" with defined impedance.
- Match trace at one side to avoid reflections bouncing back and forth.

Decoupling and Power Supply Considerations

- Place decoupling capacitors as close as possible to the VDD pin(s) to limit noise from the power supply
- Addition of a ferrite bead in series with VDD can help prevent noise from other board sources
- Value of decoupling capacitor is frequency dependent. Typical values to use are 0.1 μ F for designs using frequencies < 50MHz and 0.01 μ F for designs using frequencies > 50MHz.

Typical CMOS termination

Place Series Resistor as close as possible to CMOS output

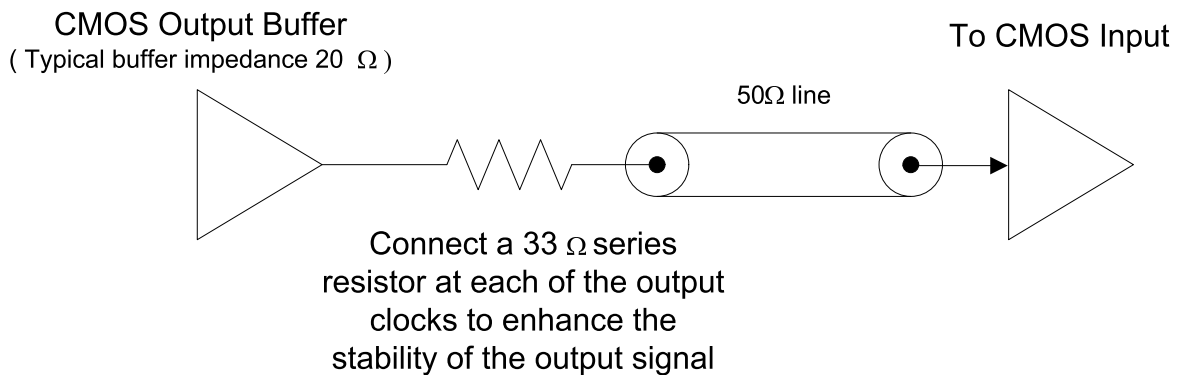

Low Skew Zero Delay Buffer

ABSOLUTE MAXIMUM CONDITIONS

Supply Voltage to Ground Potential -0.5V to 4.6V
 DC Input Voltage..... V_{SS} - 0.5V to 4.6V
 Storage Temperature -65°C to 150°C

Junction Temperature 150°C
 Static Discharge Voltage
 (per MIL-STD-883, Method 3015)..... > 2000V

OPERATING CONDITIONS

Description	Parameter	Min	Max	Unit
Supply Voltage	V_{DD}	2.25	3.63	V
Load Capacitance, <100 MHz, 3.3V	$C_L^{[4]}$	-	30	pF
Load Capacitance, <100 MHz, 2.5V with High Drive		-	30	pF
Load Capacitance, <133.3 MHz, 3.3V		-	22	pF
Load Capacitance, <133.3 MHz, 2.5V with High Drive		-	22	pF
Load Capacitance, <133.3 MHz, 2.5V with Standard Drive		-	15	pF
Load Capacitance, >133.3 MHz, 3.3V		-	15	pF
Load Capacitance, >133.3 MHz, 2.5V with High Drive		-	15	pF
Input Capacitance ^[5]	C_{IN}	-	5	pF
Closed-loop bandwidth (typical), 3.3V	BW	1		MHz
Closed-loop bandwidth (typical), 2.5V		0.5		MHz
Output Impedance (typical), 3.3V High Drive	R_{OUT}	23		Ω
Output Impedance (typical), 3.3V Standard Drive		33		Ω
Output Impedance (typical), 2.5V High Drive		26		Ω
Output Impedance (typical), 2.5V Standard Drive		39		Ω
Power-up time for all V_{DD} 's to reach minimum specified voltage (power ramps must be monotonic)	t_{PU}	0.01	250	ms

Notes:

4. Applies to Test Circuit #1.
5. Applies to both REF Clock and internal feedback path on CLKOUT.
6. Theta Ja, EIA JEDEC 51 test board conditions, 2S2P; Theta Jc Mil-Spec 883E Method 1012.1.

Low Skew Zero Delay Buffer

3.3V DC ELECTRICAL SPECIFICATIONS

Description	Parameter	Test Conditions	Min	Max	Unit
Supply Voltage	V_{DD}		2.97	3.63	V
Input LOW Voltage	V_{IL}		-	0.8	V
Input HIGH Voltage	V_{IH}		2.5	$V_{DD} + 0.3$	V
Input Leakage Current	I_{IL}	$0 < V_{IN} < V_{IL}$	-	± 10	μA
Input HIGH Current	I_{IH}	$V_{IN} = V_{DD}$	-	100	μA
Output LOW Voltage	V_{OL}	$I_{OL} = 8 \text{ mA}$ (Standard Drive) $I_{OL} = 12 \text{ mA}$ (High Drive)	- -	0.4 0.4	V V
Output HIGH Voltage	V_{OH}	$I_{OH} = -8 \text{ mA}$ (Standard Drive) $I_{OH} = -12 \text{ mA}$ (High Drive)	2.4 2.4	- -	V V
Supply Current	I_{DD}	Unloaded outputs, 66-MHz REF	-	45	mA

2.5V DC ELECTRICAL SPECIFICATIONS

Description	Parameter	Test Conditions	Min	Max	Unit
Supply Voltage	V_{DD}		2.25	2.75	V
Input LOW Voltage	V_{IL}		-	0.7	V
Input HIGH Voltage	V_{IH}		1.7	$V_{DD} + 0.3$	V
Input Leakage Current	I_{IL}	$0 < V_{IN} < V_{IL}$	-	± 10	μA
Input HIGH Current	I_{IH}	$V_{IN} = V_{DD}$	-	100	μA
Output LOW Voltage	V_{OL}	$I_{OL} = 8 \text{ mA}$ (Standard Drive) $I_{OL} = 12 \text{ mA}$ (High Drive)	- -	0.5 0.5	V V
Output HIGH Voltage	V_{OH}	$I_{OH} = -8 \text{ mA}$ (Standard Drive) $I_{OH} = -12 \text{ mA}$ (High Drive)	$V_{DD} - 0.6$ $V_{DD} - 0.6$	- -	V V
Supply Current	I_{DD}	Unloaded outputs, 66-MHz REF	-	30	mA

Low Skew Zero Delay Buffer

3.3V AND 2.5V AC ELECTRICAL SPECIFICATIONS

Description	Parameter	Test Conditions	Min	Typ	Max	Unit
Maximum Frequency ^[7] (Input/Output)	1/t ₁	3.3V High Drive	10	–	220	MHz
		3.3V Standard Drive	10	–	167	MHz
		2.5V High Drive	10	–	200	MHz
		2.5V Standard Drive	10	–	134	MHz
Input Duty Cycle (PLL Mode only)	T _{IDC}	<133.3 MHz	25	–	75	%
		>133.3 MHz	40	–	60	%
Output Duty Cycle ^[8]	t ₂ ÷ t ₁	<133.3 MHz	47	–	53	%
		>133.3 MHz	45	–	55	%
Rise, Fall Time (3.3V) ^[8]	t ₃ , t ₄	Standard Drive, CL = 30 pF, <100 MHz	–	1.6	–	ns
		Standard Drive, CL = 22 pF, <133.3 MHz	–	1.6	–	ns
		Standard Drive, CL = 15 pF, <167 MHz	–	0.6	–	ns
		High Drive, CL = 30 pF, <100 MHz	–	1.2	–	ns
		High Drive, CL = 22 pF, <133.3 MHz	–	1.2	–	ns
		High Drive, CL = 15 pF, >133.3 MHz	–	0.5	–	ns
Rise, Fall Time (2.5V) ^[8]	t ₃ , t ₄	Standard Drive, CL = 15 pF, <133.33 MHz	–	1.5	–	ns
		High Drive, CL = 30 pF, <100 MHz	–	2.1	–	ns
		High Drive, CL = 22 pF, <133.3 MHz	–	1.3	–	ns
		High Drive, CL = 15 pF, >133.3 MHz	–	1.2	–	ns
Output to Output Skew ^[8]	t ₅	All outputs equally loaded	–	–	100	ps
Delay, REF Rising Edge to CLKOUT Rising Edge ^[8]	t ₆	PLL enabled @ 3.3V	–100	–	100	ps
		PLL enabled @2.5V	–200	–	200	ps
Part to Part Skew ^[8]	t ₇	Measured at V _{DD} /2. Any output to any output, 3.3V supply	–	–	±150	ps
		Measured at V _{DD} /2. Any output to any output, 2.5V supply	–	–	±300	ps
PLL Lock Time ^[8]	t _{LOCK}	Stable power supply, valid clocks presented on REF and CLKOUT pins	–	–	1.0	ms
Cycle-to-Cycle Jitter, Peak ^[8, 9]	T _{JCC}	3.3V, >66 MHz, <15 pF	–	–	55	ps
		3.3V, >66 MHz, <30 pF, Standard. Drive	–	–	125	ps
		3.3V, >66 MHz, <30 pF, High Drive	–	–	100	ps
		2.5V, >66 MHz, <15 pF, Standard. Drive	–	–	95	ps
		2.5V, >66 MHz, <15 pF, High Drive	–	–	65	ps
		2.5V, >66 MHz, <30 pF, High Drive	–	–	145	ps

Low Skew Zero Delay Buffer

3.3V AND 2.5V AC ELECTRICAL SPECIFICATIONS (continued)

Description	Parameter	Test Conditions	Min	Typ	Max	Unit
Period Jitter, Peak ^[8,9]	T _{PER}	3.3V, 66–100 MHz, <15 pF	–	–	75	ps
		3.3V, >100 MHz, <15 pF	–	–	45	ps
		3.3V, >66 MHz, <30 pF, Standard Drive	–	–	100	ps
		3.3V, >66 MHz, <30 pF, High Drive	–	–	70	ps
		2.5V, >66 MHz, <15 pF, Standard. Drive	–	–	60	ps
		2.5V, 66–100 MHz, <15 pF, High Drive	–	–	60	ps
		2.5V, >100 MHz, <15 pF, High Drive	–	–	45	ps

Notes:

- 7. For the given maximum loading conditions. See C_L in Operating Conditions Table.
- 8. Parameter is guaranteed by design and characterization. Not 100% tested in production.
- 9. Typical jitter is measured at 3.3V or 2.5V, 29°C, with all outputs driven into the maximum specified load.

Low Skew Zero Delay Buffer

SWITCHING WAVEFORMS

Duty Cycle Timing

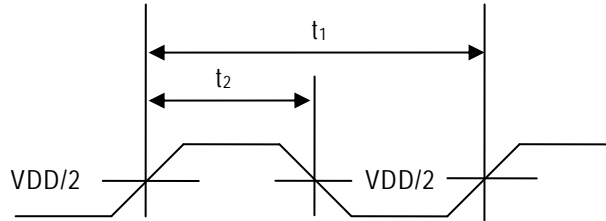

All Outputs Rise/Fall Time

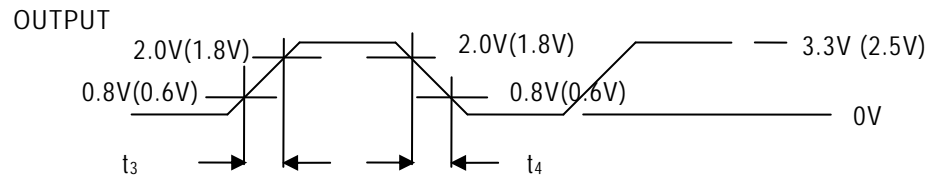

Output-Output Skew

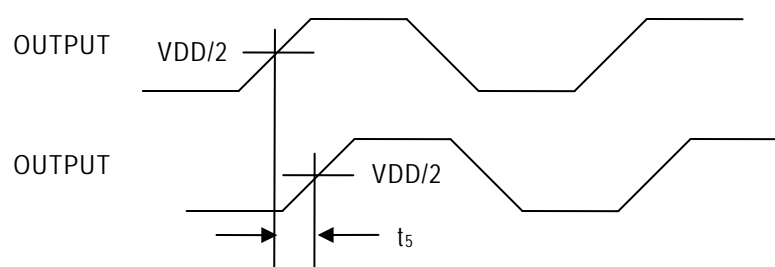

Input-Output Propagation Delay

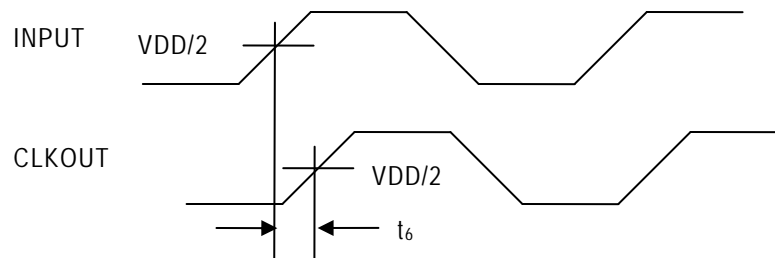

Device-Device Skew

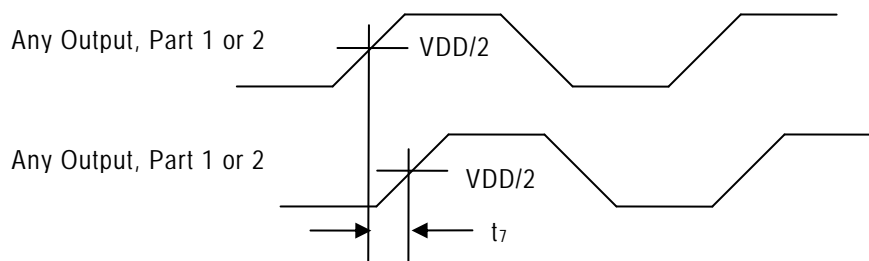

Low Skew Zero Delay Buffer

TEST CIRCUITS

Test Circuit #1

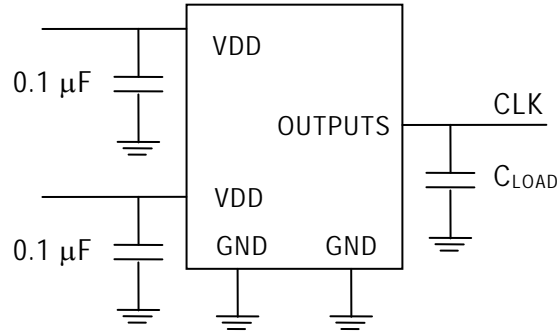

PACKAGE DRAWINGS (GREEN PACKAGE COMPLIANT)

16 PIN Narrow SOP, TSSOP (mm)

Symbol	SOP		TSSOP	
	Min.	Max.	Min.	Max.
A	1.35	1.75	-	1.20
A1	0.10	0.25	0.05	0.15
B	0.33	0.51	0.19	0.30
C	0.19	0.25	0.09	0.20
D	9.80	10.00	4.90	5.10
E	3.80	4.00	4.30	4.50
H	5.80	6.20	6.40 BSC	
L	0.40	1.27	0.45	0.75
e	1.27 BSC		0.65 BSC	

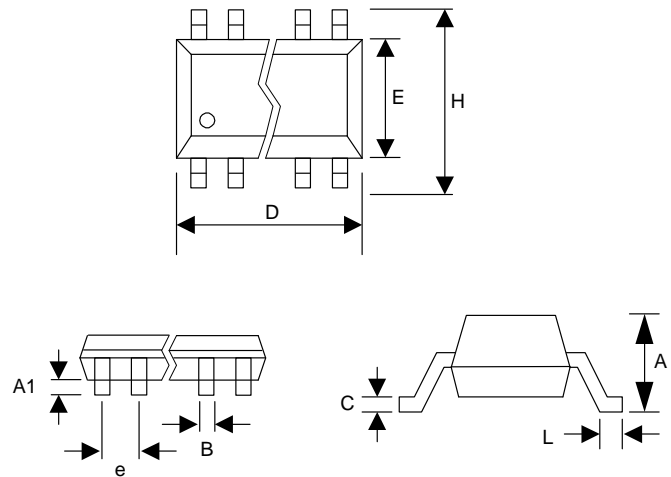

Low Skew Zero Delay Buffer

ORDERING INFORMATION (GREEN PACKAGE COMPLIANT)

For part ordering, please contact our Sales Department:
47745 Fremont Blvd., Fremont, CA 94538, USA
Tel: (510) 492-0990 Fax: (510) 492-0991

PART NUMBER

The order number for this device is a combination of the following:
Device number, Package type and Operating temperature range

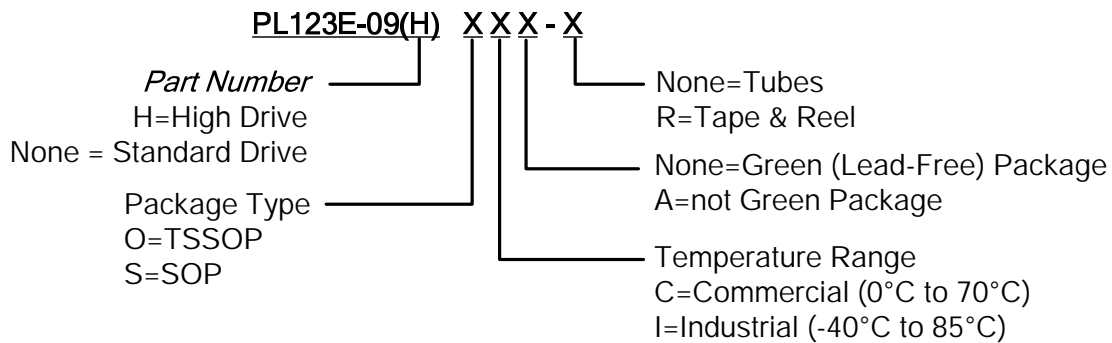

Part/Order Number	Marking	Package Option
PL123E-09OC	P123E-09	16-Pin TSSOP Tube
PL123E-09OC-R	P123E-09	16-Pin TSSOP (Tape and Reel)
PL123E-09HOC	P123E-09H	16-Pin TSSOP Tube
PL123E-09HOC-R	P123E-09H	16-Pin TSSOP (Tape and Reel)
PL123E-09SC	P123E-09	16-Pin SOP Tube
PL123E-09SC-R	P123E-09	16-Pin SOP (Tape and Reel)
PL123E-09HSC	P123E-09H	16-Pin SOP Tube
PL123E-09HSC-R	P123E-09H	16-Pin SOP (Tape and Reel)
PL123E-09OI	P123E-09	16-Pin TSSOP Tube
PL123E-09OI-R	P123E-09	16-Pin TSSOP (Tape and Reel)
PL123E-09HOI	P123E-09H	16-Pin TSSOP Tube
PL123E-09HOI-R	P123E-09H	16-Pin TSSOP (Tape and Reel)
PL123E-09SI	P123E-09	16-Pin SOP Tube
PL123E-09SI-R	P123E-09	16-Pin SOP (Tape and Reel)
PL123E-09HSI	P123E-09H	16-Pin SOP Tube

PhaseLink Corporation, reserves the right to make changes in its products or specifications, or both at any time without notice. The information furnished by Phaselink is believed to be accurate and reliable. However, PhaseLink makes no guarantee or warranty concerning the accuracy of said information and shall not be responsible for any loss or damage of whatever nature resulting from the use of, or reliance upon this product.

LIFE SUPPORT POLICY: PhaseLink's products are not authorized for use as critical components in life support devices or systems without the express written approval of the President of PhaseLink Corporation.

Solder reflow profile available at www.phaselink.com/QA/solderingGreen.pdf