

Low Skew Output Buffer

FEATURES

- Frequency range 75 ~ 180MHz.
- Internal phase locked loop will allow spread spectrum modulation on reference clock to pass to the outputs (up to 100kHz SST modulation).
- Zero input - output delay.
- Less than 700 ps device - device skew.
- Less than 250 ps skew between outputs.
- Less than 150 ps cycle - cycle jitter.
- Output Enable function tri-state outputs.
- 3.3V operation.
- Available in 8-Pin 150mil SOIC **GREEN** package.

PIN CONFIGURATION

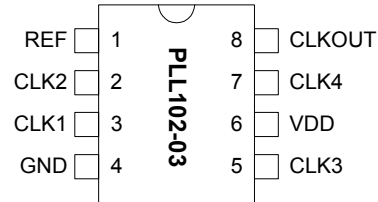

Remark

If REF clock is stopped for more than 10us after it has already been provided to the chip, and after power-up, the output clocks will disappear. In that instance, a full power-up reset is required in order to reactivate the output clocks.

DESCRIPTION

The PLL102-03 is a high performance, low skew, low jitter zero delay buffer designed to distribute high speed clocks and is available in an 8-pin SOIC package. It has four outputs that are synchronized with the input. The synchronization is established via CLKOUT feed back to the input of the PLL. Since the skew between the input and output is less than ± 350 ps, the device acts as a zero delay buffer.

BLOCK DIAGRAM

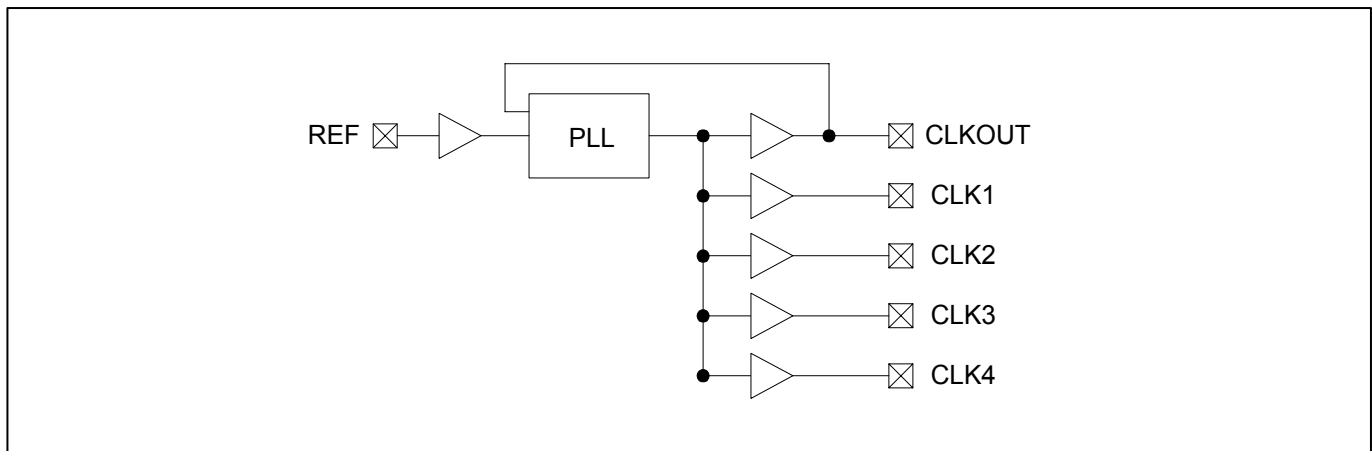

Low Skew Output Buffer

PIN DESCRIPTIONS

Name	Number	Type	Description
REF ¹	1	I	Input reference frequency. Spread spectrum modulation on this signal will be passed to the output (up to 100kHz SST modulation).
CLK2 ²	2	O	Buffered clock output.
CLK1 ²	3	O	Buffered clock output.
GND	4	P	Ground.
CLK3 ²	5	O	Buffered clock output.
VDD	6	P	3.3V Power Supply.
CLK4 ²	7	O	Buffered clock output.
CLKOUT ²	8	O	Buffered clock output. Internal feed back on this pin.

Notes: 1: Weak pull-down. 2: Weak pull-down on all outputs.

ELECTRICAL SPECIFICATIONS

1. Absolute Maximum Ratings

PARAMETERS	SYMBOL	MIN.	MAX.	UNITS
Supply Voltage	V _{DD}		4.6	V
Input Voltage, dc	V _I	-0.5	V _{DD} +0.5	V
Output Voltage, dc	V _O	-0.5	V _{DD} +0.5	V
Storage Temperature	T _S	-65	150	°C
Ambient Operating Temperature*	T _A	-40	85	°C
Junction Temperature	T _J		125	°C
Lead Temperature (soldering, 10s)			260	°C
ESD Protection, Human Body Model			2	kV

Exposure of the device under conditions beyond the limits specified by Maximum Ratings for extended periods may cause permanent damage to the device and affect product reliability. These conditions represent a stress rating only, and functional operations of the device at these or any other conditions above the operational limits noted in this specification is not implied.

* Note: Operating Temperature is guaranteed by design for all parts (COMMERCIAL and INDUSTRIAL), but tested for COMMERCIAL grade only.

2. Electrical Characteristics

PARAMETERS	SYMBOL	CONDITIONS	MIN.	TYP.	MAX.	UNITS
Supply Voltage	V _{DD}		2.97		3.63	V
Input Low Voltage	V _{IL}				0.8	V
Input High Voltage	V _{IH}		2.0			V
Input Low Current	I _{IL}	V _{IN} = 0V		19	50.0	μA
Input High Current	I _{IH}	V _{IN} = V _{DD}		0.10	100.0	μA
Output Low Voltage	V _{OL}	I _{OL} = 50mA		0.25	0.4	V
Output High Voltage	V _{OH}	I _{OH} = 50mA	2.4	2.9		V
Power Down Supply Current	I _{DD}	REF = 0MHz		0.3	50.0	μA
Supply Current	I _{DD}	Unloaded outputs at 133MHz, SEL inputs at V _{DD} or GND		35	45	mA

3. Switching Characteristics

PARAMETERS	SYMBOL	DESCRIPTION	MIN.	TYP.	MAX.	UNITS
Output Frequency	t1		75		180	MHz
Duty Cycle (t2 ÷ t1)	Dt1	Measured at 1.4V, C _L =30pF	40.0	50.0	60.0	%
Duty Cycle (t2 ÷ t1)	Dt2	Measured at 1.4V	45.0	50.0	55.0	%
Rise Time	T _r	Measured between 0.8V and 2.0V, C _L =30pF		1.2	1.5	ns
Fall Time	T _f	Measured between 2.0V and 0.8V, C _L =30pF		1.2	1.5	ns
Output to Output Skew	T _{skew}	All outputs equally loaded, C _L =20pF			250	ps
Delay, REF Rising Edge to CLKOUT Rising Edge	T _{delay}	Measured at 1.4V		0	±350	ps
Device to Device Skew	T _{dsk-dsk}	Measured at V _{DD} /2 on the CLKOUT pins of devices		0	700	ps
Cycle to Cycle Jitter	T _{cyc-cyc}	Measured at 133MHz, loaded outputs			150	ps
PLL Lock Time	T _{lock}	Stable power supply, valid clock presented on REF pin			1.0	ms
Jitter; Absolute Jitter	T _{jabs}	At 10,000 cycles, C _L =30pF		70	100	ps
Jitter; 1-sigma	T _{j1-s}	At 10,000 cycles, C _L =30pF		10	20	ps

SWITCHING WAVEFORMS

Duty Cycle Timing

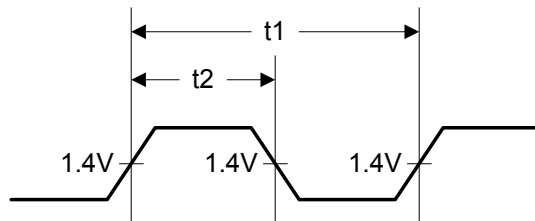

Output - Output Skew

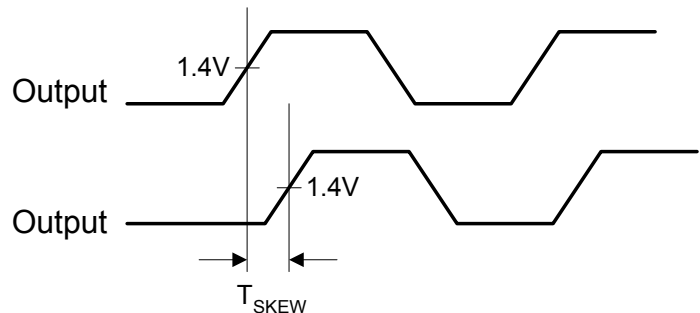

SWITCHING WAVE FORMS

All Outputs Rise/Fall Time

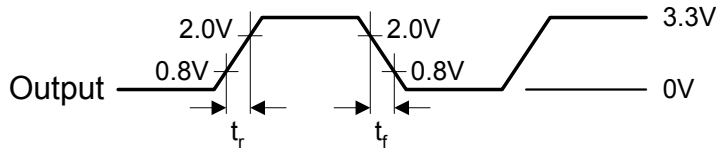

Input to Output Propagation Delay

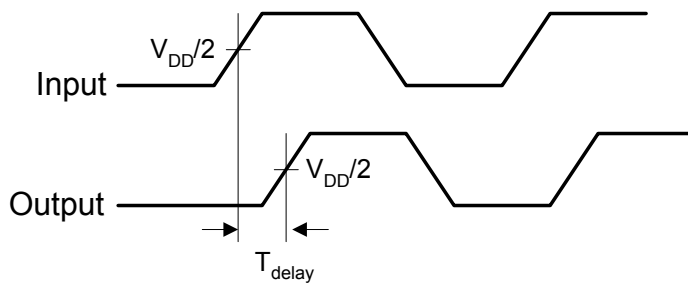

Device to Device Skew

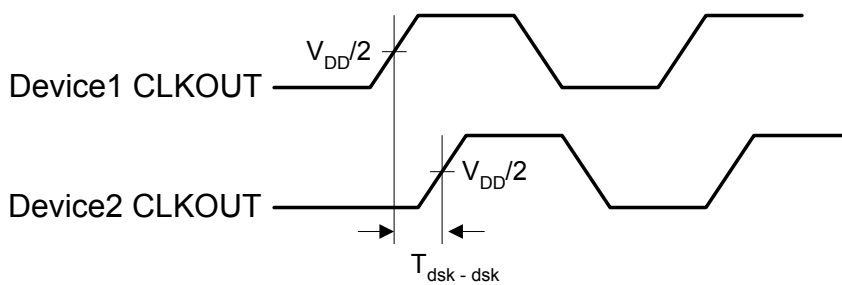

Low Skew Output Buffer

Output-Output Skew

The skew between CLKOUT and the CLK(1-4) outputs is not dynamically adjusted by the PLL. Since CLKOUT is one of the inputs to the PLL, zero phase difference is maintained from REF to CLKOUT. If all outputs are equally loaded, zero phase difference will be maintained from REF to all outputs.

If applications requiring zero output-output skew, all the outputs must be equally loaded.

If the CLK(1-4) outputs are less loaded than CLKOUT, CLK(1-4) outputs will lead it; if the CLK(0-4) is more loaded than CLKOUT, CLK(1-4) will lag the CLKOUT.

Since the CLKOUT and the CLK(1-4) outputs are identical, they all start at the same time, but difference loads cause them to have different rise times and different times crossing the measurement thresholds.

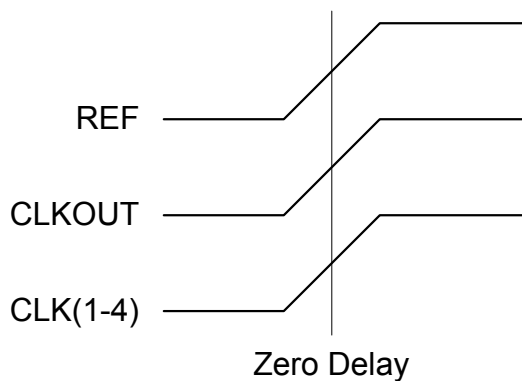

REF input and all outputs loaded equally

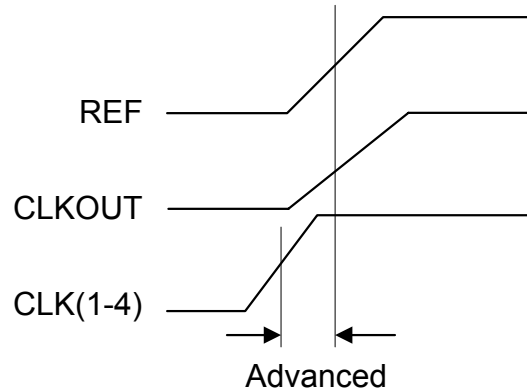

REF input and CLK(1-4) outputs loaded equally, with CLK(1-4) less loaded than CLKOUT.

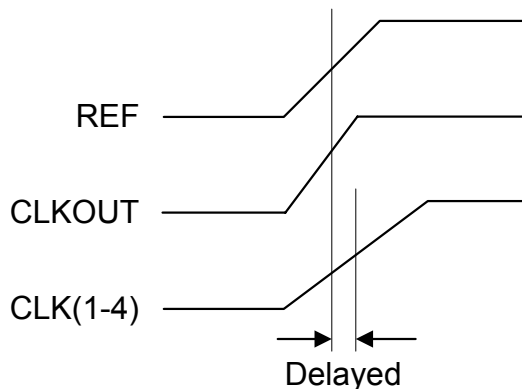

REF input and CLK(1-4) outputs loaded equally, with CLK(1-4) more loaded than CLKOUT.

Low Skew Output Buffer

PACKAGE INFORMATION

8 PIN Narrow SOIC (mm)

Symbol	SOIC	
	Min.	Max.
A	1.55	1.73
A1	0.15	0.18
B	0.35	0.49
C	0.19	0.25
D	4.80	4.98
E	3.81	3.99
H	5.84	6.20
L	0.41	0.89
e	1.27 BSC	

ORDERING INFORMATION

For part ordering, please contact our Sales Department:

47745 Fremont Blvd., Fremont, CA 94538, USA

Tel: (510) 492-0990 Fax: (510) 492-0991

PART NUMBER

The order number for this device is a combination of the following:
Device number, Package type and Operating temperature range

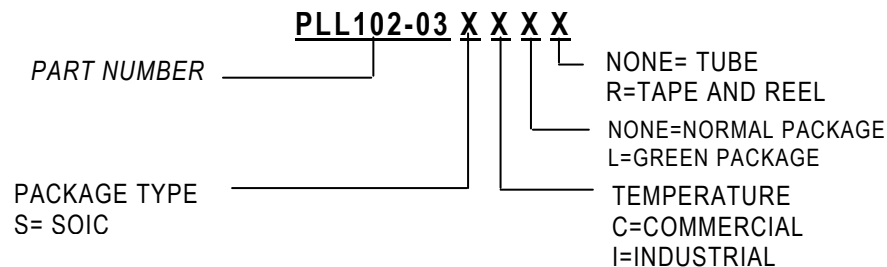

Part / Order Number	Marking	Package Option
PLL102-03SC	P102-03SC	8-Pin SOIC (Tube)
PLL102-03SC-R	P102-03SC	8-Pin SOIC (Tape and Reel)
PLL102-03SCL	P102-03SCL	8-Pin SOIC GREEN (Tube)
PLL102-03SCL-R	P102-03SCL	8-Pin SOIC GREEN (Tape and Reel)

PhaseLink Corporation, reserves the right to make changes in its products or specifications, or both at any time without notice. The information furnished by Phaselink is believed to be accurate and reliable. However, PhaseLink makes no guarantee or warranty concerning the accuracy of said information and shall not be responsible for any loss or damage of whatever nature resulting from the use of, or reliance upon this product.

LIFE SUPPORT POLICY: PhaseLink's products are not authorized for use as critical components in life support devices or systems without the express written approval of the President of PhaseLink Corporation.