

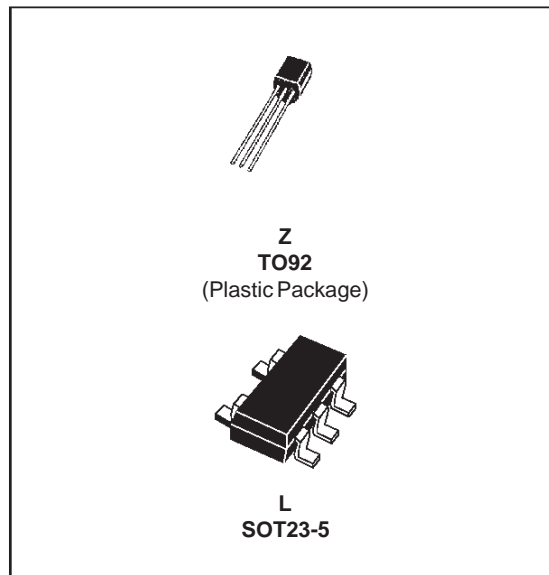

TS431

LOW VOLTAGE ADJUSTABLE SHUNT REFERENCE

- LOW VOLTAGE OPERATION : 1.24 TO 6V
- 2% and 1% VOLTAGE PRECISION
- WIDE RANGE CATHODE CURRENT : 25 μ A TO 30mA
- LOW OUTPUT IMPEDANCE : 0.25W
- HIGH STABILITY WHILE OPERATING WITH CAPACITIVE LOAD
- ESD PROTECTION :
 - 5kV (Human Body Model)
 - 200V (Machine Model)
- OPTIMIZED FOR HIGH TEMPERATURES



DESCRIPTION

The TS431 is a three terminals programmable shunt Voltage Reference optimized for high temperatures. However, it can operate from -40°C up to $+125^{\circ}\text{C}$. The output voltage is set by two external resistors to any value between 1.24 and 6V. When driving an optocoupler, the TS431 is particularly interesting to regulate 3.3V switching power supplies.

ORDER CODES

Part Number	Temperature Range	Package		SOT23 Marking
		Z	L	
TS431I	-40°C , $+125^{\circ}\text{C}$	•	•	L272
TS431AI	-40°C , $+125^{\circ}\text{C}$	•	•	L271

PIN CONNECTIONS (top view)

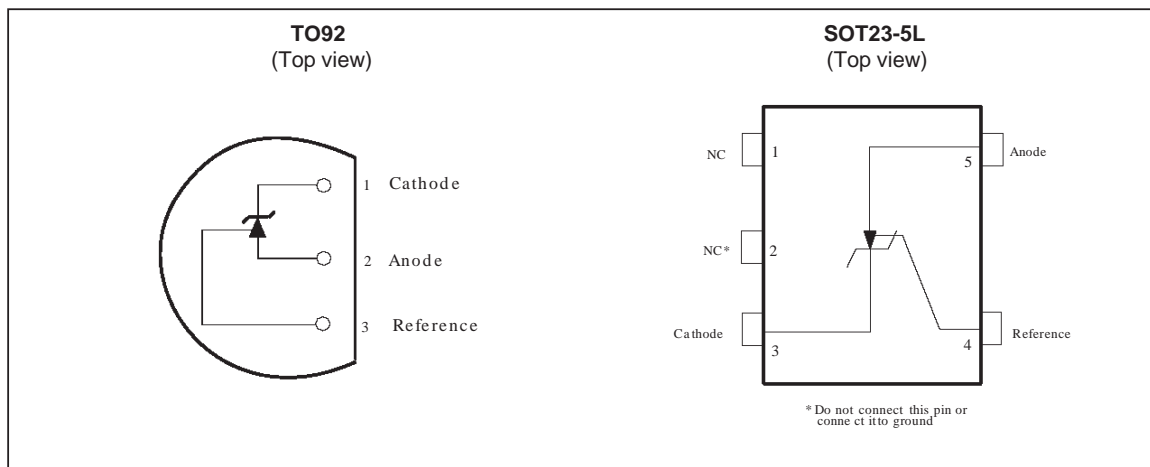

TS431

ABSOLUTE MAXIMUM RATINGS

Symbol	Parameter	Value	Unit
V_{KA}	Cathode to Anode Voltage	10	V
I_K	Continuous Cathode Current Range	-20 to +40	mA
I_{ref}	Reference Input Current Range	-0.05 to +3	mA
P_d	Power dissipation, TO92 package @ $T_{amb.} = 25^{\circ}C$ Power dissipation, SO23-5 package @ $T_{amb.} = 25^{\circ}C$	625 500	mW
T_{oper}	Operating Free-air Temperature Range	-40 to +125	$^{\circ}C$
T_{stg}	Storage Temperature Range	-65 to +150	$^{\circ}C$

OPERATING CONDITIONS

Symbol	Parameter	Value	Unit
V_{KA}	Cathode to Anode Voltage	V_{ref} to 6	V
I_K	Cathode Current	0.025 to 30	mA

TS431

ELECTRICAL CHARACTERISTICS $T_{amb} = 25^{\circ}C$ (unless otherwise specified)

Symbol	Parameter	Test Conditions	Min.	Typ.	Max.	Unit
V_{ref}	Output Voltage $V_{KA} = V_{ref}$ @ $I_K = 100\mu A$	$T_{amb} = 25^{\circ}C$	1.215	1.240	1.265	V
ΔV_{ref}	Output Voltage Change - note 1 $I_K = 100\mu A$, $V_{KA} = V_{ref}$	$0 < T_{amb} < +70^{\circ}C$ $0 < T_{amb} < +105^{\circ}C$ $0 < T_{amb} < +125^{\circ}C$ $-20 < T_{amb} < +105^{\circ}C$ $-40 < T_{amb} < +85^{\circ}C$ $-40 < T_{amb} < +125^{\circ}C$			15 20 25 30 35 40	mV
$\left \frac{\Delta V_{ref}}{\Delta V_{KA}} \right $	Ratio of Change in Reference Input Voltage to Change in Cathode to Anode Voltage	$I_K = 10mA$ $V_{KA} = 6V$ to V_{ref}			2.7	mV/V
I_{ref}	Reference Input Current	$I_K = 10mA$		30	100	nA
ΔI_{ref}	Reference Input Current Deviation Over Temperature Range	$I_K = 10mA$ $R_1 = 10k\Omega$ $R_2 = \infty$		30	60	nA
I_{min}	Minimum Cathode Current for Regulation	$V_{KA} = V_{ref}$		25	40	μA
I_{off}	Off-State Cathode Current	$V_{KA} = 6V$, $V_{ref} = 0$		0.001	0.1	μA
$ Z_{KA} $	Dynamic Impedance	$V_{KA} = V_{ref}$, $f < 1kHz$ $I_K = 0.1$ to $15mA$		0.25	0.4	Ω

Notes : 1. ΔV_{ref} is defined as the difference between the maximum and minimum values obtained over the full temperature range.

$$\Delta V_{ref} = V_{ref \max.} - V_{ref \min.}$$

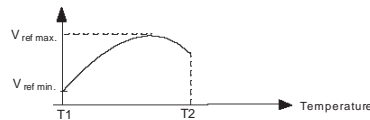

TS431A

ELECTRICAL CHARACTERISTICS $T_{amb} = 25^{\circ}\text{C}$ (unless otherwise specified)

Symbol	Parameter	Test Conditions	Min.	Typ.	Max.	Unit
V_{ref}	Output Voltage $V_{KA} = V_{ref}$ @ $I_K = 100\mu\text{A}$	$T_{amb} = 25^{\circ}\text{C}$	1.228	1.240	1.252	V
ΔV_{ref}	Output Voltage Change - note 1 $I_K = 100\mu\text{A}$, $V_{KA} = V_{ref}$	$0 < T_{amb} < +70^{\circ}\text{C}$ $0 < T_{amb} < +105^{\circ}\text{C}$ $0 < T_{amb} < +125^{\circ}\text{C}$ $-20 < T_{amb} < +105^{\circ}\text{C}$ $-40 < T_{amb} < +85^{\circ}\text{C}$ $-40 < T_{amb} < +125^{\circ}\text{C}$			15 20 25 30 35 40	mV
$\left \frac{\Delta V_{ref}}{\Delta V_{KA}} \right $	Ratio of Change in Reference Input Voltage to Change in Cathode to Anode Voltage	$I_K = 10\text{mA}$ $V_{KA} = 6\text{V to } V_{ref}$			2.7	mV/V
I_{ref}	Reference Input Current	$I_K = 10\text{mA}$		30	100	nA
ΔI_{ref}	Reference Input Current Deviation Over Temperature Range	$I_K = 10\text{mA}$ $R_1 = 10\text{k}\Omega$ $R_2 = \infty$		30	60	nA
I_{min}	Minimum Cathode Current for Regulation	$V_{KA} = V_{ref}$		25	40	μA
I_{off}	Off-State Cathode Current	$V_{KA} = 6\text{V}$, $V_{ref} = 0$		0.001	0.1	μA
$ Z_{KA} $	Dynamic Impedance	$V_{KA} = V_{ref}$, $f < 1\text{kHz}$ $I_K = 0.1 \text{ to } 15\text{mA}$		0.25	0.4	Ω

Notes : 1. ΔV_{ref} is defined as the difference between the maximum and minimum values obtained over the full temperature range.

$$\Delta V_{ref} = V_{ref \text{ max.}} - V_{ref \text{ min.}}$$

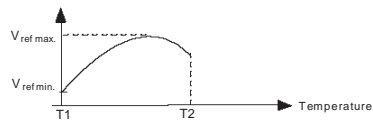

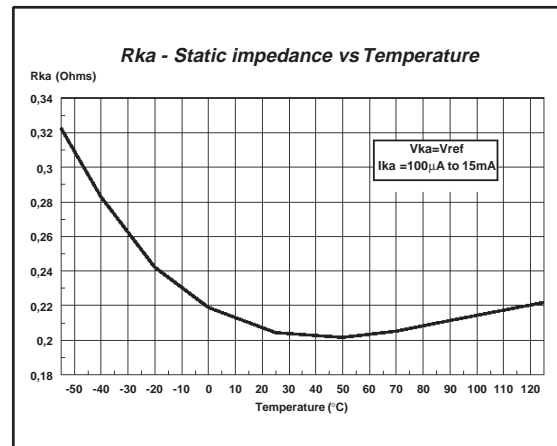
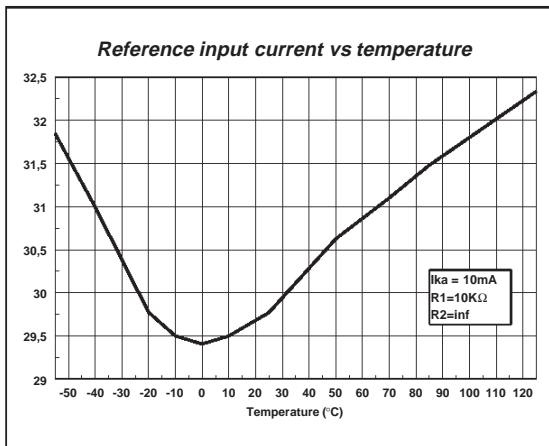
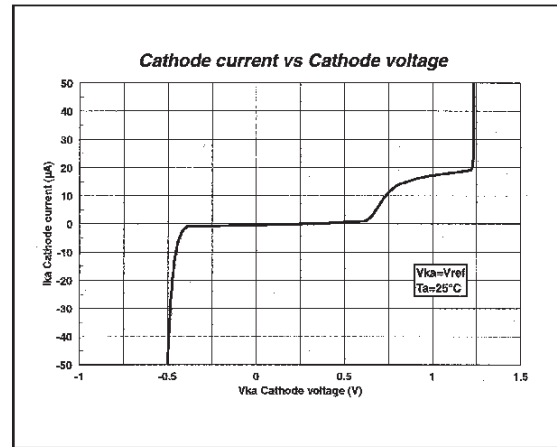
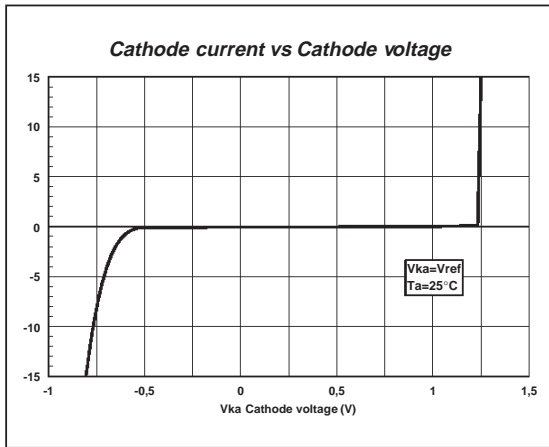
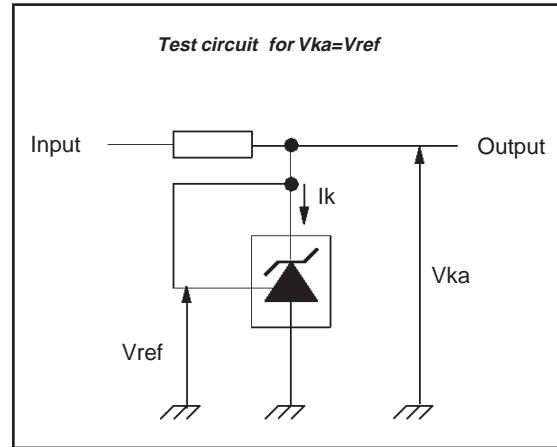
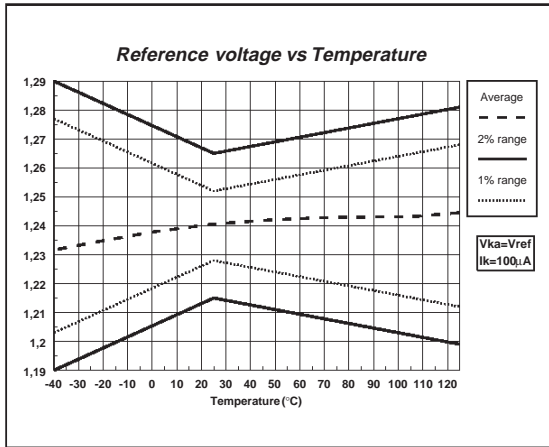

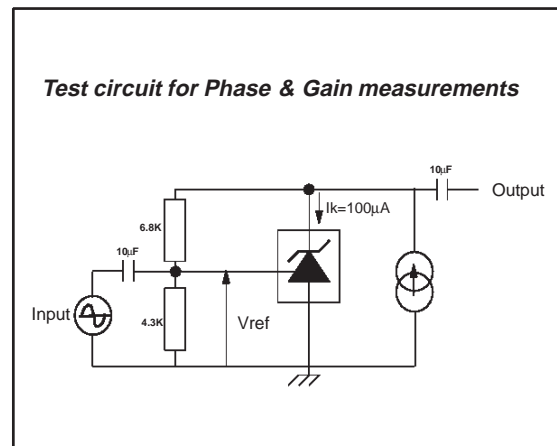
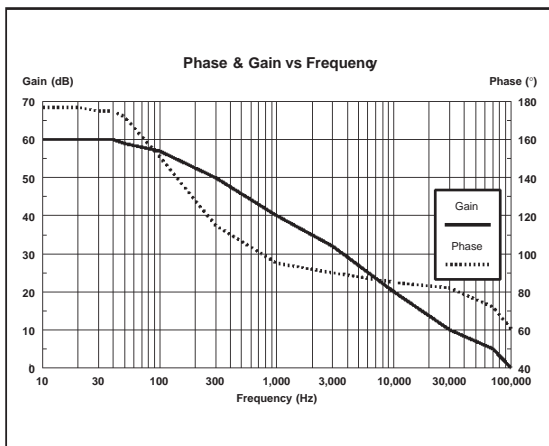
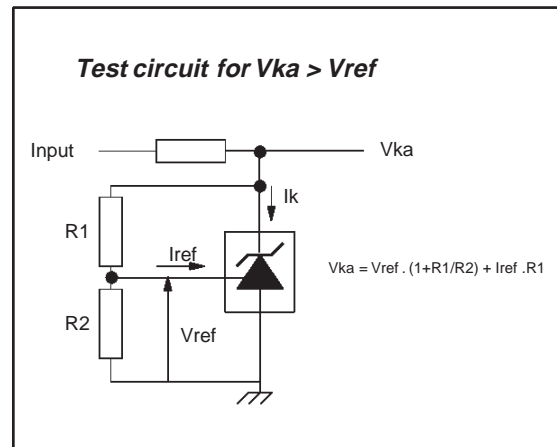
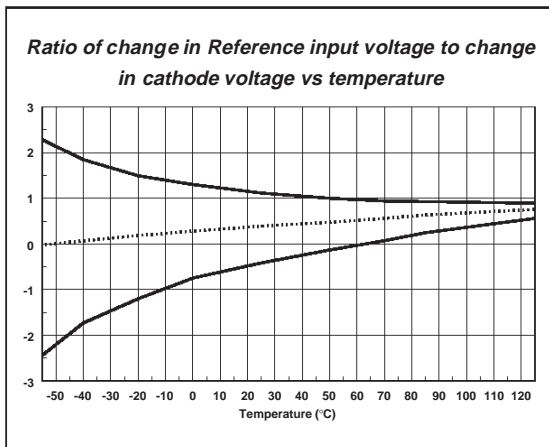
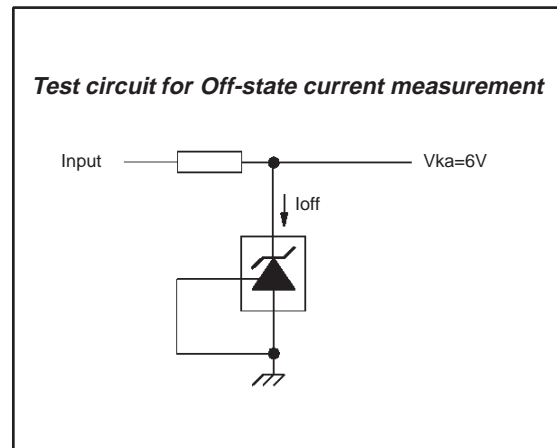
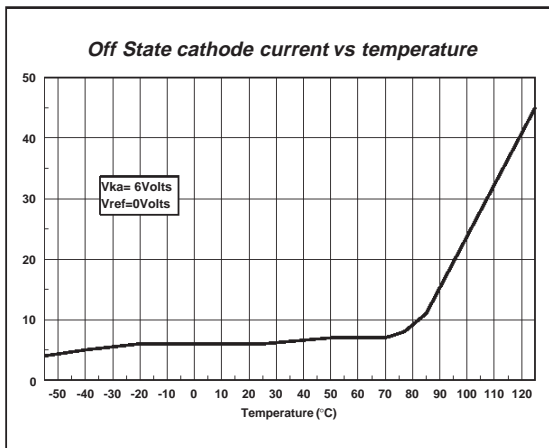

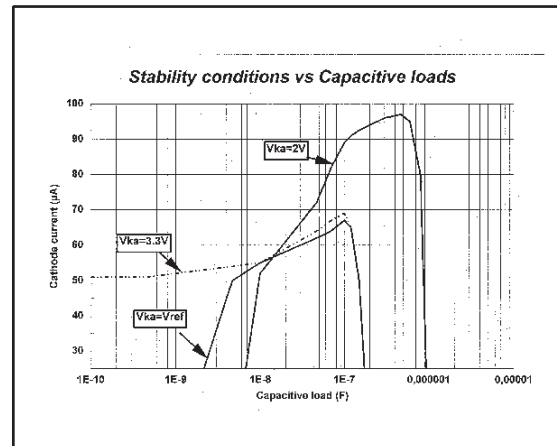
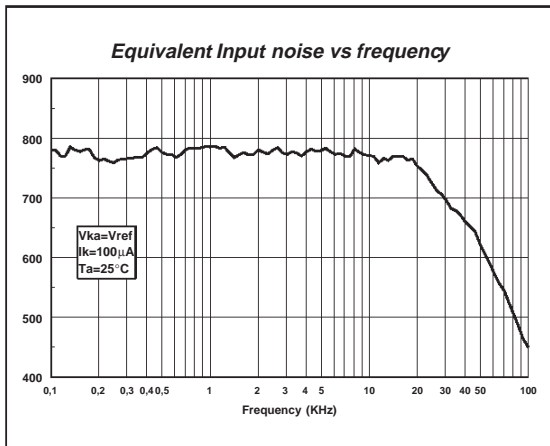
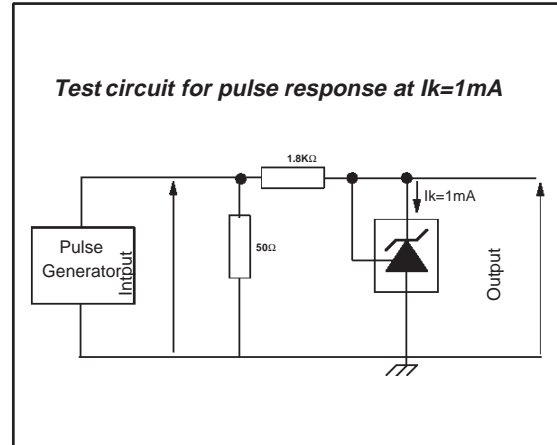
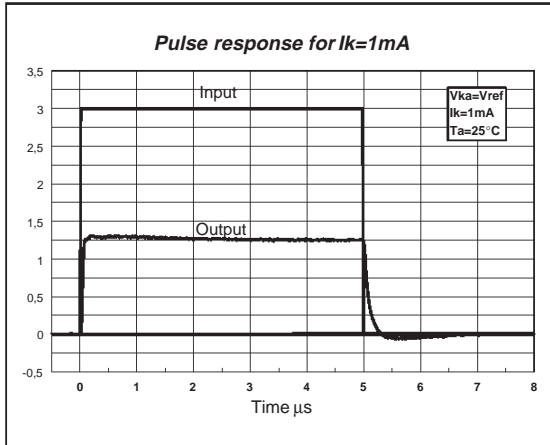
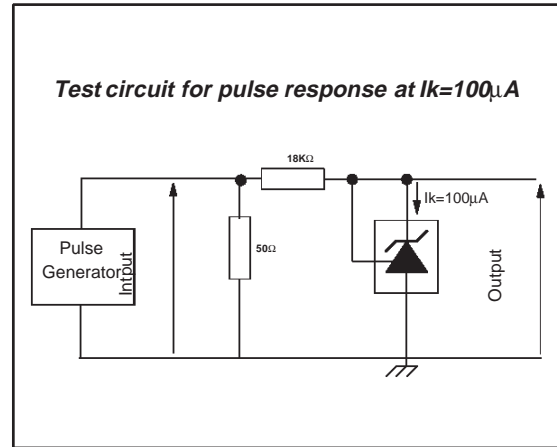
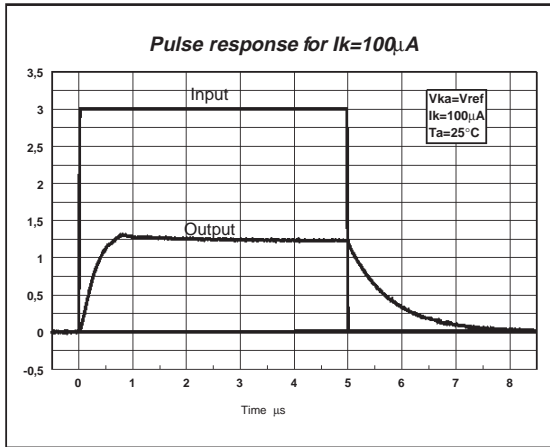

PACKAGE MECHANICAL DATA
SOT23-5L

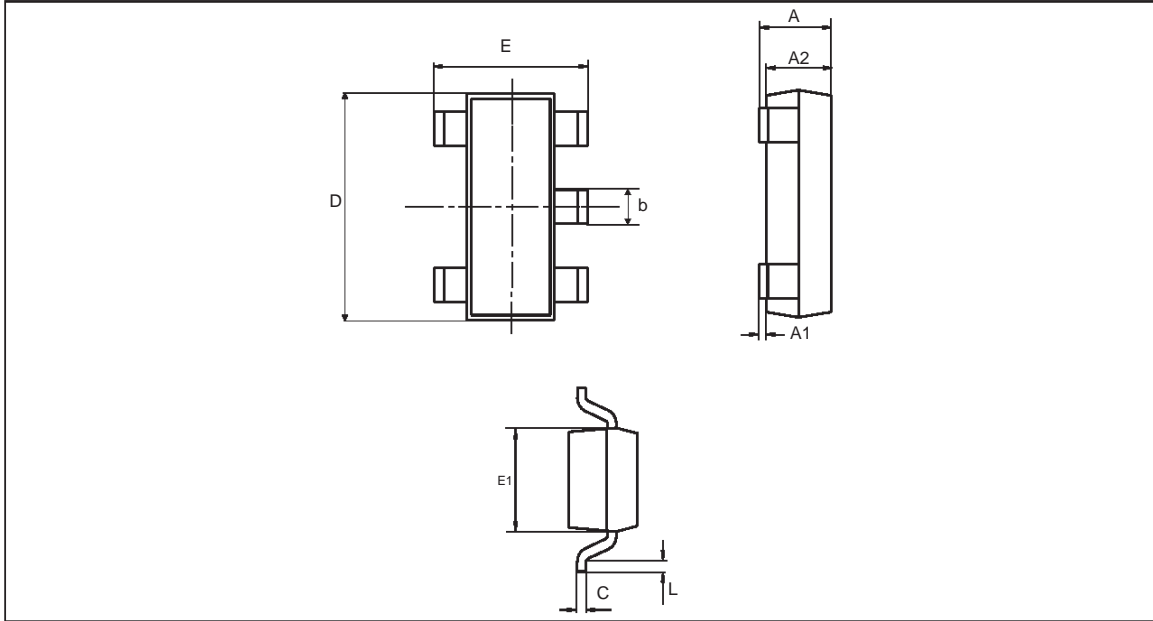

Dimensions	Millimeters		Inches	
	Min.	Max.	Min.	Max.
A	0.90	1.45	0.035	0.057
A1		0.15		0.005
A2	0.90	1.30	0.035	0.051
b	0.35	0.50	0.013	0.019
C	0.09	0.20	0.003	0.007
D	2.80	3.00	0.110	0.118
E	2.60	3.00	0.102	0.118
E1	1.50	1.75	0.059	0.068
L	0.10	0.60	0.003	0.023

PACKAGE MECHANICAL DATA
3 PINS - PLASTIC PACKAGE TO92

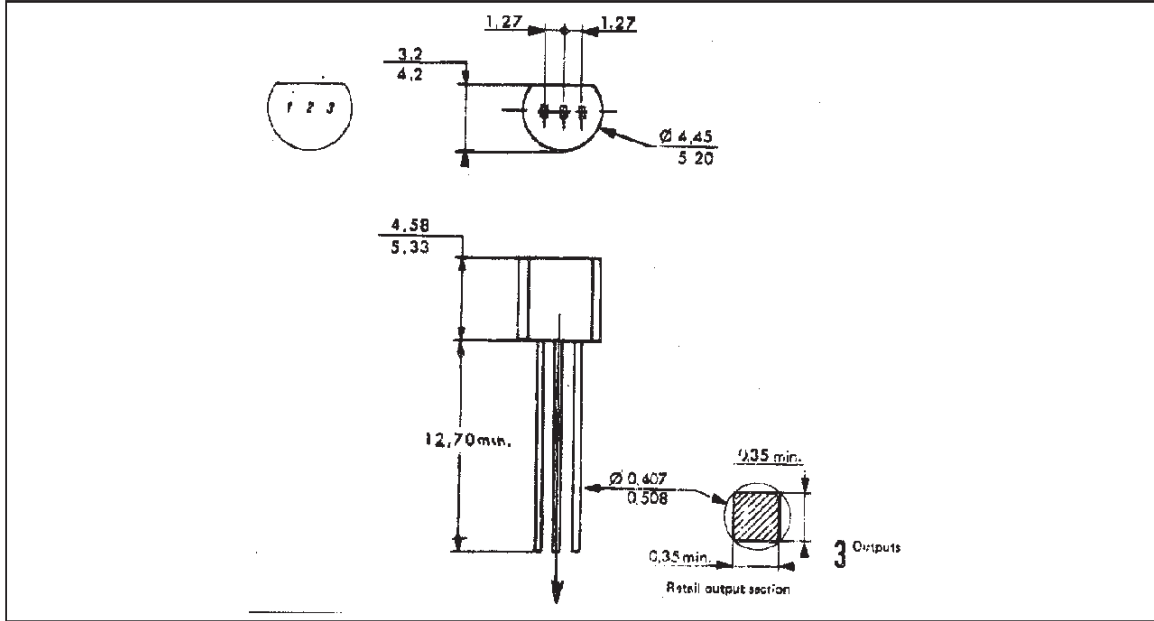

Dimensions	Millimeters			Inches		
	Min.	Typ.	Max.	Min.	Typ.	Max.
L		1.27			0.05	
B	3.2	3.7	4.2	0.126	0.1457	0.1654
O1	4.45	5.00	5.2	0.1752	0.1969	0.2047
C	4.58	5.03	5.33	0.1803	0.198	0.2098
K	12.7			0.5		
O2	0.407	0.5	0.508	0.016	0.0197	0.02
a	0.35			0.0138		

Information furnished is believed to be accurate and reliable. However, STMicroelectronics assumes no responsibility for the consequences of use of such information nor for any infringement of patents or other rights of third parties which may result from its use. No license is granted by implication or otherwise under any patent or patent rights of STMicroelectronics. Specifications mentioned in this publication are subject to change without notice. This publication supersedes and replaces all information previously supplied. STMicroelectronics products are not authorized for use as critical components in life support devices or systems without express written approval of STMicroelectronics.

© The ST logo is a trademark of STMicroelectronics

© 2000 STMicroelectronics – Printed in Italy – All Rights Reserved

STMicroelectronics GROUP OF COMPANIES

Australia - Brazil - China - Finland - France - Germany - Hong Kong - India - Italy - Japan - Malaysia - Malta - Morocco
 Singapore - Spain - Sweden - Switzerland - United Kingdom - U.S.A.

© <http://www.st.com>

