



American Opto Plus LED L513QEC-30D

5mm Dia LED LAMP – Water Clear

- ◆ 5.0mm DIA LED LAMP
- ◆ I.C. COMPATIBLE
- ◆ LOW POWER CONSUMPTION
- ◆ LONG LAMP LIFE

DESCRIPTION

- Round type
- T1-3/4 (5mm) diameter
- Lens color: Water Clear
- With flange
- Solder leads without stand-off

FEATURES

- Emitted color: Red
- Technology: AlGaInP
- Viewing angle: 30°
- Peak wavelength $\lambda_p = 630\text{nm}$

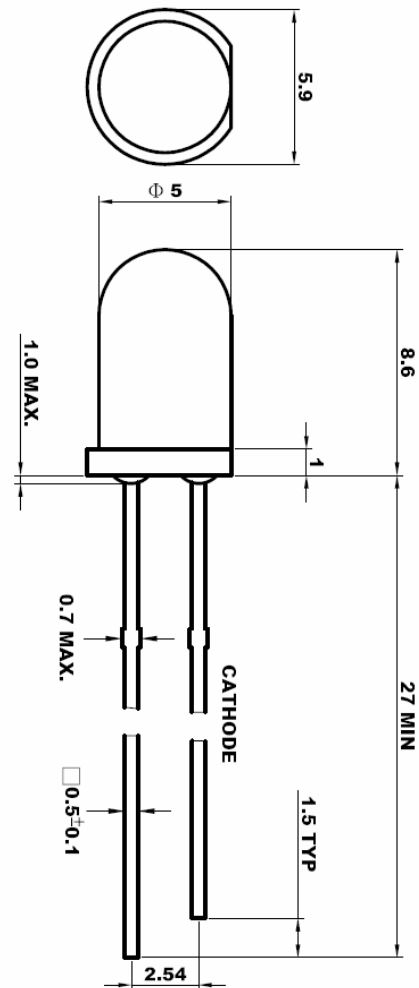

SELECTION GUIDE

Chip Material	Chip Emitted	Lens Color	Viewing Angle
AlGaInP	Red	Water Clear	30°



American Opto Plus LED L513QEC-30D

5mm Dia LED LAMP – Water Clear

- ◆ 5.0mm DIA LED LAMP
- ◆ I.C. COMPATIBLE
- ◆ LOW POWER CONSUMPTION
- ◆ LONG LAMP LIFE

ABSOLUTE MAXIMUM RATINGS

(Ta=25°C)

Parameter	Symbol	Max Rating	Unit
Power Dissipation	P_D	78	mW
Peak Forward Current (1/10 Duty Cycle @1KHz)	I_{PF}	100	mA
Forward Current	I_F	30	mA
Reverse Voltage	V_R	5.0	V
Operating Temperature Range	T_{OPR}	-40~+85	°C
Storage Temperature Range	T_{STG}	-40~+85	°C

Solder temperature 2 mm from body for 3 seconds at 260°C

OPTICAL-ELECTRICAL CHARACTERISTICS

Parameter	Symbol	Test Condition	Min	Typ	Max	Unit
Luminous Intensity	I_V	$I_F = 20mA$	300	450		mcd
Forward Voltage	V_F	$I_F = 20mA$		2.0	2.6	V
Reverse Current	I_R	$V_R = 5V$			10	uA
Viewing Angle	2θ1/2	$I_F = 20mA$		30		deg.
Peak Wavelength	λ_P	$I_F = 20mA$		630		nm
Dominant Wavelength	λ_D	$I_F = 20mA$		620		nm
Spectrum Radiation Bandwidth	$\Delta\lambda$	$I_F = 20mA$		20		nm



American Opto Plus LED L513QEC-30D

5mm Dia LED LAMP – Water Clear

- ◆ 5.0mm DIA LED LAMP
- ◆ I.C. COMPATIBLE
- ◆ LOW POWER CONSUMPTION
- ◆ LONG LAMP LIFE

TYPICAL ELECTRO-OPTICAL CHARACTERISTIC CURVES

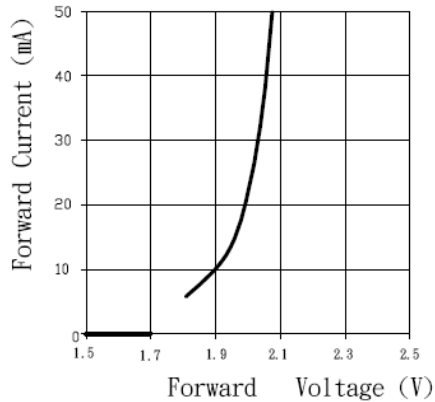

Forward Current Vs.
Forward Voltage

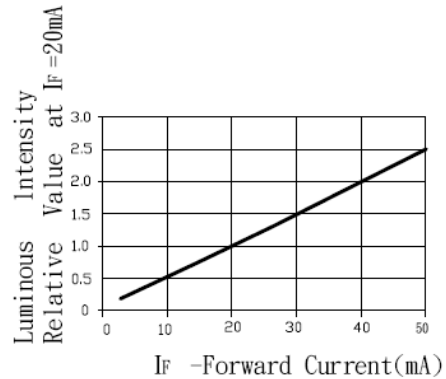

Luminous Intensity Vs.
Forward Current

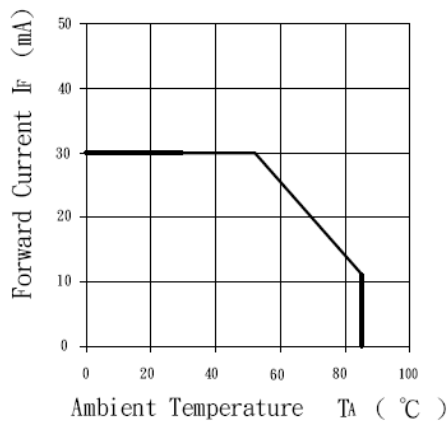

Forward Current
Derating Curve

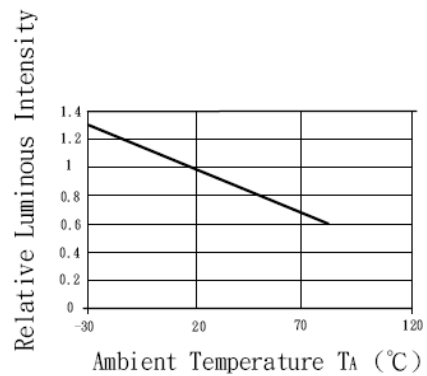

Luminous Intensity Vs.
Ambient Temperature