

## 4 INPUT 1 OUTPUT VIDEO SWITCH with ISOLATION AMP.

### ■ GENERAL DESCRIPTION

The **NJM2526** is a 4-input 1-output video switch with isolation amplifier. Isolation circuit removes the noise of a signal.

The **NJM2526** includes sync chip clamp circuit. It is suitable for the change of the composite signal, synchronized signal of the Car AV equipment

### ■ PACKAGE OUTLINE



**NJM2526V**

### ■ FEATURES

- Operating Voltage 4.5 to 9.0V
- Internal Isolation Amp.
- Internal 4 input 1 output Video Switch
- Syncchip Clamp
- Bipolar Technology
- Package Outline SSOP16

### ■ BLOCK DIAGRAM

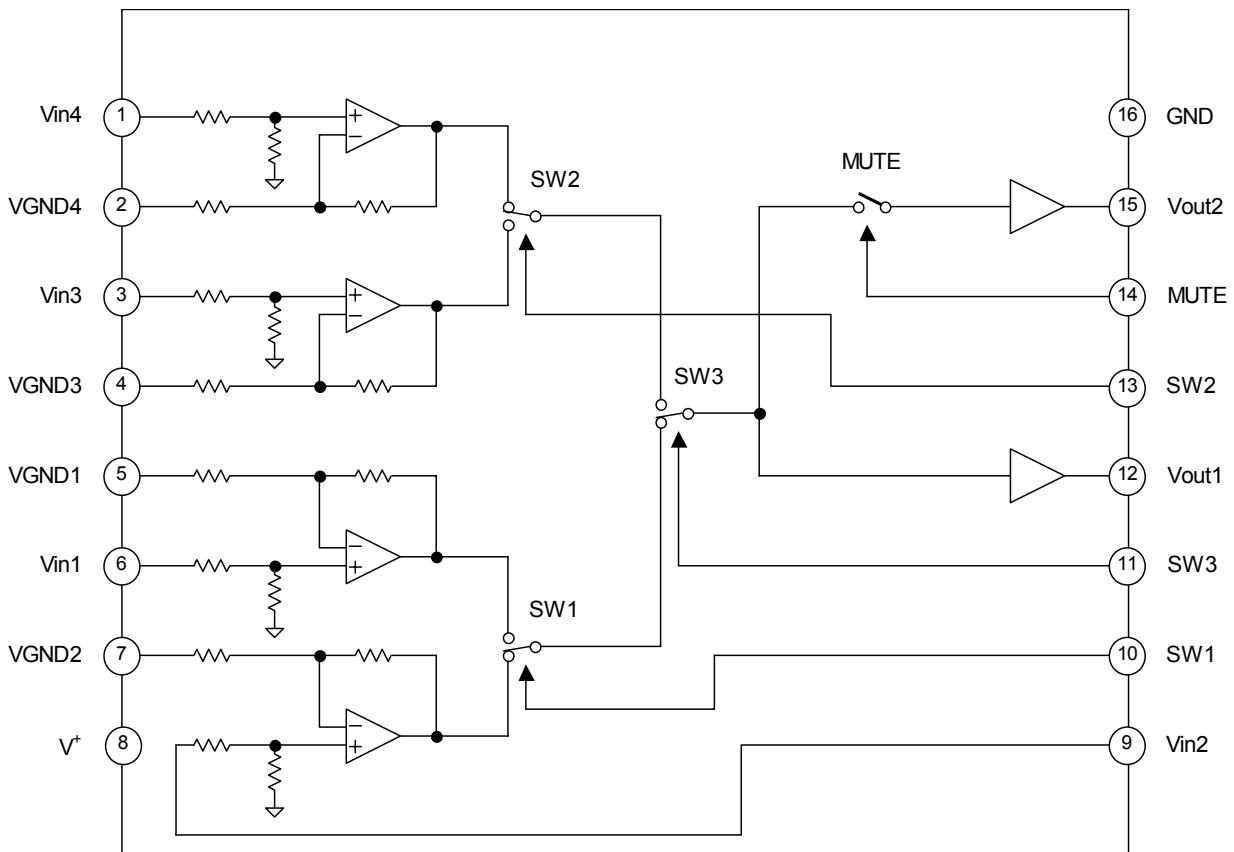

# NJM2526

## ■ ABOSOLUTE MAXIMUM RATINGS (Ta=25°C)

PARAMETER	SYMBOL	RATING	UNIT
Supply Voltage	V <sup>+</sup>	15.0	V
Power Dissipation	P <sub>D</sub>	300	mW
Operating Temperature Range	Topr	-40 to +85	°C
Storage Temperature Range	Tstg	-40 to +125	°C

## ■ RECOMMENDED OPERATING CONDITION (Ta=25°C)

PARAMETER	SYMBOL	TEST CONDITION	MIN.	TYP.	MAX.	UNIT
Operating Voltage	Vopr		4.5	-	9.0	V

## ■ ELECTRICAL CHARACTERISTICS (V<sup>+</sup>=5.0V, Ta=25°C)

PARAMETER	SYMBOL	TEST CONDITION	MIN.	TYP.	MAX.	UNIT
Operating Current	I <sub>CC</sub>	No Signal	-	10	15	mA
Maximum Output Level	Vom1	Vin=100kHz, Sigh-Signal, THD=1%,	2.0	2.2	-	Vp-p
Voltage Gain	Gv	Vin=100kHz, 1.0Vp-p Sign-Signal	-1.0	0	1.0	dB
Frequency Characteristics	Gf	Vin=10MHz / 1MHz, 1.0Vpp Sign-Signal	-1.0	0	1.0	dB
Common Mode Rejection Ratio	CMR	Vin=20kHz, 1.0Vpp	-	-50	-	dB
Crosstalk Between Input	CT-I	Vin=4.43MHz, 1.0Vp-p Sign-Signal	-	-65	-	dB
Differential Gain	DG	Vin=1.0Vp-p 10step Video Signal	-	0.3	-	%
Differential Phase	DP	Vin=1.0Vp-p 10step Video Signal	-	0.4	-	deg
SW Change High Level	VthH		2.0	-	V <sup>+</sup>	V
SW Change Low Level	VthL		0	-	0.6	V

## ■ SW vs. INPUT/OUTPUT

SW1	SW2	SW3	MUTE	Vout1	Vout2
L	X	L	L	Vin1	Vin1
L	X	L	H	Vin1	MUTE
H	X	L	L	Vin2	Vin2
H	X	L	H	Vin2	MUTE
X	L	H	L	Vin3	Vin3
X	L	H	H	Vin3	MUTE
X	H	H	L	Vin4	Vin4
X	H	H	H	Vin4	MUTE

## TEST CIRCUIT 1

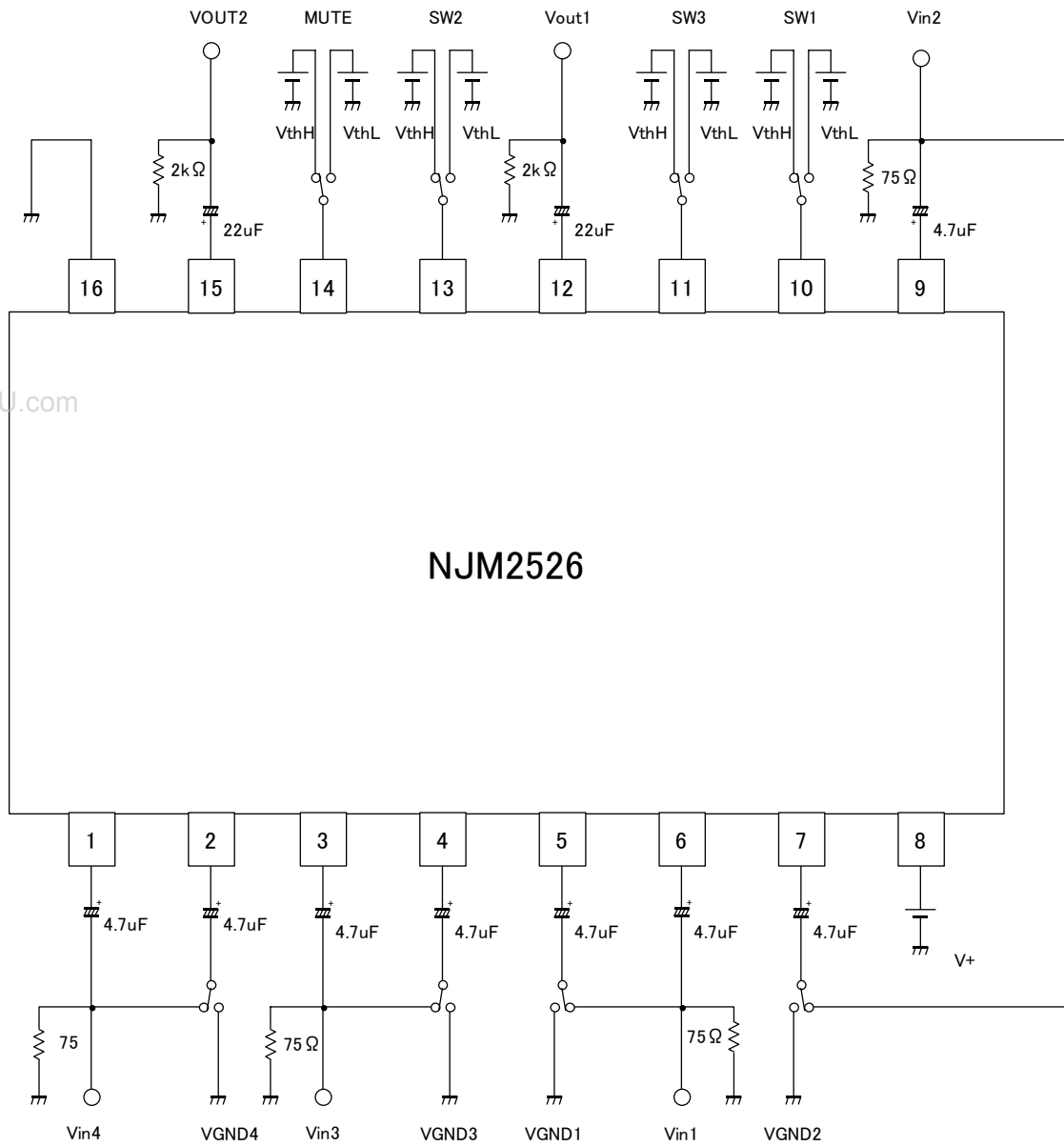

# NJM2526

## TEST CIRCUIT 2 (measure on CMR)

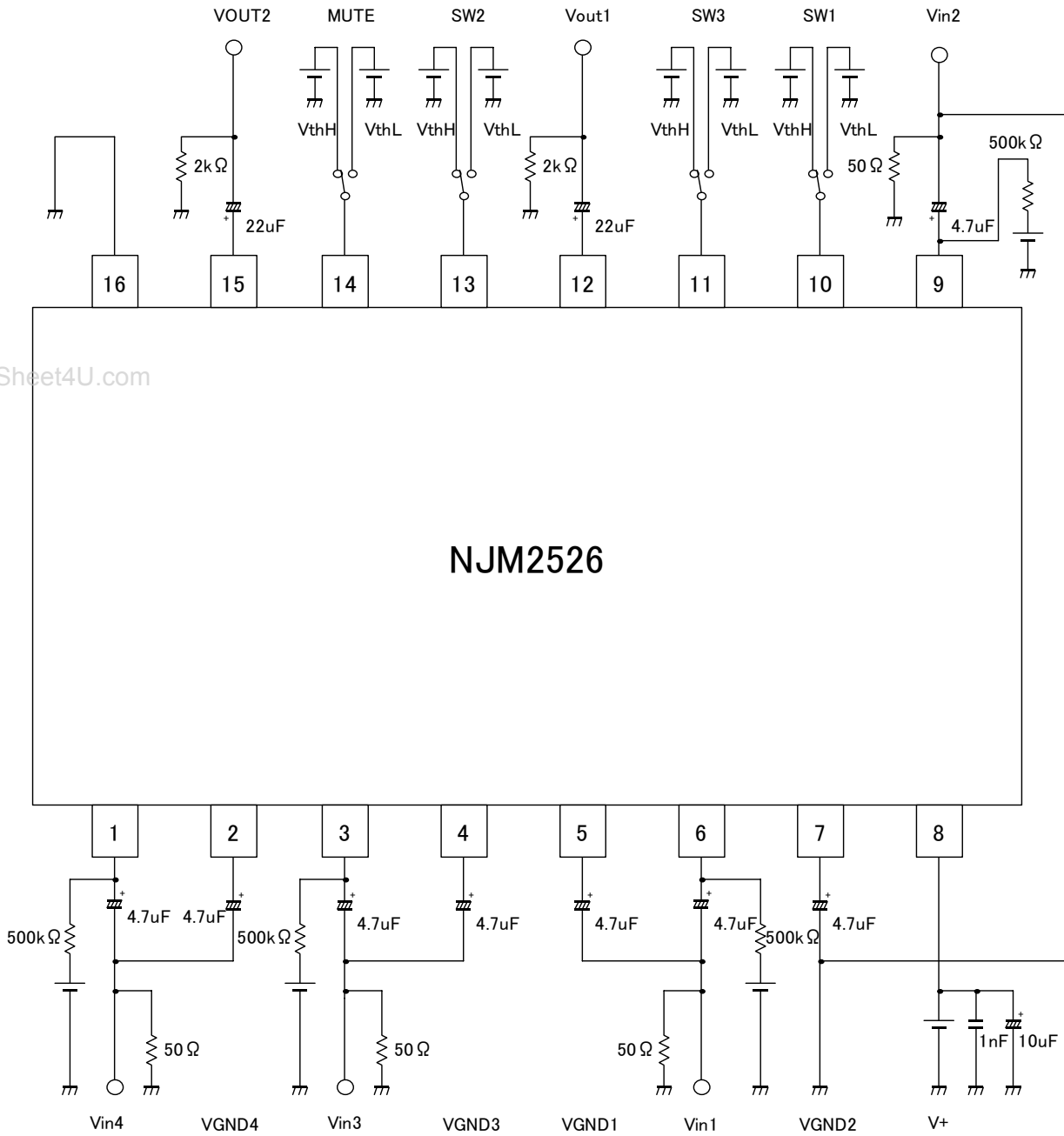

## APPLICATION CIRCUIT

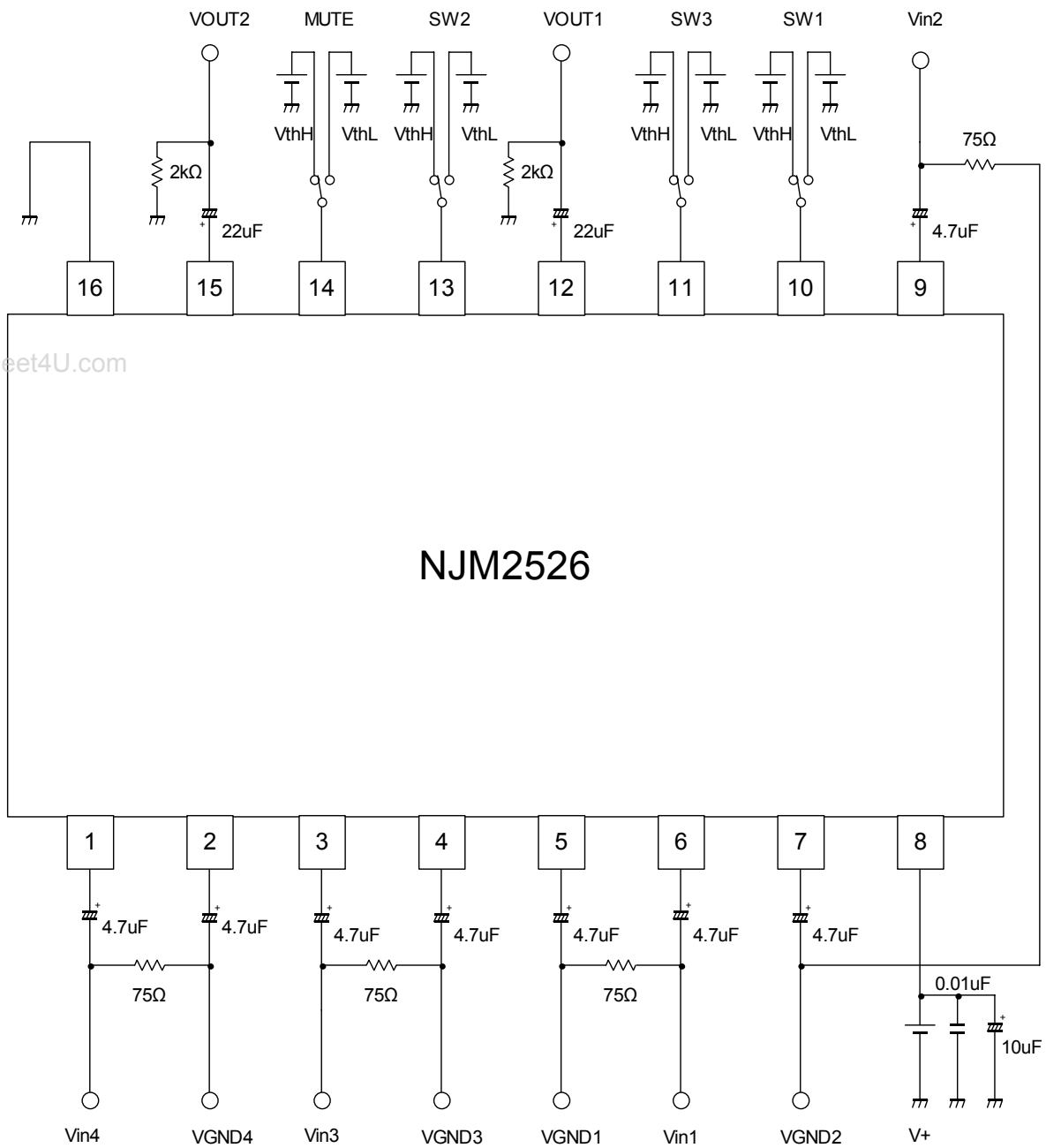

# NJM2526

## ■ EQUIVALENT CIRCUIT

Pin No.	Symbol	Inside Equivalent Circuit	Voltage
1 3 6 9	Vin4 Vin3 Vin1 Vin2		1.64V
2 4 5 7	VGND4 VGND3 VGND1 VGND2		1.63V
8	V <sup>+</sup>		-
10 11 13 14	SW1 SW3 SW2 MUTE		-
12 15	Vout1 Vout2		0.87V
16	GND		-

## TYPICAL CHARACTERISTICS

Voltage Gain vs. Frequency  
( $V_+ = 5V, V_{in} = 1V_{pp}$ )

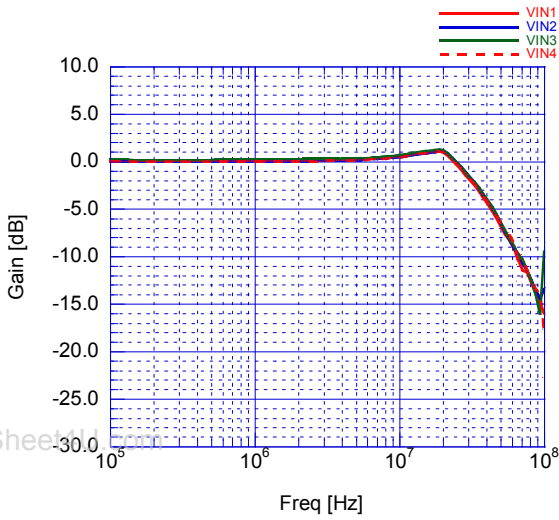

Common Mode Rejection Ratio vs. Frequency  
( $V_+ = 5V, V_{in} = 1V_{pp}$ )

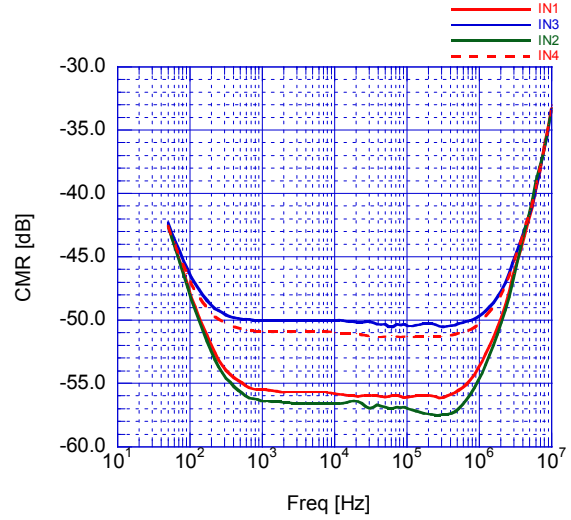

Supply Current vs. Supply Voltage  
(No Signal)

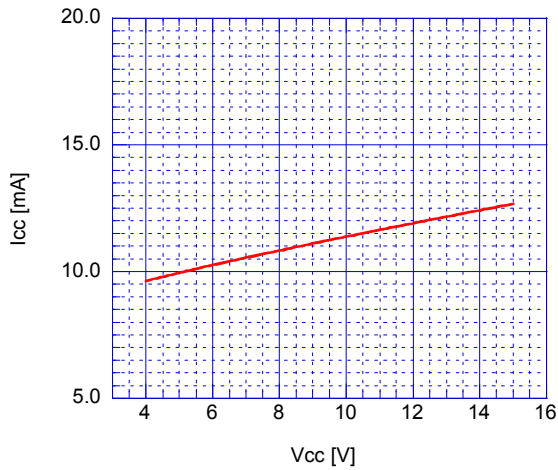

Maximum Output Voltage Swing vs. Supply Voltage  
( $V_{in} = 100kHz$  sine-signal THD=1%)

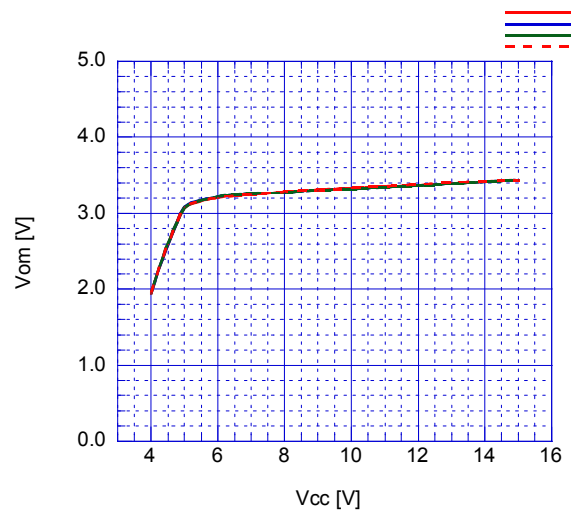

Voltage Gain vs. Supply Voltage  
( $V_{in} = 100kHz$  1Vpp sine-signal)

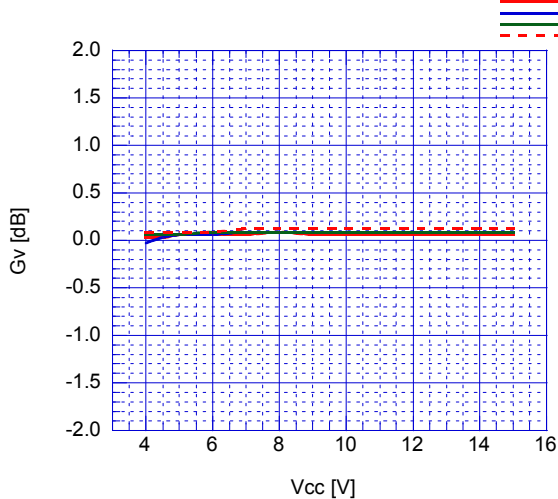

Frequency vs. Supply Voltage  
( $V_{in} = 10MHz/1MHz$  1Vpp sine-signal)

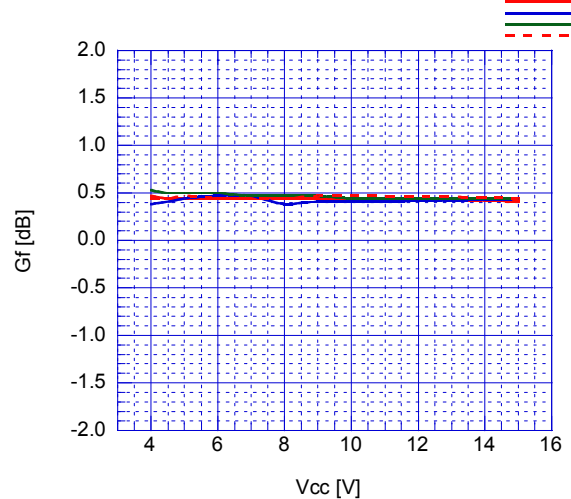

## TYPICAL CHARACTERISTICS

Common Mode Rejection ratio vs. Supply Voltage  
(Vin=20kHz 1Vpp)

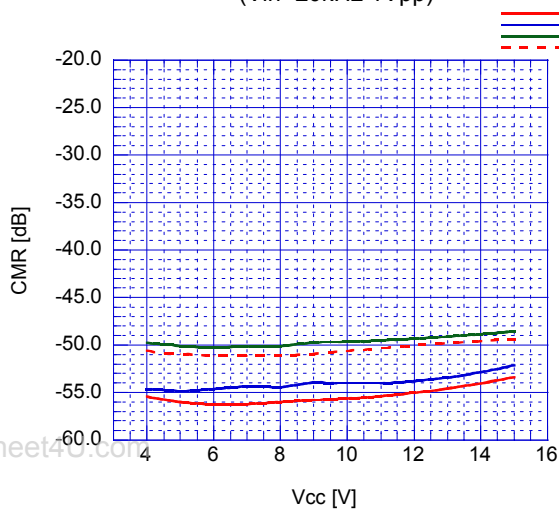

Crosstalk vs. Supply Voltage  
(Vin=4.43MHz 1Vpp Vin1 to Vin2,3,4)

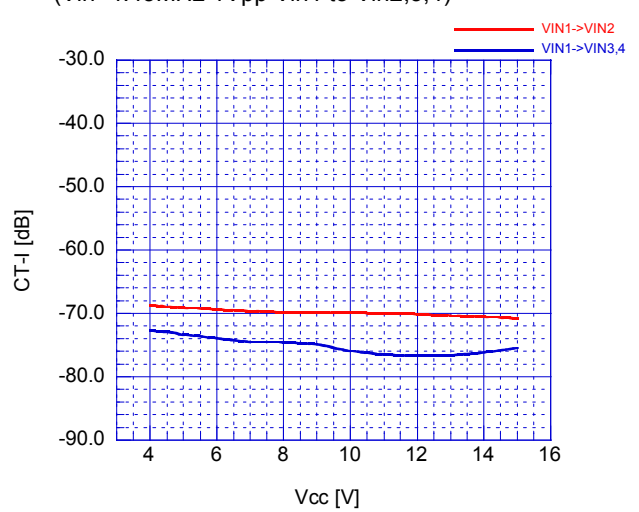

Crosstalk vs. Supply Voltage  
(Vin=4.43MHz 1Vpp, Vin2 to Vin1,3,4)

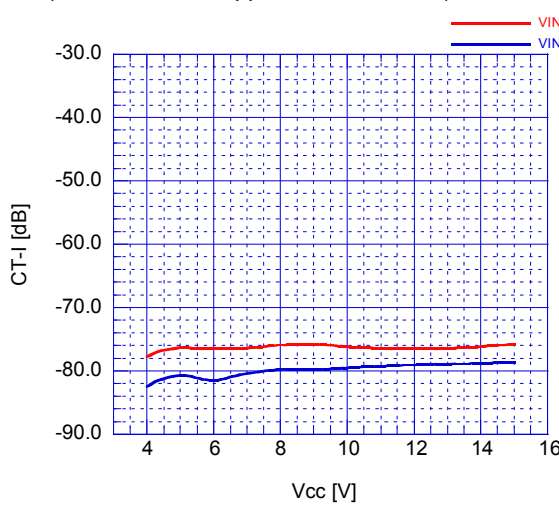

Crosstalk vs. Supply Voltage  
(Vin=4.43MHz 1Vpp, Vin3 to Vin1,2,4)

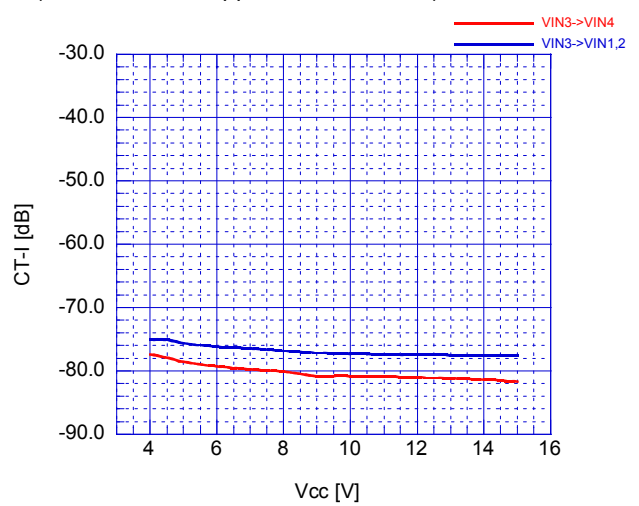

Crosstalk vs. Supply Voltage  
(Vin=4.43MHz 1Vpp Vin4 to Vin1,2,3)

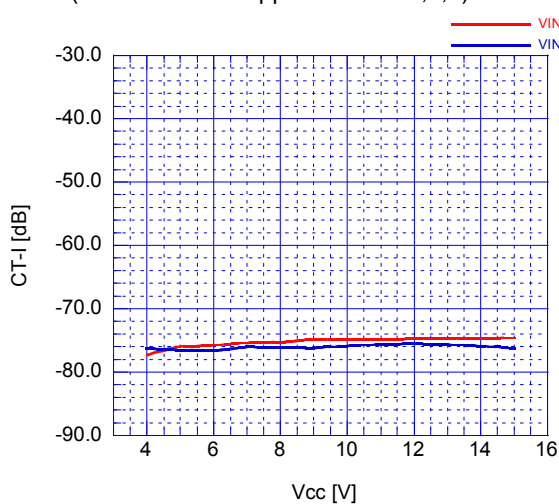

Differential Gain vs. Supply Voltage  
(Viin=1Vpp 10Step signal)

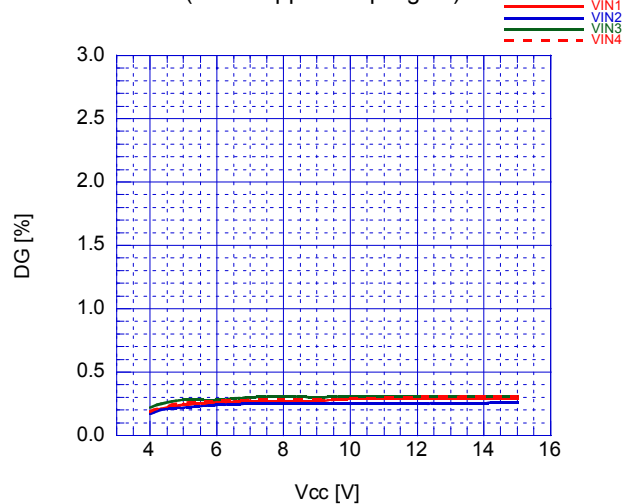



## TYPICAL CHARACTERISTICS

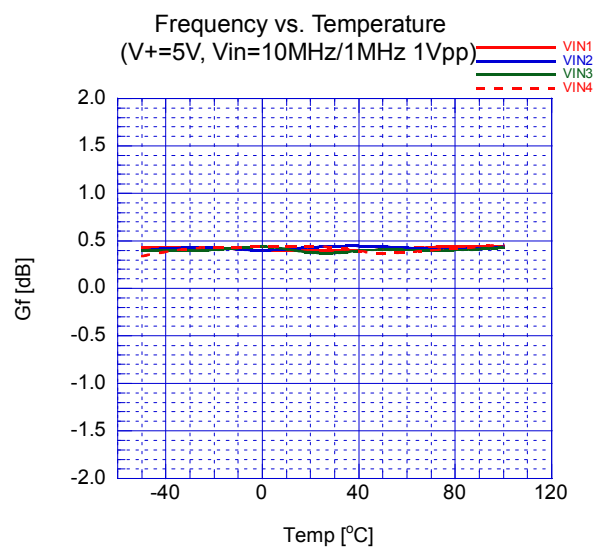
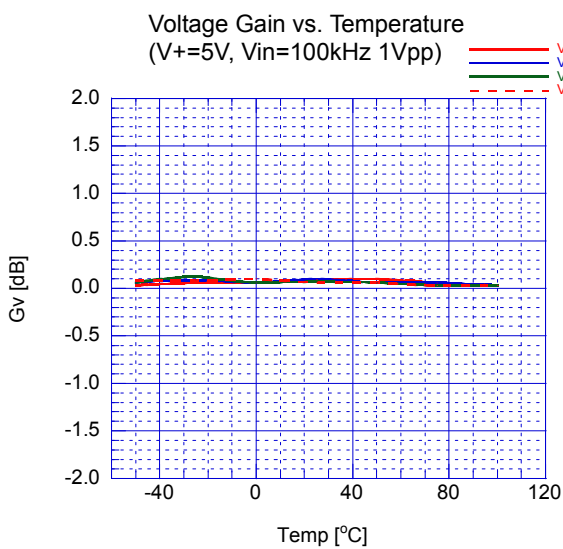
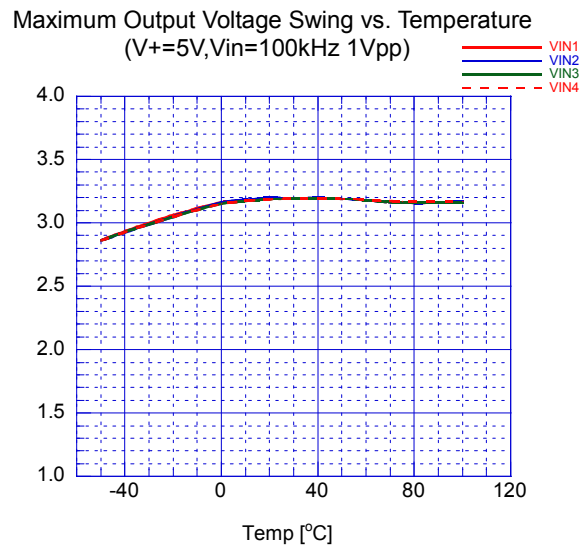
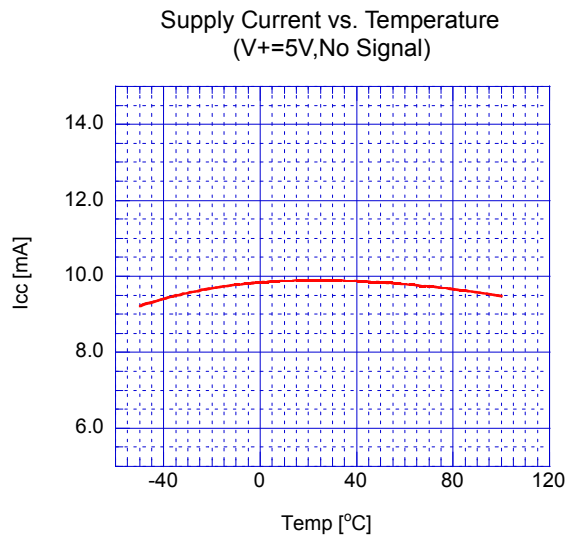
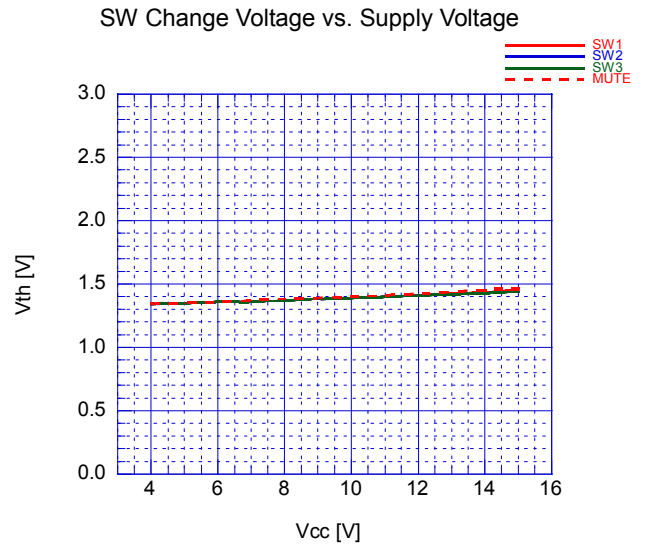
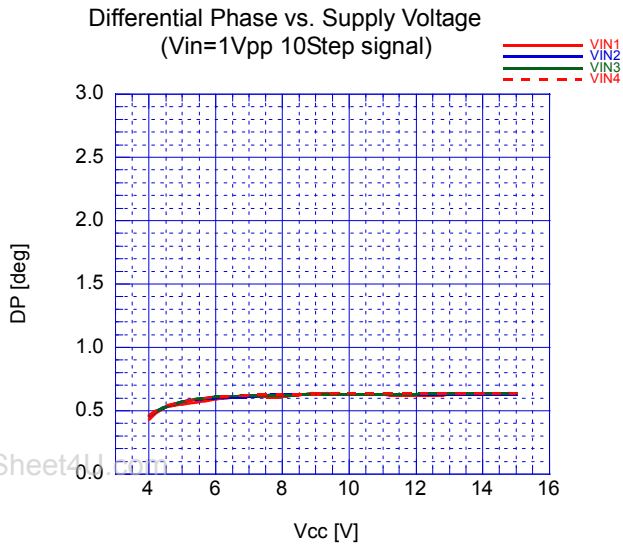

## TYPICAL CHARACTERISTICS

Common Mode Rejection vs. Temperature  
(V+=5V, Vin=20kHz 1Vpp)

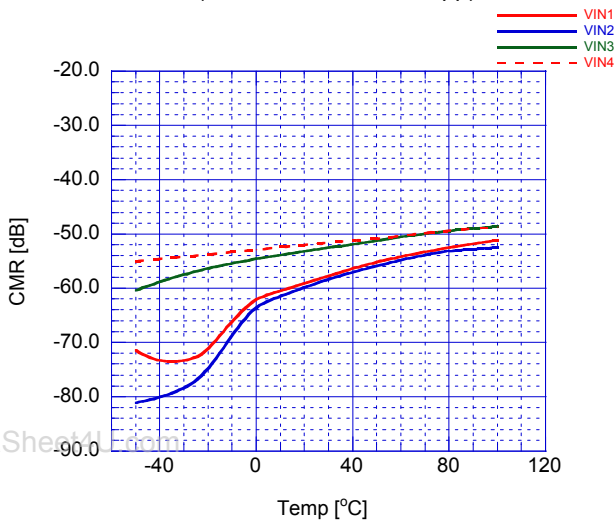

Crosstalk vs. Temperature  
(V+=5V, Vin=4.43MHz 1Vpp, Vin1 to Vin2,3,4)

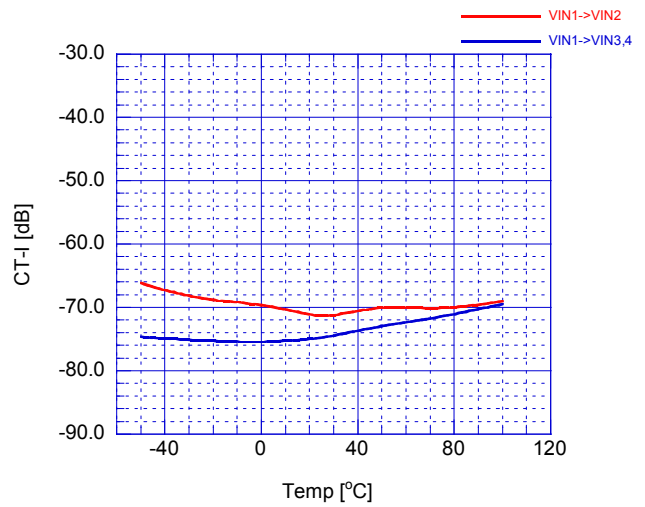

Crosstalk vs. Temperature  
(V+=5V, Vin=4.43MHz 1Vpp, Vin2 to Vin1,3,4)

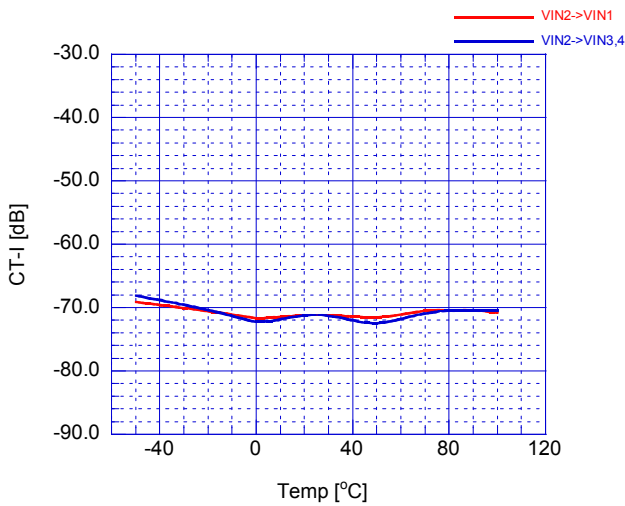

Crosstalk vs. Temperature  
(V+=5V, Vin=4.43MHz 1Vpp, Vin3 to Vin1,2,4)

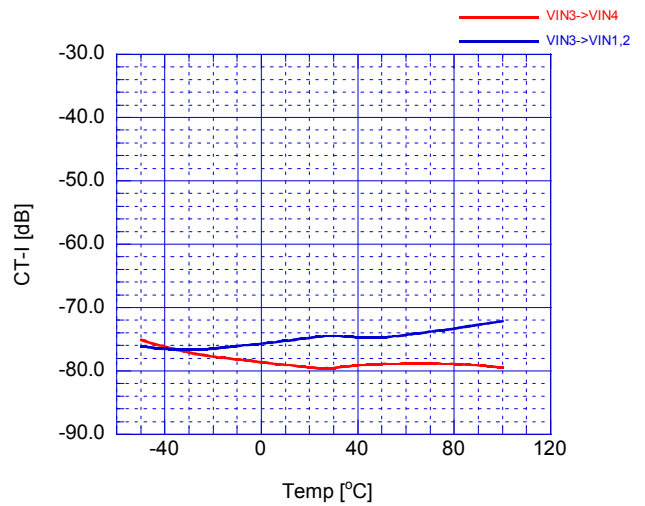

Crosstalk vs. Temperature  
(V+=5V, Vin=4.43MHz 1Vpp, Vin4 to Vin1,2,3)

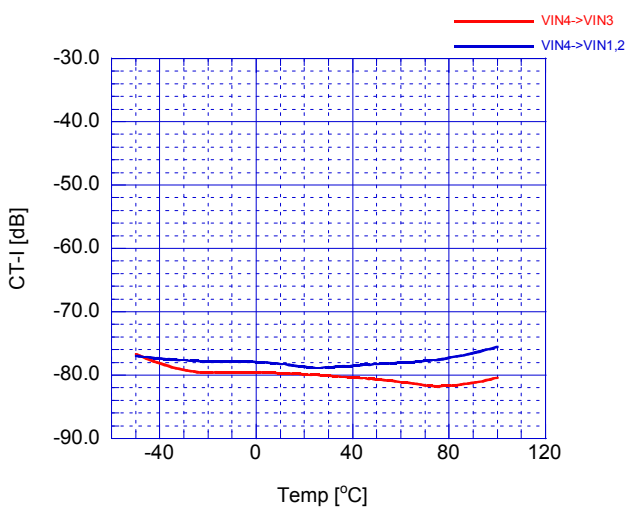

Differential Gain vs. Temperature  
(V+=5V, Vin=1Vpp 10Step signal)

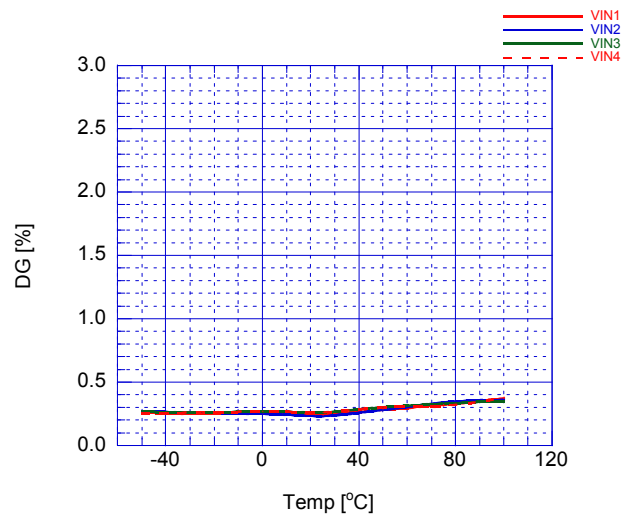

## TYPICAL CHARACTERISTICS

Differential Phase vs. Temperature  
(V+=5V, Vin=1Vpp 10Step signal)

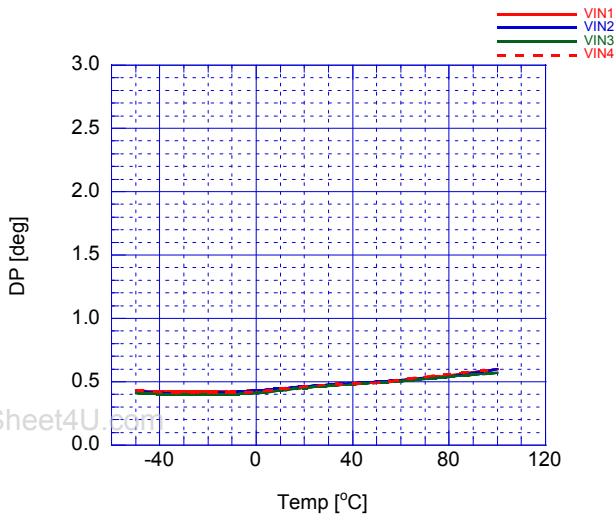

SW Change Voltage vs. Temperature  
(V+=5V)

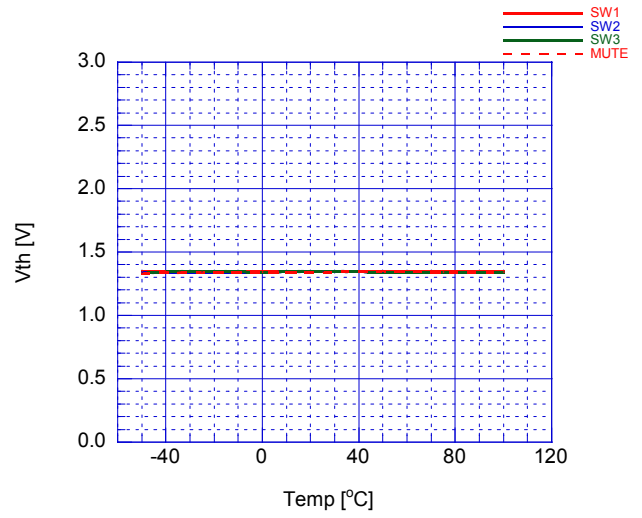

[CAUTION]  
The specifications on this databook are only given for information, without any guarantee as regards either mistakes or omissions. The application circuits in this databook are described only to show representative usages of the product and not intended for the guarantee or permission of any right including the industrial rights.