



**ATTENTION**  
OBSERVE PRECAUTIONS  
FOR HANDLING  
ELECTROSTATIC  
DISCHARGE  
SENSITIVE

**1206RGBCT-CA**

**RED  
GREEN  
BLUE**

**Features**

- 3.2mmx1.5mm SMT LED, 0.68mm THICKNESS.
- LOW POWER CONSUMPTION.
- ONE RED, ONE GREEN AND ONE BLUE CHIPS IN ONE PACKAGE.
- CAN PRODUCE ANY COLOR IN VISIBLE SPECTRUM, INCLUDING WHITE LIGHT.
- PACKAGE : 3000PCS / REEL.

**Description**

The Red source color devices are made with DH InGaAlP on GaAs substrate Light Emitting Diode.

The Green source color devices are made with GaP on Sapphire Light Emitting Diode.

The Blue source color devices are made with GaN on Sapphire Light Emitting Diode.

Static electricity and surge damage the LEDs.

It is recommended to use a wrist band or anti-electrostatic glove when handling the LEDs.

All devices, equipment and machinery must be electrically grounded.

**Package Dimensions**

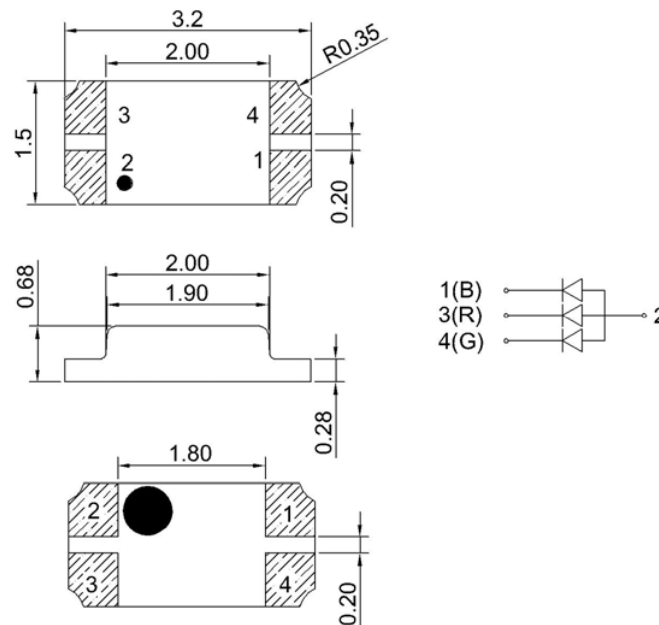

Notes:

1. All dimension units are millimeters.
2. All dimension tolerance is  $\pm 0.2\text{mm}$  unless otherwise noted.
3. An epoxy meniscus may extend about 1.5mm down the leads.
4. Burr around bottom of epoxy may be 0.5mm max..



### Selection Guide

Part No.	Lens Type	Iv (mcd) @ 20mA									Viewing Angle
		Dice	RED (InGaAlP)		Dice	GREEN (GaP)		Dice	BLUE (GaN)		
		Code	Min.	Max.	Code	Min.	Max.	Code	Min.	Max.	2θ1/2
1206RGBCT-CA	WATER CLEAR	J	90	125	M	210	276	H	55	70	120°
		K	125	160	N	276	355	I	70	90	
		L	160	210	O	355	460	J	90	125	

Note:

1. 01/2 is the angle from optiC-AI centerline where the luminous intensity is 1/2 the optiC-AI centerline value.

### ElectriC-AI / OptiC-AI Characteristics at TA=25°C

Symbol	Parameter	Device		Red		Device		Green		Device		Blue		Units	Test Conditions
		Code	Typ.	Max.	Code	Typ.	Max.	Code	Typ.	Max.	Code	Typ.	Max.		
λD	Dominate Wavelength	A	621	624	F	515	518	D	464	467	nm	If=20mA			
		B	624	627	G	518	521	E	467	470					
		C	627	630	H	521	524	F	470	473					
C	C-Apacitance		15			45			110		pF	VF=0V;f=1MHz			
VF	Forward Voltage	A	1.6	1.8	H	3.0	3.2	H	3.0	3.2	V	If=20mA			
		B	1.8	2.0	I	3.2	3.4	I	3.2	3.4					
		C	2.0	2.2	J	3.4	3.6	J	3.4	3.6					
					K	3.6	3.8	K	3.6	3.8					
IR	Reverse Current			10		10			10		uA	VR = 5V			

### Absolute Maximum Ratings at TA=25°C

Parameter	Red	Green	Blue	Units
Power dissipation	75	95	114	mW
DC Forward Current	30	25	30	mA
Peak Forward Current [1]	160	150	160	mA
Reverse Voltage	5			V
Operating/Storage Temperature	-40°C TO +80°C			

Note:

1. 1/10 Duty Cycle, 0.1ms Pulse Width.



**RED 1206RGBCT-CA**  
**GREEN**  
**BLUE**

**Reliability Test Items And Conditions**

The reliability of products shall be satisfied with items listed below.  
 Confidence level :90% LTPD :10%

No.	Items	Test Condition	Test Hours/Cycles	Sample Size	Ac/Rc
1	Reflow	Temp:240°C±5°C Min.5 sec.	6 Min.	22Pcs.	0/1
2	Temperature Cycle	H:+100°C 15 min. ∞ 5 min L:-40°C 15 min.	300 Cycles	22Pcs.	0/1
3	Thermal Shock	H:+100°C 5 min. ∞ 10 sec. L:-10°C 5 min.	300 Cycles	22Pcs.	0/1
4	High Temperature Storage	Temp.:100°C	1000Hrs.	22Pcs.	0/1
5	Low Temperature Storage	Temp.: -55°C	1000Hrs.	22Pcs.	0/1
6	DC Operating Life	I <sub>f</sub> =20mA	1000Hrs.	22Pcs.	0/1
7	High Temperature/High Humidity	85°C/R.H85%	1000Hrs.	22Pcs.	0/1

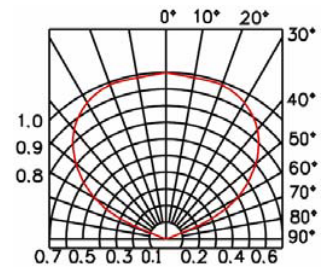
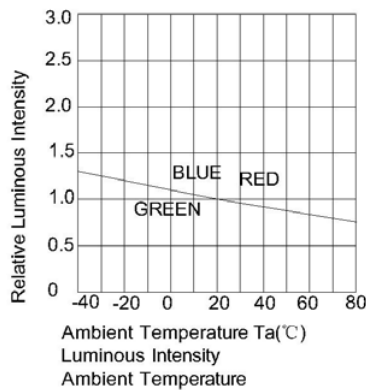
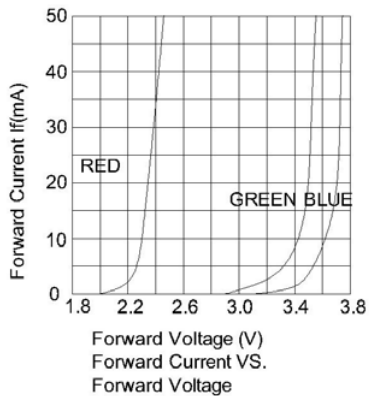
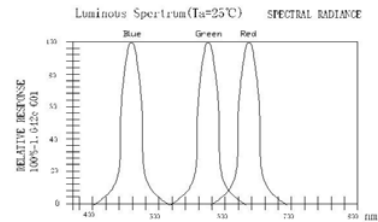
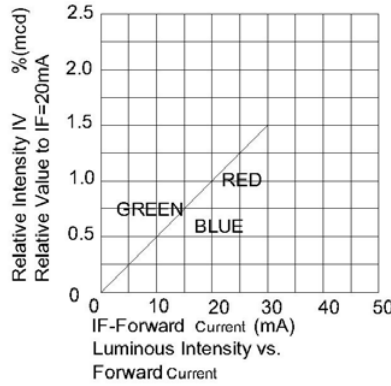
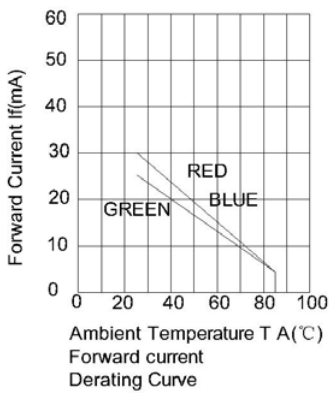



## 1206RGBCT-CA

### SMT Reflow Soldering Instructions

Number of reflow process shall be less than 2 times and cooling process to normal temperature is required between first and second soldering process.

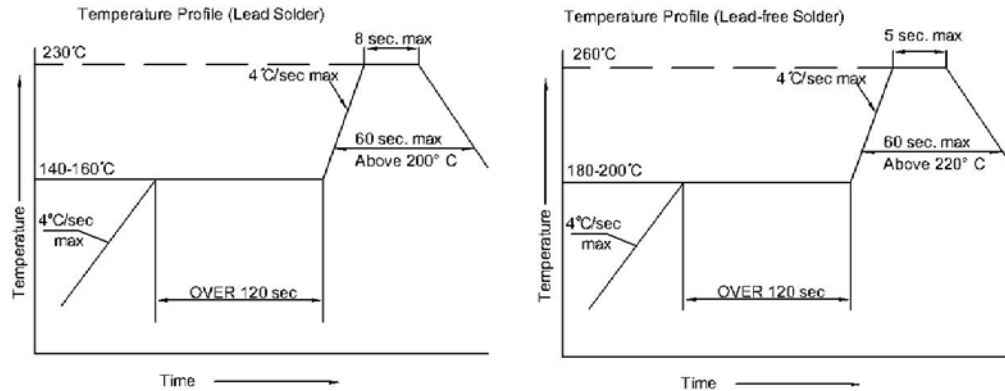

### Recommended Soldering Pattern (Units : mm)

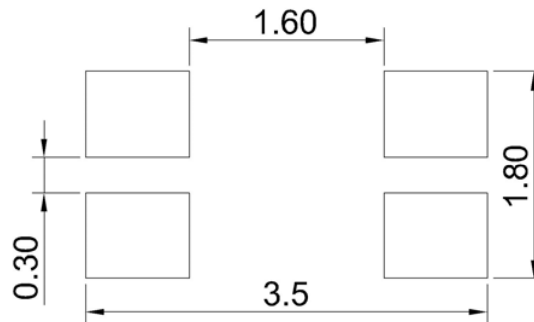

### Tape Specifications (Units : mm)

