



200-300 WATT MEDICAL SWITCHING POWER SUPPLIES

DESCRIPTION

The PM300 series comprising single and multiple output models for 200 to 300 watts of continuous output power is specially designed for medical applications not for patient contact. They operate at 90 to 264 VAC input voltage without the need of a selector strap. All auxiliary outputs are with magnetic amplifier to keep regulation. The units are constructed on a printed circuit board with a U-bracket for mechanical support and heat sinking. A cover-and-fan assembly can be added during manufacturing.

PM300 SERIES

CE (MDD)

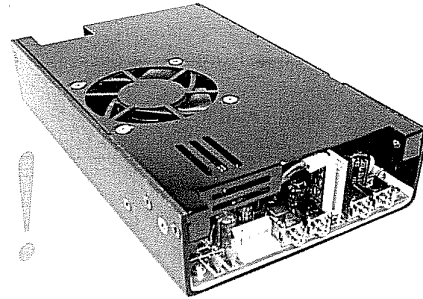

New!!!

FEATURES

- EN61000-3-2 class A and D compliant
- Power Factor 0.98 typical
- Overvoltage protection
- Short-circuit protection
- Power Fail Detect (PFD)
- 100% burn-in at full rated load
- Remote sense on output #1 and output #2
- Remote inhibit – TTL high disables output

Safety Standard Approvals :



UL2601-1, CSA C22.2 No. 601.1
File No. E178020



TÜV EN60601-1
Certificate No. TA50070068

INPUT SPECIFICATIONS

Input voltage : 90 to 264 VAC
Input frequency : 47 to 63 Hz
Input current : 4.7A (rms) for 115VAC
2.3A (rms) for 230VAC
Leakage current : 100uA max. @ 115VAC, 60Hz
165uA max. @ 230VAC, 50Hz

ENVIRONMENTAL SPECIFICATIONS

Operating temperature : 0°C to +70°C
Storage temperature : -40°C to +85°C
Relative humidity : 5% to 95% non-condensing
Derating : Derate from 100% at +50°C
linearly to 50% at +70°C
200/250/300 watts continuous
output power at 35 CFM forced
air cooling or 100/125/150 watts
at convention cooling

OUTPUT SPECIFICATIONS

Output voltage/current : See rating chart
Total output power : See rating chart
Ripple and Noise : 2% peak to peak maximum
Overvoltage protection : Provided on output #1 only; set
at 115 – 140% of its nominal
Output voltage
Overcurrent protection : All outputs protected to short
circuit conditions
Temperature coefficient : All outputs ± 0.04% /°C
maximum
Transient response : Maximum excursion of 4% or
better on all models, recovering
to 1% of final value within
500us after a 25% step load
change
PFD signal : TTL logic high for normal
operation and TTL logic low
upon loss of input power. This
signal appears at least 1 ms
prior to master output dropping
5% below its nominal value.
This signal also provides a
minimum delay of 100 ms after
master output is within
regulation.
Remote inhibit : Requires an external TTL high
level signal to inhibit outputs
for standard models.

GENERAL SPECIFICATIONS

Switching frequency : 70KHz ±10KHz
Power factor : 0.98 typical
Efficiency : 70% minimum on all models
Hold-up time : 12 msec minimum at 110VAC
Line regulation : ±0.2% maximum at full load
Inrush current : 30 amps @ 115VAC, or 60 amps
@230VAC at 25°C cold start
Withstand voltage : 4000VAC from input to output
1500VAC from input to ground
500VAC from output to ground
MTBF : 300,000 hours minimum at full load at
25°C ambient, calculated per MIL-HDBK-
217F
EMC performance (EN60601-1-2: 2001)
EN55011: Class B conducted, Class B radiated
EN61000-3-2: Harmonic distortion, Class A and D
EN61000-3-3: Line flicker
EN61000-4-2: ESD, ±8KV air and ±6KV contact
EN61000-4-3: Radiated immunity, 3V/m
EN61000-4-4: Fast transient/burst, ±2KV
EN61000-4-5: Surge, ±1KV diff., ±2KV com.
EN61000-4-6: Conducted immunity, 3Vrms
EN61000-4-8: Magnetic field immunity, 3A/m
EN61000-4-11: Voltage dips, 30% reduction for 500ms, 60%
reduction for 100ms and >95% reduction for
10ms

UNIVERSAL INPUT

PM300 SERIES

OUTPUT VOLTAGE/CURRENT RATING CHART

(1) (2) (6) Model	Output # 1 (3)				Output # 2 (3)				Output # 3 (4)				Output # 4 (4)				Max. Output Power (5)
	Vnom.	Imin.	Imax.	Tol.	Vnom.	Imin.	Imax.	Tol.	Vnom.	Imin.	Imax.	Tol.	Vnom.	Imin.	Imax.	Tol.	
PM300-10-3	3.3V	3.0A	60A	3%													200W
PM300-10	5.1V	3.0A	60A	2%													300W
PM300-12	12V	1.2A	25A	2%													300W
PM300-13	15V	1.0A	20A	2%													300W
PM300-14	24V	0.6A	12.5A	2%													300W
PM300-16	30V	0.5A	10A	2%													300W
PM300-18	48V	0.5A	6.3A	2%													300W
PM300-40-3	3.3V	3.0A	35A	3%	5.1V	2.0A	22A	2%	12V	0A	4A	4%	12V	0A	4A	4%	250W
PM300-40	5.1V	2.0A	35A	2%	12V	1.0A	10A	2%	12V	0A	4A	4%	5.1V	0A	4A	4%	300W
PM300-41	5.1V	2.0A	35A	2%	15V	0.8A	8A	2%	15V	0A	4A	4%	24V	0A	2.5A	4%	300W
PM300-42	5.1V	2.0A	35A	2%	12V	1.0A	10A	2%	12V	0A	4A	4%	12V	0A	4A	4%	300W
PM300-45	5.1V	2.0A	35A	2%	12V	1.0A	10A	2%	12V	0A	4A	4%	24V	0A	2.5A	4%	300W
PM300-46	5.1V	2.0A	35A	2%	12V	1.0A	10A	2%	12V	0A	4A	4%	15V	0A	4A	4%	300W
PM300-47	5.1V	2.0A	35A	2%	24V	0.5A	5A	2%	12V	0A	4A	4%	12V	0A	4A	4%	300W
PM300-48	5.1V	2.0A	35A	2%	24V	0.5A	5A	2%	5.1V	0A	4A	4%	15V	0A	4A	4%	300W
PM300-49	5.1V	2.0A	35A	2%	12V	1.0A	10A	2%	5.1V	0A	4A	4%	24V	0A	2.5A	4%	300W
PM300-410	24V	0.5A	6.3A	2%	12V	1.0A	10A	2%	5.1V	0A	4A	4%	12V	0A	4A	4%	300W
PM300-411	24V	0.5A	6.3A	2%	12V	1.0A	10A	2%	5.1V	0A	4A	4%	24V	0A	2.5A	4%	300W
PM300-412	24V	0.5A	6.3A	2%	12V	1.0A	10A	2%	12V	0A	4A	4%	12V	0A	4A	4%	300W
PM300-413	24V	0.5A	6.3A	2%	24V	0.5A	5A	2%	5.1V	0A	4A	4%	15V	0A	4A	4%	300W
PM300-414	24V	0.5A	6.3A	2%	24V	0.5A	5A	2%	12V	0A	4A	4%	12V	0A	4A	4%	300W

Notes:

- Add suffix "B" for U-bracket format or "C" for enclosed format, e.g. PM300-45C.
- All outputs are floating. It can be connected externally for positive or negative output.
- Output #1 & #2 can be adjusted within $\pm 5\%$ of their nominal voltage.
- Output #3 & #4 can be adjusted within $\pm 15\%$ of their nominal voltage.
- 300 watts for "C" version with cover-and-fan assembly. 150 watts for "B" version without moving air (maximum current of output #1 & #2 derated to 50%), or 300 watts with 35 CFM forced air provided by user.
- PM300-10-3 is rated 200 watt with 35 CFM forced air cooling or 100 watt convection cooled. PM300-40-3 is rated 250 watt with 35 CFM forced air cooling (maximum current of output #1 & #2 derated to 50%) or 125 watt convection cooled.
- Single output models may be operated at no-load. At no-load, output voltage tolerance increases to 10%.

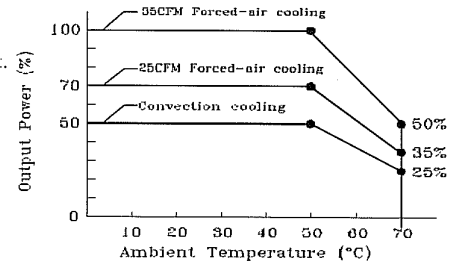

DERATING CURVE

MECHANICAL SPECIFICATIONS

Single output models

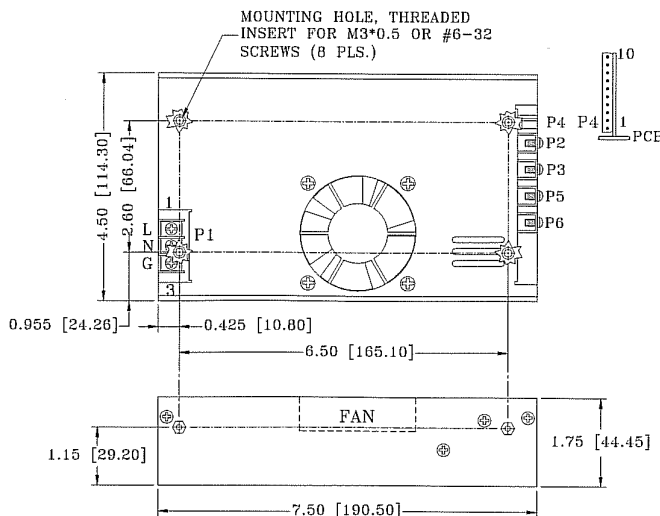

NOTES:

- Dimensions shown in inch [mm]
- Tolerance 0.02 [0.5] maximum
- Input connector P1 is Dinkle DT-35-B01W-03 screws are M3, Nickel plated.
- Connector P4 mates with Molex housing 50-37-5103 and pins 5263.
- Connectors P2,P3,P5 and P6: M3*0.5 screw connections
- Weight: 1.20 Kgs (2.64 Lbs.) approx.

UNIVERSAL INPUT

MECHANICAL SPECIFICATIONS

PM300 SERIES

Multiple output models

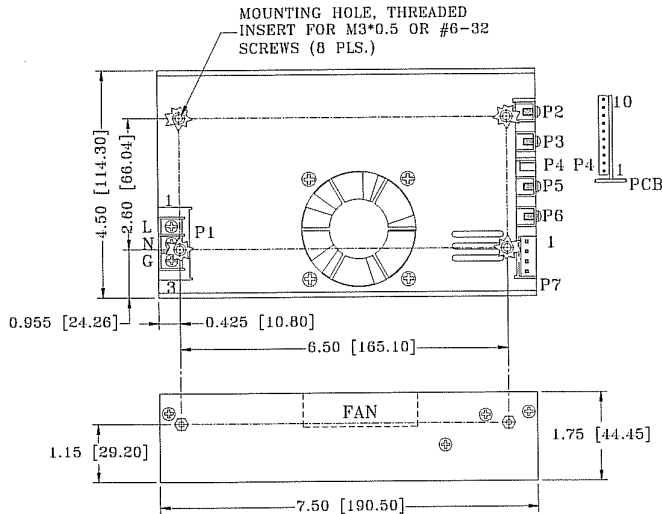

NOTES:

1. Dimensions shown in inch [mm]
2. Tolerance 0.02 [0.5] maximum
3. Input connector P1 is Dinkle DT-35-B01W-03 screws are M3, Nickel plated.
4. Connector P4 mates with Molex housing 50-37-5103 and pins 5263.
5. Connectors P2, P3, P5 and P6: M3*0.5 screw connections
6. Output connector P7 mates with Molex housing 09-50-3041 and Molex 2878 series crimp terminal.
7. Weight: 1.24 Kgs (2.73 Lbs.) approx.

PIN CHART

Single Output models

MODEL	CONN PIN	P1 (AC)			P2	P3	P4			
		1	2	3			1	2	3	4
PM300-10-3 PM300-12 PM300-14 PM300-18	PM300-10 PM300-13 PM300-16	LIVE	NEUTRAL	GROUND	+VO1	+VO1	SIGNAL GROUND (-VO1)	+S (VO1)	-S (VO1)	PFD

MODEL	CONN PIN	P4								P5	P6	P7			
		5	6	7	8	9	10	1	2			3	4		
PM300-10-3 PM300-12 PM300-14 PM300-18	PM300-10 PM300-13 PM300-16	INHIBIT	N.C.	N.C.	N.C.	0V (FAN)	FAN	-VO1	-VO1	VOID	VOID	VOID	VOID		

Multiple output models

MODEL	CONN PIN	P1 (AC)			P2	P3	P4			
		1	2	3			1	2	3	4
PM300-40-3 PM300-41 PM300-45 PM300-47 PM300-49 PM300-411 PM300-413	PM300-40 PM300-42 PM300-46 PM300-48 PM300-410 PM300-412 PM300-414	LIVE	NEUTRAL	GROUND	+VO1	-VO1	SIGNAL GROUND (-VO1)	+S (VO1)	-S (VO1)	PFD

MODEL	CONN PIN	P4								P5	P6	P7			
		5	6	7	8	9	10	1	2			3	4		
PM300-40-3 PM300-41 PM300-45 PM300-47 PM300-49 PM300-411 PM300-413	PM300-40 PM300-42 PM300-46 PM300-48 PM300-410 PM300-412 PM300-414	INHIBIT	N.C.	+S (VO2)	-S (VO2)	0V (FAN)	FAN	+VO2	-VO2	+VO3	-VO3	+VO4	-VO4		