



36Mb QDR™II SRAM

2-WORD BURST

MT54W4MH8B
 MT54W4MH9B
 MT54W2MH18B
 MT54W1MH36B

FEATURES

- DLL circuitry for accurate output data placement
- Separate independent read and write data ports with concurrent transactions
- 100 percent bus utilization DDR READ and WRITE operation
- Fast clock to valid data times
- Full data coherency, providing most current data
- Two-tick burst counter for low DDR transaction size
- Double data rate operation on read and write ports
- Two input clocks (K and K#) for precise DDR timing at clock rising edges only
- Two output clocks (C and C#) for precise flight time and clock skew matching—clock and data delivered together to receiving device
- Single address bus
- Simple control logic for easy depth expansion
- Internally self-timed, registered writes
- +1.8V core and HSTL I/O
- Clock-stop capability
- 15mm x 17mm, 1mm pitch, 11 x 15 grid FBGA package
- User-programmable impedance output
- JTAG boundary scan

OPTIONS

- Clock Cycle Timing

4ns (250 MHz)	-4
5ns (200 MHz)	-5
6ns (167 MHz)	-6
7.5ns (133 MHz)	-7.5
- Configurations

4 Meg x 8	MT54W4MH8B
4 Meg x 9	MT54W4MH9B
2 Meg x 18	MT54W2MH18B
1 Meg x 36	MT54W1MH36B
- Package

165-ball, 15mm x 17mm FBGA	F
----------------------------	---

MARKING¹

NOTE:

1. A Part Marking Guide for the FBGA devices can be found on Micron's Web site—<http://www.micron.com/number-guide>.

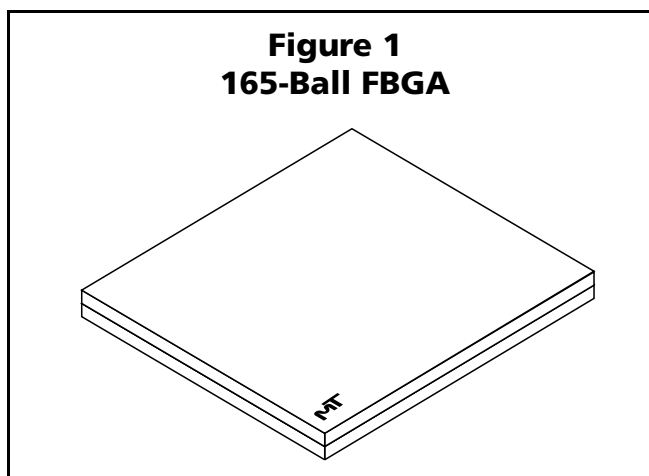

VALID PART NUMBERS

PART NUMBER	DESCRIPTION
MT54W4MH8BF-xx	4 Meg x 8, QDRIIb2 FBGA
MT54W4MH9BF-xx	4 Meg x 9, QDRIIb2 FBGA
MT54W2MH18BF-xx	2 Meg x 18, QDRIIb2 FBGA
MT54W1MH36BF-xx	1 Meg x 36, QDRIIb2 FBGA

GENERAL DESCRIPTION

The Micron[®] QDR™II (Quad Data Rate™) synchronous, pipelined burst SRAM employs high-speed, low-power CMOS designs using an advanced 6T CMOS process.

The QDR architecture consists of two separate DDR (double data rate) ports to access the memory array. The read port has dedicated data outputs to support READ operations. The write port has dedicated data inputs to support WRITE operations. This architecture eliminates the need for high-speed bus turnaround. Access to each port is accomplished using a common address bus. Addresses for reads and writes are latched on rising edges of the K and K# input clocks, respectively. Each address location is associated with two words that burst sequentially into or out of the device.



GENERAL DESCRIPTION (continued)

Since data can be transferred into and out of the device on every rising edge of both clocks (K and K#, C and C#), memory bandwidth is maximized while system design is simplified by eliminating bus turn-arounds.

Depth expansion is accomplished with port selects for each port (read R#, write W#), which are received at K rising edge. Port selects permit independent port operation.

All synchronous inputs pass through registers controlled by the K or K# input clock rising edges. Active LOW byte writes (BWx#) permit byte or nibble write selection. Write data and byte writes are registered on the rising edges of both K and K#. The addressing within each burst of two is fixed and sequential, beginning with the lowest and ending with the highest address. All synchronous data outputs pass through output registers controlled by the rising edges of the output clocks (C and C# if provided, otherwise K and K#).

Four balls are used to implement JTAG test capabilities: test mode select (TMS), test data-in (TDI), test clock (TCK), and test data-out (TDO). JTAG circuitry is used to serially shift data to and from the SRAM. JTAG inputs use JEDEC-standard 1.8V I/O levels to shift data during this testing mode of operation.

The SRAM operates from a +1.8V power supply, and all inputs and outputs are HSTL-compatible. The device is ideally suited for applications that benefit from a high-speed, fully-utilized DDR data bus.

Please refer to Micron's Web site (www.micron.com/sramds) for the latest data sheet.

READ/WRITE OPERATIONS

All bus transactions operate on an uninterruptable burst of two data, requiring one full clock cycle of bus utilization. The resulting benefit is that short data transactions can remain in operation on both buses provided that the address rate can be maintained by the system (2x the clock frequency).

READ cycles are pipelined. The request is initiated by asserting R# LOW at K rising edge. Data is delivered after the rising edge of K# (t + 1) using C and C# as the output timing references or using K and K#, if C and C# are tied HIGH. If C and C# are tied HIGH, they may not be toggled during device operation. Output tri-stating is automatically controlled such that the bus is released if no data is being delivered. This permits banked SRAM systems with no complex OE timing generation. Back-to-back READ cycles are initiated every K rising edge.

Figure 2
Functional Block Diagram: 2 Meg x 18

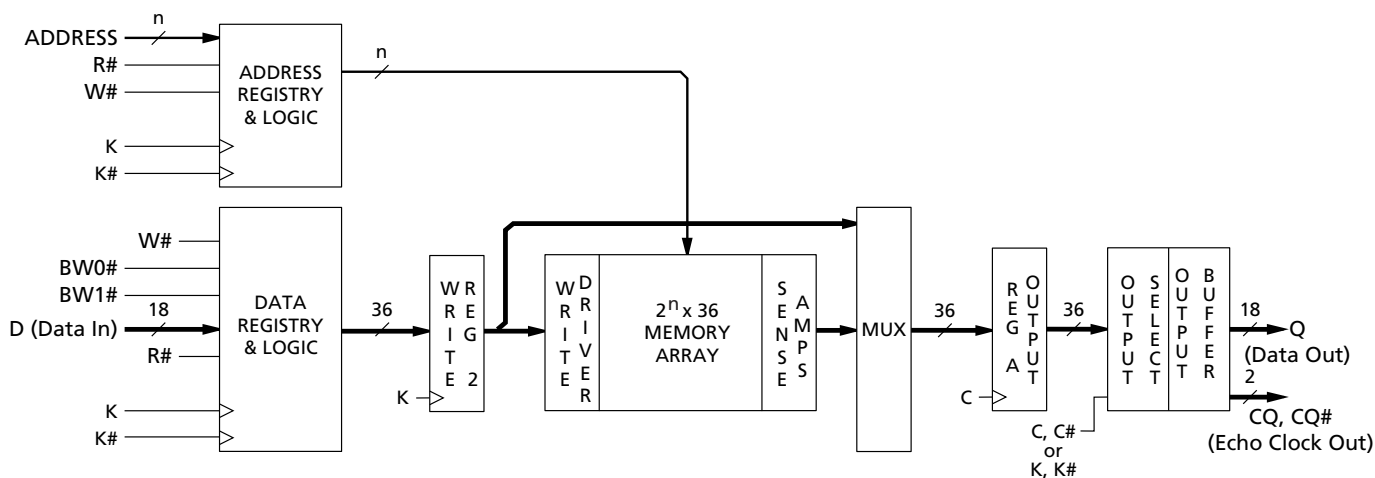

NOTE:

1. The functional block diagram illustrates simplified device operation. See truth table, ball descriptions, and timing diagrams for detailed information. The x8, x9, and x36 operations are the same, with appropriate adjustments of depth and width.
2. n = 20



READ/WRITE OPERATIONS (continued)

WRITE cycles are initiated by W# LOW at K rising edge. The address for the WRITE cycle is provided at the following K# rising edge. Data is expected at the rising edge of K and K#, beginning at the same K that initiated the cycle. Write registers are incorporated to facilitate pipelined, self-timed WRITE cycles and to provide fully coherent data for all combinations of reads and writes. A read can immediately follow a write, even if they are to the same address. Although the write data has not been written to the memory array, the SRAM will deliver the data from the write register instead of using the older data from the memory array. The latest data is always utilized for all bus transactions. WRITE cycles can be initiated on every K rising edge.

PARTIAL WRITE OPERATIONS

BYTE WRITE operations are supported, except for the x8 devices in which nibble write is supported. The active LOW byte write controls, BWx# (NWx#), are registered coincident with their corresponding data. This feature can eliminate the need for some READ-MODIFY-WRITE cycles, collapsing it to a single BYTE/NIBBLE WRITE operation in some instances.

PROGRAMMABLE IMPEDANCE OUTPUT BUFFER

The QDR SRAM is equipped with programmable impedance output buffers. This allows a user to match the driver impedance to the system. To adjust the impedance, an external precision resistor (RQ) is connected between the ZQ ball and V_{SS}. The value of the resistor must be five times the desired impedance. For example, a 350Ω resistor is required for an output impedance of 70Ω. To ensure that output impedance is one-fifth the value of RQ (within 15 percent), the range of RQ is 175Ω to 350Ω. Alternately, the ZQ ball can be connected directly to V_{DDQ}, which will place the device in a minimum impedance mode.

Output impedance updates may be required because variations may occur over time in supply voltage and temperature. The device samples the value of RQ. Impedance updates are transparent to the system; they do not affect device operation, and all data sheet timing and current specifications are met during an update.

The device will power up with an output impedance set at 50Ω. To guarantee optimum output driver impedance after power-up, the SRAM needs 1,024 cycles to update the impedance. The user can operate the part with fewer than 1,024 clock cycles, but optimal output impedance is not guaranteed.

Figure 3
Application Example

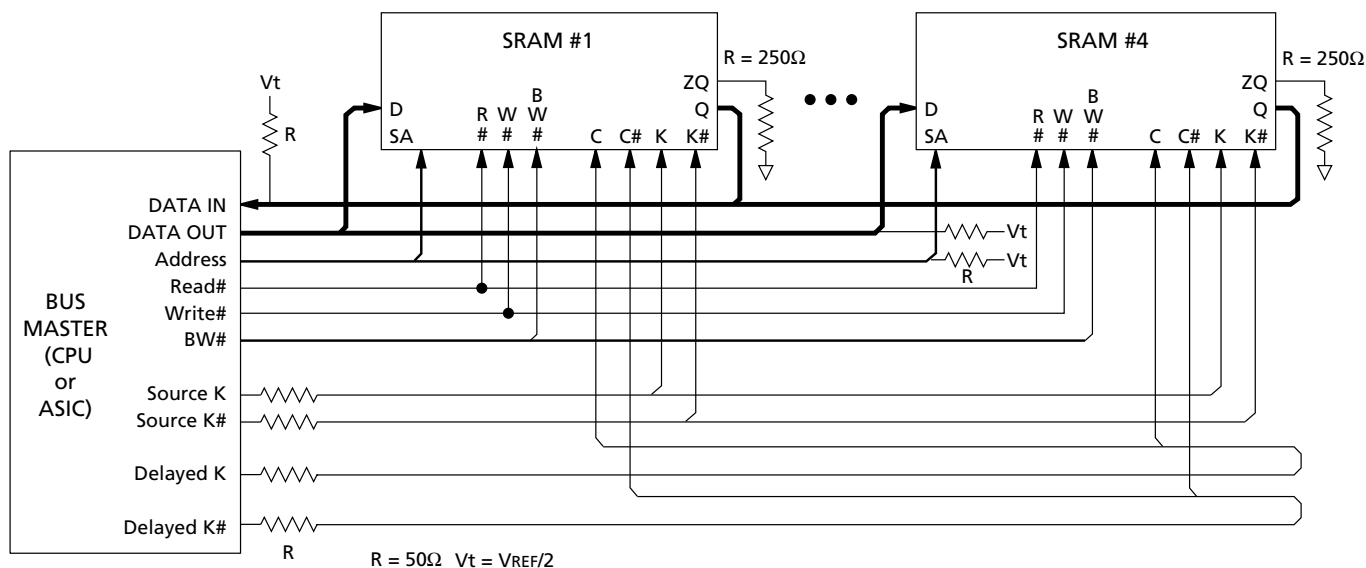

NOTE:

In this approach, the second clock pair drives the C and C# clocks but is delayed such that return data meets data setup and hold times at the bus master.



CLOCK CONSIDERATIONS

This device utilizes internal delay-locked loops for maximum output data valid window. It can be placed into a stopped-clock state to minimize power with a modest restart time of 1,024 clock cycles. Circuitry automatically resets the DLL when the absence of input clock is detected. See Micron Technical Note TN-54-02 for more information on clock DLL start-up procedures.

SINGLE CLOCK MODE

The SRAM can be used with the single K, K# clock pair by tying C and C# HIGH. In this mode, the SRAM will use K and K# in place of C and C#. This mode provides the most rapid data output but does not compensate for system clock skew and flight times.

DEPTH EXPANSION

Port select inputs are provided for the read and write ports. This allows for easy depth expansion. Both port selects are sampled on the rising edge of K only. Each port can be independently selected and deselected and does not affect the operation of the opposite port. All pending transactions are completed prior to a port deselecting. Depth expansion requires replicating R# and W# control signals for each bank if it is desired to have the bank independent of READ and WRITE operations.

4 MEG x 8 BALL ASSIGNMENT (TOP VIEW)
165-BALL FBGA

	1	2	3	4	5	6	7	8	9	10	11
A	CQ#	V _{SS} /SA ¹	SA	W#	NW1# ²	K#	NC/SA ³	R#	SA	SA	CQ
B	NC	NC	NC	SA	NC/SA ⁴	K	NW0# ⁵	SA	NC	NC	Q3
C	NC	NC	NC	V _{SS}	SA	SA	SA	V _{SS}	NC	NC	D3
D	NC	D4	NC	V _{SS}	V _{SS}	V _{SS}	V _{SS}	V _{SS}	NC	NC	NC
E	NC	NC	Q4	V _{DDQ}	V _{SS}	V _{SS}	V _{SS}	V _{DDQ}	NC	D2	Q2
F	NC	NC	NC	V _{DDQ}	V _{DD}	V _{SS}	V _{DD}	V _{DDQ}	NC	NC	NC
G	NC	D5	Q5	V _{DDQ}	V _{DD}	V _{SS}	V _{DD}	V _{DDQ}	NC	NC	NC
H	DLL#	V _{REF}	V _{DDQ}	V _{DDQ}	V _{DD}	V _{SS}	V _{DD}	V _{DDQ}	V _{DDQ}	V _{REF}	ZQ
J	NC	NC	NC	V _{DDQ}	V _{DD}	V _{SS}	V _{DD}	V _{DDQ}	NC	Q1	D1
K	NC	NC	NC	V _{DDQ}	V _{DD}	V _{SS}	V _{DD}	V _{DDQ}	NC	NC	NC
L	NC	Q6	D6	V _{DDQ}	V _{SS}	V _{SS}	V _{SS}	V _{DDQ}	NC	NC	Q0
M	NC	NC	NC	V _{SS}	V _{SS}	V _{SS}	V _{SS}	V _{SS}	NC	NC	D0
N	NC	D7	NC	V _{SS}	SA	SA	SA	V _{SS}	NC	NC	NC
P	NC	NC	Q7	SA	SA	C	SA	SA	NC	NC	NC
R	TDO	TCK	SA	SA	SA	C#	SA	SA	SA	TMS	TDI

NOTE:

1. Expansion address: 2A for 72Mb
2. NW1# controls writes to D4:D7
3. Expansion address: 7A for 144Mb
4. Expansion address: 5B for 288Mb
5. NW0# controls writes to D0:D3

4 MEG x 9 BALL ASSIGNMENT (TOP VIEW)
165-BALL FBGA

	1	2	3	4	5	6	7	8	9	10	11
A	CQ#	V _{SS} /SA ¹	SA	W#	NC	K#	NC/SA ²	R#	SA	SA	CQ
B	NC	NC	NC	SA	NC/SA ³	K	BW0# ⁴	SA	NC	NC	Q4
C	NC	NC	NC	V _{SS}	SA	SA	SA	V _{SS}	NC	NC	D4
D	NC	D5	NC	V _{SS}	V _{SS}	V _{SS}	V _{SS}	V _{SS}	NC	NC	NC
E	NC	NC	Q5	V _{DDQ}	V _{SS}	V _{SS}	V _{SS}	V _{DDQ}	NC	D3	Q3
F	NC	NC	NC	V _{DDQ}	V _{DD}	V _{SS}	V _{DD}	V _{DDQ}	NC	NC	NC
G	NC	D6	Q6	V _{DDQ}	V _{DD}	V _{SS}	V _{DD}	V _{DDQ}	NC	NC	NC
H	DLL#	V _{REF}	V _{DDQ}	V _{DDQ}	V _{DD}	V _{SS}	V _{DD}	V _{DDQ}	V _{DDQ}	V _{REF}	ZQ
J	NC	NC	NC	V _{DDQ}	V _{DD}	V _{SS}	V _{DD}	V _{DDQ}	NC	Q2	D2
K	NC	NC	NC	V _{DDQ}	V _{DD}	V _{SS}	V _{DD}	V _{DDQ}	NC	NC	NC
L	NC	Q7	D7	V _{DDQ}	V _{SS}	V _{SS}	V _{SS}	V _{DDQ}	NC	NC	Q1
M	NC	NC	NC	V _{SS}	V _{SS}	V _{SS}	V _{SS}	V _{SS}	NC	NC	D1
N	NC	D8	NC	V _{SS}	SA	SA	SA	V _{SS}	NC	NC	NC
P	NC	NC	Q8	SA	SA	C	SA	SA	NC	D0	Q0
R	TDO	TCK	SA	SA	SA	C#	SA	SA	SA	TMS	TDI

NOTE:

1. Expansion address: 2A for 72Mb
2. Expansion address: 7A for 144Mb
3. Expansion address: 5B for 288Mb
4. BW0# controls writes to D0:D8

2 MEG x 18 BALL ASSIGNMENT (TOP VIEW)
165-BALL FBGA

	1	2	3	4	5	6	7	8	9	10	11
A	CQ#	V _{SS} /SA ¹	SA	W#	BW1# ²	K#	NC/SA ³	R#	SA	V _{SS} /SA ⁴	CQ
B	NC	Q9	D9	SA	NC	K	BW0# ⁵	SA	NC	NC	Q8
C	NC	NC	D10	V _{SS}	SA	SA	SA	V _{SS}	NC	Q7	D8
D	NC	D11	Q10	V _{SS}	V _{SS}	V _{SS}	V _{SS}	V _{SS}	NC	NC	D7
E	NC	NC	Q11	V _{DDQ}	V _{SS}	V _{SS}	V _{SS}	V _{DDQ}	NC	D6	Q6
F	NC	Q12	D12	V _{DDQ}	V _{DD}	V _{SS}	V _{DD}	V _{DDQ}	NC	NC	Q5
G	NC	D13	Q13	V _{DDQ}	V _{DD}	V _{SS}	V _{DD}	V _{DDQ}	NC	NC	D5
H	DLL#	V _{REF}	V _{DDQ}	V _{DDQ}	V _{DD}	V _{SS}	V _{DD}	V _{DDQ}	V _{DDQ}	V _{REF}	ZQ
J	NC	NC	D14	V _{DDQ}	V _{DD}	V _{SS}	V _{DD}	V _{DDQ}	NC	Q4	D4
K	NC	NC	Q14	V _{DDQ}	V _{DD}	V _{SS}	V _{DD}	V _{DDQ}	NC	D3	Q3
L	NC	Q15	D15	V _{DDQ}	V _{SS}	V _{SS}	V _{SS}	V _{DDQ}	NC	NC	Q2
M	NC	NC	D16	V _{SS}	V _{SS}	V _{SS}	V _{SS}	V _{SS}	NC	Q1	D2
N	NC	D17	Q16	V _{SS}	SA	SA	SA	V _{SS}	NC	NC	D1
P	NC	NC	Q17	SA	SA	C	SA	SA	NC	D0	Q0
R	TDO	TCK	SA	SA	SA	C#	SA	SA	SA	TMS	TDI

NOTE:

1. Expansion address: 2A for 144Mb
2. BW1# controls writes to D9:D17
3. Expansion address: 7A for 288Mb
4. Expansion address: 10A for 72Mb
5. BW0# controls writes to D0:D8

1 MEG x 36 BALL ASSIGNMENT (TOP VIEW)
165-BALL FBGA

	1	2	3	4	5	6	7	8	9	10	11
A	CQ#	Vss/SA ¹	NC/SA ²	W#	BW2# ³	K#	BW1# ⁴	R#	SA	Vss/SA ⁵	CQ
B	Q27	Q18	D18	SA	BW3# ⁶	K	BW0# ⁷	SA	D17	Q17	Q8
C	D27	Q28	D19	Vss	SA	SA	SA	Vss	D16	Q7	D8
D	D28	D20	Q19	Vss	Vss	Vss	Vss	Vss	Q16	D15	D7
E	Q29	D29	Q20	VDDQ	Vss	Vss	Vss	VDDQ	Q15	D6	Q6
F	Q30	Q21	D21	VDDQ	VDD	Vss	VDD	VDDQ	D14	Q14	Q5
G	D30	D22	Q22	VDDQ	VDD	Vss	VDD	VDDQ	Q13	D13	D5
H	DLL#	VREF	VDDQ	VDDQ	VDD	Vss	VDD	VDDQ	VDDQ	VREF	ZQ
J	D31	Q31	D23	VDDQ	VDD	Vss	VDD	VDDQ	D12	Q4	D4
K	Q32	D32	Q23	VDDQ	VDD	Vss	VDD	VDDQ	Q12	D3	Q3
L	Q33	Q24	D24	VDDQ	Vss	Vss	Vss	VDDQ	D11	Q11	Q2
M	D33	Q34	D25	Vss	Vss	Vss	Vss	Vss	D10	Q1	D2
N	D34	D26	Q25	Vss	SA	SA	SA	Vss	Q10	D9	D1
P	Q35	D35	Q26	SA	SA	C	SA	SA	Q9	D0	Q0
R	TDO	TCK	SA	SA	SA	C#	SA	SA	SA	TMS	TDI

NOTE:

1. Expansion address: 2A for 288Mb
2. Expansion address: 3A for 72Mb
3. BW2# controls writes to D18:D26
4. BW1# controls writes to D9:D17
5. Expansion address: 10A for 144Mb
6. BW3# controls writes to D27:D35
7. BW0# controls writes to D0:D8



FBGA BALL DESCRIPTIONS

SYMBOL	TYPE	DESCRIPTION
SA	Input	Synchronous Address Inputs: These inputs are registered and must meet the setup and hold times around the rising edge of K for READ cycles and K# for WRITE cycles. See Ball Assignment figures for address expansion inputs. All transactions operate on a burst of two words (one clock period of bus activity). These inputs are ignored when both ports are deselected.
R#	Input	Synchronous Read: When LOW, this input causes the address inputs to be registered and a READ cycle to be initiated. This input must meet setup and hold times around the rising edge of K.
W#	Input	Synchronous Write: When LOW, this input causes the address inputs to be registered and a WRITE cycle to be initiated. This input must meet setup and hold times around the rising edge of K.
BW_# NW_#	Input	Synchronous Byte Writes (or Nibble Writes on the x8): When LOW, these inputs cause their respective Bytes to be registered and written if W# had initiated a WRITE cycle. These signals must meet setup and hold times around the rising edges of K and K# for each of the two rising edges comprising the WRITE cycle. See Ball Assignment figures for signal to data relationships.
K K#	Input	Input Clock: This input clock pair registers address and control inputs on the rising edge of K, and registers data on the rising edge of K and the rising edge of K#. K# is ideally 180 degrees out of phase with K. All synchronous inputs must meet setup and hold times around the clock rising edges.
C C#	Input	Output Clock: This clock pair provides a user-controlled means of tuning device output data. The rising edge of C is used as the output timing reference for second output data. The rising edge of C# is used as the output reference for first output data. Ideally, C# is 180 degrees out of phase with C. C and C# may be tied HIGH to force the use of K and K# as the output reference clocks instead of having to provide C and C# clocks. If tied HIGH, these inputs may not be allowed to toggle during device operation.
TMS TDI	Input	IEEE 1149.1 Test Inputs: 1.8V I/O levels. These balls may be left as No Connects if the JTAG function is not used in the circuit.
TCK	Input	IEEE 1149.1 Clock Input: 1.8V I/O levels. This ball must be tied to V _{SS} if the JTAG function is not used in the circuit.
VREF	Input	HSTL Input Reference Voltage: Nominally V _{DDQ} /2, but may be adjusted to improve system noise margin. Provides a reference voltage for the HSTL input buffer trip point.
ZQ	Input	Output Impedance Matching Input: This input is used to tune the device outputs to the system data bus impedance. DQ output impedance is set to 0.2 x RQ, where RQ is a resistor from this ball to ground. Alternately, this ball can be connected directly to V _{DDQ} to enable the minimum impedance mode. This ball cannot be connected directly to GND or left unconnected.
DLL#	Input	DLL Disable: When LOW, this input causes the DLL to be bypassed for stable, low-frequency operation.
D_	Input	Synchronous Data Inputs: Input data must meet setup and hold times around the rising edges of K and K# during WRITE operations. See Ball Assignment figures for ball site location of individual signals. The x8 device uses D0-D7. Remaining signals are NC. The x9 device uses D0-D8. Remaining signals are NC. The x18 device uses D0-D17. Remaining signals are NC. The x36 device uses D0-D35. Remaining signals are NC.
CQ#, CQ	Output	Synchronous Echo Clock Outputs: The edges of these outputs are tightly matched to the synchronous data outputs and can be used as data valid indication. These signals run freely and do not stop when Q tri-states.
TDO	Output	IEEE 1149.1 Test Output: 1.8V I/O level.

FBGA BALL DESCRIPTIONS (continued)

SYMBOL	TYPE	DESCRIPTION
Q ₋	Output	Synchronous Data Outputs: Output data is synchronized to the respective C and C# or to K and K# rising edges if C and C# are tied HIGH. This bus operates in response to R# commands. See Ball Assignment figures for ball site location of individual signals. The x8 device uses D0-D7. The x9 device uses D0-D8. The x18 device uses Q0-Q17. Remaining signals are NC. The x36 device uses Q0-Q35. Remaining signals are NC.
V _{DD}	Supply	Power Supply: 1.8V nominal. See DC Electrical Characteristics and Operating Conditions for range.
V _{DDQ}	Supply	Power Supply: Isolated Output Buffer Supply. Nominally 1.5V. 1.8V is also permissible. See DC Electrical Characteristics and Operating Conditions for range.
V _{SS}	Supply	Power Supply: GND.
NC	–	No Connect: These signals are not internally connected and may be connected to ground to improve package heat dissipation.

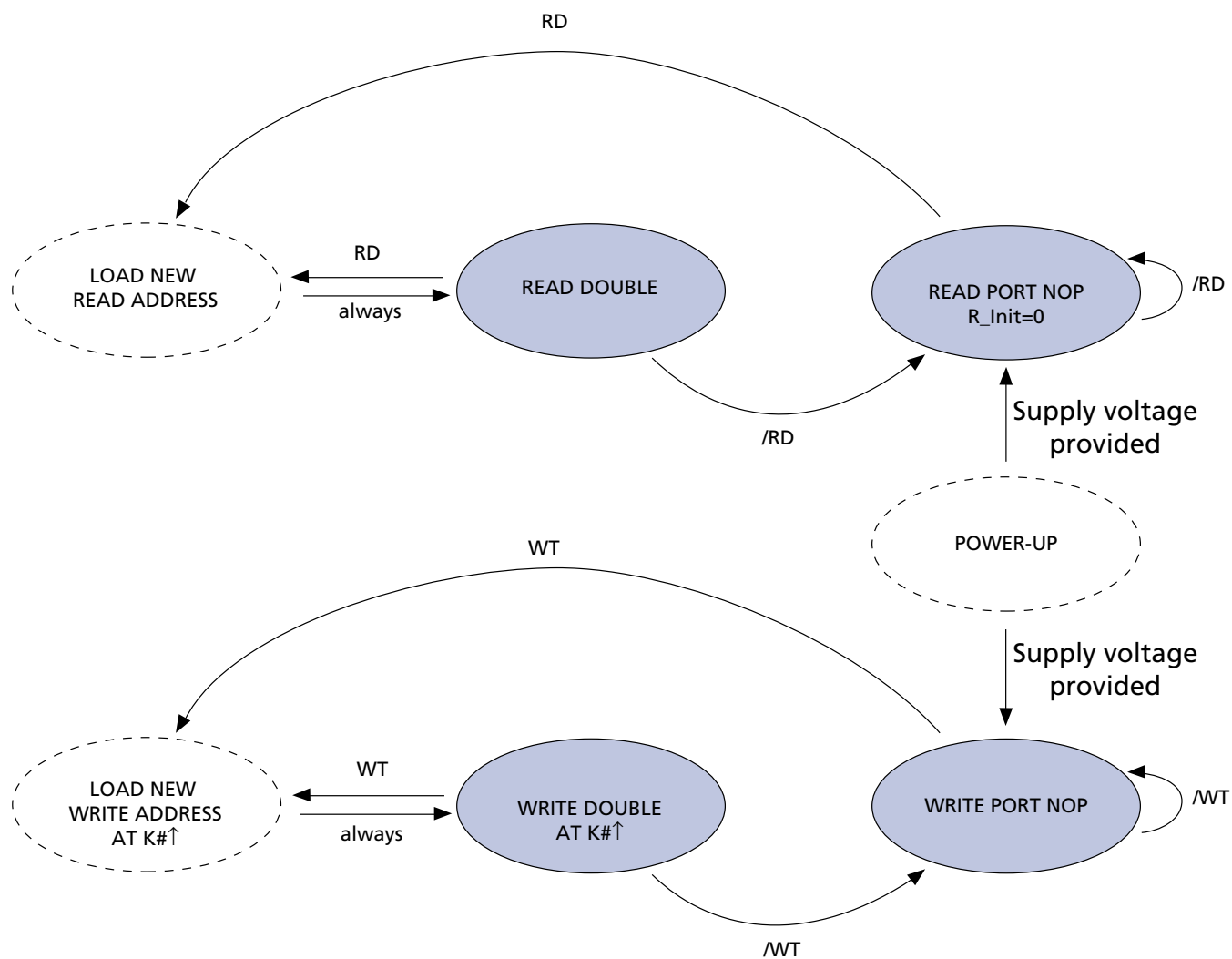
Figure 4
Bus Cycle State Diagram



NOTE:

1. The address is concatenated with one additional internal LSB to facilitate burst operation. The address order is always fixed as xxx . . . xxx + 0, xxx . . . xxx + 1. Bus cycle is terminated at the end of this sequence (burst count = 2).
2. State transitions: RD = (R# = LOW); WT = (W# = LOW).
3. Read and write state machines can be simultaneously active.
4. State machine control timing sequence is controlled by K.



TRUTH TABLE

Notes 1-6

OPERATION	K	R#	W#	D or Q	D or Q
WRITE Cycle: Load address, input write data on consecutive K and K# rising edges	L→H	X	L	DA(A + 0) at K(t)↑	DA(A + 1) at K#(t)↑
READ Cycle: Load address, output data on consecutive C and C# rising edges	L→H	L	X	QA(A + 0) at C#(t + 1)↑	QA(A + 1) at C(t + 2)↑
NOP: No operation	L→H	H	H	D = X Q = High-Z	D = X Q = High-Z
STANDBY: Clock stopped	Stopped	X	X	Previous State	Previous State

BYTE WRITE OPERATION

Notes 7, 8

OPERATION	K	K#	BW0#	BW1#
WRITE D0-17 at K rising edge	L→H		0	0
WRITE D0-17 at K# rising edge		L→H	0	0
WRITE D0-8 at K rising edge	L→H		0	1
WRITE D0-8 at K# rising edge		L→H	0	1
WRITE D9-17 at K rising edge	L→H		1	0
WRITE D9-17 at K# rising edge		L→H	1	0
WRITE nothing at K rising edge	L→H		1	1
WRITE nothing at K# rising edge		L→H	1	1

NOTE:

1. X means "Don't Care." H means logic HIGH. L means logic LOW. ↑ means rising edge; ↓ means falling edge.
2. Data inputs are registered at K and K# rising edges. Data outputs are delivered at C and C# rising edges, except if C and C# are HIGH, then data outputs are delivered at K and K# rising edges.
3. R# and W# must meet setup and hold times around the rising edge (LOW to HIGH) of K and are registered at the rising edge of K.
4. This device contains circuitry that will ensure the outputs will be in High-Z during power-up.
5. Refer to state diagram and timing diagrams for clarification.
6. It is recommended that K = K# = C = C# when clock is stopped. This is not essential, but permits most rapid restart by overcoming transmission line charging symmetrically.
7. Assumes a WRITE cycle was initiated. BW0# and BW1# can be altered for any portion of the BURST WRITE operation, provided that the setup and hold requirements are satisfied.
8. This table illustrates operation for the x18 devices. The x36 device operation is similar, except for the addition of BW2# (controls D18:D26) and BW3# (controls D27:D35). The x9 device operation is similar, except that BW1# and D8:D17 are not available. The x8 device operation is similar, except that NW0# controls D0:D3, and NW1# controls D4:D7.



4 MEG x 8, 4 MEG x 9, 2 MEG x 18, 1 MEG x 36 1.8V V_{DD}, HSTL, QDRIIb2 SRAM

ABSOLUTE MAXIMUM RATINGS*

Voltage on V _{DD} Supply	Relative to V _{SS}	0.5V to +2.8V
Voltage on V _{DDQ} Supply	Relative to V _{SS}	-0.5V to +V _{DD}
V _{IN}		-0.5V to V _{DD} + 0.5V
Storage Temperature		-55°C to +125°C
Junction Temperature**		+125°C
Short Circuit Output Current		±70mA

*Stresses greater than those listed under Absolute Maximum Ratings may cause permanent damage to the device. This is a stress rating only, and functional operation of the device at these or any other conditions above those indicated in the operational sections of this specification is not implied. Exposure to absolute maximum rating conditions for extended periods may affect reliability.

**Maximum junction temperature depends upon package type, cycle time, loading, ambient temperature, and airflow. See Micron Technical Note TN-05-14 for more information.

DC ELECTRICAL CHARACTERISTICS AND OPERATING CONDITIONS

0°C ≤ T_A ≤ +70°C; +1.7V ≤ V_{DD} ≤ +1.9V unless otherwise noted

DESCRIPTION	CONDITIONS	SYMBOL	MIN	MAX	UNITS	NOTES
Input High (Logic 1) Voltage		V _{IH} (DC)	V _{REF} + 0.1	V _{DDQ} + 0.3	V	3, 4
Input Low (Logic 0) Voltage		V _{IL} (DC)	-0.3	V _{REF} - 0.1	V	3, 4
Clock Input Signal Voltage		V _{IN}	-0.3	V _{DDQ} + 0.3	V	3, 4
Input Leakage Current	0V ≤ V _{IN} ≤ V _{DDQ}	I _{LI}	-5	5	μA	
Output Leakage Current	Output(s) disabled, 0V ≤ V _{IN} ≤ V _{DDQ} (Q)	I _{LO}	-5	5	μA	
Output High Voltage	I _{OH} ≤ 0.1mA	V _{OH} (LOW)	V _{DDQ} - 0.2	V _{DDQ}	V	3, 5, 7
	Note 1	V _{OH}	V _{DDQ} /2 - 0.12	V _{DDQ} /2 + 0.12	V	3, 5, 7
Output Low Voltage	I _{OL} ≤ 0.1mA	V _{OL} (LOW)	V _{SS}	0.2	V	3, 5, 7
	Note 2	V _{OL}	V _{DDQ} /2 - 0.12	V _{DDQ} /2 + 0.12	V	3, 5, 7
Supply Voltage		V _{DD}	1.7	1.9	V	3
Isolated Output Buffer Supply		V _{DDQ}	1.4	V _{DD}	V	3, 6
Reference Voltage		V _{REF}	0.68	0.95	V	3

AC ELECTRICAL CHARACTERISTICS AND OPERATING CONDITIONS

0°C ≤ T_A ≤ +70°C; +1.7V ≤ V_{DD} ≤ +1.9V unless otherwise noted

DESCRIPTION	CONDITIONS	SYMBOL	MIN	MAX	UNITS	NOTES
Input High (Logic 1) Voltage		V _{IH} (AC)	V _{REF} + 0.2	-	V	3, 4, 8
Input Low (Logic 0) Voltage		V _{IL} (AC)	-	V _{REF} - 0.2	V	3, 4, 8

NOTE:

- Outputs are impedance-controlled. |I_{OH}| = (V_{DDQ}/2)/(R_Q/5) for values of 175Ω ≤ R_Q ≤ 350Ω.
- Outputs are impedance-controlled. I_{OL} = (V_{DDQ}/2)/(R_Q/5) for values of 175Ω ≤ R_Q ≤ 350Ω.
- All voltages referenced to V_{SS} (GND).
- Overshoot: V_{IH}(AC) ≤ V_{DD} + 0.7V for t ≤ ^tKHKH/2
Undershoot: V_{IL}(AC) ≥ -0.5V for t ≤ ^tKHKH/2
Power-up: V_{IH} ≤ V_{DDQ} + 0.3V and V_{DD} ≤ 1.7V and V_{DDQ} ≤ 1.4V for t ≤ 200ms
During normal operation, V_{DDQ} must not exceed V_{DD}. Control input signals may not have pulse widths less than ^tKHKL (MIN) or operate at cycle rates less than ^tKHKH (MIN).
- AC load current is higher than the shown DC values. AC I/O curves are available upon request.
- Output buffer supply can be set to 1.5V or 1.8V nominal ±0.1 with appropriate derating of AC timing parameters. Consult factory for further information.
- HSTL outputs meet JEDEC HSTL Class I and Class II standards.
- To maintain a valid level, the transitioning edge of the input must:
 - Sustain a constant slew rate from the current AC level through the target AC level, V_{IL}(AC) or V_{IH}(AC).
 - Reach at least the target AC level.
 - After the AC target level is reached, continue to maintain at least the target DC level, V_{IL}(DC) or V_{IH}(DC).



IDD OPERATING CONDITIONS AND MAXIMUM LIMITS

0°C ≤ T_A ≤ +70°C; V_{DD} = MAX unless otherwise noted

DESCRIPTION	CONDITIONS	SYMBOL	TYP	MAX				UNITS	NOTES
				-4	-5	-6	-7.5		
Operating Supply Current: DDR	All inputs ≤ V _{IL} or ≥ V _{IH} ; Cycle time ≥ t _{KHKH} (MIN); Outputs open	I _{DD} (x8, x9, x18) (x36)	TBD	600 800	490 655	415 550	340 450	mA	1, 2, 3
Standby Supply Current: NOP	t _{KHKH} = t _{KHKH} (MIN); Device in NOP state; All addresses/data static	I _{SB1} (x8, x9 x18) (x36)	TBD	200 210	170 180	150 160	125 135	mA	2, 4
Stop Clock Current	Cycle time = 0; Input Static	I _{SB}	TBD	75	75	75	75	mA	2
Output Supply Current: DDR (Information only)	CL = 15pF	I _{DDQ} (x8, x9) (x18) (x36)	TBD	32 71 142	25 57 113	21 47 95	17 38 76	mA	5

CAPACITANCE

DESCRIPTION	CONDITIONS	SYMBOL	TYP	MAX	UNITS	NOTES
Address/Control Input Capacitance	T _A = 25°C; f = 1 MHz	C _I	4	5	pF	6
Output Capacitance (Q)		C _O	6	7	pF	6
Clock Capacitance		C _{CK}	5	6	pF	6

THERMAL RESISTANCE

DESCRIPTION	CONDITIONS	SYMBOL	TYP	UNITS	NOTES
Junction to Ambient (Airflow of 1m/s)	Soldered on a 4.25 x 1.125 inch, 4-layer printed circuit board	θ _{JA}	25	°C/W	6, 7
Junction to Case (Top)		θ _{JC}	10	°C/W	6
Junction to Balls (Bottom)		θ _{JB}	12	°C/W	6, 8

NOTE:

1. I_{DD} is specified with no output current. I_{DD} is linear with frequency. Typical value is measured at 6ns cycle time.
2. Typical values are measured at V_{DD} = 1.8V, V_{DDQ} = 1.5V, and temperature = 25°C.
3. Operating supply currents and burst mode currents are measured at 100 percent bus utilization.
4. NOP currents are valid when entering NOP after all pending READ and WRITE cycles are completed.
5. Average I/O current and power is provided for information purposes only and is not tested. Calculation assumes that all outputs are loaded with C_L (in farads), f = input clock frequency, half of outputs toggle at each transition (for example, n = 18 for x36), C_O = 6pF, V_{DDQ} = 1.5V and uses the equations: Average I/O Power as dissipated by the SRAM is:
P = 0.5 × n × f × V_{DDQ}² × (C_L + 2C_O). Average I_{DDQ} = n × f × V_{DDQ} × (C_L + C_O).
6. This parameter is sampled.
7. Average thermal resistance between the die and the case top surface per MIL SPEC 883 Method 1012.1.
8. Junction temperature is a function of total device power dissipation and device mounting environment. Measured per SEMI G38-87.

AC ELECTRICAL CHARACTERISTICS AND RECOMMENDED OPERATING CONDITIONS 1, 2, 3, 6, 8
 $0^{\circ}\text{C} \leq T_A \leq +70^{\circ}\text{C}; +1.7\text{V} \leq V_{DD} \leq +1.9\text{V}$

DESCRIPTION	SYMBOL	-4		-5		-6		-7.5		UNITS
		MIN	MAX	MIN	MAX	MIN	MAX	MIN	MAX	
Clock										
Clock cycle time (K, K#, C, C#) ⁴	t_{KHKH}	4.00	5.00	5.00	6.00	6.0	7.50	7.50	8.00	ns
Clock phase jitter (K, K#, C, C#) ⁵	$t_{KC\text{ var}}$		0.20		0.20		0.20		0.20	ns
Clock HIGH time (K, K#, C, C#)	t_{KHKL}	1.60		2.00		2.40		3.00		ns
Clock LOW time (K, K#, C, C#)	t_{KLKH}	1.60		2.00		2.40		3.00		ns
Clock to clock# (K \uparrow →K# \uparrow , C \uparrow →C# \uparrow) at t_{KHKH} minimum	$t_{KHK\#H}$	1.80		2.20		2.70		3.38		ns
Clock to clock# (K# \uparrow →K \uparrow , C# \uparrow →C \uparrow)	$t_{K\#HKH}$	1.80		2.20		2.70		3.38		ns
Clock to data clock (K \uparrow →C \uparrow , K# \uparrow →C# \uparrow)	t_{KHCH}	0.00	1.80	0.00	2.30	0.00	2.80	0.00	3.55	ns
DLL lock time (K, C) ⁶	$t_{KC\text{ lock}}$	1,024		1,024		1,024		1,024		cycles
K static to DLL reset	$t_{KC\text{ reset}}$	30		30		30		30		ns
Output Times										
C, C# HIGH to output valid	t_{CHQV}		0.40		0.43		0.45		0.45	ns
C, C# HIGH to output hold	t_{CHQX}	-0.40		-0.43		-0.45		-0.45		ns
C, C# HIGH to echo clock valid	t_{CHCQV}		0.33		0.36		0.38		0.38	ns
C, C# HIGH to echo clock hold	t_{CHCQX}	-0.33		-0.36		-0.38		-0.38		ns
CQ, CQ# HIGH to output valid ⁷	t_{CQHQV}		0.35		0.38		0.40		0.40	ns
CQ, CQ# HIGH to output hold ⁷	t_{CQHQX}	-0.35		-0.38		-0.40		-0.40		ns
C HIGH to output High-Z	t_{CHQZ}		0.0		0.43		0.45		0.45	ns
C HIGH to output Low-Z	t_{CHQX1}	-0.40		-0.43		-0.45		-0.45		ns
Setup Times										
Address valid to K rising edge ⁸	t_{AVKH}	0.40		0.50		0.60		0.70		ns
Control inputs valid to K rising edge ⁸	t_{IVKH}	0.40		0.50		0.60		0.70		ns
Data-in valid to K, K# rising edge ⁸	t_{DVKH}	0.40		0.50		0.60		0.70		ns



AC ELECTRICAL CHARACTERISTICS AND RECOMMENDED OPERATING CONDITIONS 1, 2, 3, 6, 8

 $0^{\circ}\text{C} \leq T_A \leq +70^{\circ}\text{C}; +1.7\text{V} \leq V_{DD} \leq +1.9\text{V}$

DESCRIPTION	SYMBOL	-4		-5		-6		-7.5		UNITS
		MIN	MAX	MIN	MAX	MIN	MAX	MIN	MAX	
Hold Times										
K rising edge to address hold ⁸	t ⁸ _{KHAX}	0.40		0.50		0.60		0.70		ns
K rising edge to control inputs hold ⁸	t ⁸ _{KHIX}	0.40		0.50		0.70		0.70		ns
K, K# rising edge to data-in hold ⁸	t ⁸ _{KHDX}	0.40		0.50		0.60		0.70		ns

NOTE:

1. Test conditions as specified with the output loading shown in Figure 5, unless otherwise noted.
2. Control input signals may not be operated with pulse widths less than t⁸_{KHKL} (MIN).
3. If C and C# are tied HIGH, K and K# become the references for C and C# timing parameters.
4. The device will operate at clock frequencies slower than t⁸_{KHKH} (MAX). See Micron Technical Note TN-54-02 for more information.
5. Clock phase jitter is the variance from clock rising edge to the next expected clock rising edge.
6. V_{DD} slew rate must be less than 0.1V DC per 50ns for DLL lock retention. DLL lock time begins once V_{DD} and input clock are stable.
7. Echo clock is tightly controlled to data valid/data hold. By design, there is a ±0.1ns variation from echo clock to data. The data sheet parameters reflect tester guardbands and test setup variations.
8. This is a synchronous device. All addresses, data, and control lines must meet the specified setup and hold times for all latching clock edges.



AC TEST CONDITIONS

- Input pulse levels 0.25V to 1.25V
- Input rise and fall times 0.7ns
- Input timing reference levels 0.75V
- Output reference levels V_{DDQ}/2
- Z_Q for 50Ω impedance 250Ω
- Output load See Figure 5

Figure 5
Output Load Equivalent

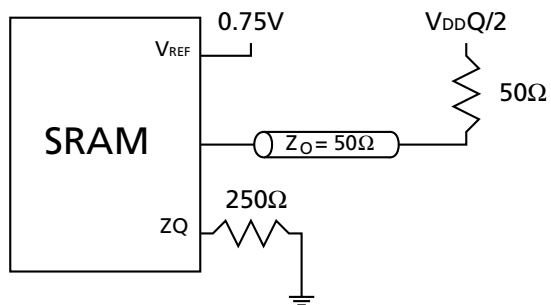
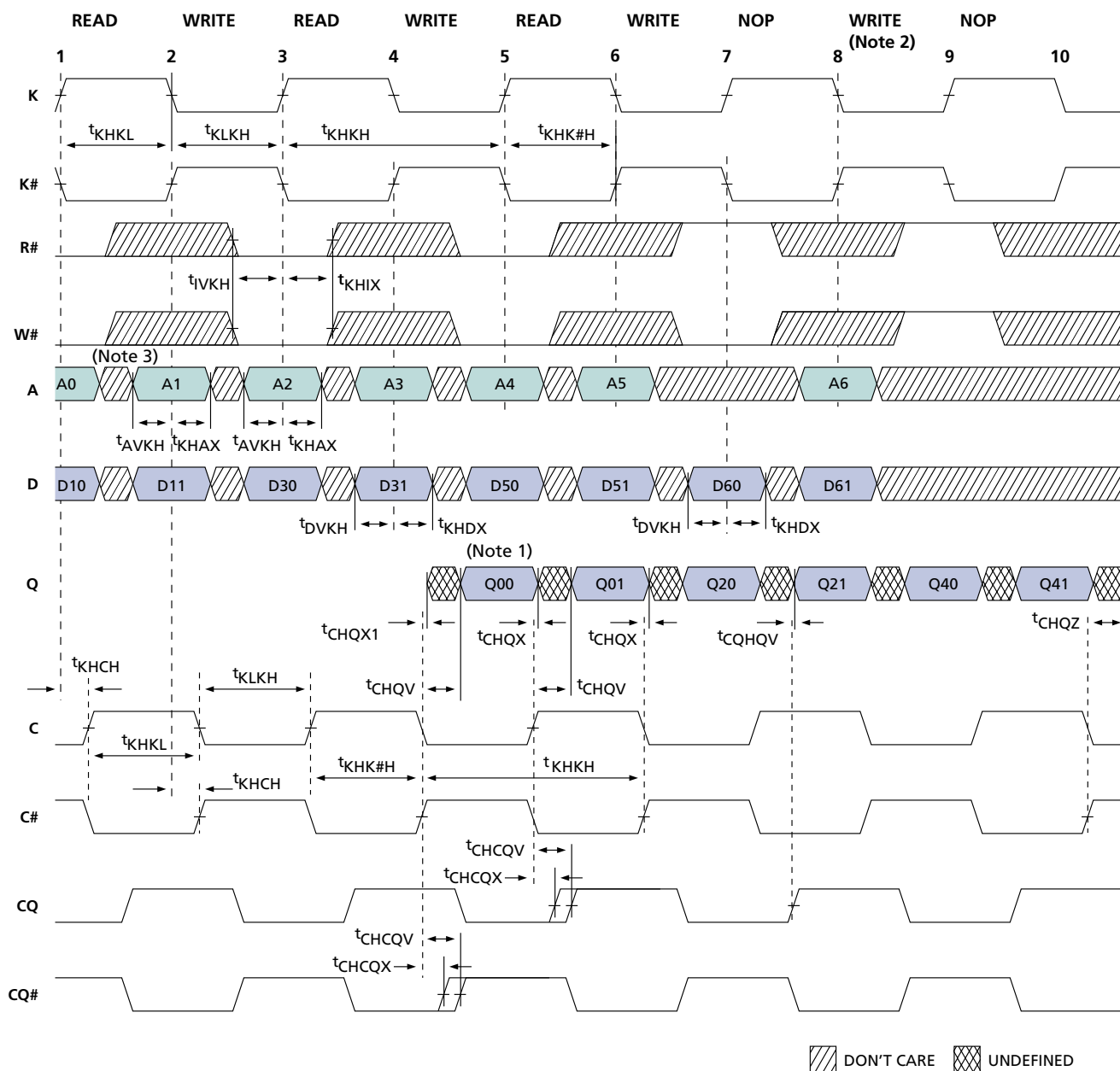



Figure 6
READ/WRITE Timing³



NOTE:

1. Q00 refers to output from address A0. Q01 refers to output from the next internal burst address following A0, i.e., A0 + 1.
2. Outputs are disabled (High-Z) one clock cycle after a NOP.
3. In this example, if address A0 = A1, then data Q00 = D10, Q01 = D11. Write data is forwarded immediately as read results.



IEEE 1149.1 SERIAL BOUNDARY SCAN (JTAG)

The QDR SRAM incorporates a serial boundary scan test access port (TAP). This port operates in accordance with IEEE Standard 1149.1-2001. The TAP operates using JEDEC-standard 1.8V I/O logic levels.

The SRAM contains a TAP controller, instruction register, boundary scan register, bypass register, and ID register.

Disabling the JTAG Feature

It is possible to operate the SRAM without using the JTAG feature. To disable the TAP controller, TCK must be tied LOW (V_{SS}) to prevent clocking of the device. TDI and TMS are internally pulled up and may be unconnected. Alternately, they may be connected to V_{DD} through a pull-up resistor. TDO should be left unconnected. Upon power-up, the device will come up in a reset state, which will not interfere with the operation of the device.

TEST ACCESS PORT (TAP)

Test Clock (TCK)

The test clock is used only with the TAP controller. All inputs are captured on the rising edge of TCK. All outputs are driven from the falling edge of TCK.

Test MODE SELECT (TMS)

The TMS input is used to give commands to the TAP controller and is sampled on the rising edge of TCK. It is allowable to leave this ball unconnected if the TAP is not used. The ball is pulled up internally, resulting in a logic HIGH level.

Figure 7
TAP Controller State Diagram

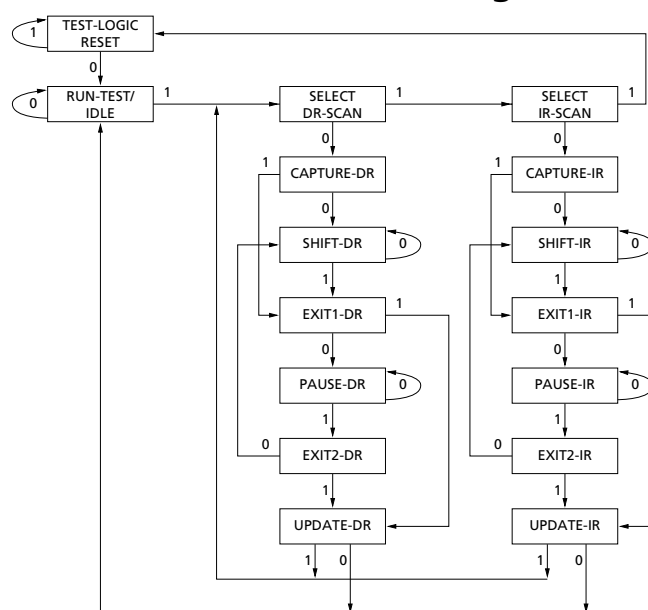

NOTE:

The 0 or 1 next to each state represents the value of TMS at the rising edge of TCK.

Test Data-In (TDI)

The TDI ball is used to serially input information into the registers and can be connected to the input of any of the registers. The register between TDI and TDO is chosen by the instruction that is loaded into the TAP instruction register. For information on loading the instruction register, see Figure 7. TDI is internally pulled up and can be unconnected if the TAP is unused in an application. TDI is connected to the most-significant bit (MSB) of any register, as illustrated in Figure 8.

Test Data-Out (TDO)

The TDO output ball is used to serially clock data-out from the registers. The output is active depending upon the current state of the TAP state machine. (See Figure 7.) The output changes on the falling edge of TCK. TDO is connected to the least-significant bit (LSB) of any register, as depicted in Figure 8.



Figure 8
TAP Controller Block Diagram

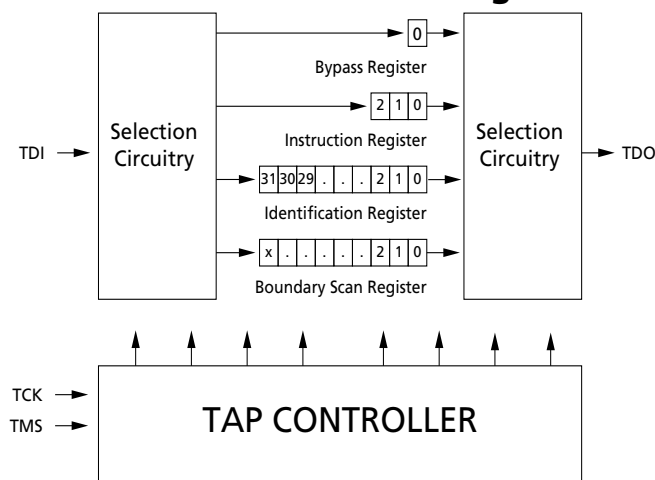

NOTE:

X = 108 for all configurations.

Performing a TAP RESET

A RESET is performed by forcing TMS HIGH (V_{DD}) for five rising edges of TCK. This RESET does not affect the operation of the SRAM and may be performed while the SRAM is operating.

At power-up, the TAP is reset internally to ensure that TDO comes up in a High-Z state.

TAP REGISTERS

Registers are connected between the TDI and TDO balls and allow data to be scanned into and out of the SRAM test circuitry. Only one register can be selected at a time through the instruction register. Data is serially loaded into the TDI ball on the rising edge of TCK. Data is output on the TDO ball on the falling edge of TCK.

Instruction Register

Three-bit instructions can be serially loaded into the instruction register. This register is loaded when it is placed between the TDI and TDO balls as shown in Figure 8. Upon power-up, the instruction register is loaded with the IDCODE instruction. It is also loaded with the IDCODE instruction if the controller is placed in a reset state, as described in the previous section.

When the TAP controller is in the Capture-IR state, the two LSBs are loaded with a binary "01" pattern to allow for fault isolation of the board-level serial test data path.

Bypass Register

To save time when serially shifting data through registers, it is sometimes advantageous to skip certain chips. The bypass register is a single-bit register that can be placed between the TDI and TDO balls. This allows data to be shifted through the SRAM with minimal delay. The bypass register is set LOW (V_{SS}) when the BYPASS instruction is executed.

Boundary Scan Register

The boundary scan register is connected to all the input and bidirectional balls on the SRAM. Several no connect (NC) balls are also included in the scan register to reserve balls. The SRAM has a 109-bit-long register.

The boundary scan register is loaded with the contents of the RAM I/O ring when the TAP controller is in the Capture-DR state and is then placed between the TDI and TDO balls when the controller is moved to the Shift-DR state.

The Boundary Scan Order tables show the order in which the bits are connected. Each bit corresponds to one of the balls on the SRAM package. The MSB of the register is connected to TDI, and the LSB is connected to TDO.

Identification (ID) Register

The ID register is loaded with a vendor-specific, 32-bit code during the Capture-DR state when the IDCODE command is loaded in the instruction register. The IDCODE is hardwired into the SRAM and can be shifted out when the TAP controller is in the Shift-DR state. The ID register has a vendor code and other information described in the Identification Register Definitions table.

TAP INSTRUCTION SET

Overview

Eight different instructions are possible with the three-bit instruction register. All combinations are listed in the Instruction Codes table. Three of these instructions are listed as RESERVED and should not be used. The other five instructions are described below in detail.

The TAP controller used in this SRAM is fully compliant to the 1149.1 convention.

Instructions are loaded into the TAP controller during the Shift-IR state when the instruction register is placed between TDI and TDO. During this state, instructions are shifted through the instruction regis-



ter, and through the TDI and TDO balls. To execute the instruction once it is shifted in, the TAP controller needs to be moved into the Update-IR state.

EXTEST

The EXTEST instruction allows circuitry external to the component package to be tested. Boundary scan register cells at output balls are used to apply test vectors, while those at input balls capture test results. Typically, the first test vector to be applied using the EXTEST instruction will be shifted into the boundary scan register using the PRELOAD instruction. Thus, during the Update-IR state of EXTEST, the output drive is turned on and the PRELOAD data is driven onto the output pins.

IDCODE

The IDCODE instruction causes a vendor-specific, 32-bit code to be loaded into the instruction register. It also places the instruction register between the TDI and TDO balls and allows the IDCODE to be shifted out of the device when the TAP controller enters the Shift-DR state. The IDCODE instruction is loaded into the instruction register upon power-up or whenever the TAP controller is given a test logic reset state.

SAMPLE Z

The SAMPLE Z instruction causes the boundary scan register to be connected between the TDI and TDO balls when the TAP controller is in a Shift-DR state. It also places all SRAM outputs into a High-Z state.

SAMPLE/PRELOAD

When the SAMPLE/PRELOAD instruction is loaded into the instruction register and the TAP controller is in the Capture-DR state, a snapshot of data on the inputs and bidirectional balls is captured in the boundary scan register.

The user must be aware that the TAP controller clock can only operate at a frequency up to 10 MHz, while the SRAM clock operates more than an order of magnitude faster. Because there is a large difference in the clock frequencies, it is possible that during the Capture-DR state, an input or output will undergo a transition. The TAP may then try to capture a signal while in transition (metastable state). This will not harm the device, but there is no guarantee as to the value that will be captured. Repeatable results may not be possible.

To guarantee that the boundary scan register will capture the correct value of a signal, the SRAM signal must be stabilized long enough to meet the TAP controller's capture setup plus hold time (t_{CS} plus t_{CH}). The SRAM clock input might not be captured correctly if there is no way in a design to stop (or slow) the clock during a SAMPLE/PRELOAD instruction. If this is an issue, it is still possible to capture all other signals and simply ignore the value of the C and C#, and K and K#, captured in the boundary scan register.

Once the data is captured, it is possible to shift out the data by putting the TAP into the Shift-DR state. This places the boundary scan register between the TDI and TDO balls.

BYPASS

When the BYPASS instruction is loaded in the instruction register and the TAP is placed in a Shift-DR state, the bypass register is placed between the TDI and TDO balls. The advantage of the BYPASS instruction is that it shortens the boundary scan path when multiple devices are connected together on a board.

RESERVED

These instructions are not implemented but are reserved for future use. Do not use these instructions.



**Figure 9
TAP Timing**

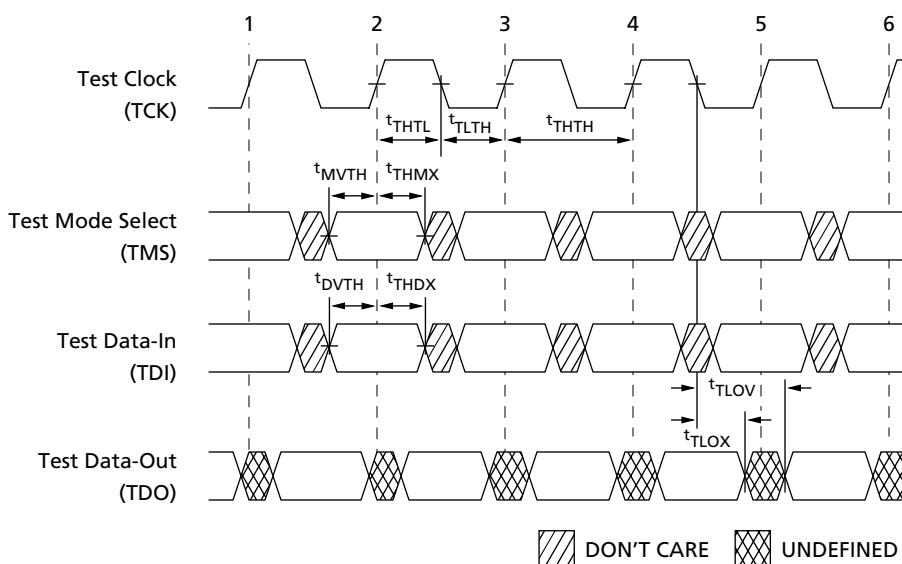

TAP DC ELECTRICAL CHARACTERISTICS^{1,2}

0°C ≤ T_A ≤ +70°C; +1.7V ≤ V_{DD} ≤ +1.9V

DESCRIPTION	SYMBOL	MIN	MAX	UNITS
Clock				
Clock cycle time	t _{THTH}	100		ns
Clock frequency	f _{TF}		10	MHz
Clock HIGH time	t _{THTL}	40		ns
Clock LOW time	t _{TLTH}	40		ns
Output Times				
TCK LOW to TDO unknown	t _{TLOX}	0		ns
TCK LOW to TDO valid	t _{TLOV}		20	ns
TDI valid to TCK HIGH	t _{DVTH}	10		ns
TCK HIGH to TDI invalid	t _{THDX}	10		ns
Setup Times				
TMS setup	t _{MVTH}	10		ns
Capture setup	t _{CS}	10		ns
Hold Times				
TMS hold	t _{THMX}	10		ns
Capture hold	t _{CH}	10		ns

NOTE:

1. t_{CS} and t_{CH} refer to the setup and hold time requirements of latching data from the boundary scan register.
2. Test conditions are specified using the load in Figure 10.



TAP AC TEST CONDITIONS

Input pulse levels V_{SS} to 1.8V
 Input rise and fall times 1ns
 Input timing reference levels 0.9V
 Output reference levels 0.9V
 Test load termination supply voltage 0.9V

Figure 10
TAP AC Output Load Equivalent

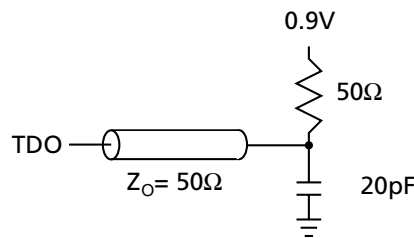

TAP DC ELECTRICAL CHARACTERISTICS AND OPERATING CONDITIONS

0°C ≤ T_A ≤ +70°C; +1.7V ≤ V_{DD} ≤ +1.9V unless otherwise noted

DESCRIPTION	CONDITIONS	SYMBOL	MIN	MAX	UNITS	NOTES
Input High (Logic 1) Voltage ^{1,2}		V _{IH}	1.3	V _{DD} + 0.3	V	1, 2
Input Low (Logic 0) Voltage ^{1,2}		V _{IL}	-0.3	0.5	V	1, 2
Input Leakage Current	0V ≤ V _{IN} ≤ V _{DD}	I _{LI}	-5.0	5.0	μA	
Output Leakage Current	Output(s) disabled, 0V ≤ V _{IN} ≤ V _{DDQ} (DQx)	I _{LO}	-5.0	5.0	μA	
Output Low Voltage ¹	I _{OLC} = 100μA	V _{OL1}		0.2	V	1
Output Low Voltage ¹	I _{OLT} = 2mA	V _{OL2}		0.4	V	1
Output High Voltage ¹	I _{OHC} = -100μA	V _{OH1}	1.6		V	1
Output High Voltage ¹	I _{OHT} = -2mA	V _{OH1}	1.4		V	1

NOTE:

1. All voltages referenced to V_{SS} (GND).
2. Overshoot: V_{IH}(AC) ≤ V_{DD} + 0.7V for t ≤ ¹t_{KHKH}/2
 Undershoot: V_{IL}(AC) ≥ -0.5V for t ≤ ¹t_{KHKH}/2
 Power-up: V_{IH} ≤ V_{DDQ} + 0.3V and V_{DD} ≤ +1.7V and V_{DDQ} ≤ 1.4V for t ≤ 200ms
 During normal operation, V_{DDQ} must not exceed V_{DD}. Control input signals (R#, W#, etc.) may not have pulse widths less than ¹t_{KHKL} (MIN) or operate at frequencies exceeding ¹f_{KF} (MAX).



IDENTIFICATION REGISTER DEFINITIONS

INSTRUCTION FIELD	ALL DEVICES	DESCRIPTION
REVISION NUMBER (31:28)	000	Version number.
DEVICE ID (28:12)	00def0Wx0t0q0b0s0	def = 001 for 36Mb density wx = 11 for x36, 10 for x18, 00 for x9, and 01 for x8 t = 1 for DLL version, 0 for non-DLL version q = 1 for QDR, 0 for DDR b = 1 for four-word burst, 0 for two-word burst s = 1 for separate I/O, 0 for common I/O
MICRON JEDEC ID CODE (11:1)	00000101100	Allows unique identification of SRAM vendor.
ID Register Presence Indicator (0)	1	Indicates the presence of an ID register.

SCAN REGISTER SIZES

REGISTER NAME	BIT SIZE (x18)
Instruction	3
Bypass	1
ID	32
Boundary Scan	109

INSTRUCTION CODES

INSTRUCTION	CODE	DESCRIPTION
EXTEST ^{1, 2}	000	Captures I/O ring contents. Places the boundary scan register between TDI and TDO.
IDCODE	001	Loads the ID register with the vendor ID code and places the register between TDI and TDO. This operation does not affect SRAM operations.
SAMPLE Z	010	Captures I/O ring contents. Places the boundary scan register between TDI and TDO. Forces all SRAM output drivers to a High-Z state.
RESERVED	011	Do Not Use: This instruction is reserved for future use.
SAMPLE/PRELOAD	100	Captures I/O ring contents. Places the boundary scan register between TDI and TDO.
RESERVED	101	Do Not Use: This instruction is reserved for future use.
RESERVED	110	Do Not Use: This instruction is reserved for future use.
BYPASS	111	Places the bypass register between TDI and TDO. This operation does not affect SRAM operations.

NOTE:

1. Data in output register is not guaranteed if EXTEST instruction is loaded.
2. After performing EXTEST, power-up conditions are required in order to return part to normal operation.

BOUNDARY SCAN (EXIT) ORDER

BIT#	FBGA BALL
1	6R
2	6P
3	6N
4	7P
5	7N
6	7R
7	8R
8	8P
9	9R
10	11P
11	10P
12	10N
13	9P
14	10M
15	11N
16	9M
17	9N
18	11L
19	11M
20	9L
21	10L
22	11K
23	10K
24	9J
25	9K
26	10J
27	11J
28	11H
29	10G
30	9G
31	11F
32	11G
33	9F
34	10F
35	11E
36	10E

BIT#	FBGA BALL
37	10D
38	9E
39	10C
40	11D
41	9C
42	9D
43	11B
44	11C
45	9B
46	10B
47	11A
48	10A
49	9A
50	8B
51	7C
52	6C
53	8A
54	7A
55	7B
56	6B
57	6A
58	5B
59	5A
60	4A
61	5C
62	4B
63	3A
64	2A
65	1A
66	2B
67	3B
68	1C
69	1B
70	3D
71	3C
72	1D

BIT#	FBGA BALL
73	2C
74	3E
75	2D
76	2E
77	1E
78	2F
79	3F
80	1G
81	1F
82	3G
83	2G
84	1H
85	1J
86	2J
87	3K
88	3J
89	2K
90	1K
91	2L
92	3L
93	1M
94	1L
95	3N
96	3M
97	1N
98	2M
99	3P
100	2N
101	2P
102	1P
103	3R
104	4R
105	4P
106	5P
107	5N
108	5R
109	INTERNAL

NOTE:

For NC balls in the range of 1B-1P, 2B-2P, 3B-3P, 9B-9P, 10B-10P, and 11B-11P, a logic zero will be read from the chain. All other NC balls will appear in the scan chain as the logic level present on the ball site.



Figure 11
165-Ball FBGA

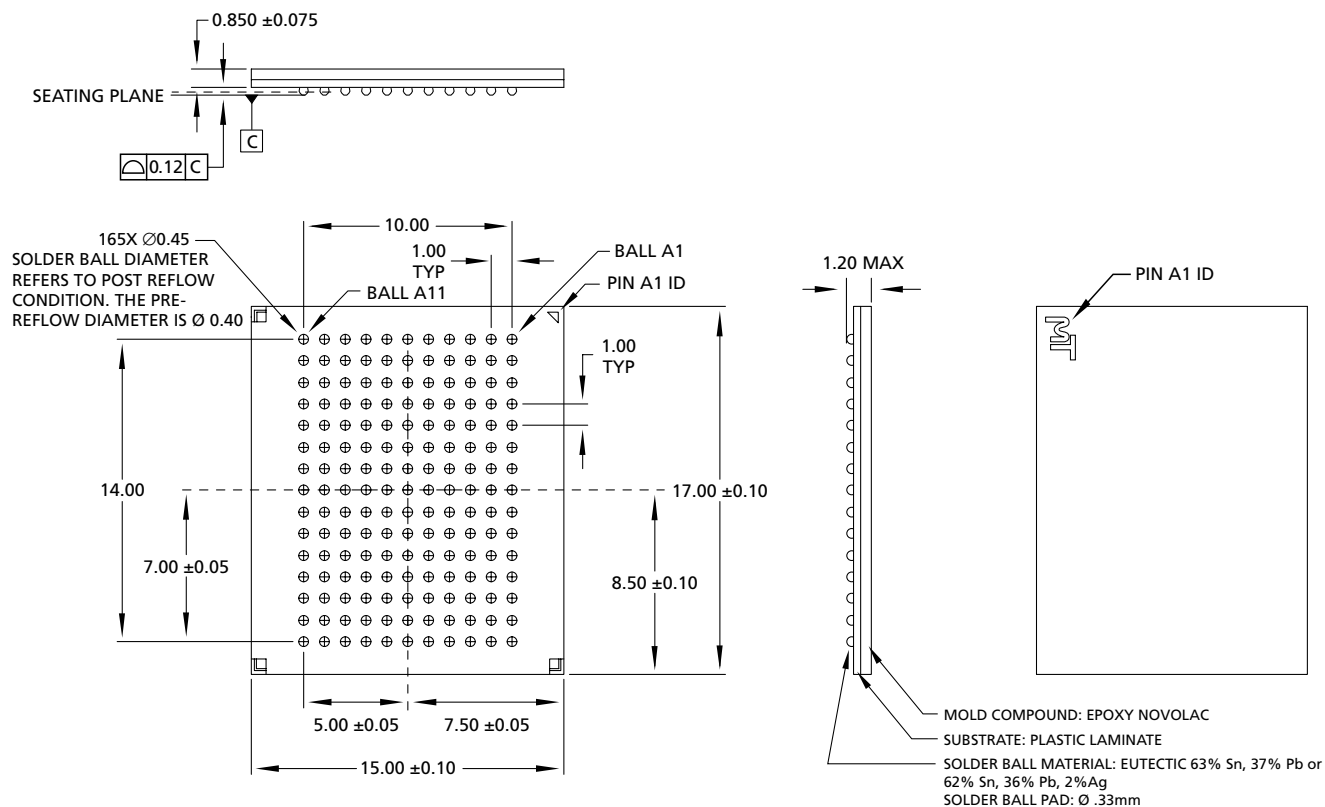

NOTE:

1. All dimensions are in millimeters.

DATA SHEET DESIGNATION

Advance: This data sheet contains initial descriptions of products still under development.



8000 S. Federal Way, P.O. Box 6, Boise, ID 83707-0006, Tel: 208-368-3900

E-mail: prodmktg@micron.com, Internet: <http://www.micron.com>, Customer Comment Line: 800-932-4992

Micron and the M logo are registered trademarks and SyncBurst and the Micron logo are trademarks of Micron Technology, Inc. QDR RAMs and Quad Data Rate RAMs comprise a new family of products developed by Cypress Semiconductor, IDT, Micron Technology, Inc., NEC, and Samsung.



REVISION HISTORY

- Rev. A, Pub. 9/02.....9/02
 - New ADVANCE data sheet