

## VOLTAGE REGULATION STEP-UP CHARGE PUMP DC-DC CONVERTER

## S-8821 Series

The S-8821 series is a CMOS step-up charge pump DC-DC converter with a voltage regulation function. The S-8821 series consists of an oscillation circuit, a controller, a reference voltage circuit, an error amplifier circuit, and an output switching transistor, and can regulate the output voltage by PFM control. Since small ceramic capacitors can be used for the pump capacitor, input capacitor, and output capacitor, the mounting area can be minimized.

### ■ Features

- Step-up PFM control CMOS charge pump
- Power supply voltage: 1.6 to 5.0 V
- Output voltage: 2.5 to 5.5 V, selectable in 0.1 V steps.
- Output voltage accuracy:  $\pm 2\%$  max.
- Built-in soft start circuit: 1.0 ms typ.
- Output current: 25 mA ( $V_{IN} = (V_{OUT(S)} \times 0.80)$  V)
- Oscillation frequency: 1.0 MHz typ.
- ON/OFF function: During standby: 1  $\mu$ A max.
- Ultra-small package: SOT-23-6W
- Lead-free products

### ■ Applications

- Lithium ion battery driven applications
- Local power supply
- Power supply for white LED display backlights

### ■ Packages

Package Name	Drawing Code		
	Package	Tape	Reel
SOT-23-6W	MP006-B	MP006-B	MP006-B

■ Block Diagram

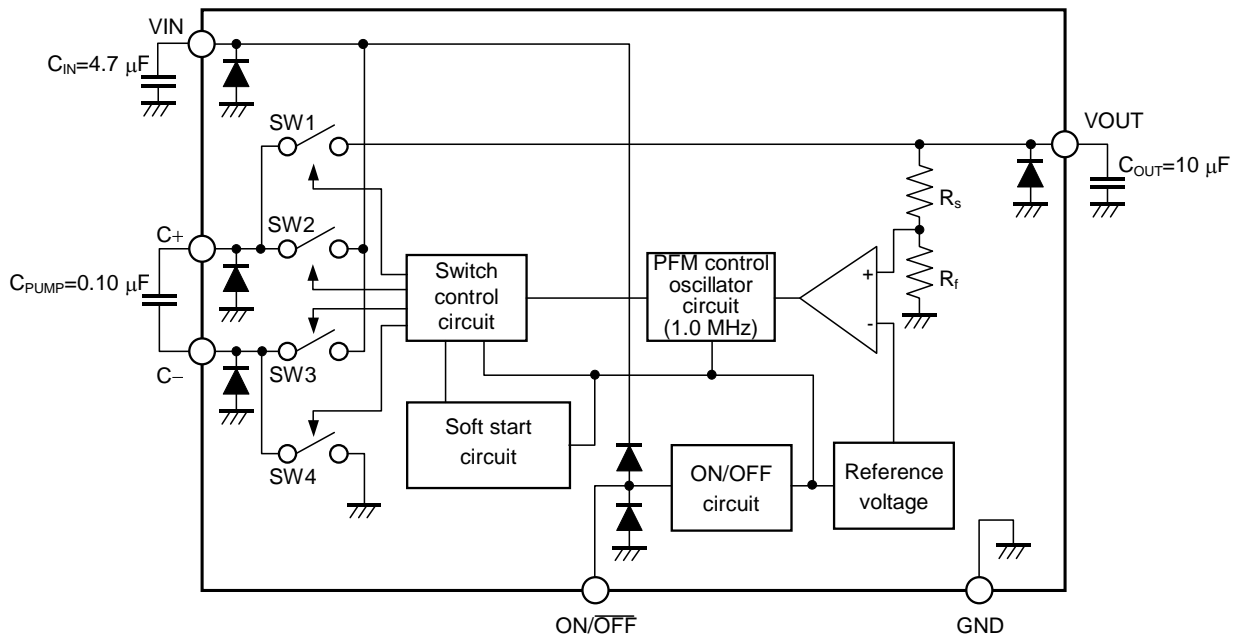
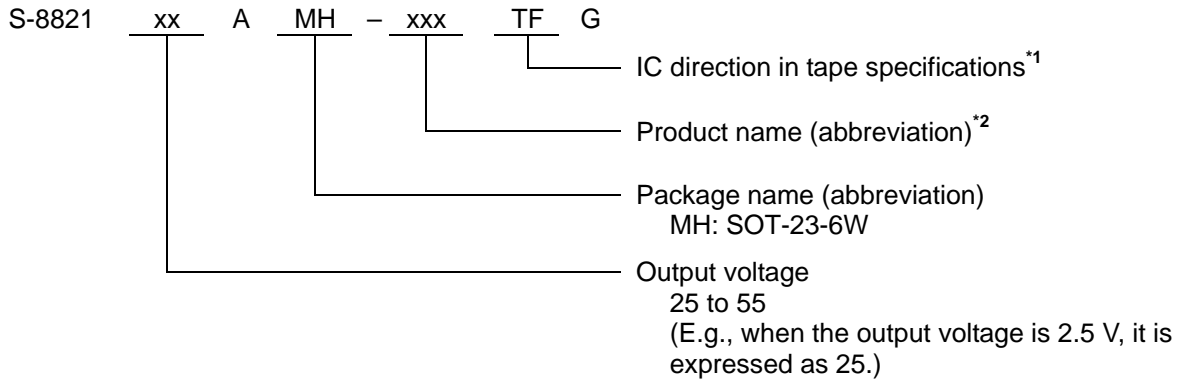

Figure 1

■ **Product Name Structure**

- The output voltage and packages for the S-8821 Series can be selected at the user’s request. Refer to the “Product name” for the meanings of the characters in the product name and “Product name list” for the full product names.

**1. Product name**



\*1. Refer to the taping specifications at the end of this book.

\*2. Refer to the product name list.

**2. Product name list**

**Table 1**

Output Voltage	SOT-23-6W
2.5 V	S-882125AMH-M2ATFG
3.0 V	S-882130AMH-M2FTFG
3.3 V	S-882133AMH-M2ITFG
3.5 V	S-882135AMH-M2KTFG
3.6 V	S-882136AMH-M2LTFG
4.0 V	S-882140AMH-M2PTFG
4.5 V	S-882145AMH-M2UTFG
5.0 V	S-882150AMH-M2ZTFG
5.2 V	S-882152AMH-M3BTFG
5.5 V	S-882155AMH-M3ETFG

**Remark** Contact the SII sales department for products with an output voltage other than those specified above.

■ **Pin Configurations**

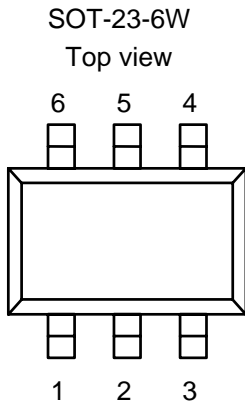

**Table 2**

Pin No.	Symbol	Pin Description
1	VIN	Voltage input pin
2	C+	Charge-pump pump capacitor connection pin (positive pin)
3	C-	Charge-pump pump capacitor connection pin (negative pin)
4	ON/OFF	Shutdown pin High level (H): normal operation (step-up) Low level (L) : step-up halt (all circuit halt)
5	GND	GND pin
6	VOUT	Voltage output pin

**Figure 2**

■ **Absolute Maximum Ratings**

**Table 3**

(Ta=25°C unless otherwise specified)

Items	Symbols	Absolute Maximum Ratings	Units
C+ pin voltage	V <sub>C+</sub>	V <sub>GND</sub> -0.3 to V <sub>GND</sub> +7.5	V
C- pin voltage	V <sub>C-</sub>	V <sub>GND</sub> -0.3 to V <sub>GND</sub> +7	V
VIN pin voltage	V <sub>IN</sub>	V <sub>GND</sub> -0.3 to V <sub>GND</sub> +5.5	V
VOU <sub>T</sub> pin voltage	V <sub>OUT</sub>	V <sub>GND</sub> -0.3 to V <sub>GND</sub> +7	V
ON/OFF pin voltage	V <sub>ON/OFF</sub>	V <sub>GND</sub> -0.3 to V <sub>IN</sub> +0.3	V
Power dissipation	P <sub>D</sub>	300 (When not mounted on board)	mW
		650*1	mW
Operating ambient temperature	T <sub>opr</sub>	-40 to +85	°C
Storage temperature	T <sub>stg</sub>	-40 to +125	°C

\*1. When mounted on board

[Mounted board]

- (1) Board size: 114.3 mm × 76.2 mm × t1.6 mm
- (2) Board name: JEDEC STANDARD51-7

**Caution** The absolute maximum ratings are rated values exceeding which the product could suffer physical damage. These values must therefore not be exceeded under any conditions.

**(1) When mounted on board**

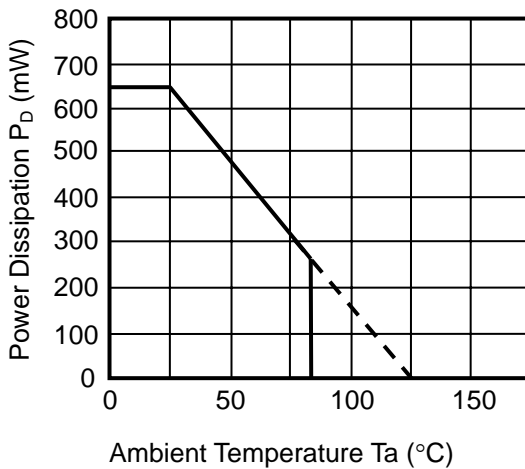

**(2) When not mounted on board**

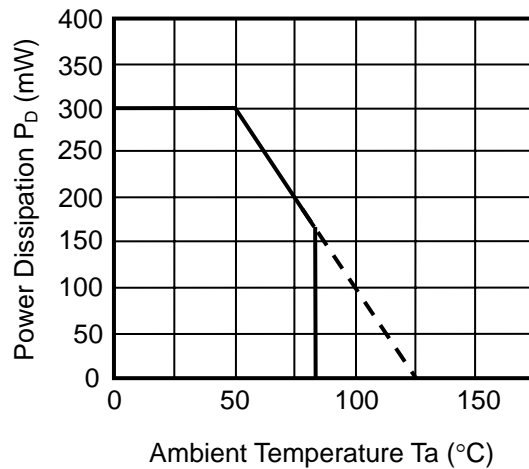

**Figure 3 Power Dissipation of Package**

■ **Electrical Characteristics**

**Table 4**

( $V_{IN}=(V_{OUT(S)} \times 0.60) V^{*1}$ ,  $T_a=25^{\circ}C$  unless otherwise specified)

Items	Symbols	Conditions	Min.	Typ.	Max.	Units	Test circuits
Operation input voltage	$V_{IN}$	$V_{OUT(S)} \leq 2.9 V$	1.6	—	5.0	V	2
		$V_{OUT(S)} > 2.9 V$	$V_{OUT(S)} \times 0.54$	—	5.0	V	2
Output voltage <sup>*2</sup>	$V_{OUT(E)}$	$I_{OUT}=10 mA$	$V_{OUT(S)} \times 0.98$	$V_{OUT(S)}$	$V_{OUT(S)} \times 1.02$	V	2
Output current <sup>*3</sup>	$I_{OUT}$	$V_{IN}=(V_{OUT(S)} \times 0.54) V^{*6}$	5	—	—	mA	2
		$V_{IN}=(V_{OUT(S)} \times 0.60) V^{*1}$	15	—	—	mA	2
		$V_{IN}=(V_{OUT(S)} \times 0.80) V$	25	—	—	mA	2
Line regulation	$\Delta V_{OUT1}$	$V_{IN}=(V_{OUT(S)} \times 0.60) V^{*1}$ to $(V_{OUT(S)} - 0.10) V$ , $I_{OUT}=10 mA$	—	50	100	mV	2
Load regulation	$\Delta V_{OUT2}$	$I_{OUT}=0.1 mA$ to $10 mA$	—	40	80	mV	2
Ripple voltage <sup>*4</sup>	$V_{RIP}$	$I_{OUT}=10 mA$	—	70	—	mV <sub>p-p</sub>	2
Maximum oscillation frequency	$f_{osc}$	$V_{OUT}=(V_{OUT(S)} \times 0.60) V$ , Measure waveform at C- pin	800	1000	1200	kHz	2
Efficiency <sup>*5</sup>	$\eta$	$V_{IN}=(V_{OUT(S)} \times 0.54) V$ , $V_{OUT(S)} \geq 3.0 V$ , $I_{OUT}=5 mA$	—	90	—	%	1
Operation consumption current	$I_{SS1}$	$V_{IN}=V_{OUT(S)}$ , $V_{OUT}=(V_{OUT(S)} + 0.5) V$	—	35	60	$\mu A$	2
Standby consumption current	$I_{SSS}$	$V_{IN}=(V_{OUT(S)} \times 0.54) V^{*6}$ to $5.0 V$ , $V_{ON/OFF}=0 V$	—	0.3	1.0	$\mu A$	1
ON/OFF pin input voltage (high level)	$V_{SH}$	$V_{IN}=(V_{OUT(S)} \times 0.54) V^{*6}$ to $5.0 V$	1.5	—	—	V	1
ON/OFF pin input voltage (low level)	$V_{SL}$	$V_{IN}=(V_{OUT(S)} \times 0.54) V^{*6}$ to $5.0 V$	—	—	0.3	V	1
ON/OFF pin input current (high level)	$I_{SH}$	$V_{IN}=(V_{OUT(S)} \times 0.54) V^{*6}$ to $5.0 V$	-0.1	—	0.1	$\mu A$	1
ON/OFF pin input current (low level)	$I_{SL}$	$V_{IN}=(V_{OUT(S)} \times 0.54) V^{*6}$ to $5.0 V$	-0.1	—	0.1	$\mu A$	1
Soft start time	$t_{SS}$	$I_{OUT}=10 mA$	0.2	1.0	4.0	ms	1

\*1. In case of  $V_{OUT} \leq 3.3 V$ ,  $V_{IN}=2.0 V$

\*2.  $V_{OUT(E)}$ : Actual output voltage  
 $V_{OUT(S)}$ : Specified output voltage

\*3. The output current at which the output voltage becomes 97 % of  $V_{OUT(E)}$  after gradually increasing the output current.

\*4. Design assurance

\*5. The ideal efficiency is indicated by the following expression.  
 Efficiency ( $\eta$ )= $(V_{OUT} \times I_{OUT}) / (2.0 \times V_{IN} \times I_{OUT})$

\*6. In case of  $V_{OUT} \leq 2.9 V$ ,  $V_{IN}=1.6 V$

■ Test Circuits

1.

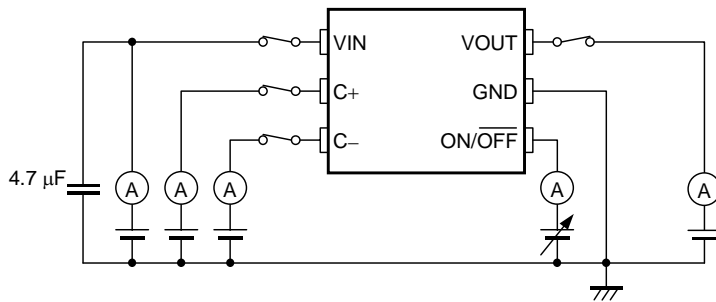

Figure 4

2.

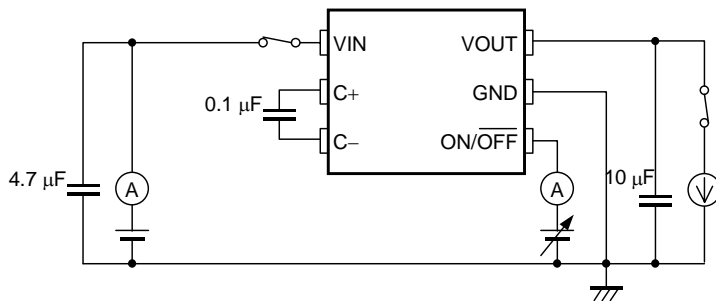

Figure 5

■ Operation

1. Basic operation

Figure 6 shows the block diagram of the S-8821 Series.

The S-8821 series controls the output voltage by using the pulse frequency modulation (PFM) method. The SW1 to SW4 switching transistors are switched ON/OFF with the clock generated by the internal oscillator circuit, and operates the step-up charge pump.

The output voltage is fed back and the voltage split by feedback resistances  $R_s$  and  $R_f$  and reference voltage ( $V_{ref}$ ) are compared by a comparator. This comparator signal is used to modulate the oscillation pulse frequency in order to keep the output voltage constant.

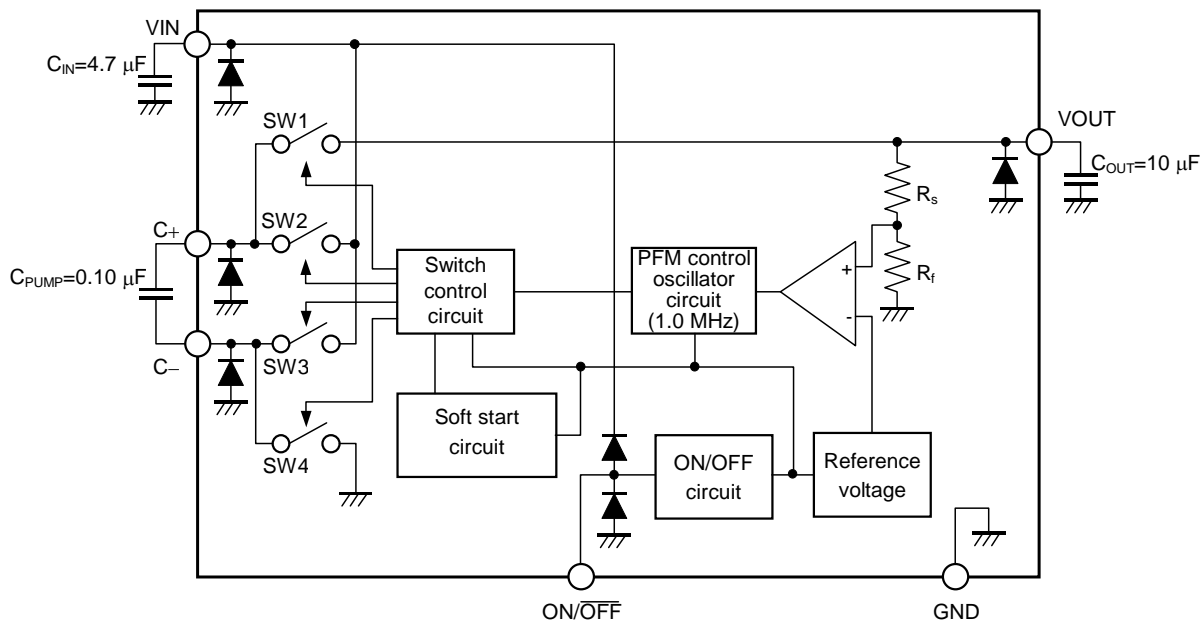

Figure 6



2. Step-up Charge Pump

The step-up charge pump steps up the voltage by switching ON/OFF of the SW1 to SW4 switching transistors.

First, in order to charge the pump capacitance ( $C_{PUMP}$ ), set SW1 to OFF, SW2 to ON, SW3 to OFF, and SW4 to ON (charge cycle). Following charging the electricity, in order to discharge the charged electricity to the output capacitance ( $C_{OUT}$ ), SW1 set the switches as to ON, SW2 to OFF, SW3 to ON, and SW4 to OFF (discharge cycle).

The input voltage can be stepped up to a constant voltage value by repeating this charge cycle and discharge cycle.

Figure 7 shows the charge cycle, and Figure 8 shows the discharge cycle.

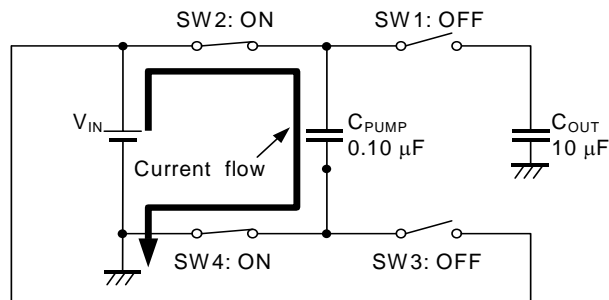

Figure 7

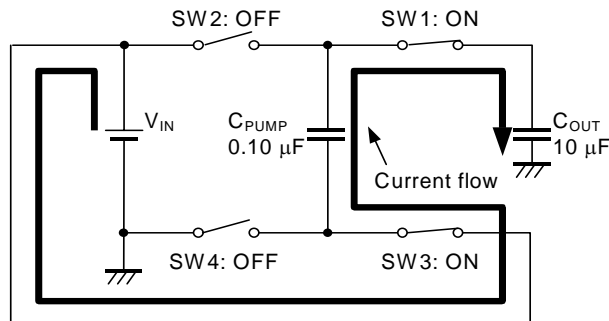

Figure 8

**3. Shutdown Pin (ON/OFF Pin)**

Setting the ON/OFF pin to the Low level ("L") causes the voltage of the VOUT pin to change to the GND level and simultaneously the operation of all the internal circuit to stop. At this time, the consumption current is largely reduced, to a level of approximately 0.3  $\mu$ A.

The structure of the ON/OFF pin is as shown in **Figure 9**. Since the ON/OFF pin is neither pulled down nor pulled up internally, do not use it in the floating state.

When the ON/OFF pin is not used, connect it to the VIN pin.

**Table 5**

ON/OFF pin	Internal circuit	VOUT pin voltage
"H": Power on	Operating	Set value
"L": Power off	Stop	V <sub>GND</sub> level

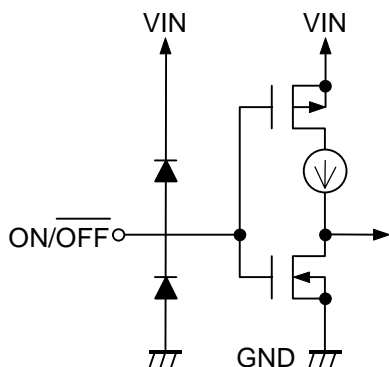

**Figure 9**

**4. Soft Start Function**

The S-8821 Series features a built-in soft start circuit. Upon power application or when the ON/OFF pin is switched from "L" to "H", the output voltage gradually rises over the soft start time, and the output current is gradually output as a result. This soft start function reduces the input current rush.

## ■ External Capacitor Selection

### 1. Input and Output Capacitors ( $C_{IN}$ , $C_{OUT}$ )

The input capacitor ( $C_{IN}$ ) lowers the power supply impedance and averages the input current.

The  $C_{IN}$  value is selected according to the impedance of the power supply that is used. Select a ceramic capacitor with a small equivalent series resistance (ESR). Although this figure varies according to the impedance of the power supply that is used as well as the load current value, it is generally in the range of 4.7  $\mu\text{F}$  to 10  $\mu\text{F}$ .

For the output capacitor ( $C_{OUT}$ ), select a ceramic capacitor with a small ESR for smoothing the ripple voltage. A value of 10  $\mu\text{F}$  is recommended for the capacitance value. Use of a capacitor with a capacitance lower than 10  $\mu\text{F}$  results in a larger ripple voltage. Conversely, use of a capacitor with a capacitance greater than 10  $\mu\text{F}$  results in the output voltage not being able to rise up to setting value and the impossibility to obtain the desired output current.

### 2. Pump Capacitor ( $C_{PUMP}$ )

The pump capacitor ( $C_{PUMP}$ ) is required for stepping up the voltage. Select a ceramic capacitor with a small ESR. A capacitance value of 0.10  $\mu\text{F}$  is recommended. Use of a capacitor with a capacitance greater than 0.10  $\mu\text{F}$  results in a larger ripple voltage. Conversely, use of a capacitor with a capacitance lower than 0.10  $\mu\text{F}$  results in the output voltage not being able to raise up to setting value and the impossibility to obtain the desired output current.

## ■ Precautions

- Regarding the wiring to the VIN pin, VOUT pin, C+ pin, C– pin and GND pin, be careful to perform pattern wiring so as to obtain low impedance.
- Always connect a capacitor to the VOUT pin, C+ pin, and C– pin.
- Connect C<sub>IN</sub> and C<sub>OUT</sub> in the vicinity of the IC and sufficiently strengthen the wiring for GND pin and VIN pin in order to lower the impedance of the wiring resistance, etc. High impedance may cause unstable operation.  
Moreover, in selecting C<sub>IN</sub> and C<sub>OUT</sub>, perform a full evaluation of the actual usage conditions.
- Connect C<sub>PUMP</sub> in the vicinity of the IC and sufficiently strengthen the wiring for the C+ pin and C– pin in order to lower the impedance of the wiring resistance, etc. High impedance may cause instable operation.  
Moreover, in selecting C<sub>PUMP</sub>, perform a full evaluation of the actual usage conditions.
- The ON/ $\overline{\text{OFF}}$  pin is configured as shown in **Figure 9** and is neither pulled up or down internally, so do not use this pin in a floating state. When not using the ON/ $\overline{\text{OFF}}$  pin, connect it to the VIN pin.  
Moreover, please do not apply voltage higher than VIN + 0.3 V to an ON/ $\overline{\text{OFF}}$  pin. Current flows for a VIN pin through the protection diode inside IC.
- Since this IC consists of double step-up circuits, it cannot set more than twice voltage of V<sub>IN</sub> to V<sub>OUT(S)</sub>.
- Be careful about the usage conditions for the input/output voltages and output current to make sure that dissipation within the IC does not exceed the allowable power dissipation of the package.  
For reference, the calculation of the power consumption in this IC is shown below.  
$$P_D = (V_{IN} \times 2.0 - V_{OUT}) \times (I_{OUT})$$
  
Reference: V<sub>IN</sub>=4.2 V, V<sub>OUT</sub>=5.5 V, I<sub>OUT</sub>=10 mA  
$$P_D = (4.2 \times 2.0 - 5.5) \times 0.010 = 29 \text{ mW}$$
- Since the information described herein is subject to change without notice, confirm that this is the latest one before using.
- Do not apply an electrostatic discharge to this IC that exceeds the performance ratings of the built-in electrostatic protection circuit.
- SII claims no responsibility for any and all disputes arising out of or in connection with any infringement of the products including this IC upon patents owned by a third party.

■ Characteristics (Typical Data)

(1) Output voltage vs. Operation input voltage

S-882133A

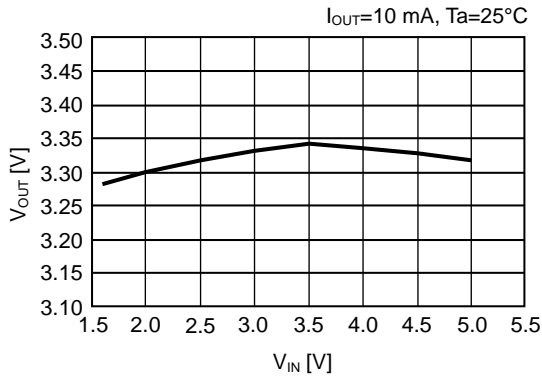

S-882150A

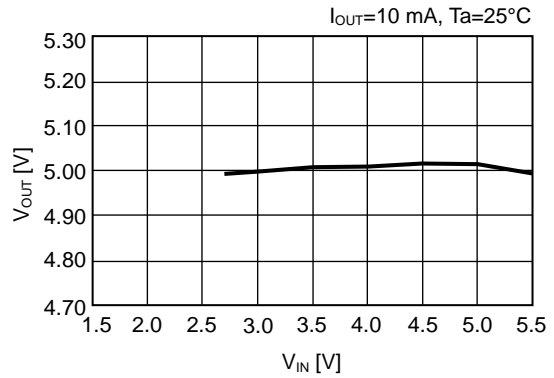

(2) Output voltage vs. Output current

S-882133A

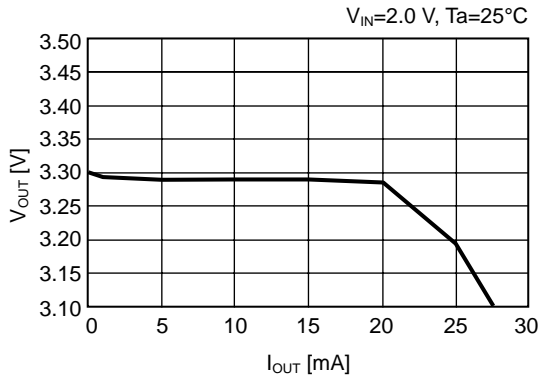

S-882150A

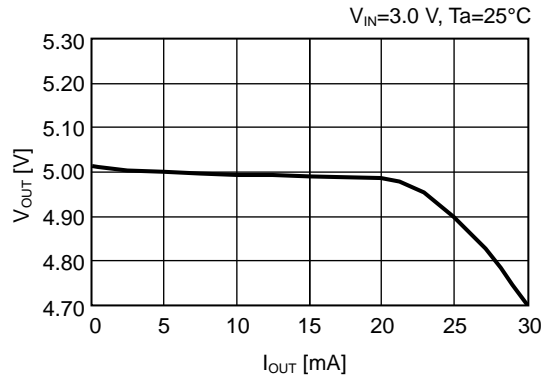

(3) Operation consumption vs. Operation input voltage

S-882133A

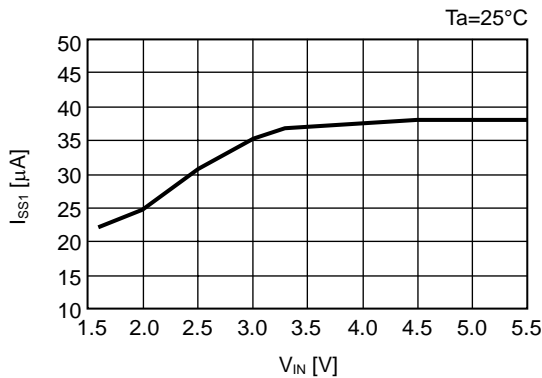

S-882150A

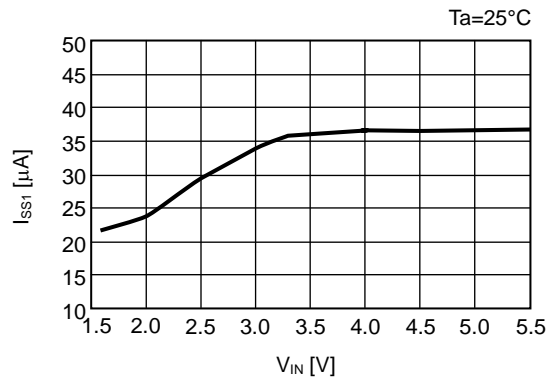

**(4) Ripple voltage vs. Operation input voltage**

S-882133A

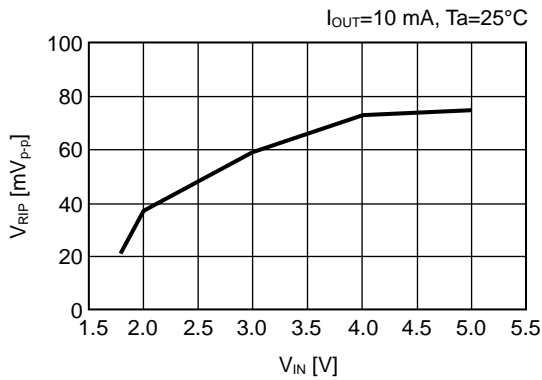

S-882150A

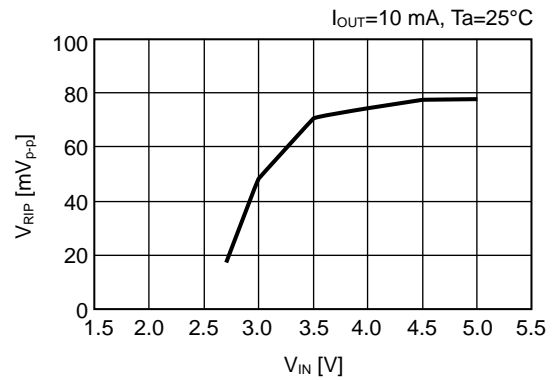

**(5) Efficiency\*1 vs. Operation input voltage**

S-882133A

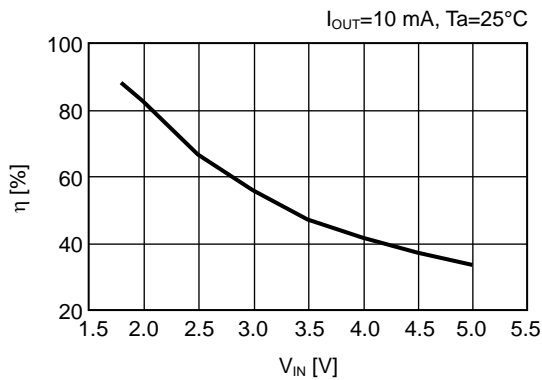

S-882150A

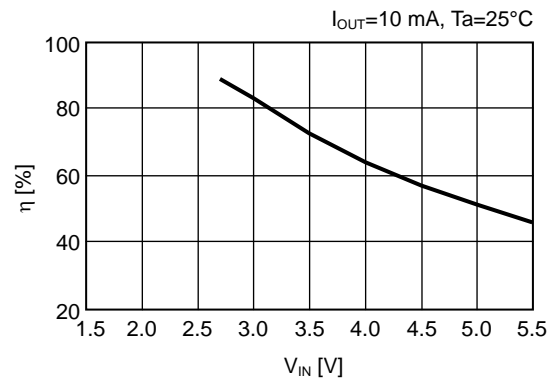

\*1. The ideal efficiency is indicated by the following expression.  
 Efficiency (η) = (V<sub>OUT</sub> × I<sub>OUT</sub>) / (2.0 × V<sub>IN</sub> × I<sub>OUT</sub>)

**(6) Maximum oscillation frequency vs. Operation input voltage**

S-882133A

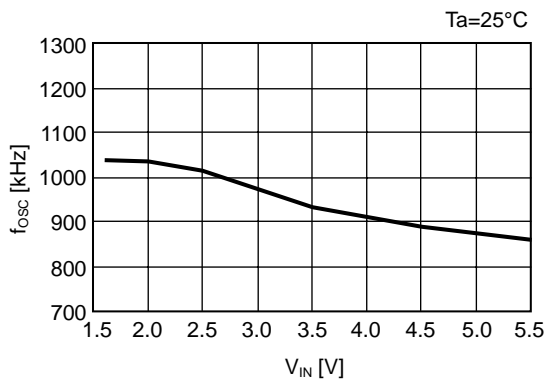

S-882150A

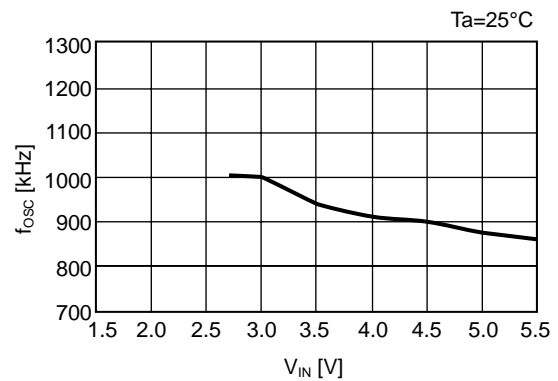

**VOLTAGE REGULATION STEP-UP CHARGE PUMP DC-DC CONVERTER**  
**S-8821 Series**

Rev.3.1\_00

**(7) Load fluctuation**

S-882133A

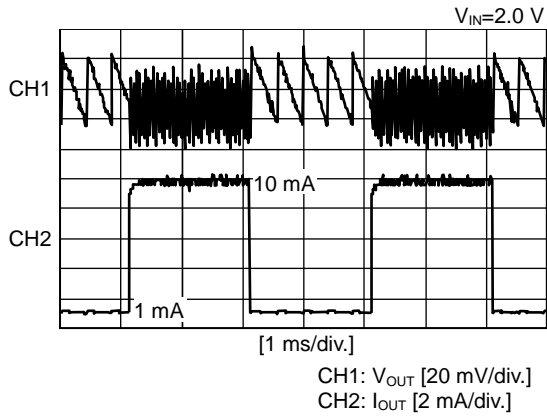

S-882150A

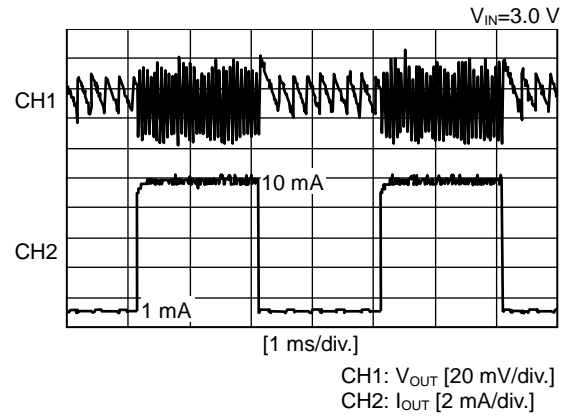

**(8) Input voltage fluctuation**

S-882133A

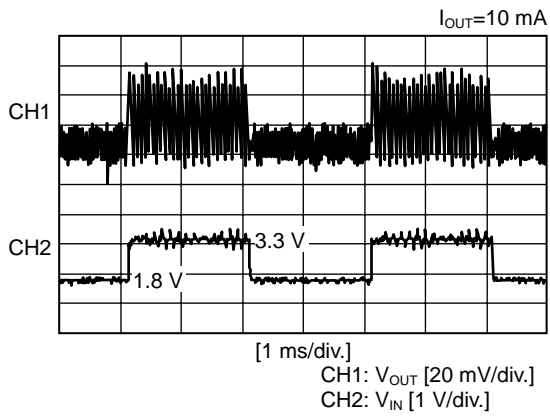

S-882150A

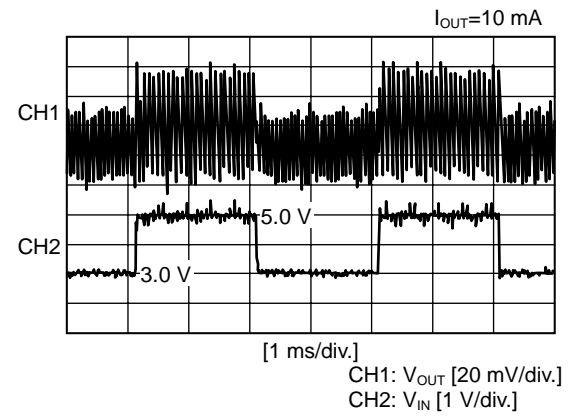

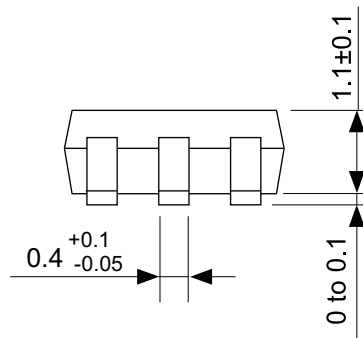
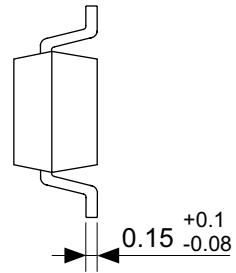
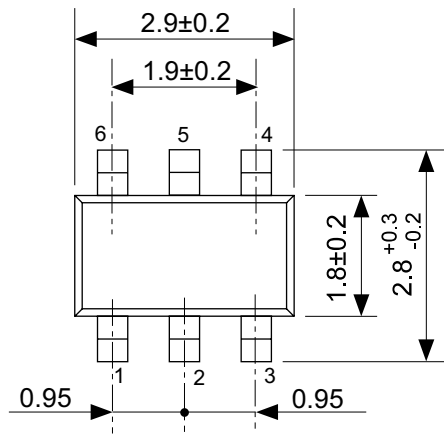

No. MP006-B-P-SD-1.0

TITLE	SOT236-B-PKG Dimensions
No.	MP006-B-P-SD-1.0
SCALE	
UNIT	mm
Seiko Instruments Inc.	



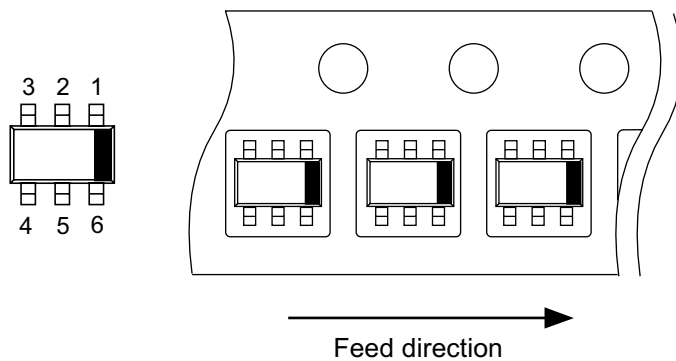
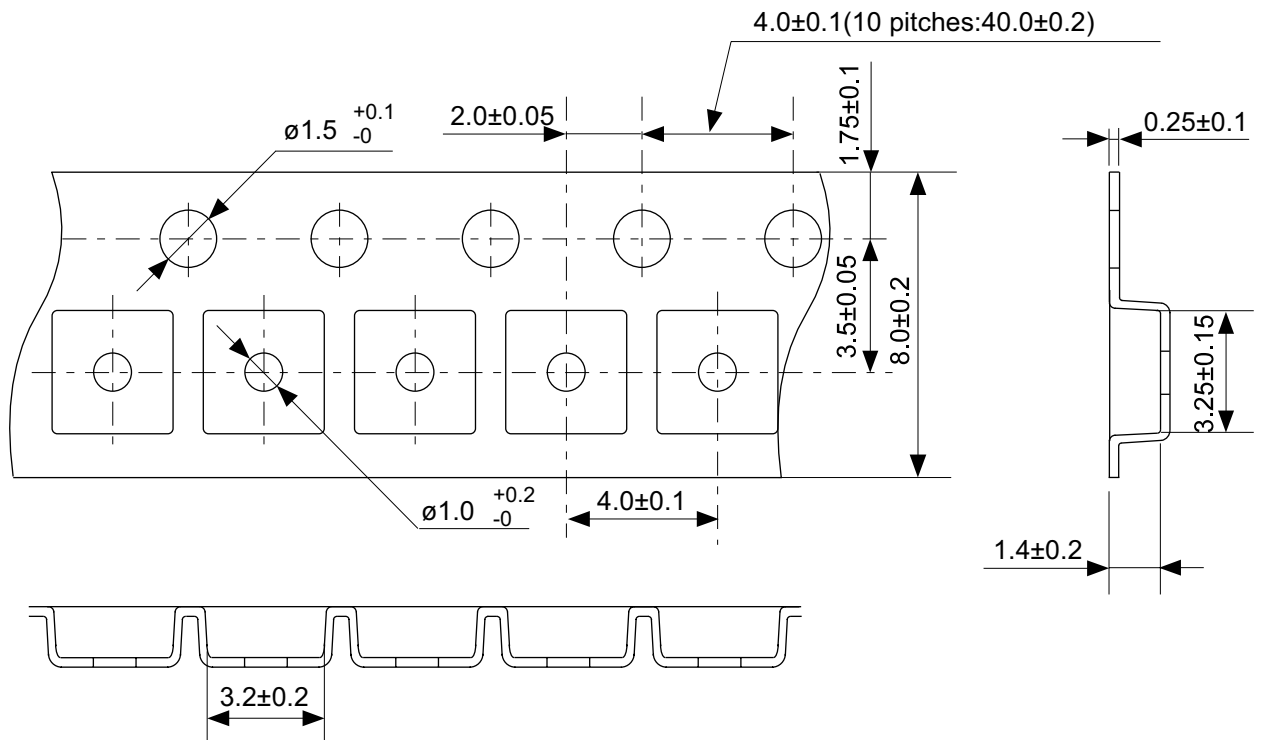

No. MP006-B-C-SD-1.0

TITLE	SOT236-B-Carrier Tape
No.	MP006-B-C-SD-1.0
SCALE	
UNIT	mm
Seiko Instruments Inc.	

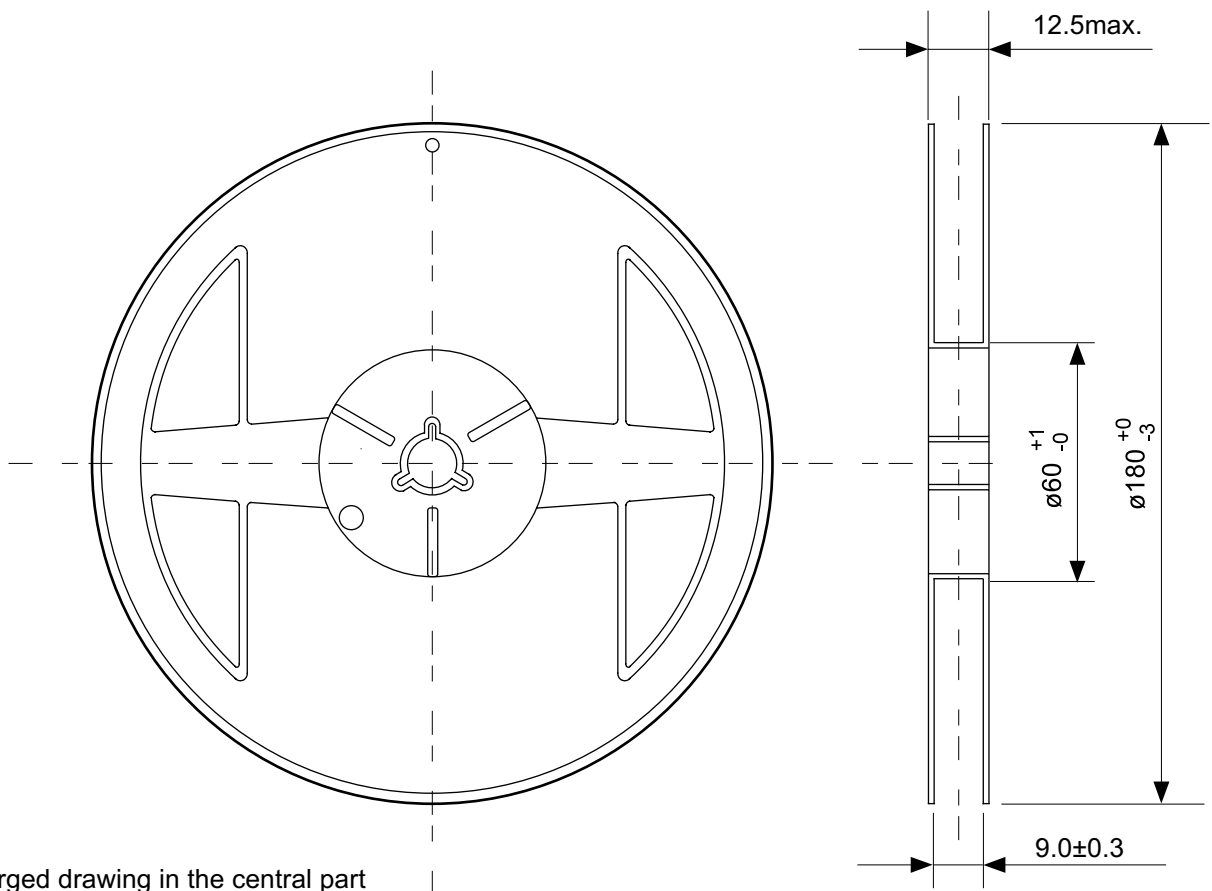

Enlarged drawing in the central part

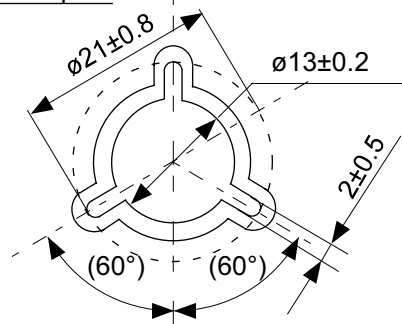

No. MP006-B-R-SD-1.0

TITLE	SOT236-B-Reel		
No.	MP006-B-R-SD-1.0		
SCALE		QTY	3,000
UNIT	mm		
Seiko Instruments Inc.			

- The information described herein is subject to change without notice.
- Seiko Instruments Inc. is not responsible for any problems caused by circuits or diagrams described herein whose related industrial properties, patents, or other rights belong to third parties. The application circuit examples explain typical applications of the products, and do not guarantee the success of any specific mass-production design.
- When the products described herein are regulated products subject to the Wassenaar Arrangement or other agreements, they may not be exported without authorization from the appropriate governmental authority.
- Use of the information described herein for other purposes and/or reproduction or copying without the express permission of Seiko Instruments Inc. is strictly prohibited.
- The products described herein cannot be used as part of any device or equipment affecting the human body, such as exercise equipment, medical equipment, security systems, gas equipment, or any apparatus installed in airplanes and other vehicles, without prior written permission of Seiko Instruments Inc.
- Although Seiko Instruments Inc. exerts the greatest possible effort to ensure high quality and reliability, the failure or malfunction of semiconductor products may occur. The user of these products should therefore give thorough consideration to safety design, including redundancy, fire-prevention measures, and malfunction prevention, to prevent any accidents, fires, or community damage that may ensue.