

STEP-UP, FOR LCD BIAS SUPPLY, 1-CHANNEL SWITCHING REGULATOR

S-8330/8331 Series

The S-8330/8331 Series is a CMOS PWM-control step-up switching regulator which mainly consists of a reference voltage source, an oscillation circuit, a power MOS FET (for S-8330 Series), and an error amplifier. The output voltage can adjust by built-in Electric volume circuit, and equip with shutdown function. The S-8330 Series is low current consumption because of CMOS structure, and a step-up switching regulator constructed by externally connecting only a coil, a capacitor and a diode. This feature, along with its 8-Pin SSOP package and a few external components, makes the S-8330 Series ideal for LCD bias generators of portable equipment. For applications requiring a high output current, products used with an external transistor (S-8331 Series) are also available.

■ Features

- Maximum output voltage: 20 V to 30 V (2 V step)
12 V range can be adjusted by electric volume
- Output voltage accuracy : $\pm 2.4\%$
- Output current: 5 mA ($V_{IN}= 5\text{ V}, V_{OUT}= 30\text{ V}$)
- Low current consumption :
During operation: 100 μA (typ.) ($V_{IN}= 5\text{ V}$ 180 kHz)
During shutdown : 1.0 μA (max.)
- Shutdown function: Stepping up operation is stopped, and Vout pin is shorted to GND while shutdown.
- Input voltage range: 2.0 to 9.0 V
- Soft start function
- Built-in CR oscillation circuit:
Oscillating frequency: 180 kHz (typ.) (A series)
Oscillating frequency: 50 kHz (typ.) (B series)
- 8-pin SSOP plastic package
- 8-bit built-in electric volume circuit
- External transistor type is available (S-8331 Series)
- Lead-free products

■ Applications

- Power supplies for medium type or large type LCD panel.
- Power supplies for portable devices such as pagers, handy calculators, and remote controllers
- Constant voltage power supplies for cameras, video equipment, and communication equipment

■ Package

Package name	Drawing code		
	Package	Tape	Reel
8-Pin SSOP	FS008-A	FS008-A	FS008-A

STEP-UP, FOR LCD BIAS SUPPLY, 1-CHANNEL SWITCHING REGULATOR S-8330/8331 Series

Rev.5.1_00

■ Block Diagram

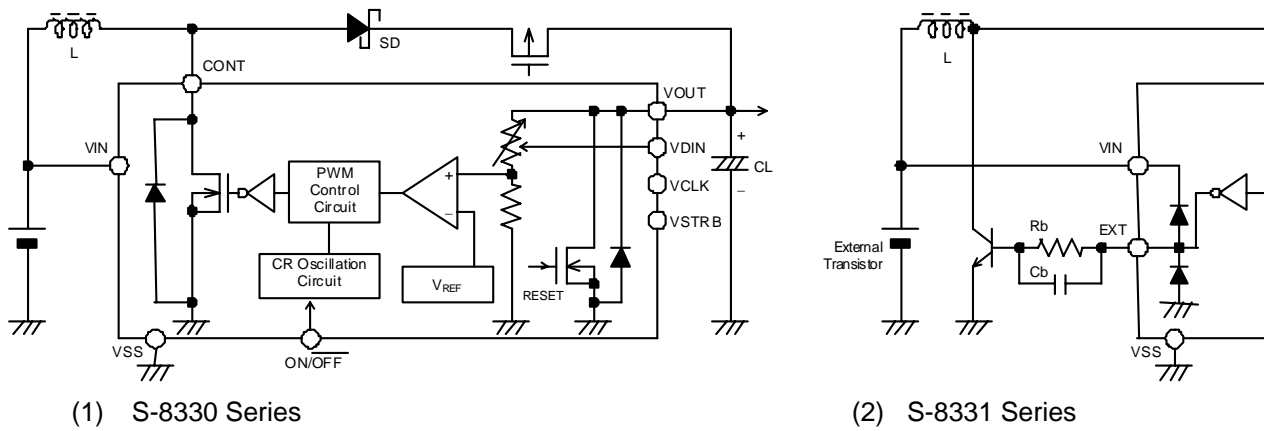
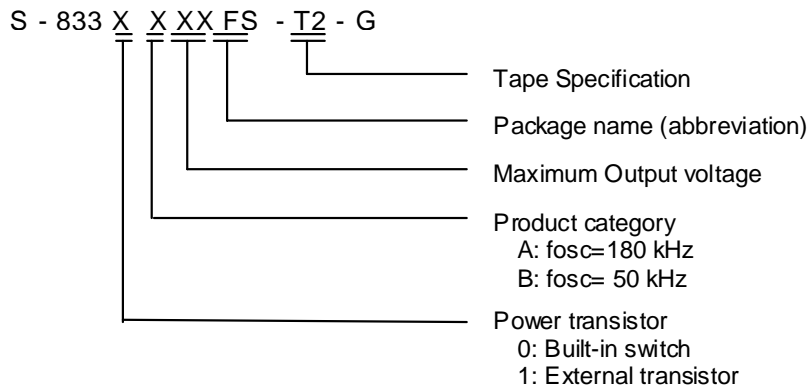

Figure 1 Block Diagram

■ Selection Guide

1. Product Name



2. Product list

Output voltage range (V)	S-8330AXXFS Series	S-8330BXXFS Series	S-8331AXXFS Series
8 to 20	S-8330A20FS-T2-G	S-8330B20FS-T2-G	S-8331A20FS-T2-G
10 to 22	S-8330A22FS-T2-G	S-8330B22FS-T2-G	S-8331A22FS-T2-G
12 to 24	S-8330A24FS-T2-G	S-8330B24FS-T2-G	S-8331A24FS-T2-G
14 to 26	S-8330A26FS-T2-G	S-8330B26FS-T2-G	S-8331A26FS-T2-G
16 to 28	S-8330A28FS-T2-G	S-8330B28FS-T2-G	S-8331A28FS-T2-G
18 to 30	S-8330A30FS-T2-G	S-8330B30FS-T2-G	S-8331A30FS-T2-G

STEP-UP, FOR LCD BIAS SUPPLY, 1-CHANNEL SWITCHING REGULATOR S-8330/8331 Series

Rev.5.1_00

■ Pin Assignment

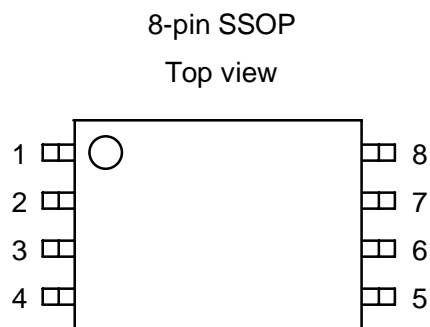

Figure 2 Pin Assignment

Pin No.	Symbol	Description
1	VDIN	Electric volume data input pin
2	VCLK	Electric volume clock input pin
3	VSTRB	Electric volume strobe signal input pin
4	V_{OUT}	Output voltage pin
5	V_{IN}	Power supply pin
6	CONT	External inductor connection pin (Note 1)
	EXT	External transistor connection pin (Note 2)
7	ON/ $\overline{\text{OFF}}$	Shutdown pin
		"H": normal operation (stepping up operation) "L": stop stepping up operation
8	V_{SS}	GND pin

Note 1: S-8330 Series: Open drain output

Note 2: S-8331 Series: CMOS output

STEP-UP, FOR LCD BIAS SUPPLY, 1-CHANNEL SWITCHING REGULATOR

S-8330/8331 Series

Rev.5.1_00

■ Absolute Maximum Ratings

(Unless otherwise specified: Ta=25°C)

Parameter	Symbol	Ratings	Unit
V _{OUT} pin voltage	V _{OUT}	V _{SS} – 0.3 to 33	V
CONT pin voltage	V _{CONT}	V _{SS} – 0.3 to 33	V
CONT pin current	I _{CONT}	300	mA
EXT pin voltage	V _{EXT}	V _{SS} – 0.3 to V _{OUT} +0.3	V
EXT pin current	I _{EXT}	±50	mA
Input voltage	V _{DIN} , V _{CLK} , V _{STRB} , V _{IN} , V _{ON/OFF}	V _{SS} – 0.3 to 10	V
Power dissipation	P _D	300 (When not mounted on board)	mW
		500 (Note 1)	mW
Operating temperature range	T _{opr}	–20 to +70	°C
Storage temperature	T _{stg}	–40 to +125	°C

Note 1: When mounted on board

[Mounted board]

- (1) Board size : 114.3 mm × 76.2 mm × t1.6 mm
- (2) Board name : JEDEC STANDARD51-7

Caution The absolute maximum ratings are rated values exceeding which the product could suffer physical damage. These values must therefore not be exceeded under any conditions.

(1) When mounted on board

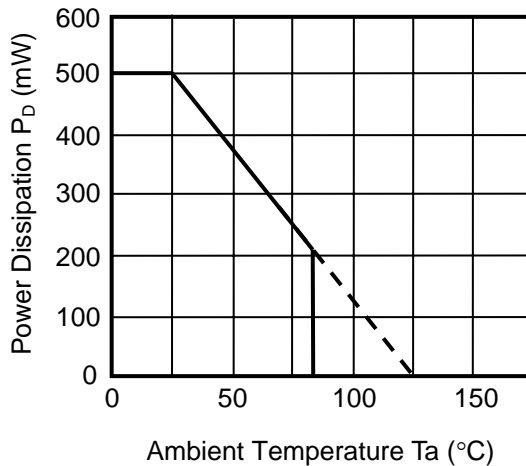

(2) When not mounted on board

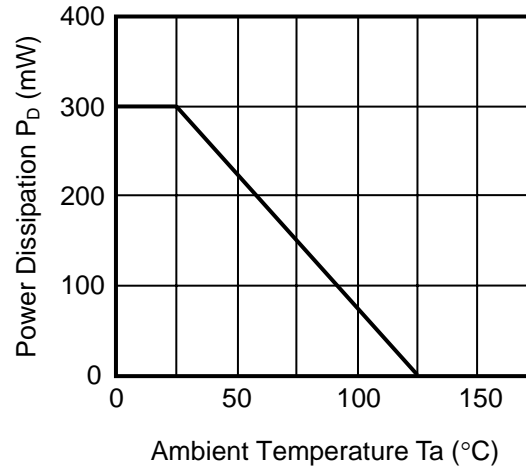

Figure 3 Power Dissipation of Package

STEP-UP, FOR LCD BIAS SUPPLY, 1-CHANNEL SWITCHING REGULATOR

S-8330/8331 Series

Rev.5.1_00

■ Electrical Characteristics

1. S-8330A Series

Step-Up Switching Regulator

(Unless otherwise specified: Ta=25°C)

Items	Symbols	Conditions	Min.	Typ.	Max.	Unit	Mea.Circ.	
Output voltage range	VOUT	S-8330A20FS	8	—	20	V	5	
		S-8330A22FS	10	—	22			
		S-8330A24FS	12	—	24			
		S-8330A26FS	14	—	26			
		S-8330A28FS	16	—	28			
		S-8330A30FS	18	—	30			
Output voltage accuracy					±2.4%	%	5	
Input voltage	VIN		2.0	—	9.0	V	2	
Current consumption 1	ISS1	VIN =5 V, VOUT = Output voltage Max.	—	100	200	μA	4	
Current consumption 2	ISS2	VIN =2 V, VOUT = Output voltage Min.	—	50	100	μA	4	
Current consumption during power off	ISSS	Power off pin =VDIN=0 V, VIN=VCLK=VSTRB=5 V	—	—	1.0	μA	4	
Switching current	ISW	VCONT=0.4 V	100	200	—	mA	—	
Switching transistor leakage current	ISWQ	Power off pin =0 V, VCONT=9 V	—	—	1.0	μA	3	
Line regulation	ΔVOUT1	VIN =3 V to 6 V	S-8330A20FS	—	±300	—	mV	5
			S-8330A22FS	—	±330	—		
			S-8330A24FS	—	±360	—		
			S-8330A26FS	—	±390	—		
			S-8330A28FS	—	±420	—		
			S-8330A30FS	—	±450	—		
Load regulation	ΔVOUT2	VIN =5 V IOUT=output voltage/2.4 MΩ to output voltage/24 kΩ	—	±30	—	mV	5	
Output voltage temperature coefficient	ΔVOUT/ΔTa	Ta= -20°C to +70°C	S-8330A20FS	—	±1.0	—	mV/°C	5
			S-8330A22FS	—	±1.1	—		
			S-8330A24FS	—	±1.2	—		
			S-8330A26FS	—	±1.3	—		
			S-8330A28FS	—	±1.4	—		
			S-8330A30FS	—	±1.5	—		
Oscillating frequency	fosc	VOUT =output voltage×0.95 Measure waveform at CONT pin	144	180	216	kHz	2	
Maximum duty ratio	Max Duty	VOUT =output voltage×0.95 Measure waveform at CONT pin	60	72	84	%	2	
Power off terminal input voltage	VSH1	VOUT =output voltage×0.95	VIN ≥ 3.0 V	2.4	—	V	2	
	VSH2	Check oscillation at CONT pin	VIN < 3.0 V	1.6	—			
	VSL	VOUT =output voltage×0.95 Check oscillation stop at CONT pin		—	—			0.4
Power off terminal input leakage current	ISL	VIN =9 V	-1	—	1	μA	1	
Soft start time	TSS		1	3	6	ms	—	
Efficiency	EFFI		—	85	—	%	5	

STEP-UP, FOR LCD BIAS SUPPLY, 1-CHANNEL SWITCHING REGULATOR
S-8330/8331 SeriesRev.5.1_00

Externally attached parts:

Coils : CD54 (47 μ H) of Sumida Corporation

Diodes: MA720 Schottky type of Matsushita Electric Industrial Co., Ltd.

Capacitors: F93 tantalum type (two circuits of 50 V, 4.7 μ F are connected in parallel) of Nichicon Corporation

$V_{IN}=5$ V, $V_{OUT}=V_{OUT}$ Max. I_{OUT} = output voltage /24 k Ω

ON/OFF=5 V, $V_{DIN}=V_{CLK}=V_{STRB}=0$ V

Note: Output voltage specified above is the typical value of the output voltage.

STEP-UP, FOR LCD BIAS SUPPLY, 1-CHANNEL SWITCHING REGULATOR

S-8330/8331 Series

Rev.5.1_00

2. S-8330B Series

Step-Up Switching Regulator

(Unless otherwise specified: Ta=25°C)

Item	Symbol	Conditions	Min.	Typ.	Max.	Unit	Mea. Cir.	
Output voltage range	VOUT	S-8330B20FS	8	—	20	V	5	
		S-8330B22FS	10	—	22			
		S-8330B24FS	12	—	24			
		S-8330B26FS	14	—	26			
		S-8330B28FS	16	—	28			
		S-8330B30FS	18	—	30			
Output voltage accuracy					±2.4%	%	5	
Input voltage	VIN		2.0	—	9.0	V	2	
Current consumption 1	ISS1	V _{IN} = 5 V, V _{OUT} = Output voltage Max.	—	40	80	μA	4	
Current consumption 2	ISS2	V _{IN} = 2 V, V _{OUT} = Output voltage Min.	—	20	40	μA	4	
Current consumption during power off	ISSS	Power off pin =VDIN=0 V, V _{IN} =VCLK=VSTRB=5 V	—	—	1.0	μA	4	
Switching current	ISW	VCONT=0.4 V	100	200	—	mA	—	
Switching transistor leakage current	ISWQ	Power off pin=0 V, VCONT=9 V	—	—	1.0	μA	3	
Line regulation	ΔVOUT1	V _{IN} = 3 V to 6 V	S-8330B20FS	—	±300	—	mV	5
			S-8330B22FS	—	±330	—		
			S-8330B24FS	—	±360	—		
			S-8330B26FS	—	±390	—		
			S-8330B28FS	—	±420	—		
			S-8330B30FS	—	±450	—		
Load regulation	ΔVOUT2	V _{IN} = 5 V I _{OUT} = Output voltage/2.4 MΩ to Output voltage/24 kΩ	—	±30	—	mV	5	
Output voltage Temperature coefficient	ΔVOUT/ΔTa	Ta = -20°C to +70°C	S-8330B20FS	—	±1.0	—	mV/°C	5
			S-8330B22FS	—	±1.1	—		
			S-8330B24FS	—	±1.2	—		
			S-8330B26FS	—	±1.3	—		
			S-8330B28FS	—	±1.4	—		
			S-8330B30FS	—	±1.5	—		
Oscillating frequency	fosc	V _{OUT} = Output voltage × 0.95 Measure waveform at CONT pin	40	50	60	kHz	2	
Maximum duty ratio	Max Duty	V _{OUT} = Output voltage × 0.95 Measure waveform at CONT pin	60	72	84	%	2	
Power off pin Input voltage	VSH1	V _{OUT} = Output voltage × 0.95	V _{IN} ≥ 3.0 V	2.4	—	—	V	2
	VSH2	Check oscillation at CONT pin	V _{IN} < 3.0 V	1.6	—	—		
	VSL	V _{OUT} = Output voltage × 0.95 Check oscillation stop at CONT pin		—	—	0.4		
Power off pin Input leakage current	ISL	V _{IN} = 9 V	-1	—	1	μA	1	
Soft start time	TSS		3	10	20	ms	—	
Efficiency	EFFI		—	85	—	%	5	

STEP-UP, FOR LCD BIAS SUPPLY, 1-CHANNEL SWITCHING REGULATOR
S-8330/8331 SeriesRev.5.1_00

Externally attached parts:

Coils : CD54 (47 μ H) of Sumida Corporation

Diodes : MA720 Schottky type of Matsushita Electric Industrial Co., Ltd.

Capacitors: F93 tantalum type (two circuits of 50 V, 4.7 μ F are connected in parallel) of Nichicon Corporation

$V_{IN}=5V, V_{OUT}=V_{OUT}$ Max. $I_{OUT}=\text{output voltage} / 24 \text{ k}\Omega$

ON/OFF=5 V, $V_{DIN}=V_{CLK}=V_{STRB}=0 \text{ V}$

Note: Output voltage specified above is the typical value of the output voltage.

STEP-UP, FOR LCD BIAS SUPPLY, 1-CHANNEL SWITCHING REGULATOR S-8330/8331 Series

Rev.5.1_00

3. S-8331A Series

Step-Up Switching Regulator

(Unless otherwise specified: Ta=25°C)

Item	Symbol	Conditions	Min.	Typ.	Max.	Unit	Mea. Cir.	
Output voltage range	V _{OUT}	S-8330A20FS	8	—	20	V	6	
		S-8330A22FS	10	—	22			
		S-8330A24FS	12	—	24			
		S-8330A26FS	14	—	26			
		S-8330A28FS	16	—	28			
		S-8330A30FS	18	—	30			
Output voltage accuracy					±2.4%	%	5	
Input voltage	V _{IN}		2.0	—	9.0	V	2	
Current consumption 1	ISS1	V _{IN} = 5 V, V _{OUT} = Output voltage Max.	—	50	100	μA	4	
Current consumption 2	ISS2	V _{IN} = 2 V, V _{OUT} = Output voltage Min.	—	25	50	μA	4	
Current consumption during power off	ISS3	Power off pin =VDIN=0 V, V _{IN} =VCLK=VSTRB=5 V	—	—	1.0	μA	4	
Output current at EXTpin	IEXTH	VEXT=V _{IN} -0.4 V	3.0	5.0	—	mA	—	
	IEXTL	VEXT=0.4 V	5.0	8.0	—	mA	—	
Line regulation	ΔV _{OUT1}	V _{IN} = 3 V to 6 V	S-8331A20FS	—	±300	—	mV	6
			S-8331A22FS	—	±330	—		
			S-8331A24FS	—	±360	—		
			S-8331A26FS	—	±390	—		
			S-8331A28FS	—	±420	—		
			S-8331A30FS	—	±450	—		
Load regulation	ΔV _{OUT2}	V _{IN} = 5 V I _{OUT} = Output voltage/2.4 MΩ to Output voltage/24 kΩ	—	±30	—	mV	6	
Output voltage Temperature coefficient	ΔV _{OUT} /ΔTa	Ta = -20°C to +70°C	S-8331A20FS	—	±1.0	—	mV/°C	6
			S-8331A22FS	—	±1.1	—		
			S-8331A24FS	—	±1.2	—		
			S-8331A26FS	—	±1.3	—		
			S-8331A28FS	—	±1.4	—		
			S-8331A30FS	—	±1.5	—		
Oscillating frequency	fosc	V _{OUT} = Output voltage × 0.95 Measure waveform at EXT pin	144	180	216	kHz	2	
Maximum duty ratio	Max Duty	V _{OUT} = Output voltage × 0.95 Measure waveform at EXT pin	60	72	84	%	2	
Power off pin Input voltage	VSH1	V _{OUT} = Output voltage × 0.95 V _{IN} ≥ 3.0 V	2.4	—	—	V	2	
	VSH2	Check oscillation at EXT pin V _{IN} < 3.0 V	1.6	—	—			
	VSL	V _{OUT} = Output voltage × 0.95 Check oscillation stop at EXT pin	—	—	0.4			
Power off pin Input leakage current	ISL	V _{IN} = 9 V	-1	—	1	μA	1	
Soft start time	TSS		1	3	6	ms	—	
Efficiency	EFFI		—	85	—	%	6	

STEP-UP, FOR LCD BIAS SUPPLY, 1-CHANNEL SWITCHING REGULATOR
S-8330/8331 SeriesRev.5.1_00

Externally attached parts:

Coils : CD54 (47 μ H) of Sumida Corporation

Diodes : MA720 Schottky type of Matsushita Electric Industrial Co., Ltd.

Capacitors: F93 tantalum type (two circuits of 50 V, 4.7 μ F are connected in parallel) of Nichicon Corporation.

Transistors: 2SD1624 of Sanyo Electric Co., Ltd.

Base resistance (Rb):1.0 k Ω

Base capacitor (Cb):2200 pF (ceramic type)

 $V_{IN}=5$ V, $V_{OUT}=V_{OUT}$ Max. $I_{OUT}=\text{output voltage}/24$ k Ω ON/OFF=5 V, $V_{DIN}=V_{CLK}=V_{STRB}=0$ V

Note: Output voltage specified above is the typical value of the output voltage.

STEP-UP, FOR LCD BIAS SUPPLY, 1-CHANNEL SWITCHING REGULATOR S-8330/8331 Series

Rev.5.1_00

4. Characteristics Common to S-8330/31 Series Electric Volume

(Unless otherwise specified: Ta=25°C)

Item	Symbol	Conditions	Min.	Typ.	Max.	Unit	Mea. cir.
Output voltage range (Note 1)	VOUT	S-833XX20FS	8	—	14	V	5 (6)
			14	—	20		
		S-833XX22FS	10	—	16		
			16	—	22		
		S-833XX24FS	12	—	18		
			18	—	24		
		S-833XX26FS	14	—	20		
			20	—	26		
		S-833XX28FS	16	—	22		
			22	—	28		
		S-833XX30FS	18	—	24		
			24	—	30		
Potential division accuracy			—	—	±2.4	%	5 (6)
Electric volume resolution			—	1/256	—		5 (6)
Error in linearity (Note 1)			—	—	±1/2	LSB	5 (6)
Data setup time	tsc		0.5	—	—	μA	—
Data hold time	thc		0.5	—	—	μA	—
VCLK falling edge to VSTRB rising edge	tss		0.5	—	—	μA	—
VSTRB pulse width	tda		0.5	—	—	μA	—
VSTRB falling edge to VCLK rising edge	ths		0.5	—	—	μA	—
VCLK pulse width	tdc		0.5	4.17	—	μA	—
VCLK period	ttc		5	8.33	—	μA	—
VDIN, VCLK, VSTRB Input voltage "H" level	VSHC1	V _{IN} ≥ 3.0 V	2.4	—	—	V	—
	VSHC2	V _{IN} < 3.0 V	1.6	—	—		
VDIN, VCLK, VSTRB Input voltage "L" level	VSLC		—	—	0.2		
VDIN, VCLK, VSTRB Input leakage current	ISLC	V _{IN} = 9 V	-1	—	1	μA	1

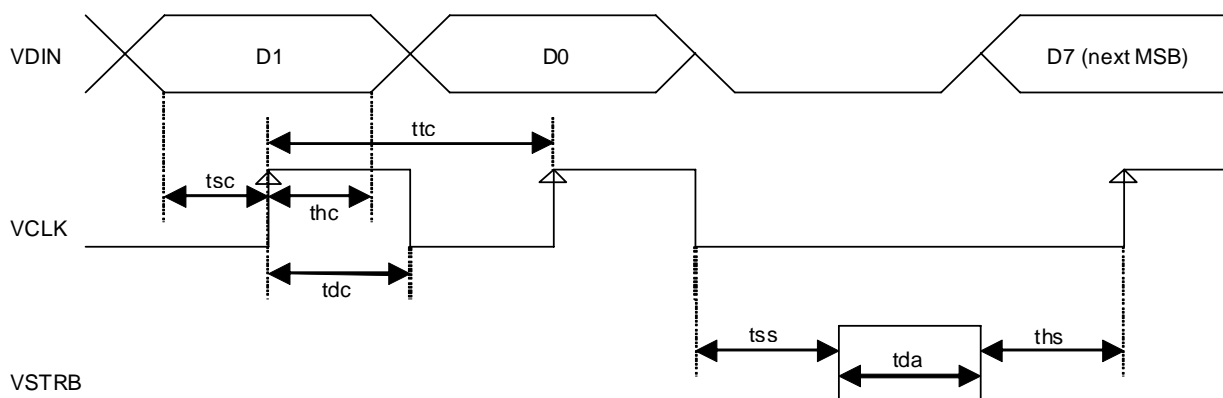

Figure 4 Data Input Timing

Note 1: An electric volume has 8-bit resolution. However, its error in linearity may exceed ±1/2LSB only before and after switching from 127 to 128 (from 01111111 to 10000000). When the electric volume is used within the variable range of 12 V, its error in linearity corresponds to 6 bits (±2.4% potential division accuracy is ensured).

STEP-UP, FOR LCD BIAS SUPPLY, 1-CHANNEL SWITCHING REGULATOR
S-8330/8331 Series

Rev.5.1_00

■ **Measurement Circuits**

1

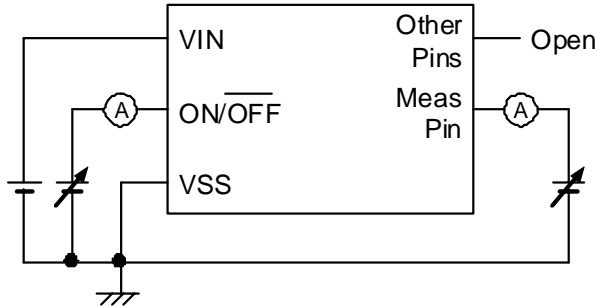

2

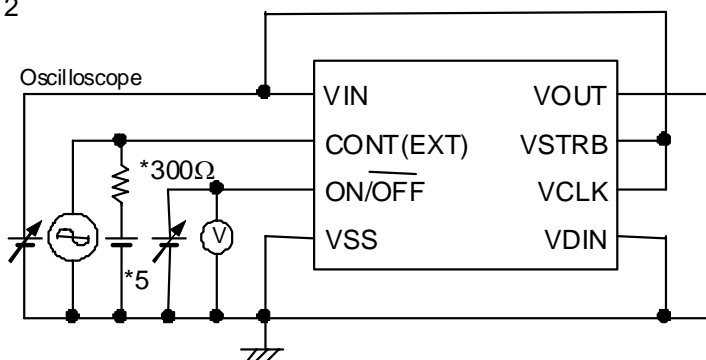

Not needed in the *S-8331 Series.

3

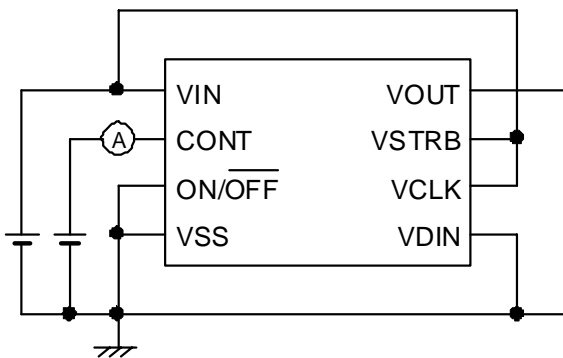

4

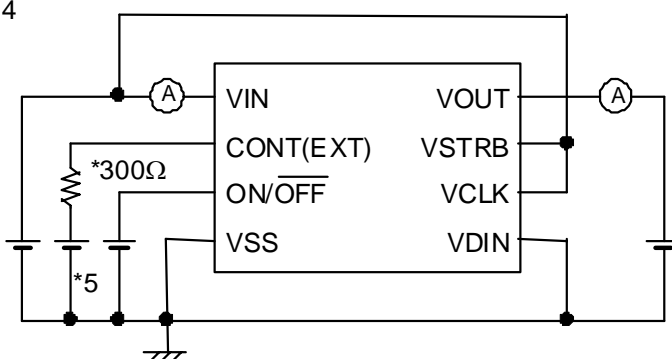

Not needed in the *S-8331 Series.

STEP-UP, FOR LCD BIAS SUPPLY, 1-CHANNEL SWITCHING REGULATOR S-8330/8331 Series

Rev.5.1_00

5

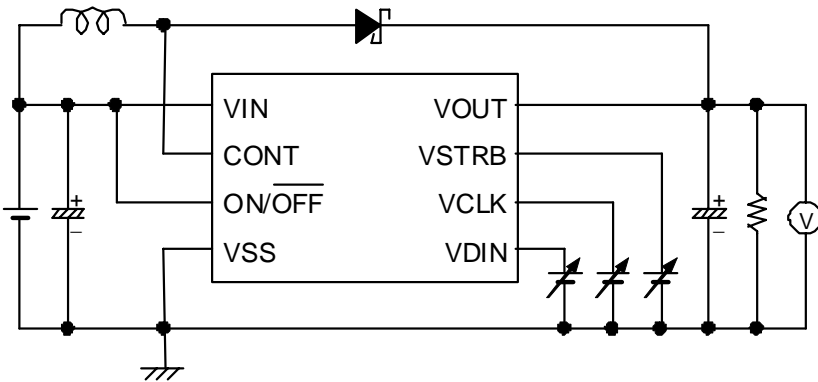

6

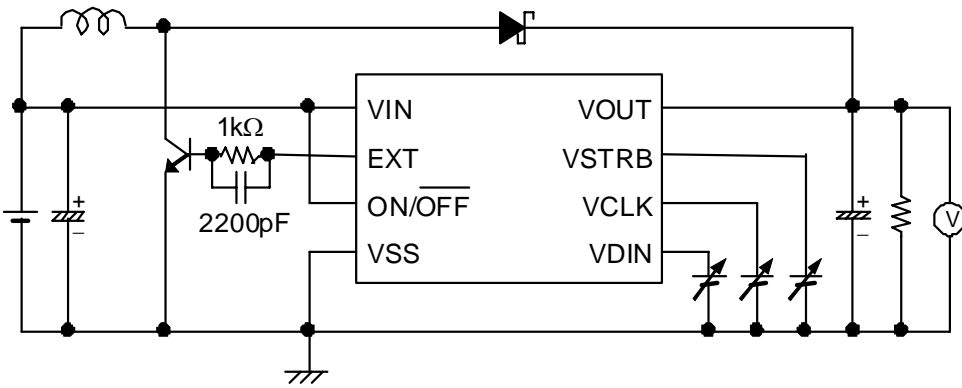

Figure 5 Measurement Circuits

STEP-UP, FOR LCD BIAS SUPPLY, 1-CHANNEL SWITCHING REGULATOR

S-8330/8331 Series

Rev.5.1_00

■ Operation

1. Step-Up DC-DC Converter

The S-8330/31 Series is a DC-DC converter using a pulse width modulation method (PWM) with low current consumption. Conventional PFM DC/DC converters have a drawback. Namely, an increase in the ripple voltage occurs because pulses are skipped when low output load current flows and the ripple frequency of the output voltage varies. In the S-8330/31 Series, the pulse width varies in the range of 0 % to 72 % depending upon the load current, but the switching frequency does not vary. This allows the ripple voltage due to switching to be reduced with a filter. Also, the internal soft start circuit controls the rush current and the output voltage overshoot to be generated when the IC starts the step-up operation by setting the power off pin to "H" level. At powering ON the IC, the rush current flows to charge up capacitive components of output capacitor "C_{OUT}" and load via coils and diodes.

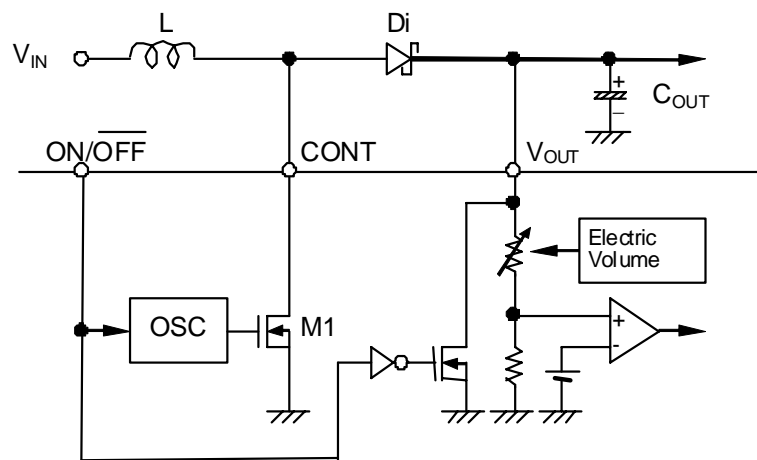

Figure 6 Step-Up DC-DC Converter

The following are fundamental equations of step-up switching regulators [(1) to (7)] (see Figure 6).

The pin voltage at CONT immediately after M1 is turned ON (current I_L which flows into L is zero):

$$V_A = V_S \text{ (1)}$$

(V_S : Not saturated voltage of M1)

Change in I_L with time:

$$\frac{dI_L}{dt} = \frac{V_L}{L} = \frac{V_{IN} - V_S}{L} \text{ (2)}$$

Integration of the above equation (I_L) is as follows:

$$I_L = \left(\frac{V_{IN} - V_S}{L} \right) \cdot t \text{ (3)}$$

I_L flows into L during t_{ON} . The time is determined depending upon the oscillating frequency of the OSC.

The peak current (I_{PK}) after t_{ON} :

$$I_{PK} = \left(\frac{V_{IN} - V_S}{L} \right) \cdot t_{ON} \text{ (4)}$$

The energy stored in L is represented by $1/2 \cdot L (I_{PK})^2$.

When M1 is turned OFF (t_{OFF}), the energy stored in L is transmitted through a diode. Then reverse voltage (V_L) generates.

STEP-UP, FOR LCD BIAS SUPPLY, 1-CHANNEL SWITCHING REGULATOR S-8330/8331 Series

Rev.5.1_00

 V_L :

$$V_L = (V_{OUT} + V_D) - V_{IN} \dots\dots\dots (5)$$

 $(V_D$; Diode forward voltage)The pin voltage at CONT rises only by the voltage corresponding to $V_{OUT}+V_D$.A change in the current (I_L) which flows through a diode into V_{OUT} during t_{OFF} :

$$\frac{dI_L}{dt} = \frac{V_L}{L} = \frac{V_{OUT} + V_D - V_{IN}}{L} \dots\dots\dots (6)$$

Integration of the above equation is as follows :

$$I_L = I_{PK} - \left(\frac{V_{OUT} + V_D - V_{IN}}{L} \right) \cdot t \dots\dots\dots (7)$$

During t_{ON} , the energy is stored in L and is not transmitted to V_{OUT} . When output current (I_{OUT}) flows from V_{OUT} , the energy of the capacitor (C_{OUT}) is consumed. As a result, the pin voltage at C_{OUT} decreases and goes to the lowest value after t_{ON} . When M1 is turned OFF, the energy stored in L is transmitted through a diode into C_{OUT} , and the pin voltage at C_{OUT} rises drastically. V_{OUT} is a time function that indicates the maximum value (ripple voltage V_{P-P}) when the current flowing into V_{OUT} through diode and load current I_{OUT} match. Next, the ripple voltage is found out based on the following equations:

 I_{OUT} when the time is set to t_1 until V_{OUT} reaches the maximum level immediately after t_{ON} :

$$I_{OUT} = I_{PK} - \left(\frac{V_{OUT} + V_D - V_{IN}}{L} \right) \cdot t_1 \dots\dots\dots (8)$$

$$\therefore t_1 = (I_{PK} - I_{OUT}) \cdot \left(\frac{L}{V_{OUT} + V_D - V_{IN}} \right) \dots\dots\dots (9)$$

 t_{OFF} when $I_L=0$ (the energy of the inductor is completely transmitted). Based on equation (7)

$$\left(\frac{L}{V_{OUT} + V_D - V_{IN}} \right) = \frac{t_{OFF}}{I_{PK}} \dots\dots\dots (10)$$

When substituting equation (10) for equation (9):

$$t_1 = t_{OFF} - \left(\frac{I_{OUT}}{I_{PK}} \right) \cdot t_{OFF} \dots\dots\dots (11)$$

Electric charge ΔQ_1 which is charged in C_{OUT} during t_1 :

$$\Delta Q_1 = \int_0^{t_1} I_L dt = I_{PK} \cdot \int_0^{t_1} dt - \frac{V_{OUT} + V_D - V_{IN}}{L} \cdot \int_0^{t_1} t dt = I_{PK} \cdot t_1 - \frac{V_{OUT} + V_D - V_{IN}}{L} \cdot \frac{1}{2} t_1^2 \dots\dots\dots (12)$$

When substituting equation (12) for equation (9):

$$\Delta Q_1 = I_{PK} - \frac{1}{2} (I_{PK} - I_{OUT}) \cdot t_1 = \frac{I_{PK} + I_{OUT}}{2} \cdot t_1 \dots\dots\dots (13)$$

A rise in voltage (V_{P-P}) due to ΔQ_1 :

$$V_{P-P} = \frac{\Delta Q_1}{C_{OUT}} = \frac{1}{C_{OUT}} \cdot \left(\frac{I_{PK} + I_{OUT}}{2} \right) \cdot t_1 \dots\dots\dots (14)$$

STEP-UP, FOR LCD BIAS SUPPLY, 1-CHANNEL SWITCHING REGULATOR S-8330/8331 Series

Rev.5.1_00

When taking into consideration ESR (Electric Series Resistance) RESR of IOUT and COUT during t1:

$$V_{P-P} = \frac{\Delta Q_1}{C_{OUT}} = \frac{1}{C_{OUT}} \cdot \left(\frac{I_{PK} + I_{OUT}}{2} \right) \cdot t_1 + \left(\frac{I_{PK} + I_{OUT}}{2} \right) \cdot R_{ESR} - \frac{I_{OUT} \cdot t_1}{C_{OUT}} \dots\dots\dots (15)$$

When substituting equation (15) for equation (11):

$$V_{P-P} = \frac{(I_{PK} - I_{OUT})^2}{2I_{PK}} \cdot \frac{t_{OFF}}{C_{OUT}} + \left(\frac{I_{PK} + I_{OUT}}{2} \right) \cdot R_{ESR} \dots\dots\dots (16)$$

The effective methods to reduce the ripple voltage are to maximize the capacitance of the capacitor connected to the output pin and to minimize ESR.

STEP-UP, FOR LCD BIAS SUPPLY, 1-CHANNEL SWITCHING REGULATOR S-8330/8331 Series

Rev.5.1_00

2. Power off pin (ON/ $\overline{\text{OFF}}$ pin)

This pin stops and starts set up operation.

Turning the power off pin to "L" stops the operation of the internal circuits excluding the electric volume, minimizes current consumption and short-circuits V_{OUT} pin to V_{SS} . At this time, current flows via coils and a diode at the input side into V_{SS} . Therefore, a switch to cut off the current is needed.

Figure 7 shows a circuit example using the NEC 2SJ356 (Pch MOS FET) as a current cutting switch. This circuit example turns ON and OFF the 2SJ356 in connection with the reset signal to the power off pin using a small signal transistor M_{N} (Nch MOS FET). A Zener diode (ZD) is used for the purpose of clamping voltage so as not to apply high voltage (20V or more) of the rated voltage between the gate and the source of the 2SJ356. However, when the circuit is used at 20 V or below, a Zener diode is not needed. Invalid current flowing into resistors R_{A} , R_{B} during step-up operation may affect the efficiency. Set R_{A} , R_{B} to the maximum level. If you set the resistance of R_{A} to the high value, a drop in the voltage occurs in resistor R_{A} due to off current of M_{N} and the current cutting switch 2SJ356 does not normally function. Be careful (Note that the efficiency characteristics shown in the reference data were measured without attaching a current cutting switch and is different from that shown in this example).

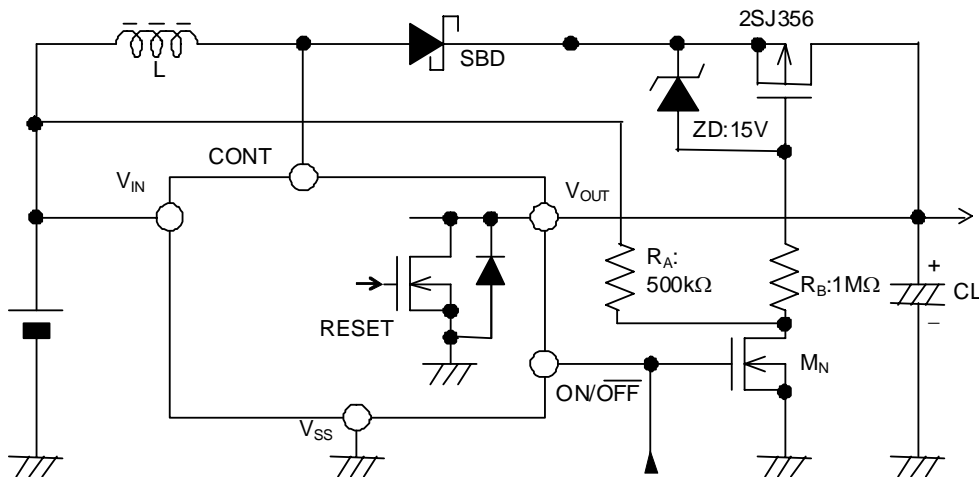

Figure 7 Circuit Example Using 2SJ356

The power off pin is configured as shown in Figure 8. DO NOT use this circuit under the floating state because the power off pin is not internally pulled up nor pulled down. If 0.4 V to 2.4 V when $V_{\text{IN}} \geq 3.0$ V, 0.4 V to 1.6 V when $V_{\text{IN}} < 3.0$ V are applied, current consumption increases. DO NOT apply voltage. When the power off pin is not used, connect it to V_{IN} pin.

The power off pin is not provided with hysteresis.

Power off pin	CR OSC	Output voltage
"H"	Operation	Setting value
"L"	Stop	V_{SS}

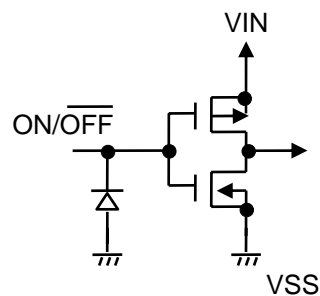

Figure 8

STEP-UP, FOR LCD BIAS SUPPLY, 1-CHANNEL SWITCHING REGULATOR

S-8330/8331 Series

Rev.5.1_00

3. Electric Volume

The S-8330/31 series incorporates an electric volume with an 8-bit shift register and an 8-bit latch. The output voltage is variable in the width of 12 V. The output voltage can be held in the data transmission mode because the data read in the shift register is fetched into the latch by unsynchronized strobe input. Figure 9 shows a block diagram and timing charts.

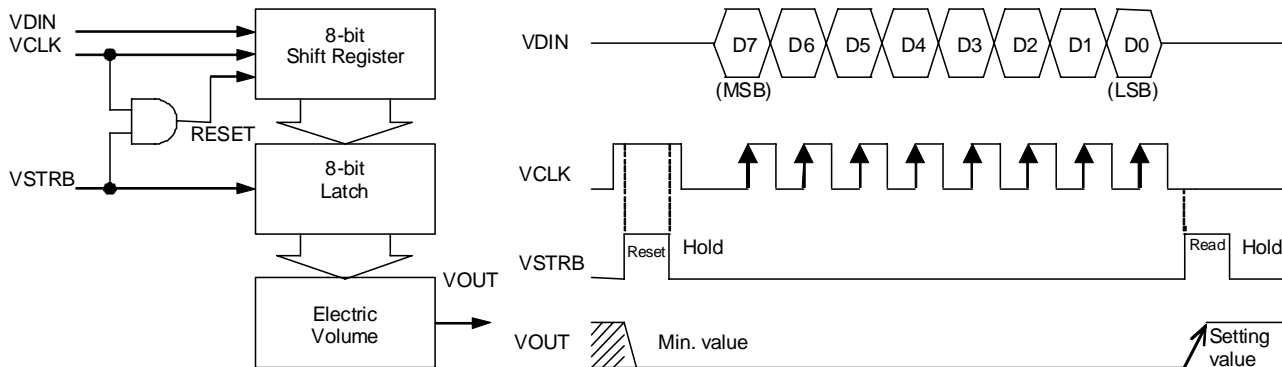

Figure 9 Block Diagram and Timing

VDIN: Inputs data to the electric volume.

"Data 1" is input at "H" level; "Data 0" is input at "Low" level.

VCLK: Inputs clock to the electric volume.

Fetches data at VDIN pin into the shift register at the rising edge of clocks. When clocks of over 8 bits are input, the read data is shifted in succession for each clock, and data corresponding to 8 bits which was input lastly is valid.

VSTRB: Inputs strobe signal.

The contents of the shift register are latched by turning the strobe signal to "H". When the data fetched into the latch is directly transmitted to the electric volume, the output voltage changes. Data in the latch is held by turning the strobe signal to "L".

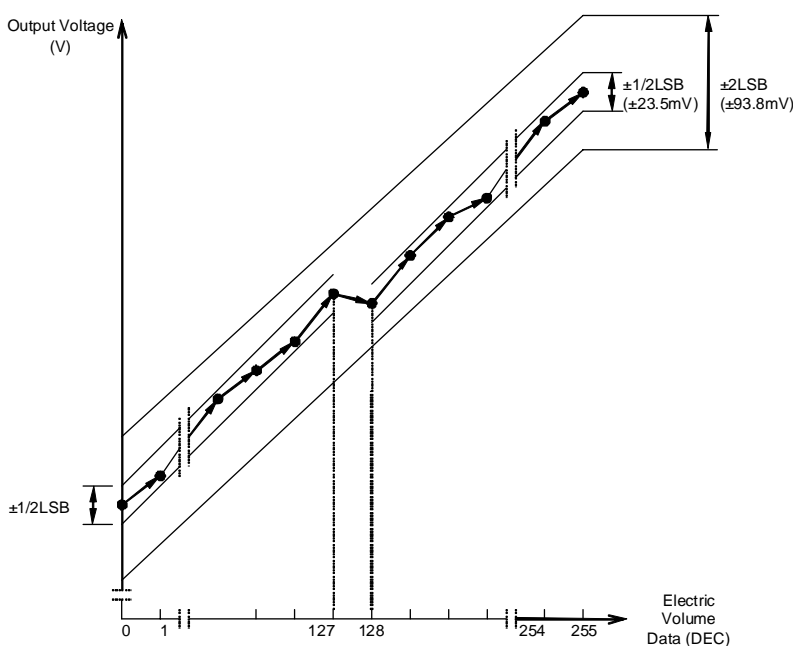

Figure 10 Linearity Accuracy

The electric volume has 8-bit resolution. An error in linearity may exceed $\pm 1/2\text{LSB}$ ($\pm 23.5\text{ mV}$) only before or after data changeover of $127 \leftrightarrow 128$ ($01111111 \leftrightarrow 10000000$) (see Figure 9).

The error in linearity corresponds to 6 bits ($\pm 93.8\text{ mV}$) when used in the 12 V variable range.

In an application where the variable range of output voltage is 6 V or less, it is possible to use it with high linearity accuracy with appropriate product selection. For example, if you want to change output voltage within the range from 12 V to 18 V, select the S-8330A24FS and use it within the range of $0 \leftrightarrow 127$ ($00000000 \leftrightarrow 01111111$). If so, high linearity accuracy (within $\pm 1/2\text{LSB}$) can be obtained.

The contents of the register must be reset because they are uncertain when powering on. If the power off pin is "L" level and step-up operation stops, the contents of the register are held inside the electric volume by applying voltage of 2 V or more between V_{IN} to V_{SS} . Data write and reset operation in the register are also available under this state. The register is reset by setting VCLK to "H" and VSTRB to "H". The output voltage is set to the minimum value. Power on under the state where the power off pin is being set to "L". Next, set VCLK to "H" and VSTRB to "H" to reset the contents of the register. Then, start step-up operation under the state where the power off pin is being set to "H".

[Note] If you start step-up operation without resetting the contents of the register after powering on, the maximum voltage is output to V_{OUT} , and the connected device or instrument may be broken or damaged. It is recommended to connect a pull down resistor to the power off pin if a problem may occur due to the maximum output voltage.

■ Recommended Selection of Series Products and External Parts

1. How to Select the Series Products

The S-8330/31 Series comes in three types depending upon the switching transistor attachment method (internal or external) and the oscillating frequency. As shown in Figure 11, respective output current targets differ to ensure high efficiency within the respective output current range. Select an appropriate series which meets your output current requirements (see the reference data for the output current and efficiency characteristics).

- ① S-8331A Series: The switching transistor is externally attached and the oscillating frequency is 180 kHz (typ.). Its target is the output current of 10 mA or more. High output voltage of 30 V or more is available by only attaching a simple external circuit to the S-8331A Series (see the S-8330 Series application circuit shown in Figure 17).
- ② S-8330A Series: The switching transistor is built in and the oscillating frequency is 180 kHz (typ.). Its target is the output current ranging from 1 mA to 10 mA. The oscillating frequency of the S-8330A Series is higher than that of the S-8330B Series. This minimizes ripple and ensures excellent transitory response characteristics.
- ③ S-8330B Series: The switching transistor is built in and the oscillating frequency is 50 kHz (typ.). Its target is output current of 1 mA or less. The self current consumption of the S-8330B Series is less than that of the S-8330A Series. This ensures high efficiency in the output current of about 0.1 mA or less.

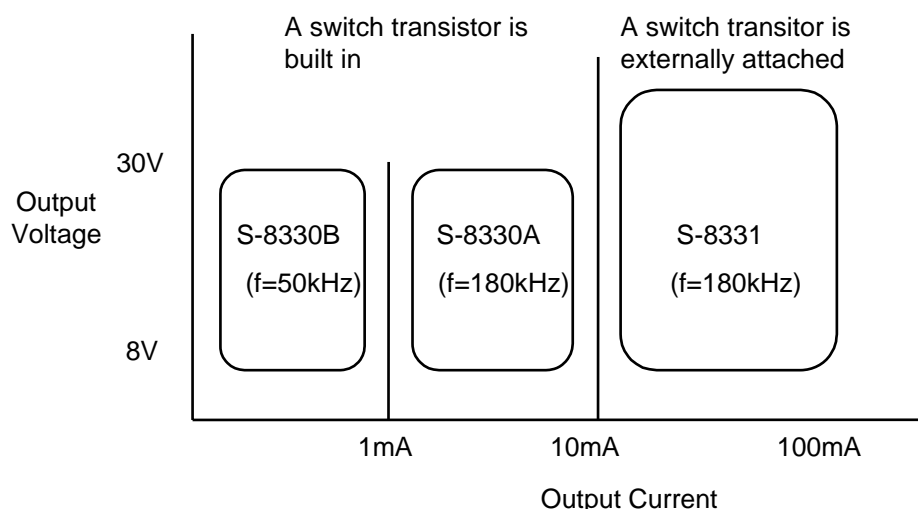

Figure 11 S-8330/8331 Series Depending Upon Output Current

STEP-UP, FOR LCD BIAS SUPPLY, 1-CHANNEL SWITCHING REGULATOR S-8330/8331 Series

Rev.5.1_00

2. Inductor

The inductance value greatly affects I_{OUT} and efficiency η .

Figure 12 shows the dependency of I_{OUT} , η of the S-8330A and the S-8330B on "L".

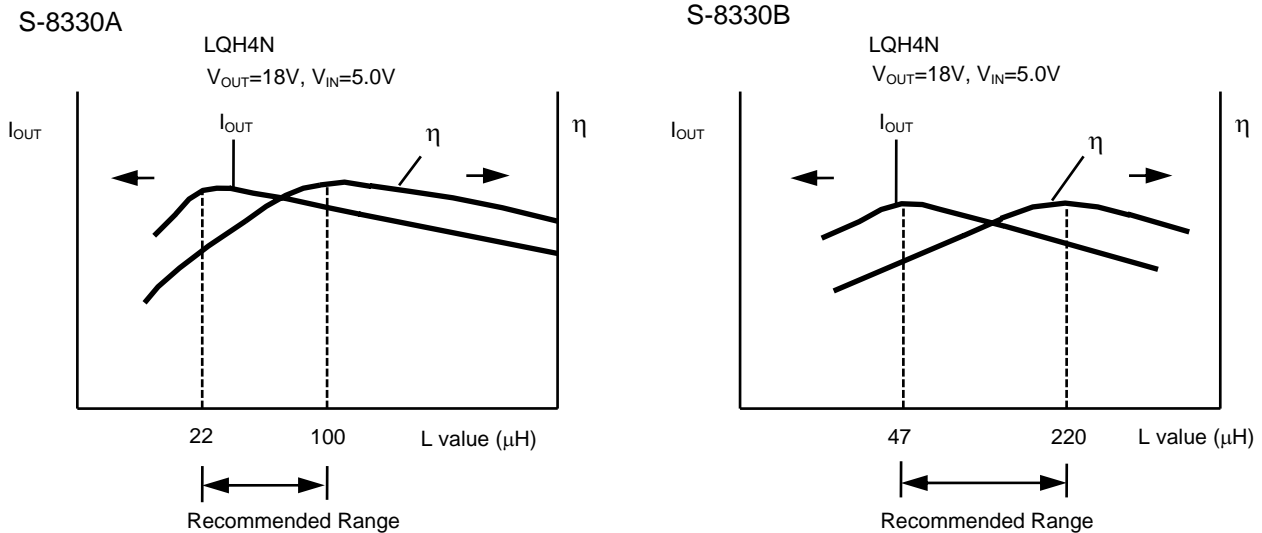

Figure 12 Dependency of Inductance On Maximum Output Current and Efficiency

The smaller value L , the larger peak current I_{PK} . I_{OUT} reaches the maximum value in a certain value L . When decreasing value L further, the switching transistor falls short of the current drive ability and I_{OUT} decreases; when increasing value L , a loss due to I_{PK} of the switching transistor decreases and the efficiency reaches the maximum in a certain value L ; when increasing value L , a loss due to a series resistor of the coils increases. This worsens the efficiency. So, it is recommended to set value L to 22 to 100 μH in the S-8330A and 47 to 220 μH in the S-8330B, respectively.

Determine value L referring to the reference data because the maximum output current actually differs depending upon the input voltage.

Pay attention to the allowable current of the inductor when selecting an appropriate inductor. If current exceeding this allowable current flows into the inductor, magnetic saturation occurs in the inductor. This may lead to a serious drop in the efficiency and damage of the IC due to excessive current.

Select an appropriate inductor so that I_{PK} does not exceed this allowable current. Current I_{PK} in the non-continuous mode is represented by the following equation.

$$I_{PK} = \sqrt{\frac{2 I_{OUT} (V_{OUT} + V_D - V_{IN})}{f_{OSC} \cdot L}} \quad (\text{A}) \dots \dots \dots (17)$$

Where f_{OSC} is the oscillating frequency. Set V_D to approximately 0.4 V. For example, when you want a power source of input voltage $V_{IN}=5\ \text{V}$, output voltage $V_{OUT}=30\ \text{V}$, and load current $I_{OUT}=5\ \text{mA}$, the S-8330A30FS responds to your requirements because $f_{OSC}=180\ \text{kHz}$. When you set value L to 47 μH , $I_{PK}=174\ \text{mA}$ is found out as shown in equation (17). As a result, you can select an inductor for which value L is 47 μH and the allowable current is 174 mA or more.

A limitation relating to the maximum value I_{PK} lies in the IC itself. Always use current I_{PK} at 500 mA or less.

STEP-UP, FOR LCD BIAS SUPPLY, 1-CHANNEL SWITCHING REGULATOR S-8330/8331 Series

Rev.5.1_00

3. Diode

Always use a diode which meets the following conditions.

- Low forward voltage: $V_F < 0.3 \text{ V}$
- Low switching speed: 500 ns max.
- Reverse direction voltage: $V_{OUT} + V_F$ or more
- Rating current: I_{PK} or more.

4. Capacitor (C_{IN} , C_{OUT})

Capacitor (C_{IN}) at the input side improves the efficiency by reducing the power impedance and stabilizing the input current. Select value (C_{IN}) depending upon the impedance of the power supply used.

The standard capacitance is approximately 10 μF . Select a capacitor (C_{OUT}) at the output side with small ESR (Equivalent Series Resistance) and large capacitance to stabilize the ripple voltage. The standard capacitance is approximately 10 μF . It is particularly recommended to use a tantalum electrolytic capacitor with excellent low temperature and leakage current characteristics.

5. Externally-attached transistors (S-8331 Series)

The output current can be increased by externally attaching a transistor to the S-8331 Series. A bipolar (NPN) type or an enhancement (Nch) MOS FET type of transistor can be used as an external transistor.

5.1 Bipolar NPN type

Figure 16 shows a circuit example using the 2SD1624 manufactured by Sanyo Electric Co., Ltd. as a bipolar transistor (NPN). The drive ability to increase output current is determined by values h_{FE} and R_b of the bipolar transistor. A peripheral circuit example of the transistor is shown in Figure 13.

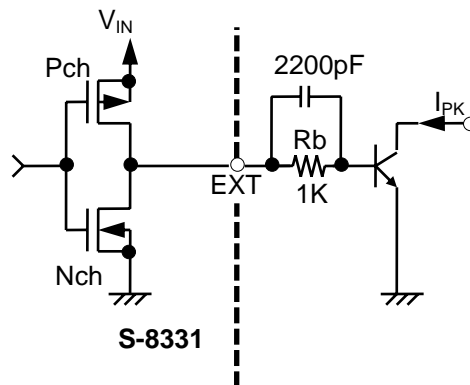

Figure 13 External Transistor Peripheral Circuit

It is recommended to select value R_b of approximately 1 $k\Omega$. Find necessary base current I_b from the bipolar transistor h_{FE} using $I_b = I_{PK} / h_{FE}$,

$$R_b = \frac{V_{IN} - 0.7}{I_b} - \frac{0.4}{|I_{EXT}|}$$

and select small value R_b . Small value R_b can increase the output current, but may worsen the efficiency. Also current may flow on the pulse or the voltage may drop due to wiring resistor. So, find the optimum value with experiments.

Attaching a speed-up capacitor C_b to the resistor R_b reduces switching loss and increases the efficiency.

$$\text{Value } C_b: C_b \leq \frac{1}{2\pi \times R_b \times f_{osc} \times 0.7}$$

STEP-UP, FOR LCD BIAS SUPPLY, 1-CHANNEL SWITCHING REGULATOR S-8330/8331 Series

Rev.5.1_00

5.2 Enhancement MOS FET type

Figure 14 shows a circuit example using the 2SK2159 manufactured by NEC Electronics Corporation as a MOS FET transistor (Nch). Use an Nch power MOS FET as a MOS FET. The EXT pin in the S-8331 series can drive a MOS FET with approx.1000 pF gate capacitance. The ON resistor of the MOS FET depends upon a difference between voltage input voltage V_{IN} and the threshold voltage of the MOS FET and thereby affects the output amperage and the efficiency. The gate voltage and the current of the MOS FET are supplied by input voltage V_{IN} . So pay attention if the input voltage is low. Also note that the IC will not function if the threshold voltage of the MOS FET is higher than the input voltage.

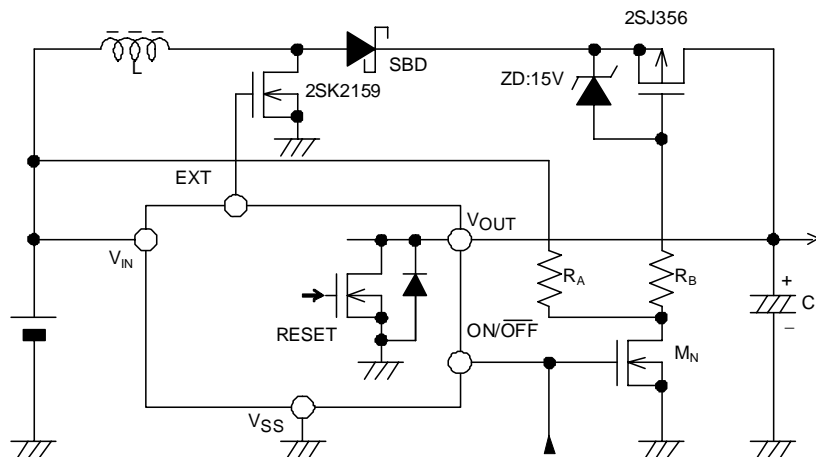

Figure 14 Circuit Example Using the 2SK2159

STEP-UP, FOR LCD BIAS SUPPLY, 1-CHANNEL SWITCHING REGULATOR
S-8330/8331 Series

Rev.5.1_00

■ **Standard Circuits**

(1) S-8330 Series

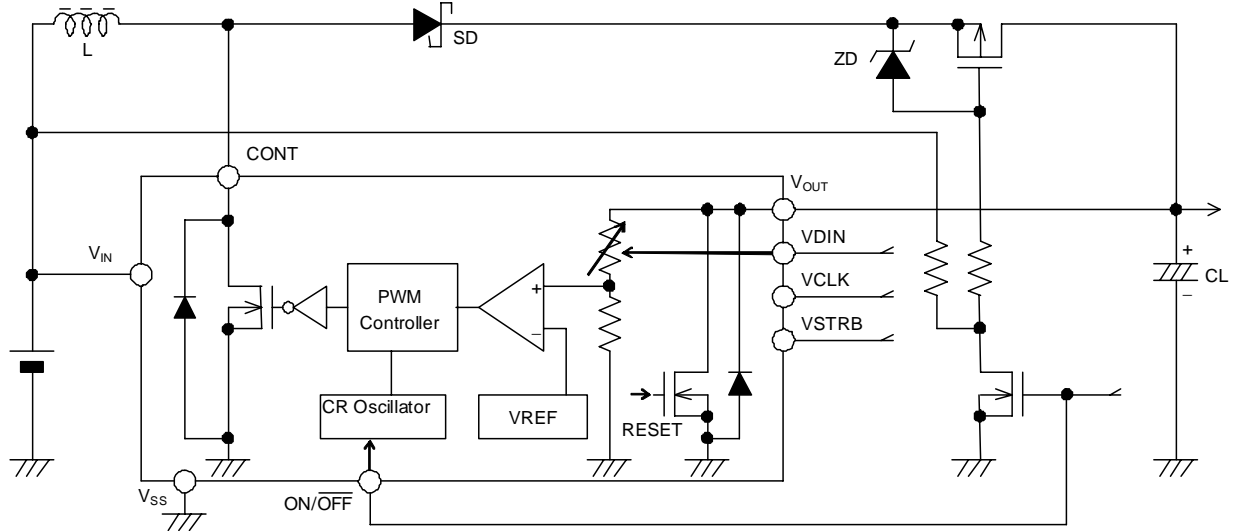

Figure 15 S-8330 Series

(2) S-8331 Series

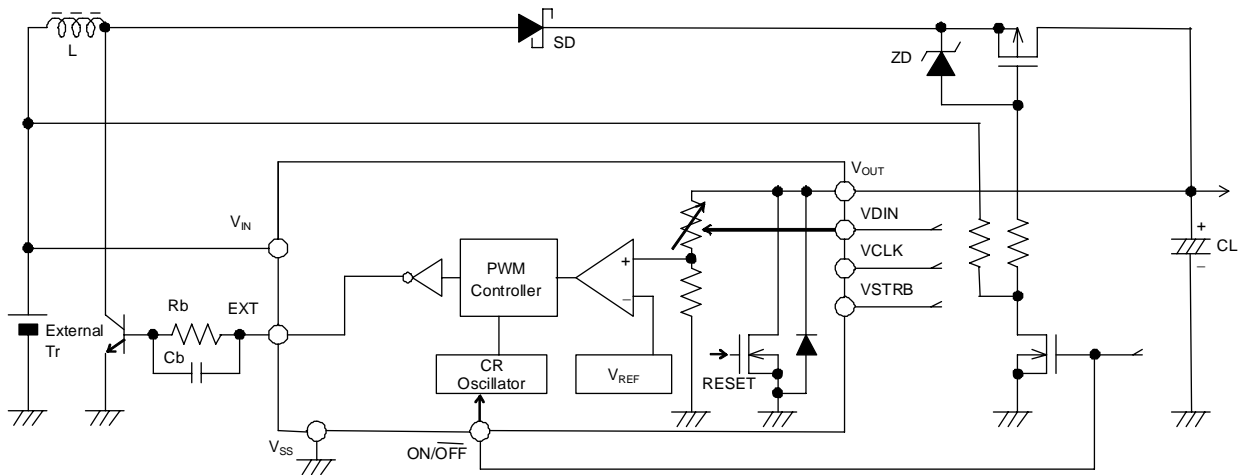

Figure 16 S-8331 Series

STEP-UP, FOR LCD BIAS SUPPLY, 1-CHANNEL SWITCHING REGULATOR S-8330/8331 Series

Rev.5.1_00

■ Precautions

- Mount capacitors, diodes, coils and other components as near as possible to the IC.
- Inherent ripple voltage or spike noise may generate in the switching regulator. Because it greatly depends upon the coils and the capacitors you use, check it using an actually-mounted model.
- Make sure that a loss in the switching transistor (particularly at high temperatures) does not exceed the allowable power dissipation.
- Configure parts and components so that the line to the VSS pin (indicated by the bold line shown in Figure 17) becomes short as much as possible. If a resistor and/or an inductance component stays on the line, the VSS potential of the IC varies depending upon the switching current.

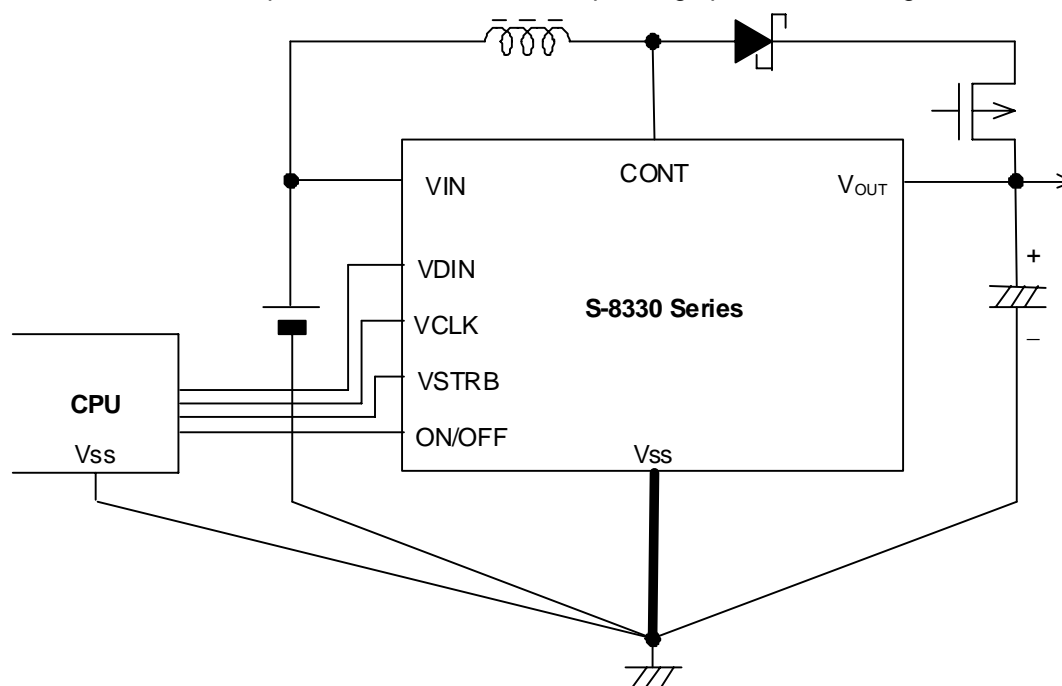

Figure 17 S-8330 Series Application Circuit

- When switching the output voltage by the electric volume, the soft start does not function. Pay attention to overshoot occurring when increasing the output voltage with a large width (refer to 5. Output Voltage Changeover shown in the transitory response characteristics).
- **Seiko Instruments Inc. shall not be responsible for any patent infringement by products including the S-8330/8331 Series in connection with the method of using the S-8330/8331 Series in such products, the product specifications or the country of destination thereof.**

STEP-UP, FOR LCD BIAS SUPPLY, 1-CHANNEL SWITCHING REGULATOR S-8330/8331 Series

Rev.5.1_00

■ Application Circuits

1. Large Size LCD Panel Drive Power Supply

This is a circuit example to drive a large size LCD panel (40 V/20 mA) at a 5-V power (5 V±10%).

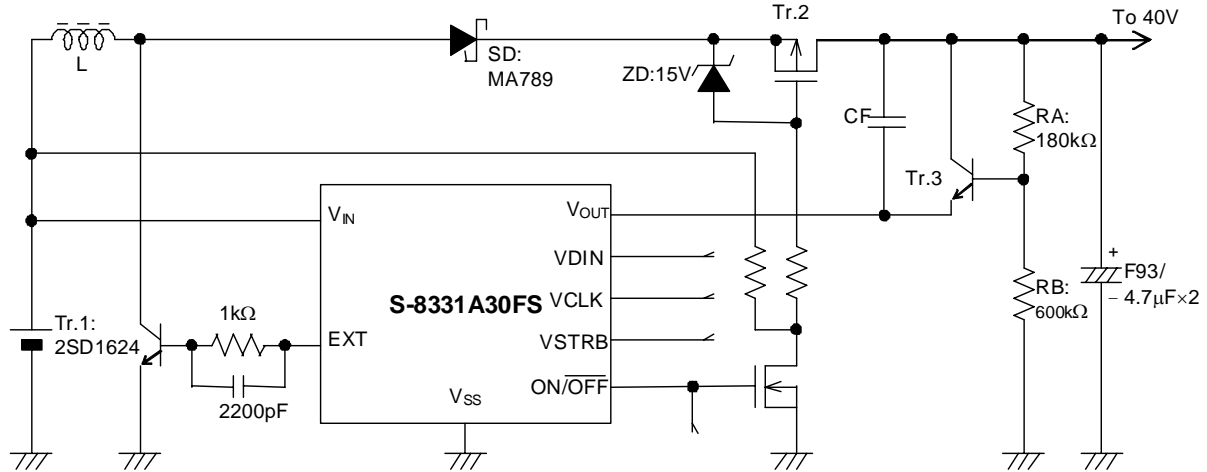

Figure 18 Large Size LCD Panel Drive Power Supply

This is an output voltage step-up circuit using the S-8331 Series. 30 V or more output voltage, i.e., the maximum voltage of the S-8330/8331 Series, is available by dividing the output voltage by external resistors RA and RB and feeding back to V_{OUT} pin. In the S-8331 Series the internal impedance of V_{OUT} pin varies by switching the electric volume. Therefore, a small signal NPN transistor (Tr. 3) is needed between the external voltage dividing resistor and V_{OUT} pin to convert the impedance. The output voltage is represented by equation (18).

$$\text{Output voltage} = \left(\frac{RB}{RA + RB} \right) \cdot (V_{OUT} + V_{BE}) \dots\dots\dots(18)$$

V_{OUT} : S-8331 V_{OUT} setting voltage

V_{BE} : Voltage between the base and the emitter of Tr. 3

Pay attention to the following precautions when using this IC.

- Make sure that the switching transistor (Tr.1) and a Schottky diode (SD) have sufficient resistance against high output voltage you use. For example, the 2SD1624 manufactured by Sanyo Electric Co., Ltd. and the MA789 manufactured by Matsushita Electric Industrial Co., Ltd. are used in this circuit example for a switching transistor and a Schottky diode, respectively.
- When stopping step-up operation from the step-up operation state using the power off pin, V_{OUT} pin is short-circuited to V_{SS} by an Nch transistor. Because of this, the output voltage is temporarily added to the area between the collector and the emitter of the transistor (Tr. 3). Always use a small signal transistor which is sufficient enough to withstand high output voltage (Tr. 3).
- The output voltage fails to stabilize when the output current falls short to 1 mA or less. In this case, add a capacitor CF between the output line and the V_{OUT} pin. The recommended capacitance of the capacitor is approx. 0.01 μF. Select the best capacitance after checking it under actual operation conditions.

STEP-UP, FOR LCD BIAS SUPPLY, 1-CHANNEL SWITCHING REGULATOR S-8330/8331 Series

Rev.5.1_00

2. Medium Size LCD Panel Drive Power Supply for PDA

Voltage suitable for smart addressing (SA) and multiple line addressing (A) drive generates from a 3 V- or 5 V-power supply. The following is a circuit example and its characteristics, targeted at positive voltage of approx. +15 V/500 μ A and negative voltage of approx. -9 V/500 μ A.

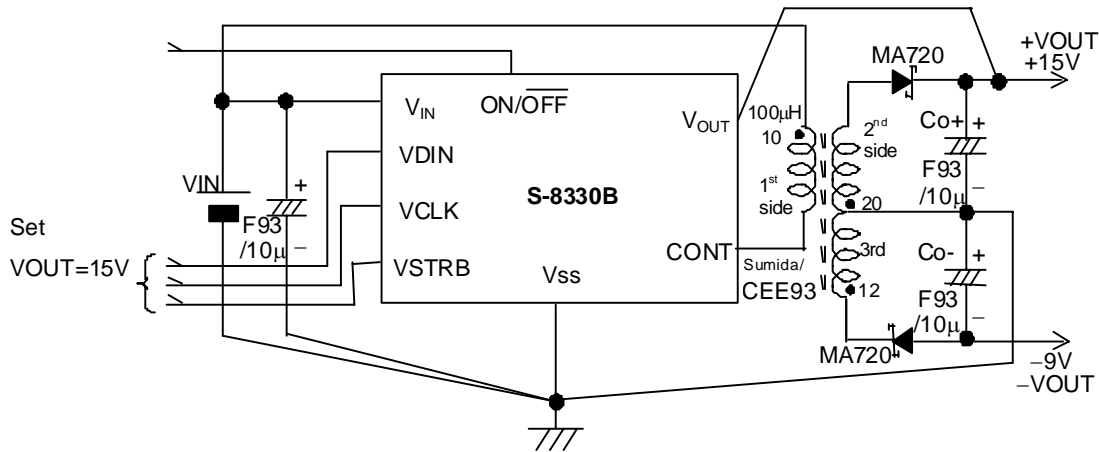
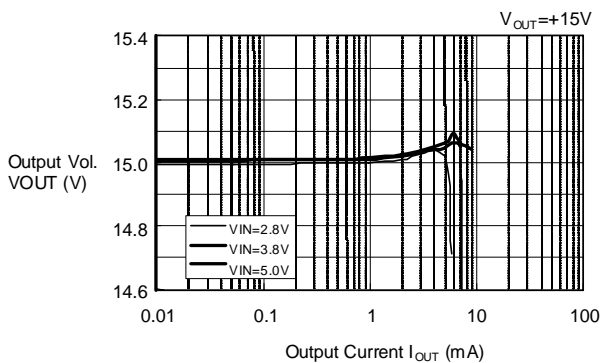
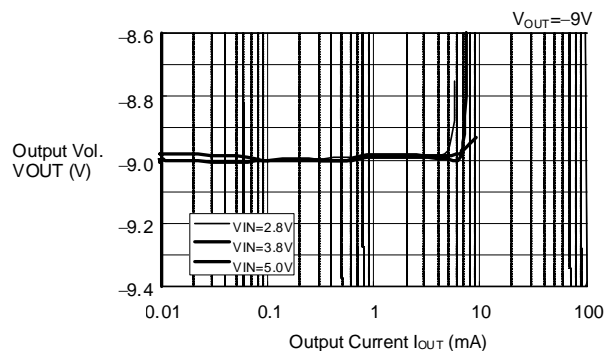

Figure 19 Medium Size LCD Panel Drive Power Supply for PDA

Output Current - Output voltage characteristics (Output Current Increase)



Output Current - Output Voltage Characteristics (Output Current Increase)



Output Current - Efficiency Characteristics (Output Current Increase)

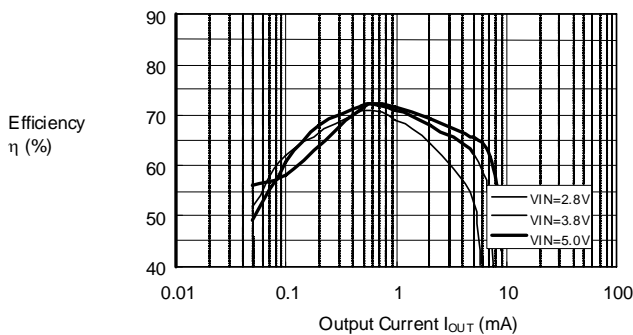

This circuit stabilizes the positive output voltage +VOUT in the S-8330B Series. The negative output voltage -VOUT is determined and stabilized by the wiring ratio at the second and third sides in the transducer manufactured by Sumida Corporation (CEE93 6375-002 non-gap type) when the output current at the positive side is the same as that at the negative side. Also this circuit is targeted at applications at low load. The use of a 50 kHz product with low switching frequency improves the efficiency at load of approx. 500 mA.

STEP-UP, FOR LCD BIAS SUPPLY, 1-CHANNEL SWITCHING REGULATOR
S-8330/8331 SeriesRev.5.1_00

Pay attention to the following precautions when using it.

- Generally, the allowable current level of the thin transducer (CEE93 equivalent) is lower than that of the thin coil (CD54 equivalent). Make sure that the current flowing into the transducer under the specified operational conditions does not exceed the allowable current. For example, if load current is larger than 5 mA in the above circuit, magnetic saturation occurs and the IC may be damaged at the worst.
- When using an external gap-type transducer, the stability in the negative output voltage may worsen.

STEP-UP, FOR LCD BIAS SUPPLY, 1-CHANNEL SWITCHING REGULATOR

S-8330/8331 Series

Rev.5.1_00

Temperature Characteristics

I_{SS1}, I_{SS2} — Temp

S-8330A

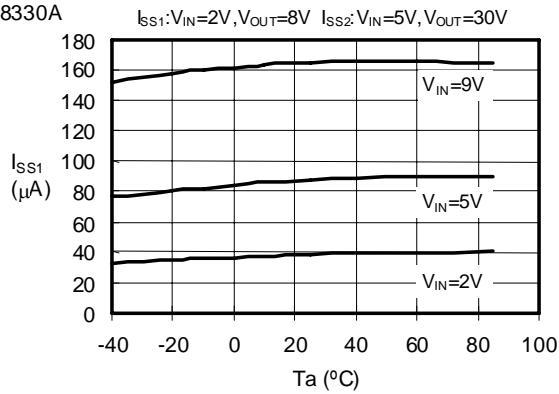

I_{SS1}, I_{SS2} — Temp

S-8331A

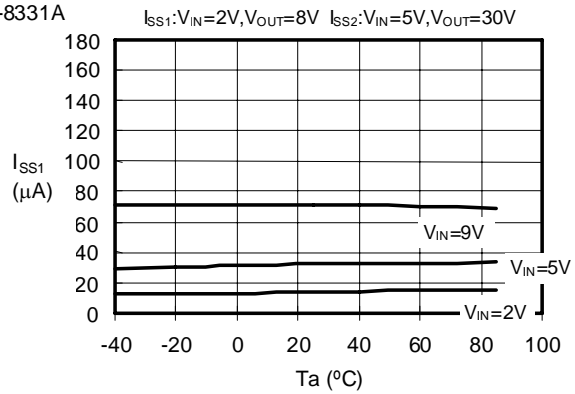

I_{SSS} — Temp

S-8330A

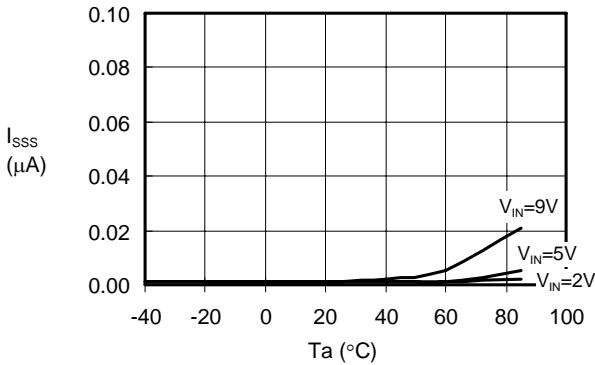

I_{SSS} — Temp

S-8331A

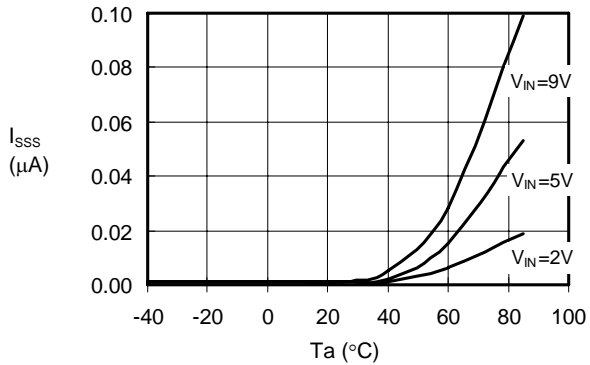

I_{SWQ} — Temp

S-8330A/B

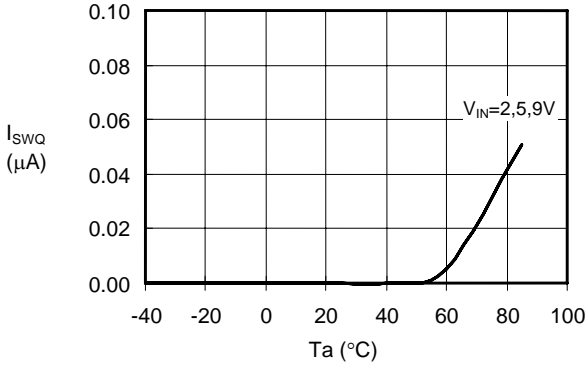

MaxDuty — Temp

S-8330A/31A

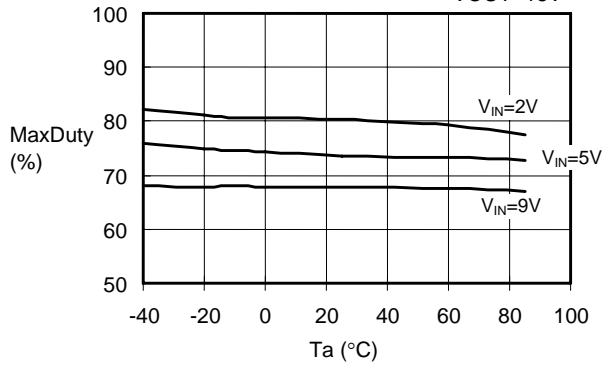

Power Supply Dependency Characteristics

$F_{OSC} - V_{IN}$

S-8330A/31A

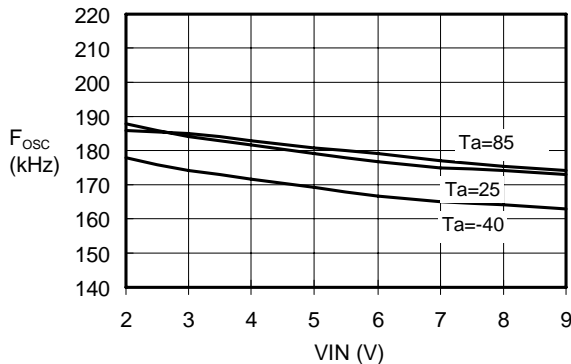

$I_{SW} - V_{IN}$

S-8330A/B

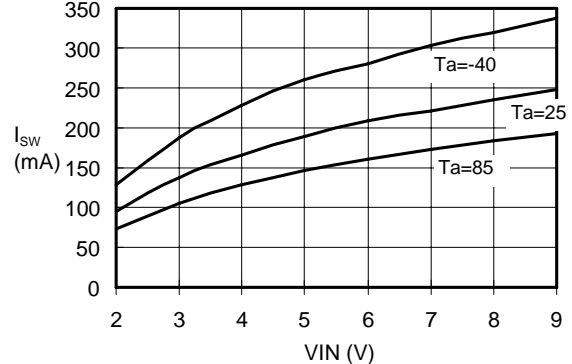

STEP-UP, FOR LCD BIAS SUPPLY, 1-CHANNEL SWITCHING REGULATOR
S-8330/8331 Series

Rev.5.1_00

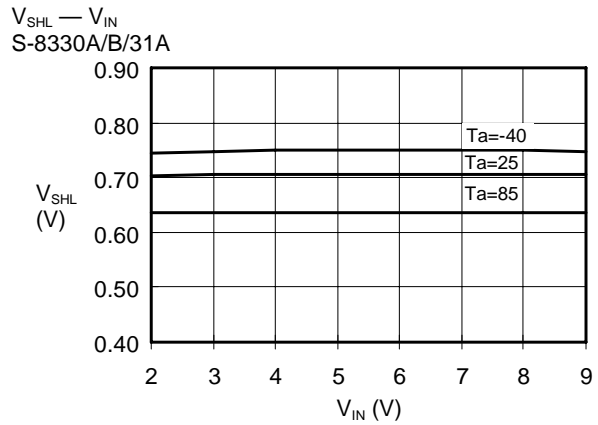
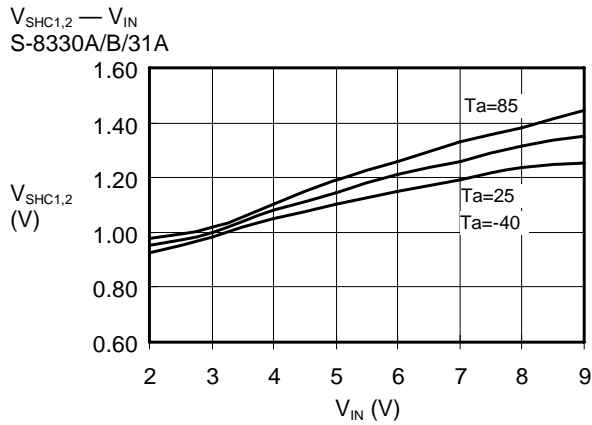
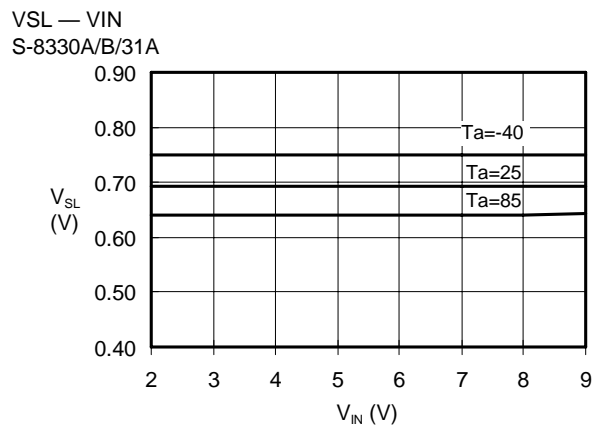
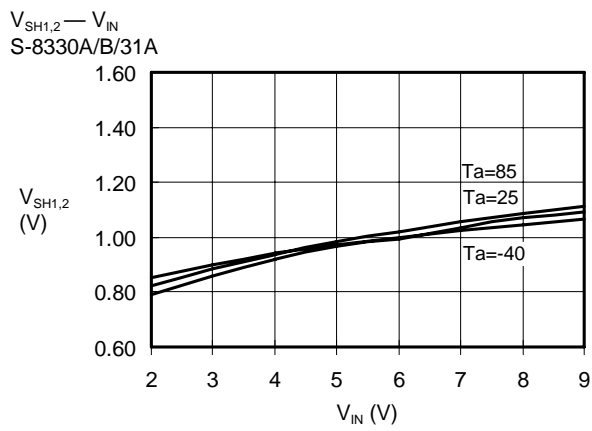
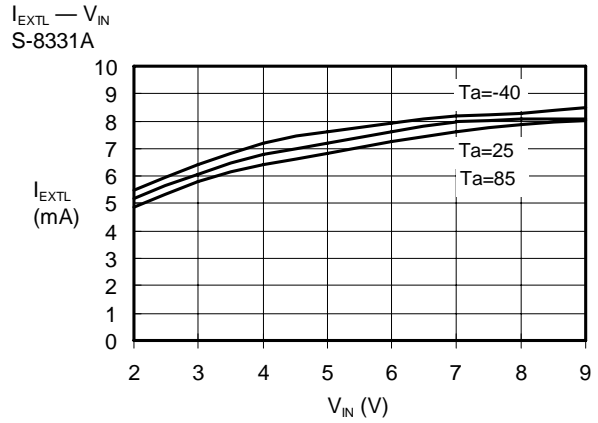
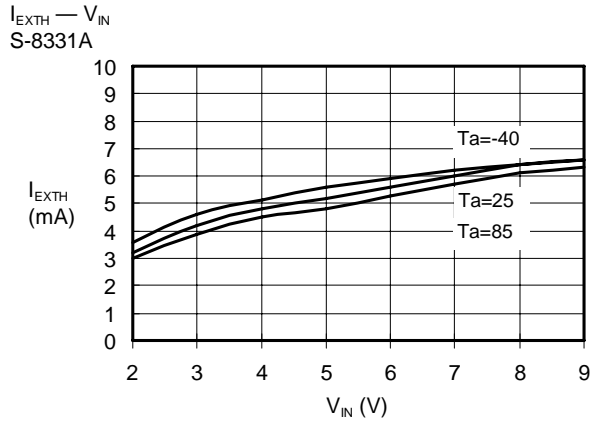

STEP-UP, FOR LCD BIAS SUPPLY, 1-CHANNEL SWITCHING REGULATOR

S-8330/8331 Series

Rev.5.1_00

■ Transitory Response Characteristics

1. Powering On (V_{IN} : 0V→5.0 V)

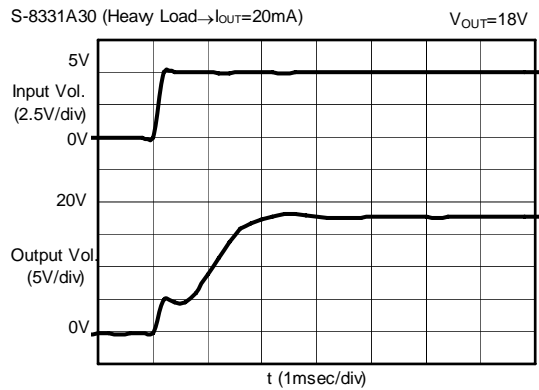
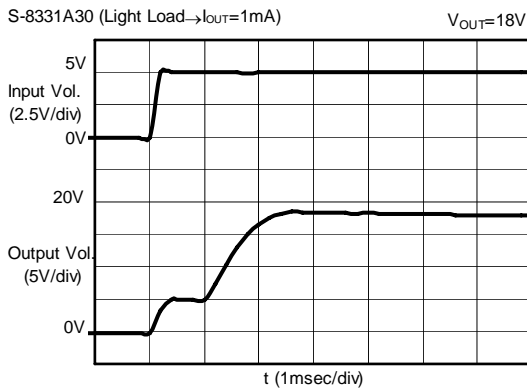
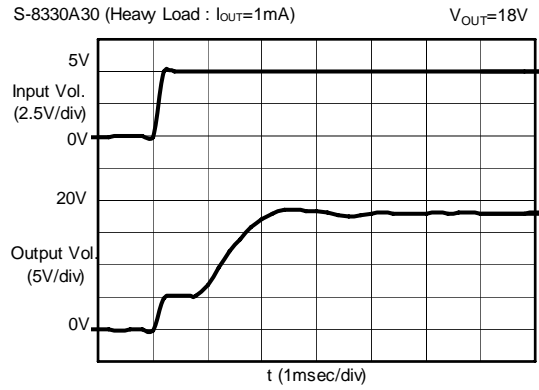
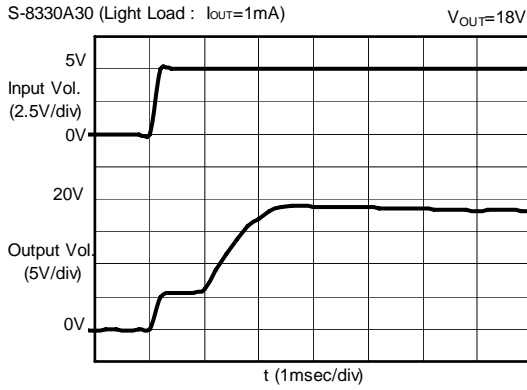

2. Power Off Pin Response ($V_{on/off}=0\rightarrow 5.0 V$)

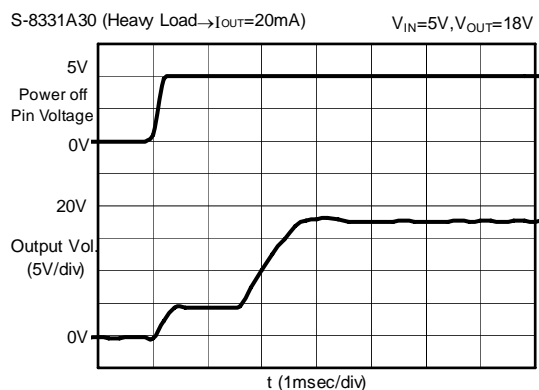
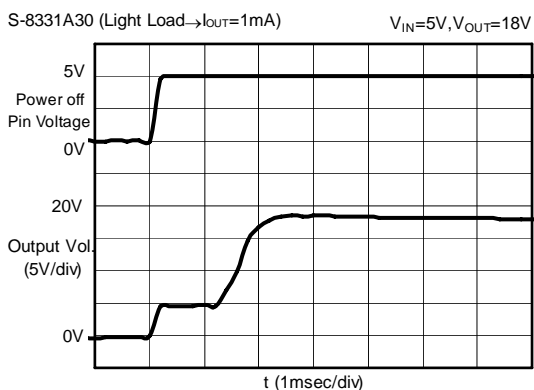
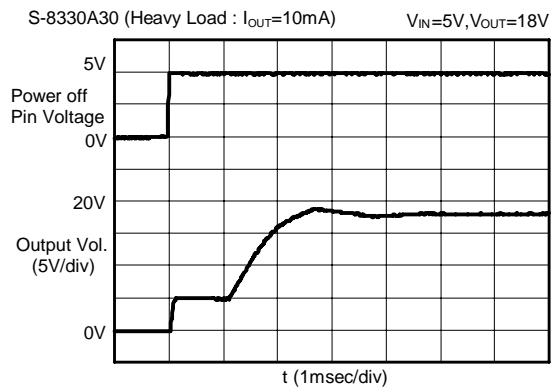
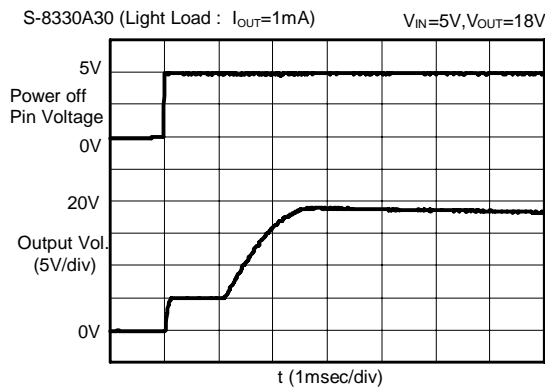

STEP-UP, FOR LCD BIAS SUPPLY, 1-CHANNEL SWITCHING REGULATOR S-8330/8331 Series

Rev.5.1_00

3. Load Variations

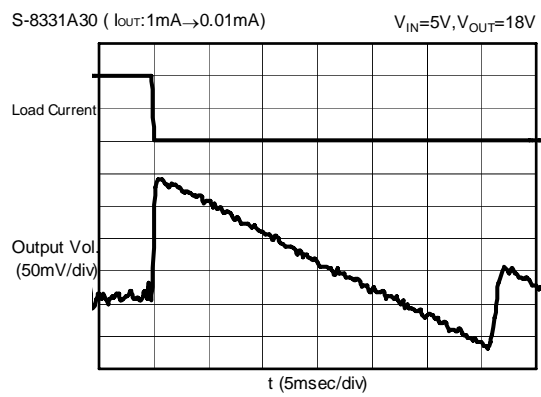
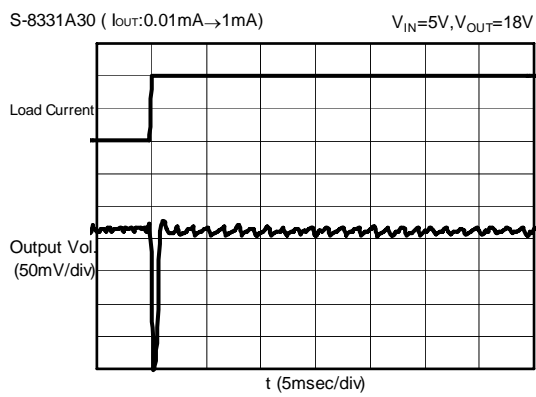
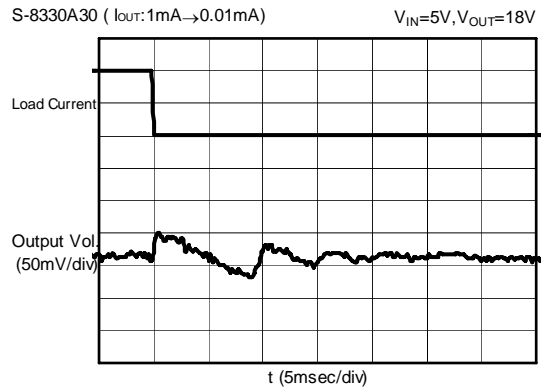
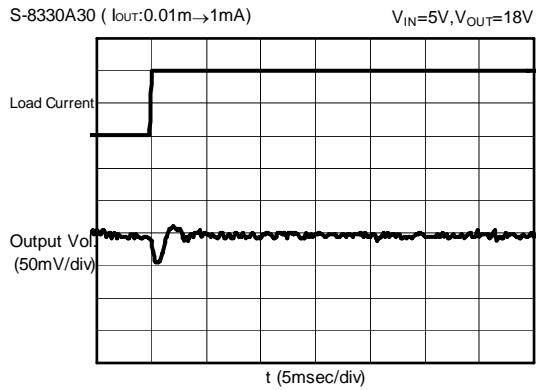

4. Power Supply Variations

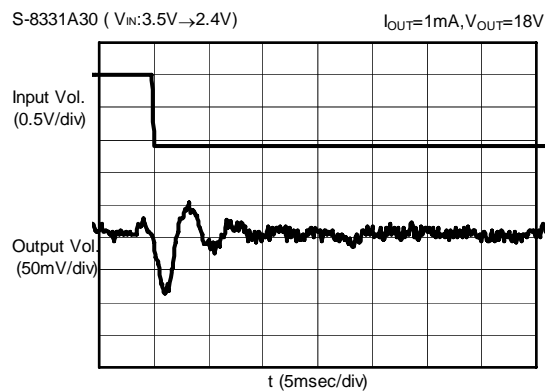
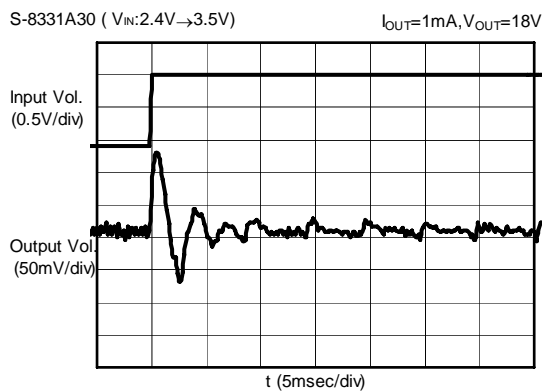
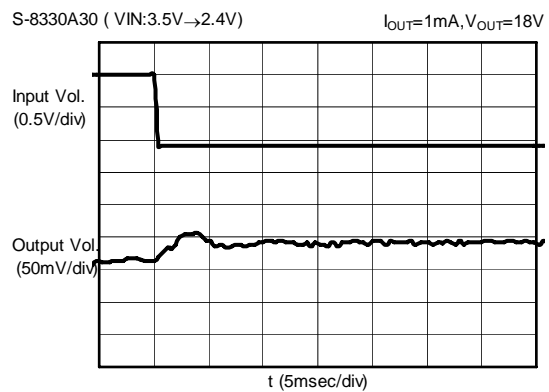
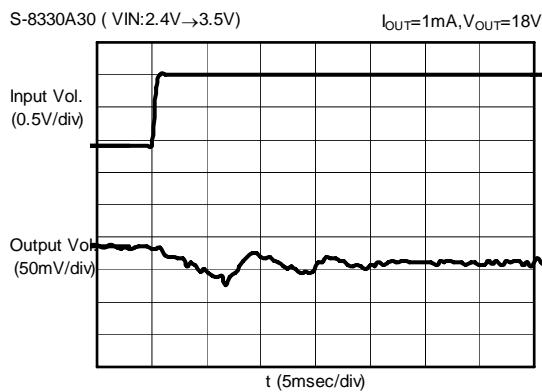

STEP-UP, FOR LCD BIAS SUPPLY, 1-CHANNEL SWITCHING REGULATOR
S-8330/8331 Series

Rev.5.1_00

5. Output Voltage Changeover

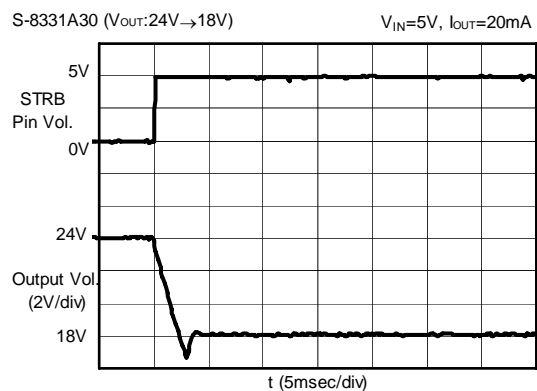
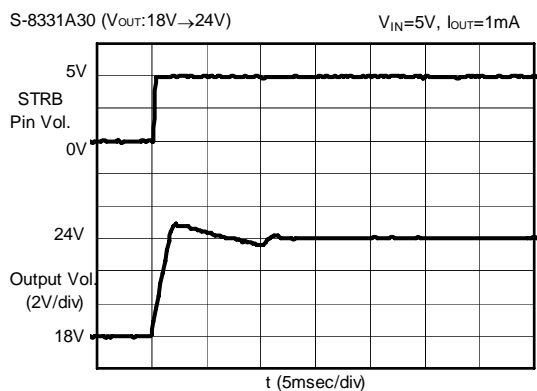
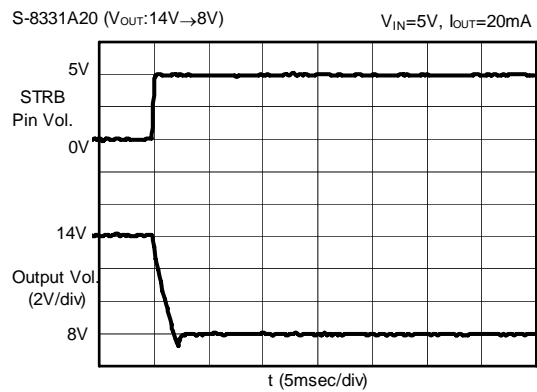
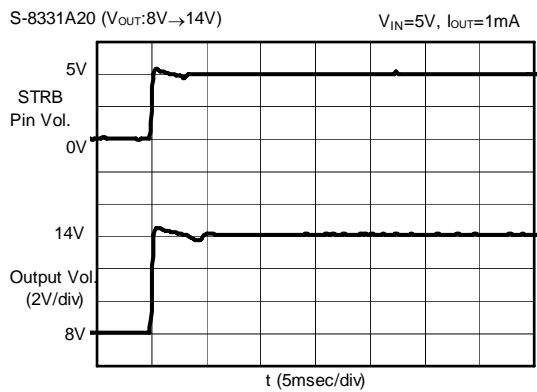
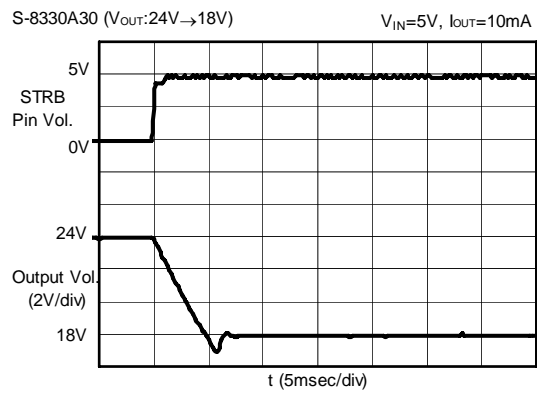
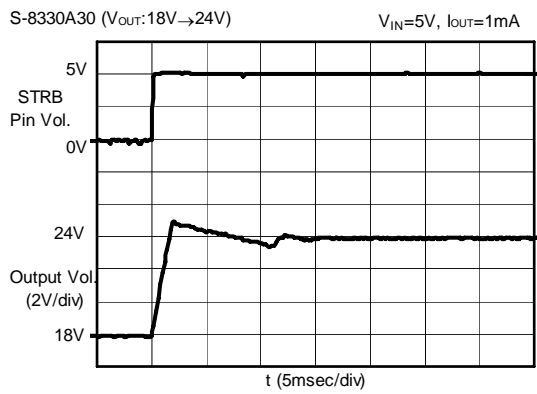
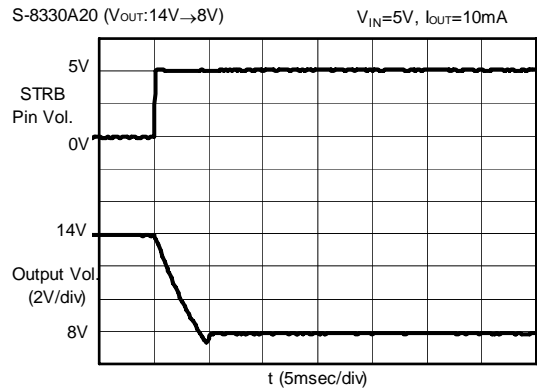
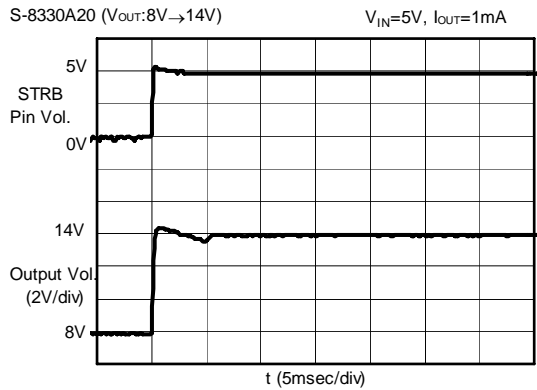

STEP-UP, FOR LCD BIAS SUPPLY, 1-CHANNEL SWITCHING REGULATOR

S-8330/8331 Series

Rev.5.1_00

Reference Data

The reference data is used to properly determine the best external parts. Tables 1 and 2 list characteristic data of parts recommended to respond to the wide variety of applications.

Table 1 Recommended Parts 1

No.	Product	V _{OUT}	L model	Value L	Diode	C _{OUT}	Remark
(1)	S-8330A20	8 V	CD54	47 μH	MA720	4.7 μF×2	Output current, Efficiency
(2)	S-8330A30	18 V	↑	↑	↑	↑	
(3)	↑	30 V	↑	↑	↑	↑	
(4)	S-8330A20	8 V	LQH4N	↑	↑	↑	
(5)	S-8330A30	18 V	↑	↑	↑	↑	
(6)	↑	30 V	↑	↑	↑	↑	
(7)	↑	18 V	↑	22 μH	↑	↑	
(8)	↑	↑	↑	100 μH	↑	↑	
(9)	S-8330B30	↑	↑	100 μH	↑	↑	
(10)	S-8330A20	8 V	CD54	47 μH	↑	↑	Ripple voltage
(11)	S-8330A30	18 V	↑	↑	↑	↑	
(12)	↑	30 V	↑	↑	↑	↑	
(13)	S-8330B30	18 V	LQH4N	100 μH	↑	↑	

Table 2 Recommended Parts 2

Part	Product	Manufacturer	Value L	DC resistor	Max. p. c.	Diameter	Height
Inductor	CD54	Sumida Corporation	22 μH	0.18Ω	1.11A	5.8 mm	4.5 mm
	↑	↑	47 μH	0.37Ω	0.72A	↑	↑
	↑	↑	100 μH	0.70Ω	0.52A	↑	↑
	LQH4N	Murata Manufacturing Co., Ltd.	22 μH	0.94Ω	0.32A	4.5 mm	2.6 mm
	↑	↑	47 μH	1.5Ω	0.22A	↑	↑
	↑	↑	100 μH	2.5Ω	0.16A	↑	↑
	↑	↑	220 μH	5.4Ω	0.11A	↑	↑
Diode	MA720	Matsushita Electric Industrial Co., Ltd.	Forward current 500 mA (VF=0.55 V)				
Output capacitor	F93	Nichicon Corporation					
External transistor	2SD1624	Sanyo Electric Co., Ltd.					

(1)

S-8330A20 (CD54:47μH)

Output Current — Output Voltage Characteristics (Output Current Increase)

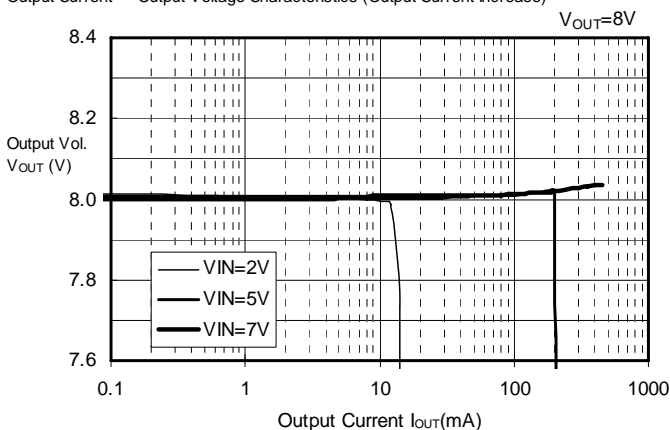

S-8330A20 (CD54:47μH)

Output Current — Efficiency Characteristics (Output Current Increase)

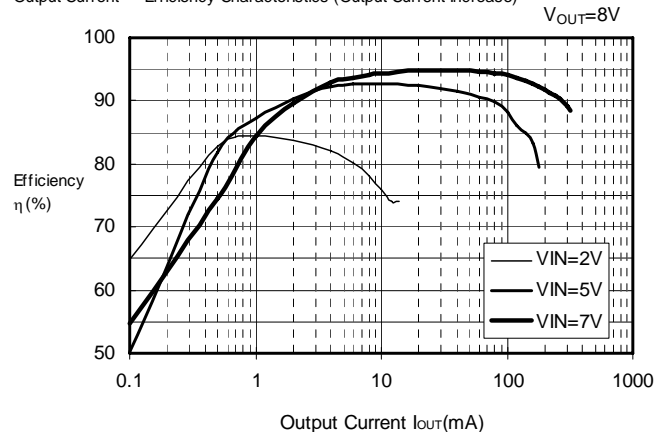

STEP-UP, FOR LCD BIAS SUPPLY, 1-CHANNEL SWITCHING REGULATOR

S-8330/8331 Series

Rev.5.1_00

(2)

S-8330A30 (CD54:47 μ H)

Output Current — Output Voltage Characteristics (Output Current Increase)

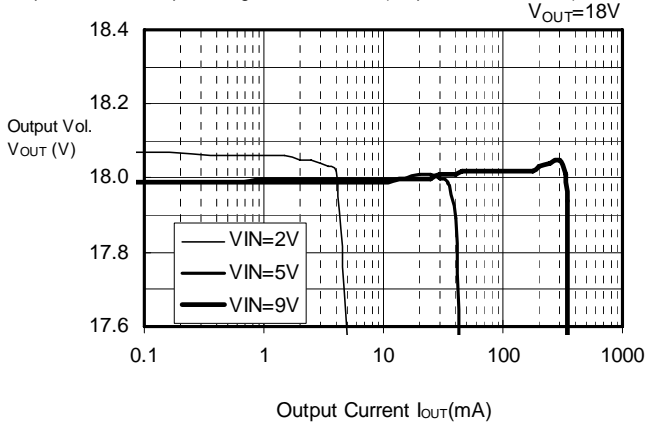

S-8330A30 (CD54:47 μ H)

Output Current — Efficiency Characteristics (Output Current Increase)

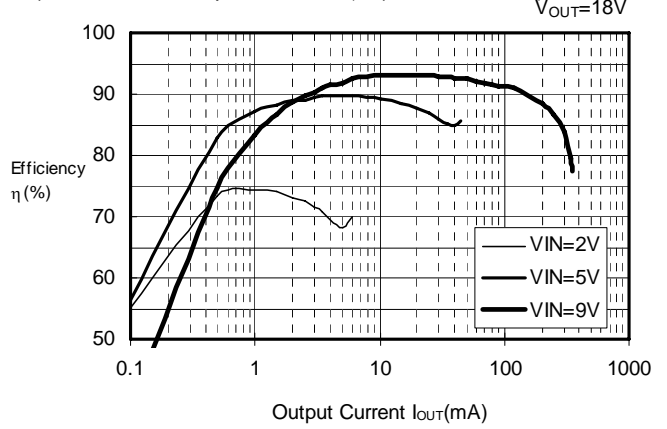

(3)

S-8330A30 (CD54:47 μ H)

Output Current — Output Voltage Characteristics (Output Current Increase)

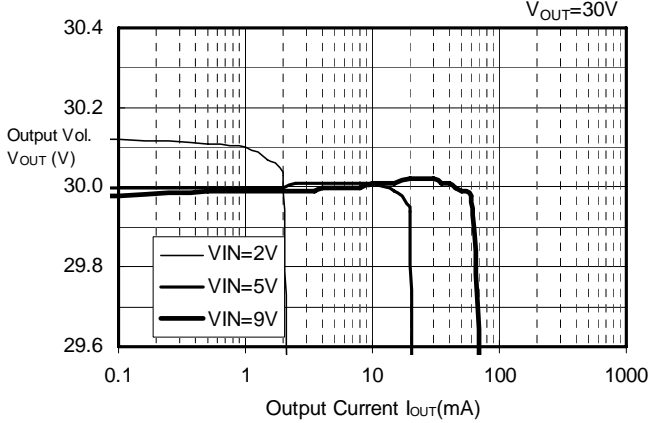

S-8330A30 (CD54:47 μ H)

Output Current — Efficiency Characteristics (Output Current Increase)

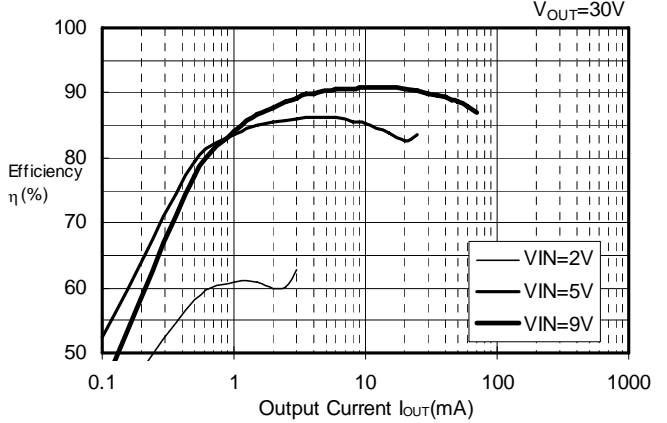

(4)

S-8330A20 (LQH4N:47 μ H)

Output Current — Output Voltage Characteristics (Output Current Increase)

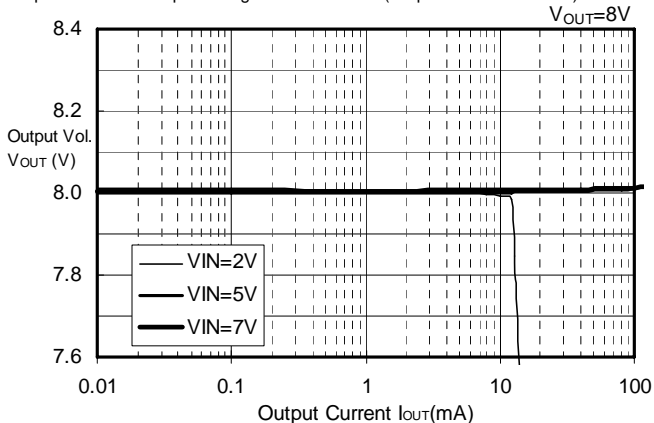

S-8330A20 (LQH4N:47 μ H)

Output Current — Efficiency Characteristics (Output Current Increase)

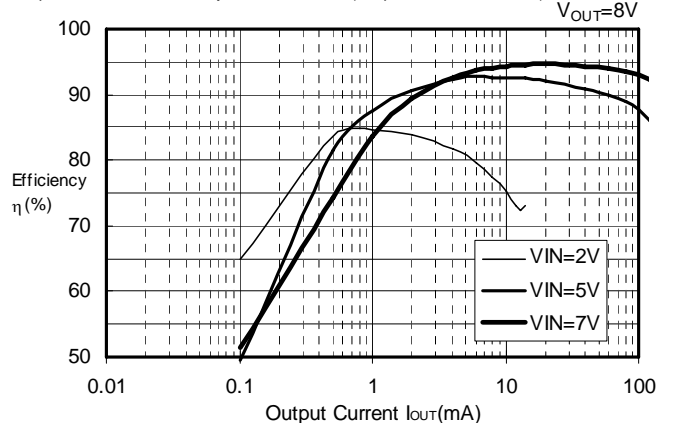

STEP-UP, FOR LCD BIAS SUPPLY, 1-CHANNEL SWITCHING REGULATOR S-8330/8331 Series

Rev.5.1_00

(5)

S-8330A30 (LQH4N:47 μ H)

Output Current — Output Voltage Characteristics (Output Current Increase)

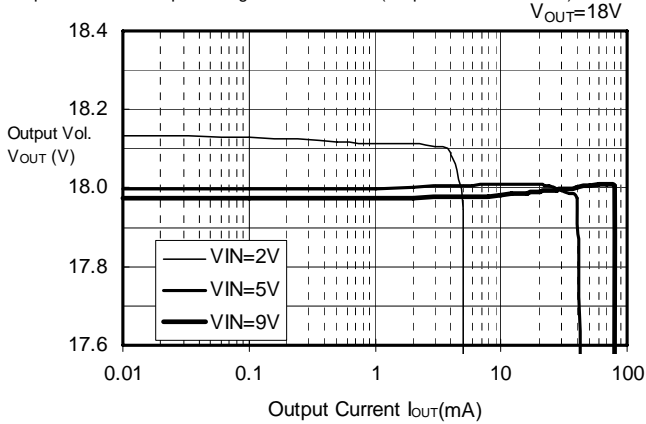

S-8330A30 (LQH4N:47 μ H)

Output Current — Efficiency Characteristics (Output Current Increase)

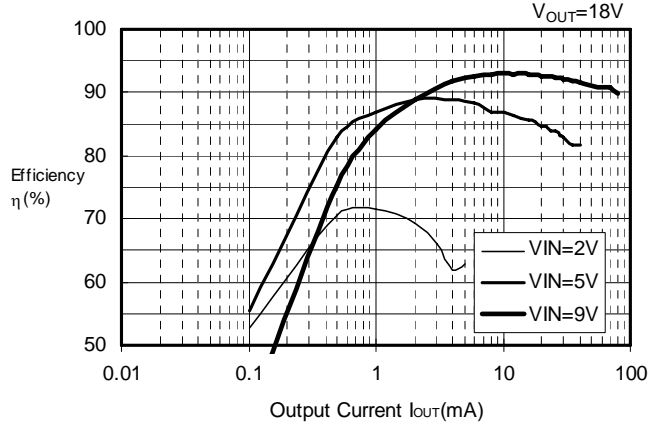

(6)

S-8330A30 (LQH4N:47 μ H)

Output Current — Output Voltage Characteristics (Output Current Increase)

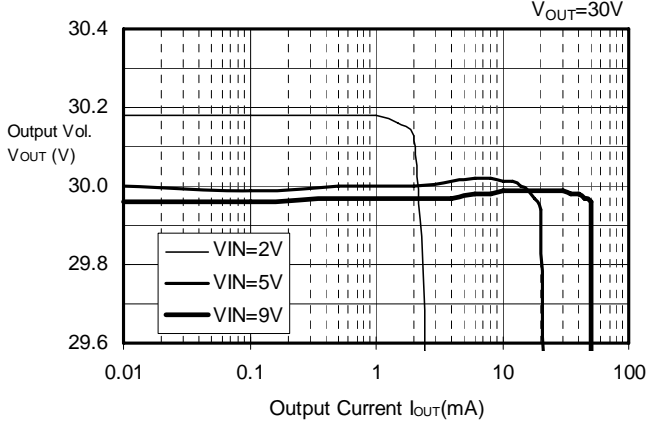

S-8330A30 (LQH4N:47 μ H)

Output Current — Efficiency Characteristics (Output Current Increase)

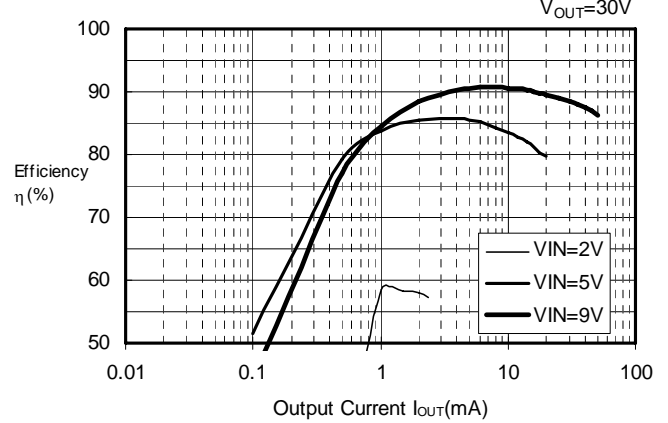

(7)

S-8330A30 (LQH4N:22 μ H)

Output Current — Output Voltage Characteristics (Output Current Increase)

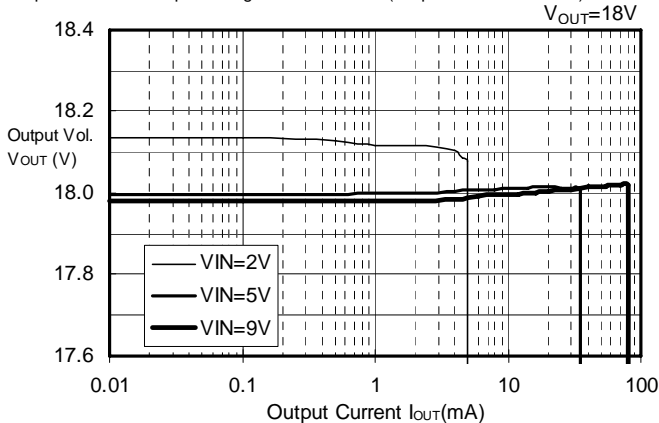

S-8330A30 (LQH4N:22 μ H)

Output Current — Efficiency Characteristics (Output Current Increase)

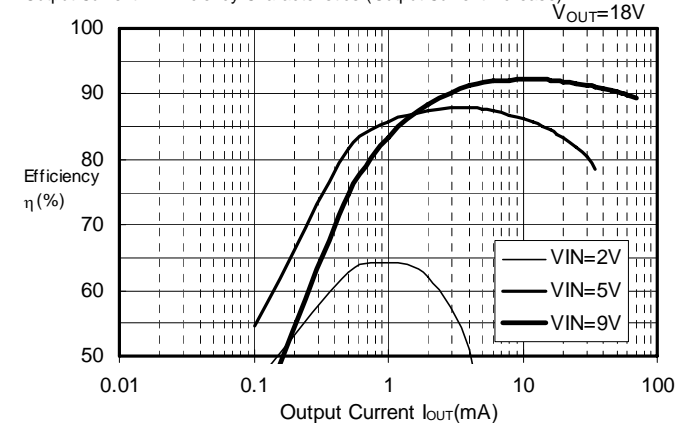

STEP-UP, FOR LCD BIAS SUPPLY, 1-CHANNEL SWITCHING REGULATOR

S-8330/8331 Series

Rev.5.1_00

(8)

S-8330A30 (LQH4N:100 μ H)

Output Current — Output Voltage Characteristics (Output Current Increase)

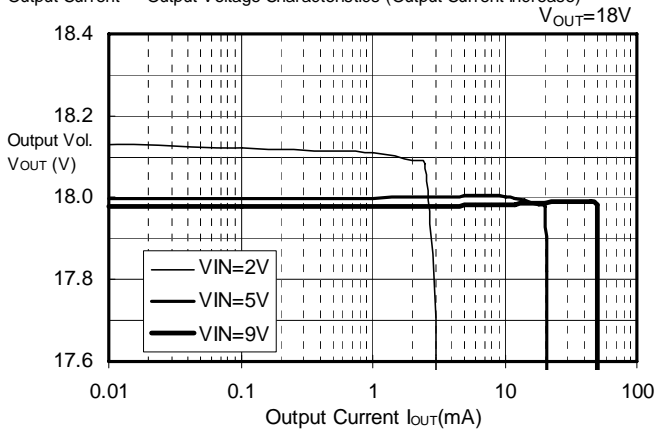

S-8330A30 (LQH4N:100 μ H)

Output Current — Efficiency Characteristics (Output Current Increase)

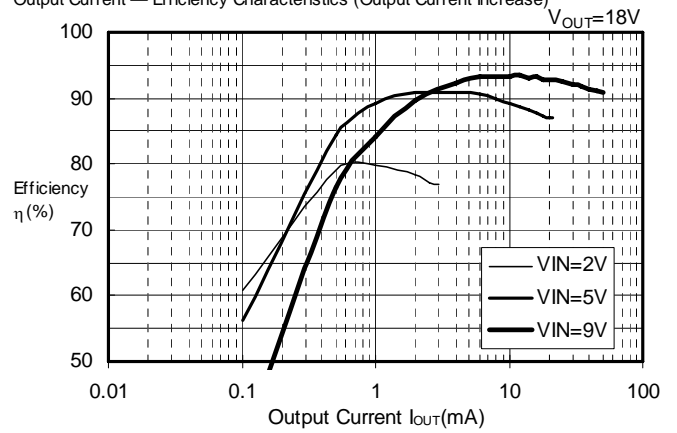

(9)

S-8330B30 (LQH4N:100 μ H)

Output Current — Output Voltage Characteristics (Output Current Increase)

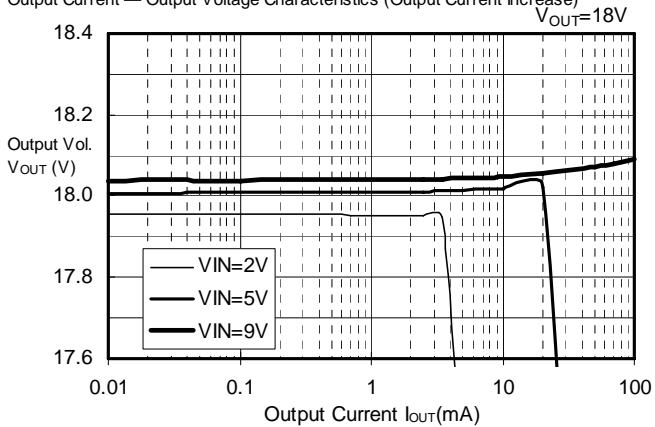

S-8330B30 (LQH4N:100 μ H)

Output Current — Efficiency Characteristics (Output Current Increase)

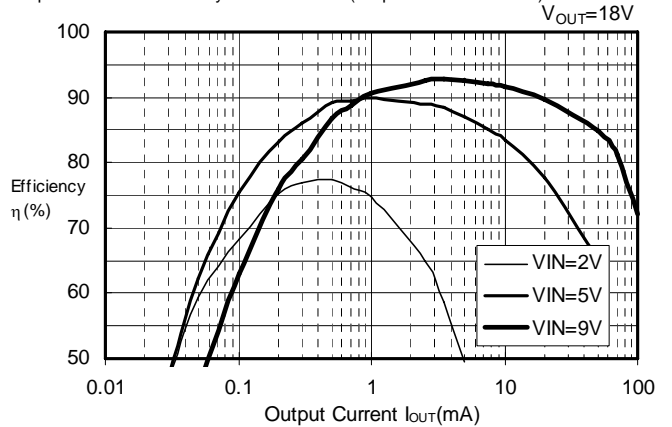

(10)

S-8330A20 (CD54:47 μ H)

Output Current — Ripple Voltage Characteristics (Output Current Increase)

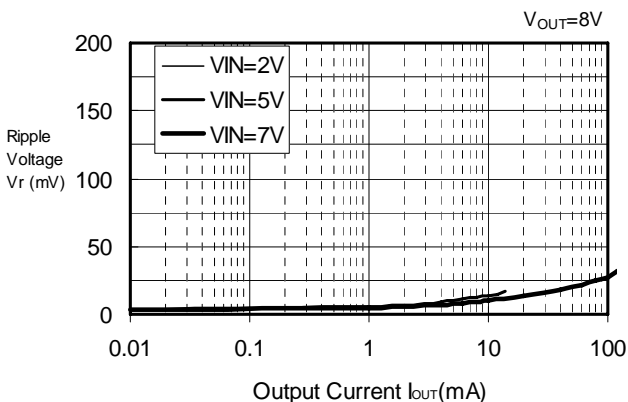

(11)

S-8330A30 (CD54:47 μ H)

Output Current — Ripple Voltage Characteristics (Output Current Increase)

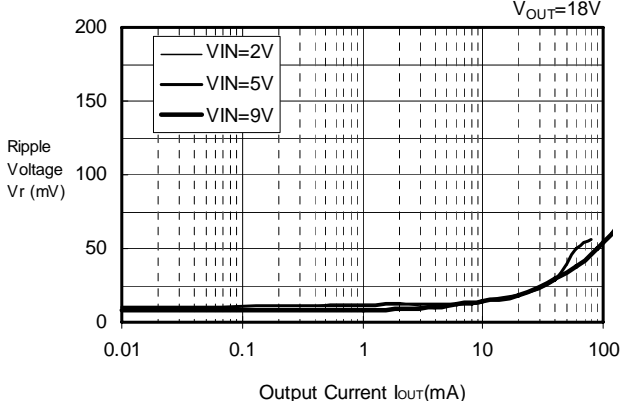

STEP-UP, FOR LCD BIAS SUPPLY, 1-CHANNEL SWITCHING REGULATOR
S-8330/8331 Series

Rev.5.1_00

(12)

S-8330A30 (CD54:47 μ H)

Output Current — Ripple Voltage Characteristics (Output Current Increase)

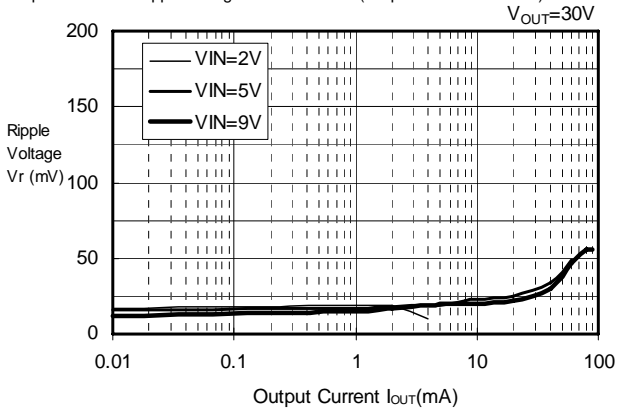

(13)

S-8330B30 (LHQ4N:100 μ H)

Output Current — Ripple Voltage Characteristics (Output Current Increase)

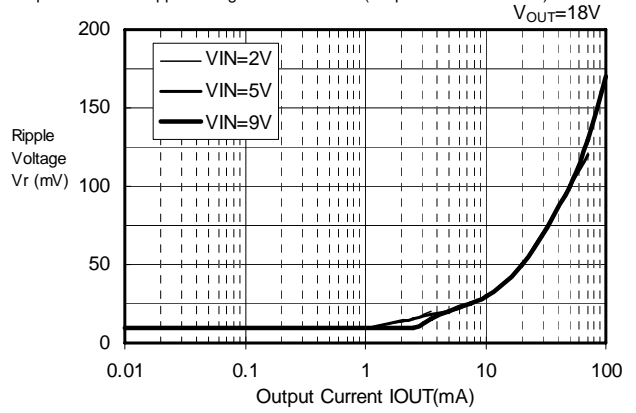

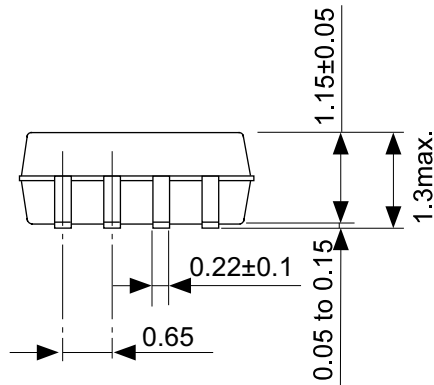
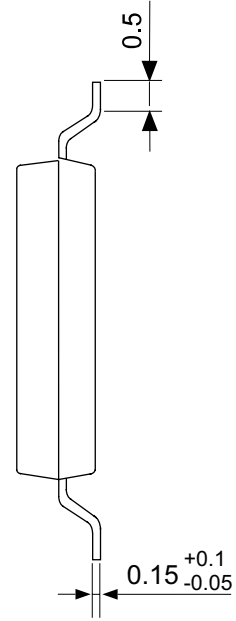
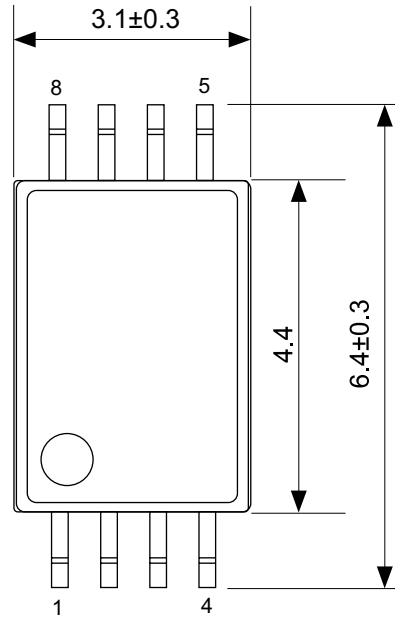

No. FS008-A-P-SD-1.1

TITLE	SSOP8-A-PKG Dimensions
No.	FS008-A-P-SD-1.1
SCALE	
UNIT	mm
Seiko Instruments Inc. www.DataSheet4U.com	

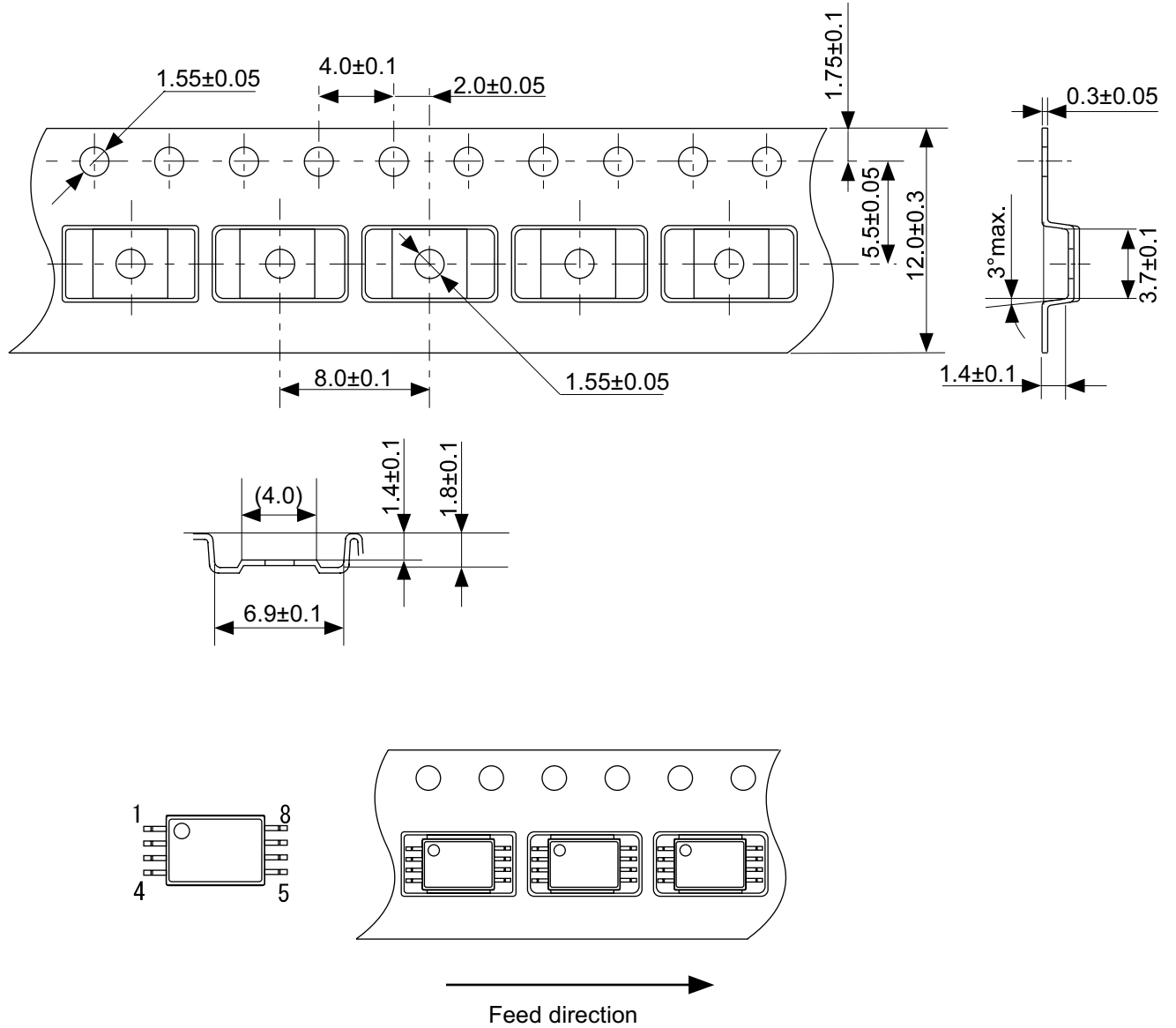

No. FS008-A-C-SD-1.1

TITLE	SSOP8-A-Carrier Tape
No.	FS008-A-C-SD-1.1
SCALE	
UNIT	mm
Seiko Instrument Co., Ltd. www.DataSheet4U.com	

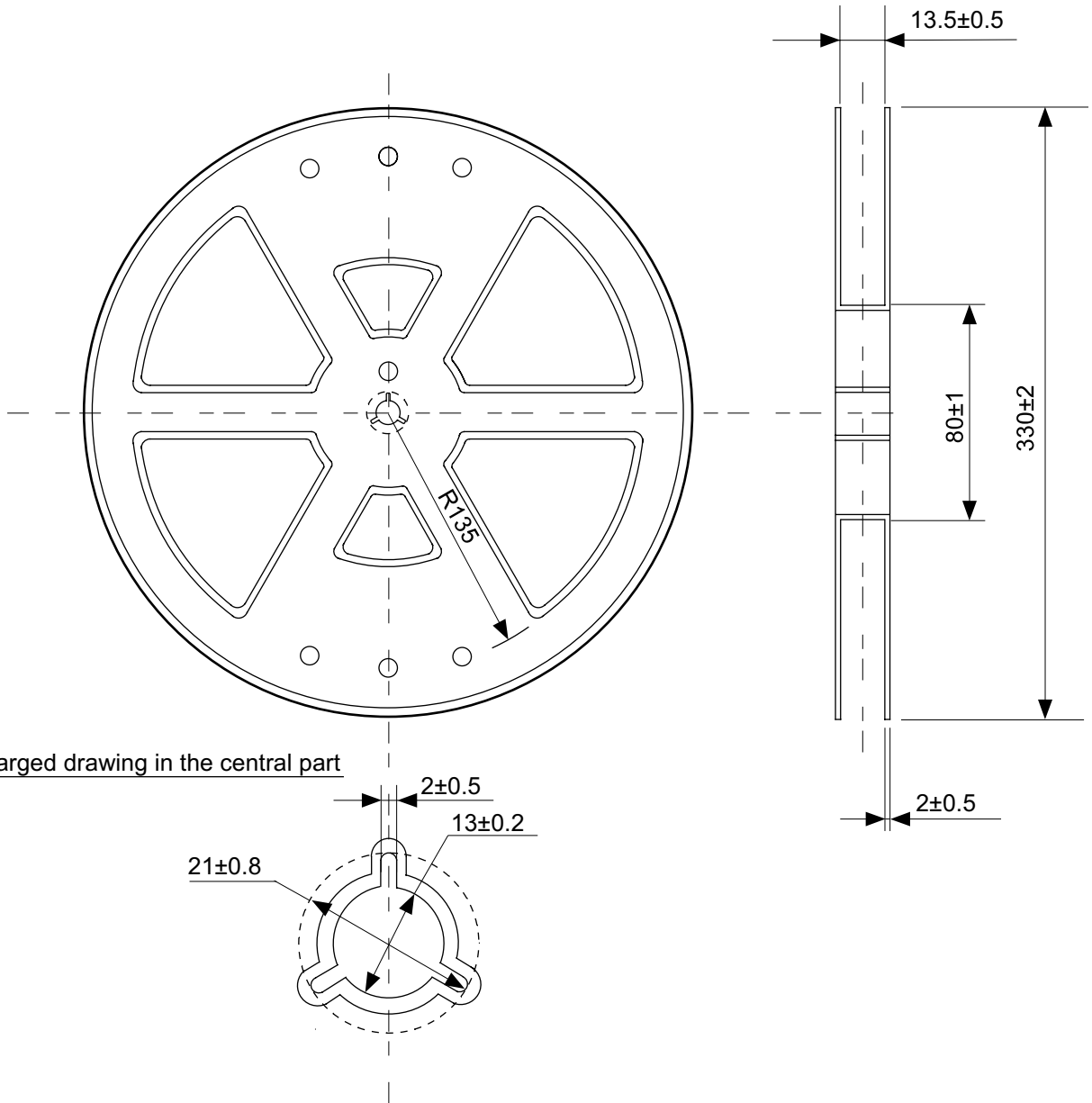

No. FS008-A-R-SD-1.1

TITLE	SSOP8-A-Reel		
No.	FS008-A-R-SD-1.1		
SCALE		QTY.	2,000
UNIT	mm		
Seiko Instruments Inc. www.DataSheet4U.com			

- The information described herein is subject to change without notice.
- Seiko Instruments Inc. is not responsible for any problems caused by circuits or diagrams described herein whose related industrial properties, patents, or other rights belong to third parties. The application circuit examples explain typical applications of the products, and do not guarantee the success of any specific mass-production design.
- When the products described herein are regulated products subject to the Wassenaar Arrangement or other agreements, they may not be exported without authorization from the appropriate governmental authority.
- Use of the information described herein for other purposes and/or reproduction or copying without the express permission of Seiko Instruments Inc. is strictly prohibited.
- The products described herein cannot be used as part of any device or equipment affecting the human body, such as exercise equipment, medical equipment, security systems, gas equipment, or any apparatus installed in airplanes and other vehicles, without prior written permission of Seiko Instruments Inc.
- Although Seiko Instruments Inc. exerts the greatest possible effort to ensure high quality and reliability, the failure or malfunction of semiconductor products may occur. The user of these products should therefore give thorough consideration to safety design, including redundancy, fire-prevention measures, and malfunction prevention, to prevent any accidents, fires, or community damage that may ensue.