

## BATTERY PROTECTION IC FOR 1- CELL PACK

## S-8241 Series

The S-8241 Series is a series of lithium-ion/lithium polymer rechargeable battery protection ICs incorporating high-accuracy voltage detection circuits and delay circuits.

These ICs are suitable for protection of single-cell lithium ion/lithium polymer battery packs from overcharge, overdischarge and overcurrent.

### ■ Features

- (1) Internal high-accuracy voltage detection circuit
  - Overcharge detection voltage: 3.9 V to 4.4 V (5 mV-step)  
Accuracy of  $\pm 25$  mV(+25°C) and  $\pm 30$  mV(-5°C to +55°C)
  - Overcharge release voltage 3.8 V to 4.4 V <sup>\*1</sup> Accuracy of  $\pm 50$  mV
    - \*1. Overcharge release voltage = Overcharge detection voltage - Overcharge hysteresis  
The overcharge hysteresis can be selected in the range 0.0, or 0.1 to 0.4 V in 50mV steps.  
(However, selection "Overcharge release voltage<3.8 V" is enabled.)
  - Overdischarge detection voltage: 2.0 V to 3.0 V (100 mV-step) Accuracy of  $\pm 80$  mV
  - Overdischarge release voltage: 2.0 V to 3.4 V <sup>\*2</sup> Accuracy of  $\pm 100$  mV
    - \*2. Overdischarge release voltage = Overdischarge detection voltage + Overdischarge hysteresis  
The overdischarge hysteresis can be selected in the range 0.0 to 0.7 V in 100mV steps.  
(However, selection "Overdischarge release voltage>3.4 V" is enabled.)
  - Overcurrent 1 detection voltage: 0.05 V to 0.3 V (5 mV-step) Accuracy of  $\pm 20$  mV
  - Overcurrent 2 detection voltage: 0.5 V (fixed) Accuracy of  $\pm 100$  mV
- (2) A high voltage withstand device is used for charger connection pins (VM and CO pins: Absolute maximum rating = 26 V)
- (3) Delay times (overcharge:  $t_{CU}$ ; overdischarge:  $t_{DL}$ ; overcurrent 1:  $t_{OV1}$ ; overcurrent 2:  $t_{OV2}$ ) are generated by an internal circuit. (External capacitors are unnecessary.) Accuracy of  $\pm 30$  %
- (4) Internal three-step overcurrent detection circuit (overcurrent 1, overcurrent 2, and load short-circuiting)
- (5) Either the 0 V battery charging function or 0 V battery charge inhibiting function can be selected.
- (6) Products with and without a power-down function can be selected.
- (7) Charger detection function and abnormal charge current detection function
  - The overdischarge hysteresis is released by detecting a negative VM pin voltage (typ. -1.3 V). (Charger detection function)
  - If the output voltage at DO pin is high and the VM pin voltage becomes equal to or lower than the charger detection voltage (typ. -1.3 V), the output voltage at CO pin goes low. (Abnormal charge current detection function)
- (8) Low current consumption
  - Operation: 3.0  $\mu$ A typ. 5.0  $\mu$ A max.
  - Power-down mode: 0.1  $\mu$ A max.
- (9) Wide operating temperature range: -40 to +85 °C
- (10) Small package SOT-23-5, 5-Pin SON(A)

### ■ Applications

- Lithium-ion rechargeable battery packs
- Lithium- polymer rechargeable battery packs

### ■ Packages

Package name	Drawing code		
	Package	Tape	Reel
SOT-23-5	MP005-A	MP005-A	MP005-A
5-Pin SON(A)	PN005-A	PN005-A	PN005-A

■ **Block Diagram**

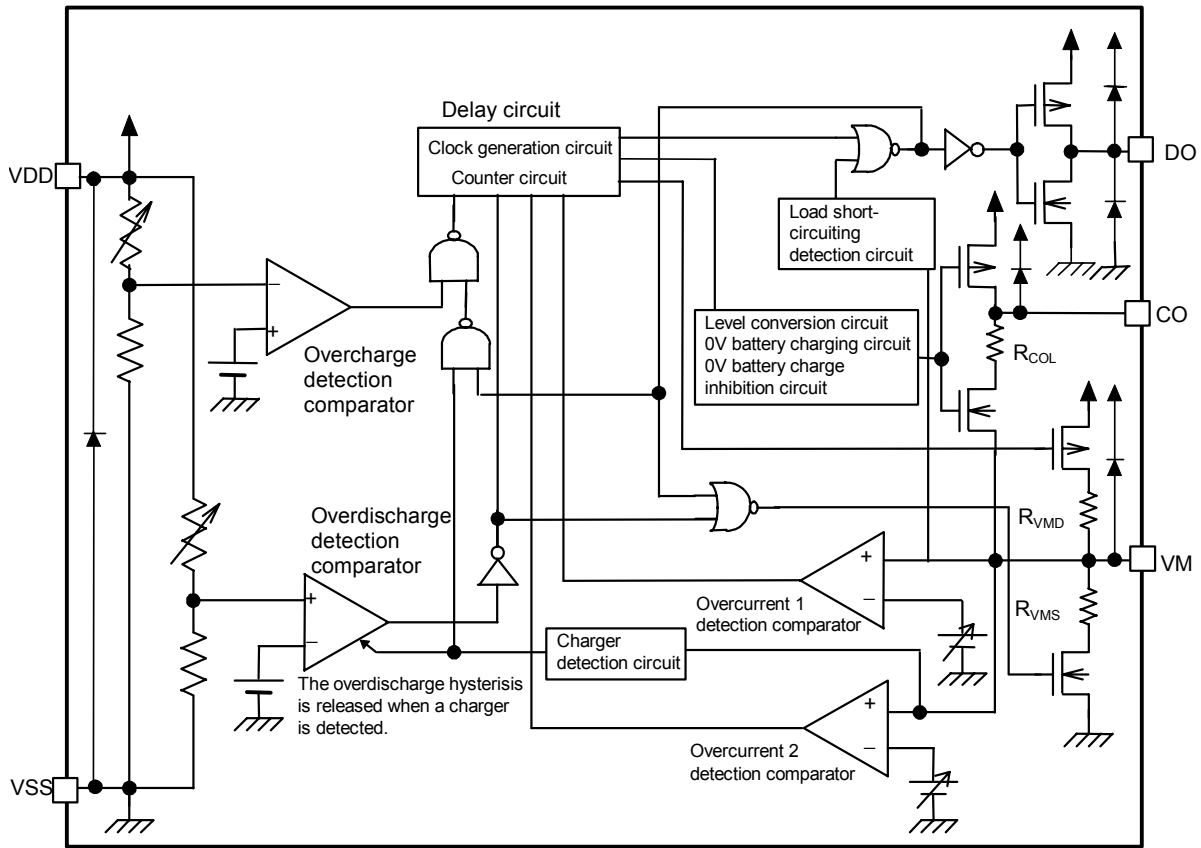

**Remark** The diodes in the IC are parasitic diodes.

**Figure 1 Block Diagram**

■ **Product Code Structure**

**1. Product Name**

**S-8241A** xx xx - xxx xx

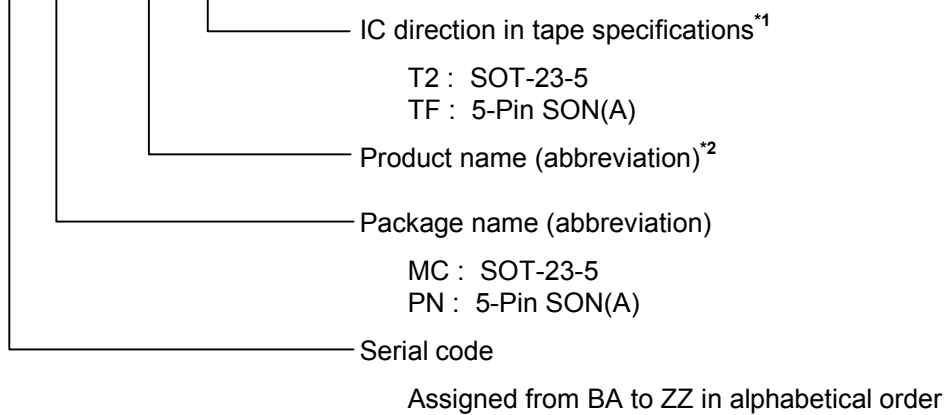

\*<sup>1</sup> Refer to the taping specifications at the end of this book.

\*<sup>2</sup> Refer to the product name list.

2. Product Name List

Model No./Item	Over-charge detection voltage [V <sub>CU</sub> ]	Over-charge release voltage [V <sub>CL</sub> ]	Over-discharge detection voltage [V <sub>DL</sub> ]	Over-discharge release voltage [V <sub>DU</sub> ]	Over-current 1 detection voltage [V <sub>IOV1</sub> ]	0V battery charging function	Delay time combination <sup>*1</sup>	Power down function
S-8241ABAMC-GBA-T2	4.275 V	4.075 V	2.3 V	2.9 V	0.100 V	Unavailable	(1)	Available
S-8241ABBMC-GBB-T2	4.280 V	3.980 V	2.3 V	2.4 V	0.125 V	Available	(2)	Available
S-8241ABCMC-GBC-T2	4.350 V	4.100 V	2.3 V	2.8 V	0.075 V	Unavailable	(1)	Available
S-8241ABDMC-GBD-T2	4.275 V	4.175 V	2.3 V	2.4 V	0.100 V	Available	(1)	Available
S-8241ABDPN-KBD-TF								
S-8241ABEMC-GBE-T2	4.295 V	4.095 V	2.3 V	3.0 V	0.200 V	Unavailable	(1)	Available
S-8241ABFMC-GBF-T2	4.325 V	4.075 V	2.5 V	2.9 V	0.100 V	Unavailable	(1)	Available
S-8241ABGMC-GBG-T2	4.200 V	4.100 V	2.3 V	3.0 V	0.100 V	Unavailable	(1)	Available
S-8241ABHMC-GBH-T2	4.325 V	4.125 V	2.3 V	2.3 V	0.100 V	Available	(1)	Available
S-8241ABIMC-GBI-T2	4.280 V	4.080 V	2.3 V	2.3 V	0.160 V	Unavailable	(1)	Available
S-8241ABKMC-GBK-T2	4.325 V	4.075 V	2.5 V	2.9 V	0.150 V	Unavailable	(1)	Available
S-8241ABLMC-GBL-T2	4.320 V	4.070 V	2.5 V	2.9 V	0.100 V	Unavailable	(1)	Available
S-8241ABNPN-KBN-TF	4.350 V	4.050 V	2.35 V	2.65 V	0.150 V	Available	(1)	Available
S-8241ABOMC-GBO-T2	4.350 V	4.15 V	2.3 V	3.0 V	0.150 V	Available	(2)	Available
S-8241ABPMC-GBP-T2	4.350 V	4.15 V	2.3 V	3.0 V	0.200 V	Available	(2)	Available
S-8241ABQMC-GBQ-T2	4.280 V	4.080 V	2.3 V	2.3 V	0.130 V	Unavailable	(1)	Available
S-8241ABSPN-KBS-TF	4.350 V	4.150 V	2.35 V	2.65 V	0.200 V	Available	(2)	Available
S-8241ABTPN-KBT-TF	4.300 V	4.100 V	2.3 V	2.3 V	0.100 V	Available	(1)	Available
S-8241ABUMC-GBU-T2	4.200 V	4.100 V	2.3 V	2.3 V	0.150 V	Unavailable	(1)	Available
S-8241ABVMC-GBV-T2	4.295 V	4.095 V	2.3 V	2.3 V	0.130 V	Available	(1)	Available
S-8241ABWMC-GBW-T2	4.280 V	4.080 V	2.3 V	2.3 V	0.130 V	Unavailable	(3)	Available
S-8241ABXMC-GBX-T2	4.350 V	4.000 V	2.6 V	3.3 V	0.200 V	Unavailable	(1)	Available
S-8241ABXPN-KBX-TF								
S-8241ABYMC-GBY-T2	4.220 V	4.220 V	2.3 V	2.3 V	0.200 V	Available	(3)	Available
S-8241ABZPN-KBZ-TF	4.275 V	4.075 V	2.3 V	2.4 V	0.140 V	Available	(1)	Available
S-8241ACAMC-GCA-T2	4.280 V	4.080 V	2.3 V	2.3 V	0.200 V	Available	(1)	Available
S-8241ACAPN-KCA-TF								
S-8241ACBMC-GCB-T2	4.300 V	4.100 V	2.3 V	2.3 V	0.150 V	Available	(1)	Available
S-8241ACDMC-GCD-T2	4.275 V	4.075 V	2.3 V	2.3 V	0.100 V	Unavailable	(4)	Available
S-8241ACEMC-GCE-T2	4.295 V	4.095 V	2.3 V	2.3 V	0.080 V	Available	(1)	Available
S-8241ACFMC-GCF-T2	4.295 V	4.095 V	2.3 V	2.3 V	0.090 V	Available	(1)	Available
S-8241ACGMC-GCG-T2	4.295 V	4.095 V	2.3 V	2.3 V	0.060 V	Available	(1)	Available
S-8241ACGPN-KCG-TF								
S-8241ACHMC-GCH-T2	4.280 V	4.080 V	2.6 V	2.6 V	0.200 V	Available	(1)	Available
S-8241ACIMC-GCI-T2	4.350 V	4.150 V	2.05 V	2.75 V	0.200 V	Available	(2)	Available
S-8241ACJPN-KCJ-TF	4.300 V	4.100 V	2.3 V	2.3 V	0.120 V	Available	(1)	Available
S-8241ACKMC-GCK-T2	4.350 V	4.150 V	2.0 V	2.0 V	0.200 V	Available	(2)	Available
S-8241ACLMC-GCL-T2	4.200 V	4.200 V	2.5 V	3.0 V	0.100 V	Available	(1)	Available
S-8241ACNMC-GCN-T2	4.350 V	4.150 V	2.1 V	2.2 V	0.200 V	Available	(2)	Available
S-8241ACNPN-KCN-TF								

# BATTERY PROTECTION IC FOR 1-CELL PACK

## S-8241 Series

Rev.4.1\_01

Model No./Item	Over-charge detection voltage [V <sub>CU</sub> ]	Over-charge release voltage [V <sub>CL</sub> ]	Over-discharge detection voltage [V <sub>DL</sub> ]	Over-discharge release voltage [V <sub>DU</sub> ]	Over-current 1 detection voltage [V <sub>IOV1</sub> ]	0V battery charging function	Delay time combination <sup>*1</sup>	Power down function
S-8241ACOMC-GCO-T2	4.100 V	3.850 V	2.5 V	2.9 V	0.150 V	Unavailable	(1)	Unavailable
S-8241ACPMC-GCP-T2	4.325 V	4.075 V	2.5 V	2.9 V	0.150 V	Unavailable	(1)	Unavailable
S-8241ACQMC-GCQ-T2	4.275 V	4.175 V	2.3 V	2.4 V	0.100 V	Available	(1)	Unavailable
S-8241ACRMC-GCR-T2	4.350 V	4.150 V	2.3 V	3.0 V	0.100 V	Available	(1)	Unavailable
S-8241ACSMC-GCS-T2	4.180 V	3.930 V	2.5 V	2.9 V	0.150 V	Unavailable	(1)	Unavailable
S-8241ACTMC-GCT-T2	4.100 V	4.000 V	2.5 V	2.9 V	0.150 V	Unavailable	(1)	Unavailable
S-8241ACUMC-GCU-T2	4.180 V	4.080 V	2.5 V	2.9 V	0.150 V	Unavailable	(1)	Unavailable
S-8241ACXMC-GCX-T2	4.275 V	4.075 V	2.5 V	2.9 V	0.150 V	Unavailable	(1)	Unavailable
S-8241ACYMC-GCY-T2	4.275 V	4.075 V	2.6 V	2.9 V	0.100 V	Unavailable	(1)	Unavailable
S-8241ACZPN-KCZ-TF	4.350 V	4.150 V	2.7 V	2.7 V	0.200 V	Unavailable	(2)	Available
S-8241ADAMC-GDA-T2	4.350 V	4.150 V	2.3 V	3.0 V	0.100 V	Available	(1)	Available
S-8241ADBPN-KDB-TF	4.280 V	4.080 V	2.3 V	2.3 V	0.250 V	Unavailable	(2)	Available

\*1. The delay time combination (1), (2), (3), (4) is as follows.

Delay time combination	Overcharge detection delay time	Overdischarge detection delay time	Overcurrent 1 detection delay time
(1)	1.0 s	125 ms	8 ms
(2)	0.125 s	31 ms	16 ms
(3)	0.25 s	125 ms	8 ms
(4)	2.0 s	125 ms	8 ms

It is possible to change the detection voltage for products other than those listed above. Also, delay time can be changed within the following range. For details, please contact our sales office.

Delay time	Symbol	Optional range			Remarks
Overcharge detection delay time	t <sub>CU</sub>	0.25 s	0.5 s	1.0 s	Choose from the list at left.
Overdischarge detection delay time	t <sub>DL</sub>	31 ms	62.5 ms	125 ms	Choose from the list at left.
Overcurrent 1 detection delay time	t <sub>IOV1</sub>	4 ms	8 ms	16 ms	Choose from the list at left.

Shaded boxes indicate standard values.

■ **Pin Configurations**

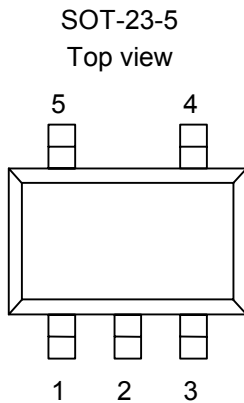

**Figure 2**

Pin No.	Symbol	Pin Description
1	VM	Voltage detection pin between VM and VSS (Overcurrent detection pin)
2	VDD	Positive power input pin
3	VSS	Negative power input pin
4	DO	FET gate connection pin for discharge control (CMOS output)
5	CO	FET gate connection pin for charge control (CMOS output)

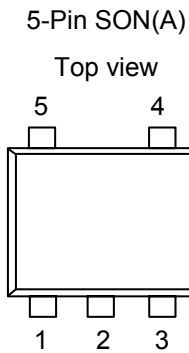

**Figure 3**

Pin No.	Symbol	Pin Description
1	VM	Voltage detection pin between VM and VSS (Overcurrent detection pin)
2	VDD	Positive power input pin
3	CO	FET gate connection pin for charge control (CMOS output)
4	DO	FET gate connection pin for discharge control (CMOS output)
5	VSS	Negative power input pin

**Remark** Pin assignment of SOT-23-5 and of 5-Pin SON(A) are different.

■ **Absolute Maximum Ratings**

(Ta = 25°C unless otherwise specified)

Item	Symbol	Applicable pin	Rating	Unit	
Input voltage between VDD and VSS *1	V <sub>DS</sub>	VDD	V <sub>SS</sub> -0.3 to V <sub>SS</sub> +12	V	
VM Input pin voltage	V <sub>VM</sub>	VM	V <sub>DD</sub> -26 to V <sub>DD</sub> +0.3	V	
CO output pin voltage	V <sub>CO</sub>	CO	V <sub>VM</sub> -0.3 to V <sub>DD</sub> +0.3	V	
DO output pin voltage	V <sub>DO</sub>	DO	V <sub>SS</sub> -0.3 to V <sub>DD</sub> +0.3	V	
Power dissipation	P <sub>D</sub>	-	SOT-23-5	250	mW
			5-Pin SON(B)	150	
Operation ambient temperature	Topr	-	-40 to +85	°C	
Storage temperature	Tstg	-	-40 to +125	°C	

\*1. Do not apply pulse-like noise of μs order exceeding the above input voltage (V<sub>SS</sub> + 12 V). The noise causes damage to the IC.

**Caution** The absolute maximum ratings are rated values exceeding which the product could suffer physical damage. These values must therefore not be exceeded under any conditions.

■ **Electrical Characteristics (1) Other than detection delay time (25°C)**

(Ta = 25°C unless otherwise specified)

Item	Symbol	Measurement conditions	Remarks	Min.	Typ.	Max.	Unit	Measurement circuit
<b>DETECTION VOLTAGE</b>								
Overcharge detection voltage V <sub>CU</sub> =3.9 to 4.4 V, 5 mV Step	V <sub>CU</sub>	1	–	V <sub>CU</sub> -0.025	V <sub>CU</sub>	V <sub>CU</sub> +0.025	V	1
			Ta= -5°C to 55°C <sup>*1</sup>	V <sub>CU</sub> -0.030	V <sub>CU</sub>	V <sub>CU</sub> +0.030		
Overcharge release voltage V <sub>CU</sub> -V <sub>CL</sub> =0 to 0.4 V, 50mV Step	V <sub>CL</sub>	1	When V <sub>CL</sub> ≠ V <sub>CU</sub>	V <sub>CL</sub> -0.050	V <sub>CL</sub>	V <sub>CL</sub> +0.050	V	1
			When V <sub>CL</sub> = V <sub>CU</sub>	V <sub>CL</sub> -0.025	V <sub>CL</sub>	V <sub>CL</sub> +0.025		
Overdischarge detection voltage V <sub>DL</sub> =2.0 to 3.0 V, 100mV Step	V <sub>DL</sub>	1	–	V <sub>DL</sub> -0.080	V <sub>DL</sub>	V <sub>DL</sub> +0.080	V	1
Overdischarge release voltage V <sub>DU</sub> -V <sub>DL</sub> =0 to 0.7 V, 100mV Step	V <sub>DU</sub>	1	When V <sub>DU</sub> ≠ V <sub>DL</sub>	V <sub>DU</sub> -0.100	V <sub>DU</sub>	V <sub>DU</sub> +0.100		
			When V <sub>DU</sub> = V <sub>DL</sub>	V <sub>DU</sub> -0.080	V <sub>DU</sub>	V <sub>DU</sub> +0.080	V	1
Overcurrent 1 detection voltage V <sub>IOV1</sub> =0.05 to 0.3V, 5mV Step	V <sub>IOV1</sub>	2	–	V <sub>IOV1</sub> -0.02 0	V <sub>IOV1</sub>	V <sub>IOV1</sub> +0.02 0	V	1
Overcurrent 2 detection voltage	V <sub>IOV2</sub>	2	–	0.4	0.5	0.6	V	1
Load short-circuiting detection voltage	V <sub>SHORT</sub>	2	VM voltage based on V <sub>DD</sub>	-1.7	-1.3	-0.9	V	1
Charger detection voltage	V <sub>CHA</sub>	3	–	-2.0	-1.3	-0.6	V	1
Overcharge detection voltage temperature factor <sup>*1</sup>	T <sub>COE1</sub>	–	Ta= -5°C to 55°C	-0.5	0	0.5	mV/°C	–
Overcurrent 1 detection voltage temperature factor <sup>*1</sup>	T <sub>COE2</sub>	–	Ta= -5°C to 55°C	-0.1	0	0.1	mV/°C	–
<b>INPUT VOLTAGE, OPERATING VOLTAGE</b>								
Input voltage between VDD and VSS	V <sub>DS1</sub>	–	absolute maximum rating	-0.3	–	12	V	–
Input voltage between VDD and VM	V <sub>DS2</sub>	–	absolute maximum rating	-0.3	–	26	V	–
Operating voltage between VDD and VSS	V <sub>DSOP1</sub>	–	Internal circuit operating voltage	1.5	–	8	V	–
Operating voltage between VDD and VM	V <sub>DSOP2</sub>	–	Internal circuit operating voltage	1.5	–	24	V	–
<b>CURRENT CONSUMPTION Power-down function available</b>								
Current consumption during normal operation	I <sub>OPE</sub>	4	V <sub>DD</sub> =3.5V, V <sub>VM</sub> =0 V	1.0	3.0	5.0	μA	1
Current consumption at power down	I <sub>PDN</sub>	4	V <sub>DD</sub> =V <sub>VM</sub> =1.5 V	–	–	0.1	μA	1
<b>CURRENT CONSUMPTION Power-down function unavailable</b>								
Current consumption during normal operation	I <sub>OPE</sub>	4	V <sub>DD</sub> =3.5 V, V <sub>VM</sub> =0 V	1.0	3.0	5.0	μA	1
Overdischarge current consumption	I <sub>OPEd</sub>	4	V <sub>DD</sub> =V <sub>VM</sub> =1.5 V	1.0	2.0	3.5	μA	1
<b>OUTPUT RESISTANCE</b>								
CO pin H resistance	R <sub>COH</sub>	6	V <sub>CO</sub> =3.0 V, V <sub>DD</sub> =3.5 V, V <sub>VM</sub> =0 V	0.1	2	10	kΩ	1
CO pin L resistance	R <sub>COL</sub>	6	V <sub>CO</sub> =0.5 V, V <sub>DD</sub> =4.5 V, V <sub>VM</sub> =0 V	150	600	2400	kΩ	1
DO pin H resistance	R <sub>DOH</sub>	7	V <sub>DO</sub> =3.0 V, V <sub>DD</sub> =3.5 V, V <sub>VM</sub> =0 V	0.1	1.3	6.0	kΩ	1
DO pin L resistance	R <sub>DOL</sub>	7	V <sub>DO</sub> =0.5 V, V <sub>DD</sub> =V <sub>VM</sub> =1.8 V	0.1	0.5	2.0	kΩ	1
<b>VM INTERNAL RESISTANCE</b>								
Internal resistance between VM and VDD	R <sub>VMD</sub>	5	V <sub>DD</sub> =1.8 V, V <sub>VM</sub> =0 V	100	300	900	kΩ	1
Internal resistance between VM and VSS	R <sub>VMS</sub>	5	V <sub>DD</sub> =V <sub>VM</sub> =3.5 V	50	100	150	kΩ	1
<b>0 V BATTERY CHARGING FUNCTION</b> The 0 V battery function is either "0 V battery charging function" or "0 V battery charge inhibiting function" depending upon the product type.								
0 V battery charge starting charger voltage	V <sub>OCHA</sub>	10	0 V battery charging Available	0.0	0.8	1.5	V	1
0 V battery charge inhibiting battery voltage	V <sub>OINH</sub>	11	0 V battery charging Unavailable	0.6	0.9	1.2	V	1

\*1. Since products are not screened at high and low temperatures, the specification for this temperature range is guaranteed by design, not tested in production.

# BATTERY PROTECTION IC FOR 1-CELL PACK S-8241 Series

Rev.4.1\_01

## ■ Electrical Characteristics (2) Other than detection delay time (-40 to 85°C\*1)

(Ta = (-40 to 85°C\*1) unless otherwise specified)

Item	Symbol	Measurement conditions	Remarks	Min.	Typ.	Max.	Unit	Measurement circuit
<b>DETECTION VOLTAGE</b>								
Overcharge detection voltage V <sub>CU</sub> =3.9 to 4.4 V, 5mV Step	V <sub>CU</sub>	1	–	V <sub>CU</sub> -0.055	V <sub>CU</sub>	V <sub>CU</sub> +0.040	V	1
Overcharge release voltage V <sub>CU</sub> -V <sub>CL</sub> =0 to 0.4 V, 50mV Step	V <sub>CL</sub>	1	When V <sub>CL</sub> ≠ V <sub>CU</sub>	V <sub>CL</sub> -0.095	V <sub>CL</sub>	V <sub>CL</sub> +0.060	V	1
			When V <sub>CL</sub> = V <sub>CU</sub>	V <sub>CL</sub> -0.055	V <sub>CL</sub>	V <sub>CL</sub> +0.040		
Overdischarge detection voltage V <sub>DL</sub> =2.0 to 3.0 V, 100mV Step	V <sub>DL</sub>	1	–	V <sub>DL</sub> -0.120	V <sub>DL</sub>	V <sub>DL</sub> +0.120	V	1
Overdischarge release voltage V <sub>DU</sub> -V <sub>DL</sub> =0 to 0.7 V, 100mV Step	V <sub>DU</sub>	1	When V <sub>DU</sub> ≠ V <sub>DL</sub>	V <sub>DU</sub> -0.140	V <sub>DU</sub>	V <sub>DU</sub> +0.140	V	1
			When V <sub>DU</sub> = V <sub>DL</sub>	V <sub>DU</sub> -0.120	V <sub>DU</sub>	V <sub>DU</sub> +0.120		
Overcurrent 1 detection voltage V <sub>IOV1</sub> =0.05 to 0.3V, 5mV Step	V <sub>IOV1</sub>	2	–	V <sub>IOV1</sub> -0.026	V <sub>IOV1</sub>	V <sub>IOV1</sub> +0.026	V	1
Overcurrent 2 detection voltage	V <sub>IOV2</sub>	2	–	0.37	0.5	0.63	V	1
Load short-circuiting detection voltage	V <sub>SHORT</sub>	2	VM voltage based on V <sub>DD</sub>	-1.9	-1.3	-0.7	V	1
Charger detection voltage	V <sub>CHA</sub>	3	–	-2.2	-1.3	-0.4	V	1
Overcharge detection voltage temperature factor*1	T <sub>COE1</sub>	–	Ta= -40°C to 85°C	-0.7	0	0.7	mV/°C	–
Overcurrent 1 detection voltage temperature factor*1	T <sub>COE2</sub>	–	Ta= -40°C to 85°C	-0.2	0	0.2	mV/°C	–
<b>INPUT VOLTAGE, OPERATING VOLTAGE</b>								
Input voltage between VDD and VSS	V <sub>DS1</sub>	–	absolute maximum rating	-0.3	–	12	V	–
Input voltage between VDD and VM	V <sub>DS2</sub>	–	absolute maximum rating	-0.3	–	26	V	–
Operating voltage between VDD and VSS	V <sub>DSOP1</sub>	–	Internal circuit operating voltage	1.5	–	8	V	–
Operating voltage between VDD and VM	V <sub>DSOP2</sub>	–	Internal circuit operating voltage	1.5	–	24	V	–
<b>CURRENT CONSUMPTION Power-down function available</b>								
Current consumption during normal operation	I <sub>OPE</sub>	4	V <sub>DD</sub> =3.5 V, V <sub>VM</sub> =0 V	0.7	3.0	6.0	μA	1
Current consumption at power down	I <sub>PDN</sub>	4	V <sub>DD</sub> =V <sub>VM</sub> =1.5 V	–	–	0.1	μA	1
<b>CURRENT CONSUMPTION Power-down function unavailable</b>								
Current consumption during normal operation	I <sub>OPE</sub>	4	V <sub>DD</sub> =3.5 V, V <sub>VM</sub> =0 V	0.7	3.0	6.0	μA	1
Overdischarge current consumption	I <sub>OPEd</sub>	4	V <sub>DD</sub> =V <sub>VM</sub> =1.5 V	0.6	2.0	4.5	μA	1
<b>OUTPUT RESISTANCE</b>								
CO pin H resistance	R <sub>COH</sub>	6	V <sub>CO</sub> =3.0 V, V <sub>DD</sub> =3.5 V, V <sub>VM</sub> =0 V	0.07	2	13	kΩ	1
CO pin L resistance	R <sub>COL</sub>	6	V <sub>CO</sub> =0.5 V, V <sub>DD</sub> =4.5 V, V <sub>VM</sub> =0 V	100	600	3500	kΩ	1
DO pin H resistance	R <sub>DOH</sub>	7	V <sub>DO</sub> =3.0 V, V <sub>DD</sub> =3.5 V, V <sub>VM</sub> =0 V	0.07	1.3	7.3	kΩ	1
DO pin L resistance	R <sub>DOL</sub>	7	V <sub>DO</sub> =0.5 V, V <sub>DD</sub> =V <sub>VM</sub> =1.8 V	0.07	0.5	2.5	kΩ	1
<b>VM INTERNAL RESISTANCE</b>								
Internal resistance between VM and VDD	R <sub>VMD</sub>	5	V <sub>DD</sub> =1.8 V, V <sub>VM</sub> =0 V	78	300	1310	kΩ	1
Internal resistance between VM and VSS	R <sub>VMS</sub>	5	V <sub>DD</sub> =V <sub>VM</sub> =3.5 V	39	100	220	kΩ	1
<b>0 V BATTERY CHARGING FUNCTION</b> The 0 V battery function is either "0 V battery charging function" or "0 V battery charge inhibiting function" depending upon the product type.								
0 V battery charge starting charger voltage	V <sub>OCHA</sub>	10	0 V battery charging Available	0.0	0.8	1.7	V	1
0 V battery charge inhibiting battery voltage	V <sub>OINH</sub>	11	0 V battery charging Unavailable	0.4	0.9	1.4	V	1

\*1. Since products are not screened at high and low temperatures, the specification for this temperature range is guaranteed by design, not tested in production.

■ **Electrical Characteristics (3) Detection delay time (25°C)**

(Ta = 25°C unless otherwise specified)

Item	Symbol	Measurement conditions	Remarks	Min.	Typ.	Max.	Unit	Measurement circuit
<b>DELAY TIME (1)</b>								
Overcharge detection delay time	t <sub>CU</sub>	8	–	0.7	1.0	1.3	s	1
Overdischarge detection delay time	t <sub>DL</sub>	8	–	87.5	125	162.5	ms	1
Overcurrent 1 detection delay time	t <sub>OV1</sub>	9	–	5.6	8	10.4	ms	1
Overcurrent 2 detection delay time	t <sub>OV2</sub>	9	–	1.4	2	2.6	ms	1
Load short-circuiting detection delay time	t <sub>SHORT</sub>	9	–	–	10	50	μs	1
<b>DELAY TIME (2)</b>								
Overcharge detection delay time	t <sub>CU</sub>	8	–	87.5	125	162.5	ms	1
Overdischarge detection delay time	t <sub>DL</sub>	8	–	21	31	41	ms	1
Overcurrent 1 detection delay time	t <sub>OV1</sub>	9	–	11	16	21	ms	1
Overcurrent 2 detection delay time	t <sub>OV2</sub>	9	–	1.4	2	2.6	ms	1
Load short-circuiting detection delay time	t <sub>SHORT</sub>	9	–	–	10	50	μs	1
<b>DELAY TIME (3)</b>								
Overcharge detection delay time	t <sub>CU</sub>	8	–	0.175	0.25	0.325	s	1
Overdischarge detection delay time	t <sub>DL</sub>	8	–	87.5	125	162.5	ms	1
Overcurrent 1 detection delay time	t <sub>OV1</sub>	9	–	5.6	8	10.4	ms	1
Overcurrent 2 detection delay time	t <sub>OV2</sub>	9	–	1.4	2	2.6	ms	1
<b>DELAY TIME (4)</b>								
Overcharge detection delay time	t <sub>CU</sub>	8	–	1.4	2.0	2.6	s	1
Overdischarge detection delay time	t <sub>DL</sub>	8	–	87.5	125	162.5	ms	1
Overcurrent 1 detection delay time	t <sub>OV1</sub>	9	–	5.6	8	10.4	ms	1
Overcurrent 2 detection delay time	t <sub>OV2</sub>	9	–	1.4	2	2.6	ms	1
Load short-circuiting detection delay time	t <sub>SHORT</sub>	9	–	–	10	50	μs	1



# BATTERY PROTECTION IC FOR 1-CELL PACK S-8241 Series

Rev.4.1\_01

## ■ Electrical Characteristics (4) Detection delay time (-40 to 85°C\*1)

(Ta = -40 to 85°C \*1 unless otherwise specified)

Item	Symbol	Measurement conditions	Remarks	Min.	Typ.	Max.	Unit	Measurement circuit
<b>DELAY TIME (1)</b>								
Overcharge detection delay time	t <sub>CU</sub>	8	–	0.55	1.0	1.7	s	1
Overdischarge detection delay time	t <sub>DL</sub>	8	–	69	125	212	ms	1
Overcurrent 1 detection delay time	t <sub>I<sub>OV1</sub></sub>	9	–	4.4	8	14	ms	1
Overcurrent 2 detection delay time	t <sub>I<sub>OV2</sub></sub>	9	–	1.1	2	3.4	ms	1
Load short-circuiting detection delay time	t <sub>SHORT</sub>	9	–	–	10	73	μs	1
<b>DELAY TIME (2)</b>								
Overcharge detection delay time	t <sub>CU</sub>	8	–	69	125	212	ms	1
Overdischarge detection delay time	t <sub>DL</sub>	8	–	17	31	53	ms	1
Overcurrent 1 detection delay time	t <sub>I<sub>OV1</sub></sub>	9	–	9	16	27	ms	1
Overcurrent 2 detection delay time	t <sub>I<sub>OV2</sub></sub>	9	–	1.1	2	3.4	ms	1
Load short-circuiting detection delay time	t <sub>SHORT</sub>	9	–	–	10	73	μs	1
<b>DELAY TIME (3)</b>								
Overcharge detection delay time	t <sub>CU</sub>	8	–	0.138	0.25	0.425	s	1
Overdischarge detection delay time	t <sub>DL</sub>	8	–	69	125	212	ms	1
Overcurrent 1 detection delay time	t <sub>I<sub>OV1</sub></sub>	9	–	4.4	8	14	ms	1
Overcurrent 2 detection delay time	t <sub>I<sub>OV2</sub></sub>	9	–	1.1	2	3.4	ms	1
Load short-circuiting detection delay time	t <sub>SHORT</sub>	9	–	–	10	73	μs	1
<b>DELAY TIME (4)</b>								
Overcharge detection delay time	t <sub>CU</sub>	8	–	1.1	2.0	3.4	s	1
Overdischarge detection delay time	t <sub>DL</sub>	8	–	69	125	212	ms	1
Overcurrent 1 detection delay time	t <sub>I<sub>OV1</sub></sub>	9	–	4.4	8	14	ms	1
Overcurrent 2 detection delay time	t <sub>I<sub>OV2</sub></sub>	9	–	1.1	2	3.4	ms	1
Load short-circuiting detection delay time	t <sub>SHORT</sub>	9	–	–	10	73	μs	1

\*1. Since products are not screened at high and low temperatures, the specification for this temperature range is guaranteed by design, not tested in production.

## ■ Measurement Circuits

Unless otherwise specified, the output voltage levels "H" and "L" at CO and DO pins are judged by the threshold voltage (1.0 V) of a Nch FET. Judge the CO pin level with respect to  $V_{VM}$  and the DO pin level with respect to  $V_{SS}$ . Voltages V1 to V4 are shown in the figure 4.

### (1) Measurement Condition 1, Measurement Circuit 1

⟨⟨ Overcharge detection voltage, Overcharge release voltage, Overdischarge detection voltage, Overdischarge release voltage ⟩⟩

The overcharge detection voltage ( $V_{CU}$ ) is defined by the voltage between VDD and VSS at which  $V_{CO}$  goes "L" from "H" when the voltage V1 is gradually increased from the normal condition  $V1=3.5$  V and  $V2=0$  V. The overcharge release voltage ( $V_{CL}$ ) is defined by the voltage between VDD and VSS at which  $V_{CO}$  goes "H" from "L" when the voltage V1 is then gradually decreased.

Gradually decreasing the voltage V1, the overdischarge detection voltage ( $V_{DL}$ ) is defined by the voltage between VDD and VSS at which  $V_{DO}$  goes "L" from "H". The overdischarge release voltage ( $V_{DU}$ ) is defined by the voltage between VDD and VSS at which  $V_{DO}$  goes "H" from "L" when the voltage V1 is then gradually increased.

### (2) Measurement Condition 2, Measurement Circuit 1

⟨⟨ Overcurrent 1 detection voltage, Overcurrent 2 detection voltage, Load short-circuiting detection voltage ⟩⟩

The overcurrent 1 detection voltage ( $V_{IOV1}$ ) is defined by the voltage between VDD and VSS at which  $V_{DO}$  goes "L" from "H" when the voltage V2 is gradually increased from the normal condition  $V1=3.5$  V and  $V2=0$  V.

The overcurrent 2 detection voltage ( $V_{IOV2}$ ) is defined by the voltage between VDD and VSS at which  $V_{DO}$  goes "L" from "H" when the voltage V2 is increased at the speed between 1 ms and 4 ms from the normal condition  $V1=3.5$  V and  $V2=0$  V.

The load short-circuiting detection voltage ( $V_{SHORT}$ ) is defined by the voltage between VDD and VSS at which  $V_{DO}$  goes "L" from "H" when the voltage V2 is increased at the speed between 1  $\mu$ s and 50  $\mu$ s from the normal condition  $V1=3.5$  V and  $V2=0$  V.

### (3) Measurement Condition 3, Measurement Circuit 1

⟨⟨ Charger detection voltage, (=abnormal charge current detection voltage) ⟩⟩

- Applied only for products with overdischarge hysteresis  
Set  $V1=1.8$  V and  $V2=0$  V under overdischarge condition. Increase V1 gradually, set  $V1=(V_{DU}+V_{DL})/2$  (within overdischarge hysteresis, overdischarge condition), then decrease V2 from 0 V gradually. The voltage between VM and VSS at which  $V_{DO}$  goes "H" from "L" is the charger detection voltage ( $V_{CHA}$ ).
- Applied only for products without overdischarge hysteresis  
Set  $V1=3.5$  V and  $V2=0$  V under normal condition. Decrease V2 from 0 V gradually. The voltage between VM and VSS at which  $V_{CO}$  goes "L" from "H" is the abnormal charge current detection voltage. The abnormal charge current detection voltage has the same value as the charger detection voltage ( $V_{CHA}$ ).

## (4) Measurement Condition 4, Measurement Circuit 1

⟨⟨ Normal operation current consumption, Power-down current consumption, Overdischarge current consumption ⟩⟩

Set V1=3.5 V and V2=0 V under normal condition. The current  $I_{DD}$  flowing through VDD pin is the normal operation consumption current ( $I_{OPE}$ ).

- For products with power-down function

Set V1=V2=1.5 V under overdischarge condition. The current  $I_{DD}$  flowing through VDD pin is the power-down current consumption ( $I_{PDN}$ ).

- For products without power-down function

Set V1=V2=1.5 V under overdischarge condition. The current  $I_{DD}$  flowing through VDD pin is the overdischarge current consumption ( $I_{OPED}$ ).

## (5) Measurement Condition 5, Measurement Circuit 1

⟨⟨ Internal resistance between VM and VDD, Internal resistance between VM and VSS ⟩⟩

Set V1=1.8 V and V2=0 V under overdischarge condition. Measure current  $I_{VM}$  flowing through VM pin.  $1.8V/|I_{VM}|$  gives the internal resistance ( $R_{VMD}$ ) between VM and VDD.

Set V1=V2=3.5 V under overcurrent condition. Measure current  $I_{VM}$  flowing through VM pin.  $3.5V/|I_{VM}|$  gives the internal resistance ( $R_{VMS}$ ) between VM and VSS.

## (6) Measurement Condition 6, Measurement Circuit 1

⟨⟨ CO pin H resistance, CO pin L resistance ⟩⟩

Set V1=3.5 V, V2=0 V and V3=3.0 V under normal condition. Measure current  $I_{CO}$  flowing through CO pin.  $0.5V/|I_{CO}|$  is the CO pin H resistance ( $R_{COH}$ ).

Set V1=4.5 V, V2=0 V and V3=0.5 V under overcharge condition. Measure current  $I_{CO}$  flowing through CO pin.  $0.5V/|I_{CO}|$  is the CO pin L resistance ( $R_{COL}$ ).

## (7) Measurement Condition 7, Measurement Circuit 1

⟨⟨ DO pin H resistance, DO pin L resistance ⟩⟩

Set V1=3.5 V, V2=0 V and V4=3.0 V under normal condition. Measure current  $I_{DO}$  flowing through DO pin.  $0.5V/|I_{DO}|$  gives the DO pin H resistance ( $R_{DOH}$ ).

Set V1=1.8 V, V2=0 V and V4=0.5 V under overdischarge condition. Measure current  $I_{DO}$  flowing through DO pin.  $0.5V/|I_{DO}|$  gives the DO pin L resistance ( $R_{DOL}$ ).

## (8) Measurement Condition 8, Measurement Circuit 1

⟨⟨ Overcharge detection delay time, Overdischarge detection delay time ⟩⟩

Set V1=3.5 V and V2=0 V under normal condition. Increase V1 gradually to overcharge detection voltage  $V_{CU} - 0.2V$  and increase V1 to the overcharge detection voltage  $V_{CU} + 0.2V$  momentarily (within 10  $\mu$ s). The time after V1 becomes the overcharge detection voltage until  $V_{CO}$  goes "L" is the overcharge detection delay time ( $t_{CU}$ ).

Set V1=3.5 V and V2=0 V under normal condition. Decrease V1 gradually to overdischarge detection voltage  $V_{DL} + 0.2V$  and decrease V1 to the overdischarge detection voltage  $V_{DL} - 0.2V$  momentarily (within 10  $\mu$ s). The time after V1 becomes the overdischarge detection voltage  $V_{DL}$  until  $V_{DO}$  goes "L" is the overdischarge detection delay time ( $t_{DL}$ ).

(9) Measurement Condition 9, Measurement Circuit 1

⟨⟨ Overcurrent 1 detection delay time, Overcurrent 2 detection delay time, Load short-circuiting detection delay time, Abnormal charge current detection delay time ⟩⟩

Set  $V1=3.5V$  and  $V2=0V$  under normal condition. Increase  $V2$  from  $0V$  to  $0.35V$  momentarily (within  $10\mu s$ ). The time after  $V2$  becomes overcurrent 1 detection voltage ( $V_{IOV1}$ ) until  $V_{DO}$  goes "L" is overcurrent 1 detection delay time ( $t_{IOV1}$ ).

Set  $V1=3.5V$  and  $V2=0V$  under normal condition. Increase  $V2$  from  $0V$  to  $0.7V$  momentarily (within  $1\mu s$ ). The time after  $V2$  becomes overcurrent 1 detection voltage ( $V_{IOV1}$ ) until  $V_{DO}$  goes "L" is overcurrent 2 detection delay time ( $t_{IOV2}$ ).

Note: The overcurrent 2 detection delay time starts when the overcurrent 1 is detected, since the delay circuit is common.

Set  $V1=3.5V$  and  $V2=0V$  under normal condition. Increase  $V2$  from  $0V$  to  $3.0V$  momentarily (within  $1\mu s$ ). The time after  $V2$  becomes the load short-circuiting detection voltage ( $V_{SHORT}$ ) until  $V_{DO}$  goes "L" is the load short-circuiting detection delay time ( $t_{SHORT}$ ).

Set  $V1=3.5V$  and  $V2=0V$  under normal condition. Decrease  $V2$  from  $0V$  to  $-2.5V$  momentarily (within  $10\mu s$ ). The time after  $V2$  becomes the charger detection voltage ( $V_{CHA}$ ) until  $V_{CO}$  goes "L" is the abnormal charge current detection delay time. The abnormal charge current detection delay time has the same value as the overcharge detection delay time.

(10) Measurement Condition 10, Measurement Circuit 1 (Product with 0V battery charging function)

⟨⟨ 0V battery charge start charger voltage ⟩⟩

Set  $V1=V2=0V$  and decrease  $V2$  gradually. The voltage between  $VDD$  and  $VM$  at which  $V_{CO}$  goes "H" ( $V_{VM} + 0.1V$  or higher) is the 0V battery charge start charger voltage ( $V_{0CHA}$ ).

(11) Measurement Condition 11, Measurement Circuit 1 (Product with 0V battery charge inhibiting function)

⟨⟨ 0V battery charge inhibiting battery voltage ⟩⟩

Set  $V1=0V$  and  $V2=-4V$ . Increase  $V1$  gradually. The voltage between  $VDD$  and  $VSS$  at which  $V_{CO}$  goes "H" ( $V_{VM} + 0.1V$  or higher) is the 0V battery charge inhibiting battery voltage ( $V_{0INH}$ ).

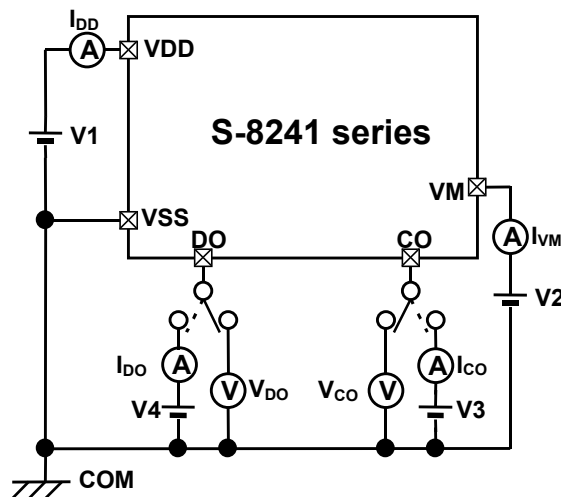

Measurement circuit 1

Figure 4

## ■ Operation

**Remark** Refer to the “■ Battery Protection IC Connection Example”.

### Normal Condition

The S-8241 monitors the voltage of the battery connected to VDD and VSS pins and the voltage difference between VM and VSS pins to control charging and discharging. When the battery voltage is in the range from the overdischarge detection voltage ( $V_{DL}$ ) to the overcharge detection voltage ( $V_{CU}$ ), and the VM pin voltage is in the range from the charger detection voltage ( $V_{CHA}$ ) to the overcurrent 1 detection voltage ( $V_{IOV1}$ ) (the current flowing through the battery is equal to or lower than a specified value), the IC turns both the charging and discharging control FETs on. This condition is called normal condition and in this condition charging and discharging can be carried out freely.

### Overcurrent Condition

When the discharging current becomes equal to or higher than a specified value (the VM pin voltage is equal to or higher than the overcurrent detection voltage) during discharging under normal condition and the state continues for the overcurrent detection delay time or longer, the S-8241 turns the discharging control FET off to stop discharging. This condition is called overcurrent condition. (The overcurrent includes overcurrent 1, overcurrent 2, or load short-circuiting.)

The VM and VSS pins are shorted internally by the  $R_{VMS}$  resistor under the overcurrent condition. When a load is connected, the VM pin voltage equals the  $V_{DD}$  voltage due to the load.

The overcurrent condition returns to the normal condition when the load is released and the impedance between the EB+ and EB- pins (see the figure 10 for a connection example) becomes higher than the automatic recoverable impedance (see the equation [1] below). When the load is removed, the VM pin goes back to the  $V_{SS}$  potential since the VM pin is shorted the VSS pin with the  $R_{VMS}$  resistor. Detecting that the VM pin potential is lower than the overcurrent 1 detection voltage ( $V_{IOV1}$ ), the IC returns to the normal condition.

Automatic recoverable impedance = {Battery voltage / (Minimum value of overcurrent 1 detection voltage) - 1} x ( $R_{VMS}$  maximum value) --- [1]

Example: Battery voltage = 3.5 V and overcurrent 1 detection voltage ( $V_{IOV1}$ ) = 0.1 V

Automatic recoverable impedance = (3.5 V / 0.07 V - 1) x 200 k $\Omega$  = 9.8 M $\Omega$

**Remark** The automatic recoverable impedance varies with the battery voltage and overcurrent 1 detection voltage settings. Determine the minimum value of the open load using the above equation [1] to have automatic recovery from the overcurrent condition work after checking the overcurrent 1 detection voltage setting for the IC.

### Overcharge Condition

When the battery voltage becomes higher than the overcharge detection voltage ( $V_{CU}$ ) during charging under normal condition and the state continues for the overcharge detection delay time ( $t_{CU}$ ) or longer, the S-8241 turns the charging control FET off to stop charging. This condition is called the overcharge condition. The overcharge condition is released in the following two cases (① and ②) depending on the products with and without overcharge hysteresis:

- ◆ Products with overcharge hysteresis (overcharge detection voltage ( $V_{CU}$ ) > overcharge release voltage ( $V_{CL}$ ))
  - ① When the battery voltage drops below the overcharge release voltage ( $V_{CL}$ ), the S-8241 turns the charging control FET on and returns to the normal condition.
  - ② When a load is connected and discharging starts, the S-8241 turns the charging control FET on and returns to the normal condition. The release mechanism is as follows: the discharging current flows through an internal parasitic diode of the charging FET immediately after a load is connected and discharging starts, and the VM pin voltage increases about 0.7 V ( $V_f$  voltage of the diode) from the VSS pin voltage momentarily. The IC detects this voltage (being higher than the overcurrent 1 detection voltage) and releases the overcharge condition. Consequently, in the case that the battery voltage is equal to or lower than the overcharge detection voltage ( $V_{CU}$ ), the IC returns to the normal condition immediately, but in the case the battery voltage is higher than the overcharge detection voltage ( $V_{CU}$ ), the IC does not return to the normal condition until the battery voltage drops below the overcharge detection voltage ( $V_{CU}$ ) even if the load is connected. In addition if the VM pin voltage is equal to or lower than the overcurrent 1 detection voltage when a load is connected and discharging starts, the IC does not return to the normal condition.

**Remark** If the battery is charged to a voltage higher than the overcharge detection voltage ( $V_{CU}$ ) and the battery voltage does not drop below the overcharge detection voltage ( $V_{CU}$ ) even when a heavy load, which causes an overcurrent, is connected, the overcurrent 1 and overcurrent 2 do not work until the battery voltage drops below the overcharge detection voltage ( $V_{CU}$ ). Since an actual battery has, however, an internal impedance of several dozens of  $m\Omega$ , and the battery voltage drops immediately after a heavy load which causes an overcurrent is connected, the overcurrent 1 and overcurrent 2 work. Detection of load short-circuiting works regardless of the battery voltage.

- ◆ Products without overcharge hysteresis (Overcharge detection voltage ( $V_{CU}$ ) = Overcharge release voltage ( $V_{CL}$ ))
  - ① When the battery voltage drops below the overcharge release voltage ( $V_{CL}$ ), the S-8241 turn the charging control FET on and returns to the normal condition.
  - ② When a load is connected and discharging starts, the S-8241 turns the charging control FET on and returns to the normal condition. The release mechanism is explained as follows : the discharging current flows through an internal parasitic diode of the charging FET immediately after a load is connected and discharging starts, and the VM pin voltage increases about 0.7 V ( $V_f$  voltage of the diode) from the VSS pin voltage momentarily. Detecting this voltage (being higher than the overcurrent 1 detection voltage), the IC increases the overcharge detection voltage about 50 mV, and releases the overcharge condition. Consequently, when the battery voltage is equal to or lower than the overcharge detection voltage ( $V_{CU}$ ) + 50 mV, the S-8241 immediately returns to the normal condition. But the battery voltage is higher than the overcharge detection voltage ( $V_{CU}$ ) + 50 mV, the S-8241 does not return to the normal condition until the battery voltage drops below the overcharge detection voltage ( $V_{CU}$ ) + 50 mV even if a load is connected. If the VM pin voltage is equal to or lower than the overcurrent 1 detection voltage when a load is connected and discharging starts, the S-8241 does not return to the normal condition.

**Remark** If the battery is charged to a voltage higher than the overcharge detection voltage ( $V_{CU}$ ) and the battery voltage does not drop below the overcharge detection voltage ( $V_{CU}$ ) + 50 mV even when a heavy load, which causes an overcurrent, is connected, the overcurrent 1 and overcurrent 2 do not work until the battery voltage drops below the overcharge detection voltage ( $V_{CU}$ ) + 50 mV. Since an actual battery has, however, an internal impedance of several dozens of  $m\Omega$ , and the battery voltage drops immediately after a heavy load which causes an overcurrent is connected, the overcurrent 1 and overcurrent 2 work. Detection of load short-circuiting works regardless of the battery voltage.

### Overdischarge Condition (for products with power-down function)

When the battery voltage drops below the overdischarge detection voltage ( $V_{DL}$ ) during discharging under normal condition and it continues for the overdischarge detection delay time ( $t_{DL}$ ) or longer, the S-8241 turns the discharging control FET off and stops discharging. This condition is called overdischarge condition. After the discharging control FET is turned off, the VM pin is pulled up by the  $R_{VMD}$  resistor between VM and VDD in the IC. Meanwhile the potential difference between VM and VDD drops below 1.3 V (typ.) (the load short-circuiting detection voltage), current consumption of the IC is reduced to the power-down current consumption ( $I_{PDN}$ ). This condition is called power-down condition. The VM and VDD pins are shorted by the  $R_{VMD}$  resistor in the IC under the overdischarge and power-down conditions. The power-down condition is released when a charger is connected and the potential difference between VM and VDD becomes 1.3 V (typ.) or higher (load short-circuiting detection voltage). At this time, the FET is still off. When the battery voltage becomes the overdischarge detection voltage ( $V_{DL}$ ) or higher (see note), the S-8241 turns the FET on and changes to the normal condition from the overdischarge condition.

**Remark** If the VM pin voltage is no less than the charger detection voltage ( $V_{CHA}$ ), when the battery under overdischarge condition is connected to a charger, the overdischarge condition is released (the discharging control FET is turned on) as usual, provided that the battery voltage reaches the overdischarge release voltage ( $V_{DU}$ ) or higher.

### Overdischarge Condition (for products without power-down function)

When the battery voltage drops below the overdischarge detection voltage ( $V_{DL}$ ) during discharging under normal condition and it continues for the overdischarge detection delay time ( $t_{DL}$ ) or longer, the S-8241 turns the discharging control FET off and stops discharging. When the discharging control FET is turned off, the VM pin is pulled up by the  $R_{VMD}$  resistor between VM and VDD in the IC. Meanwhile the potential difference between VM and VDD drops below 1.3 V (typ.) (the load short-circuiting detection voltage), current consumption of the IC is reduced to the overdischarge current consumption ( $I_{OPED}$ ). This condition is called overdischarge condition. The VM and VDD pins are shorted by the  $R_{VMD}$  resistor in the IC under the overdischarge condition.

When a charger is connected, the overdischarge condition is released in the same way as explained above in respect to products having the power-down function. For products without the power-down function, in addition, even if the charger is not connected, the S-8241 turns the discharging control FET on and changes to the normal condition from the overdischarge condition provided that the load is disconnected and that the potential difference between VM and VSS drops below the overcurrent 1 detection voltage ( $V_{IOV1}$ ), since the VM pin is pulled down by the  $R_{VMS}$  resistor between VM and VSS in the IC when the battery voltage reaches the overdischarge release voltage ( $V_{DU}$ ) or higher.

### Charger Detection

If the VM pin voltage is lower than the charger detection voltage ( $V_{CHA}$ ) when a battery in overdischarge condition is connected to a charger, overdischarge hysteresis is released, and when the battery voltage becomes equal to or higher than the overdischarge detection voltage ( $V_{DL}$ ), the overdischarge condition is released (the discharging control FET is turned on). This action is called charger detection. (The charger detection reduces the time for charging in which charging current flows through the internal parasitic diode in the discharging control FET.)

If the VM pin voltage is not lower than the charger detection voltage ( $V_{CHA}$ ) when a battery in overdischarge condition is connected to a charger, the overdischarge condition is released (the discharging control FET is turned on) as usual, when the battery voltage reaches the overdischarge release voltage ( $V_{DU}$ ) or higher.

**Abnormal Charge Current Detection**

If the VM pin voltage drops below the charger detection voltage ( $V_{CHA}$ ) during charging under the normal condition and it continues for the overcharge detection delay time ( $t_{CU}$ ) or longer, the S-8241 turns the charging control FET off and stops charging. This action is called abnormal charge current detection. Abnormal charge current detection works when the discharging control FET is on (DO pin voltage is "H") and the VM pin voltage drops below the charger detection voltage ( $V_{CHA}$ ). When an abnormal charge current flows into a battery in the overdischarge condition, the S-8241 consequently turns the charging control FET off and stops charging after the battery voltage becomes the overdischarge detection voltage or higher (DO pin voltage becomes "H") and the overcharge detection delay time ( $t_{CU}$ ) elapses. Abnormal charge current detection is released when the voltage difference between VM pin and VSS pin becomes lower than the charger detection voltage ( $V_{CHA}$ ) by separating the charger. Since the 0 V battery charging function has higher priority than the abnormal charge current detection function, abnormal charge current may not be detected by the product with the 0 V battery charging function while the battery voltage is low.

**Delay Circuits**

The following detection delay times are generated by dividing the approximate 2 kHz clock with a counter.  
 [Example] Overcharge detection delay time (= abnormal charge current detection delay time): 1.0s  
 Overdischarge detection delay time: 125 ms  
 Overcurrent 1 detection delay time: 8 ms  
 Overcurrent 2 detection delay time: 2 ms

**Caution 1.** After having detected an overcurrent (overcurrent 1, overcurrent 2, short-circuiting), the state is held for the overdischarge detection delay time or longer without releasing the load, the condition changes to the power-down condition when the battery voltage drops below the overdischarge detection voltage. If the battery voltage drops below the overdischarge detection voltage due to overcurrent, the discharging control FET is turned off when the overdischarge is detected. If the battery voltage recovers slowly and if the battery voltage after the overdischarge detection delay time is equal to or lower than the overdischarge detection voltage, the S-8241 changes to the power-down condition.

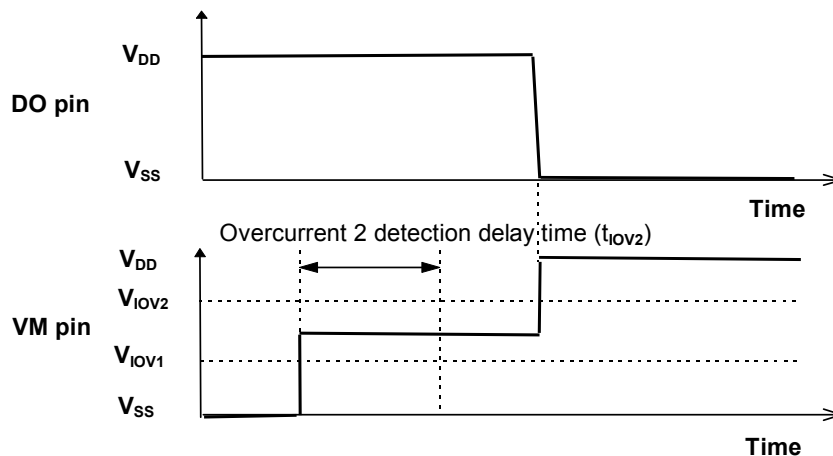

**Figure 5**

2. Counting for the overcurrent 2 detection delay time starts when the overcurrent 1 is detected. Having detected the overcurrent 1, if the overcurrent 2 is detected after the overcurrent 2 detection delay time, the S-8241 turns the discharging control FET off as shown in the figure 5. In this case, the overcurrent 2 detection delay time may seem to be longer or overcurrent 1 detection delay time may seem to be shorter than expected.



**0V Battery Charging Function** <sup>(1) (2) (3)</sup>

This function enables the charging of a connected battery whose voltage is 0 V by self-discharge. When a charger having 0 V battery start charging charger voltage ( $V_{0CHA}$ ) or higher is connected between EB+ and EB- pins, the charging control FET gate is fixed to  $V_{DD}$  potential. When the voltage between the gate and the source of the charging control FET becomes equal to or higher than the turn-on voltage by the charger voltage, the charging control FET is turned on to start charging. At this time, the discharging control FET is off and the charging current flows through the internal parasitic diode in the discharging control FET. If the battery voltage becomes equal to or higher than the overdischarge release voltage ( $V_{DU}$ ), the normal condition returns.

**0V Battery Charge Inhibiting Function** <sup>(1) (3)</sup>

This function forbids the charging of a connected battery which is short-circuited internally (0V battery). When the battery voltage becomes 0.9 V (typ.) or lower, the charging control FET gate is fixed to EB- potential to forbid charging. Charging can be performed, when the battery voltage is the 0 V battery charge inhibiting voltage ( $V_{0INH}$ ) or higher.

- (1) Some battery providers do not recommend charging of completely discharged batteries. Please refer to battery providers before the selection of 0 V battery charging function.
- (2) The 0V battery charging function has higher priority than the abnormal charge current detection function. Consequently, a product with the 0 V battery charging function charges a battery and abnormal charge current cannot be detected during the battery voltage is low (at most 1.8 V or lower).
- (3) When a battery is connected to the IC for the first time, the IC may not enter the normal condition in which discharging is possible. In this case, set the VM pin voltage equal to the  $V_{SS}$  voltage (short the VM and VSS pins or connect a charger) to enter the normal condition.

■ **Timing Chart**

1-1. Overcharge and overdischarge detection (for products with power-down function)

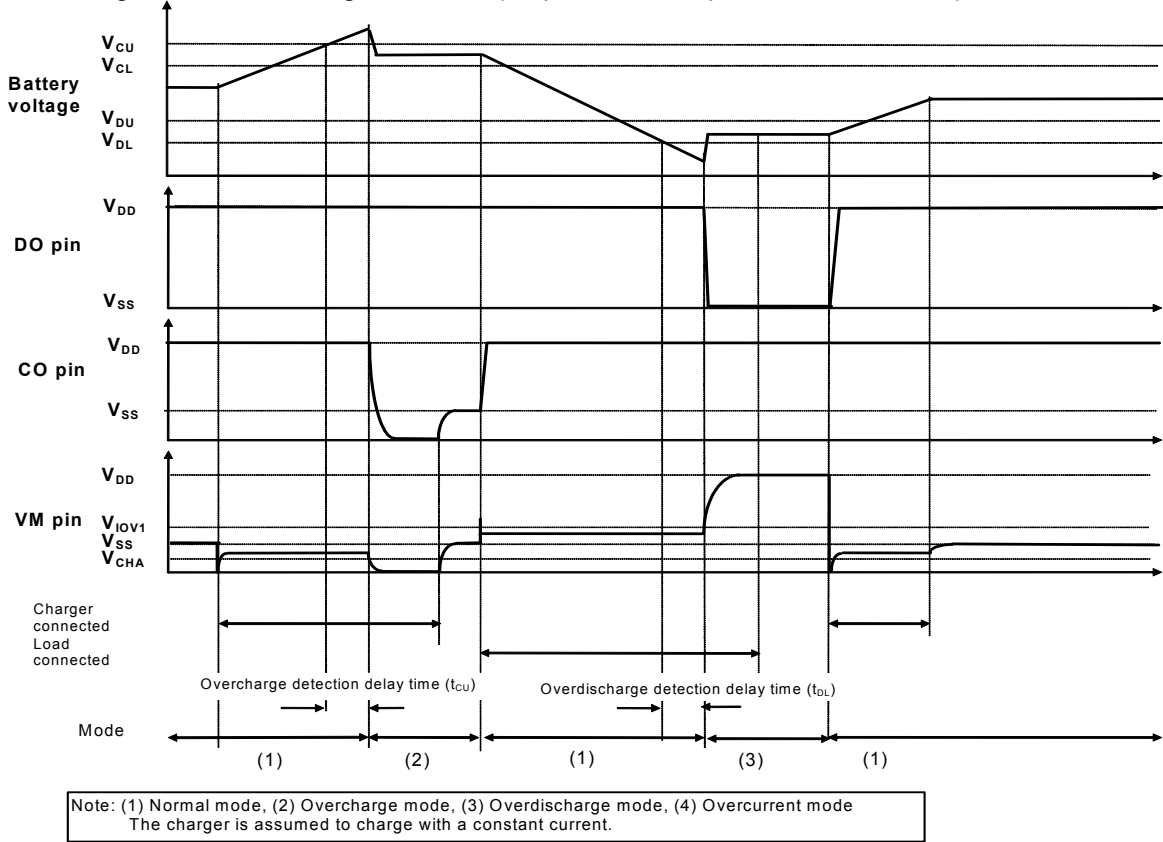

**Figure 6**

1-2. Overcharge and overdischarge detection (for products without power-down function)

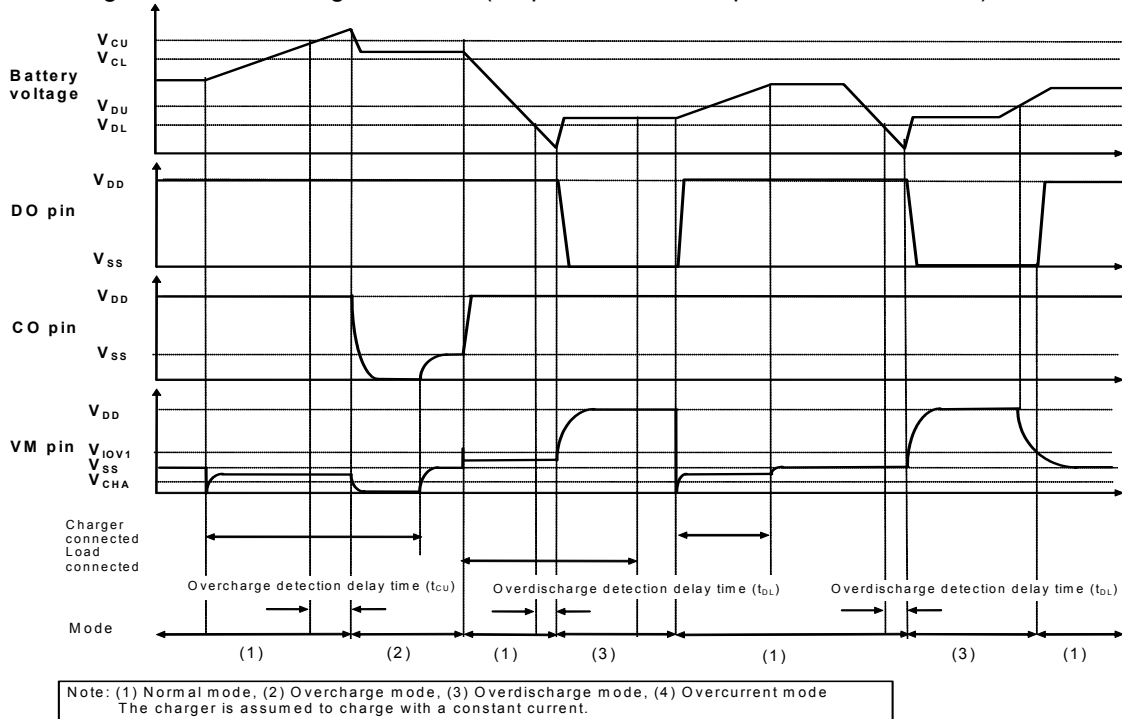

**Figure 7**

2. Overcurrent detection

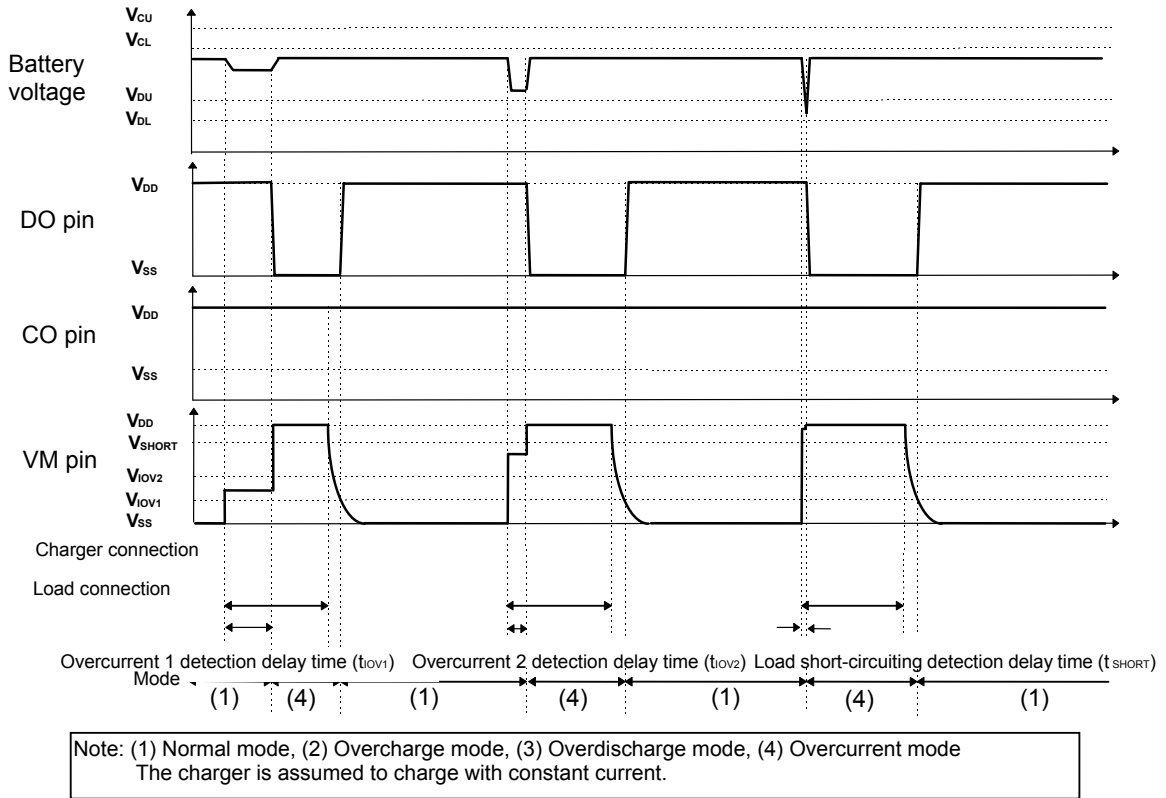

Figure 8

3. Charger detection

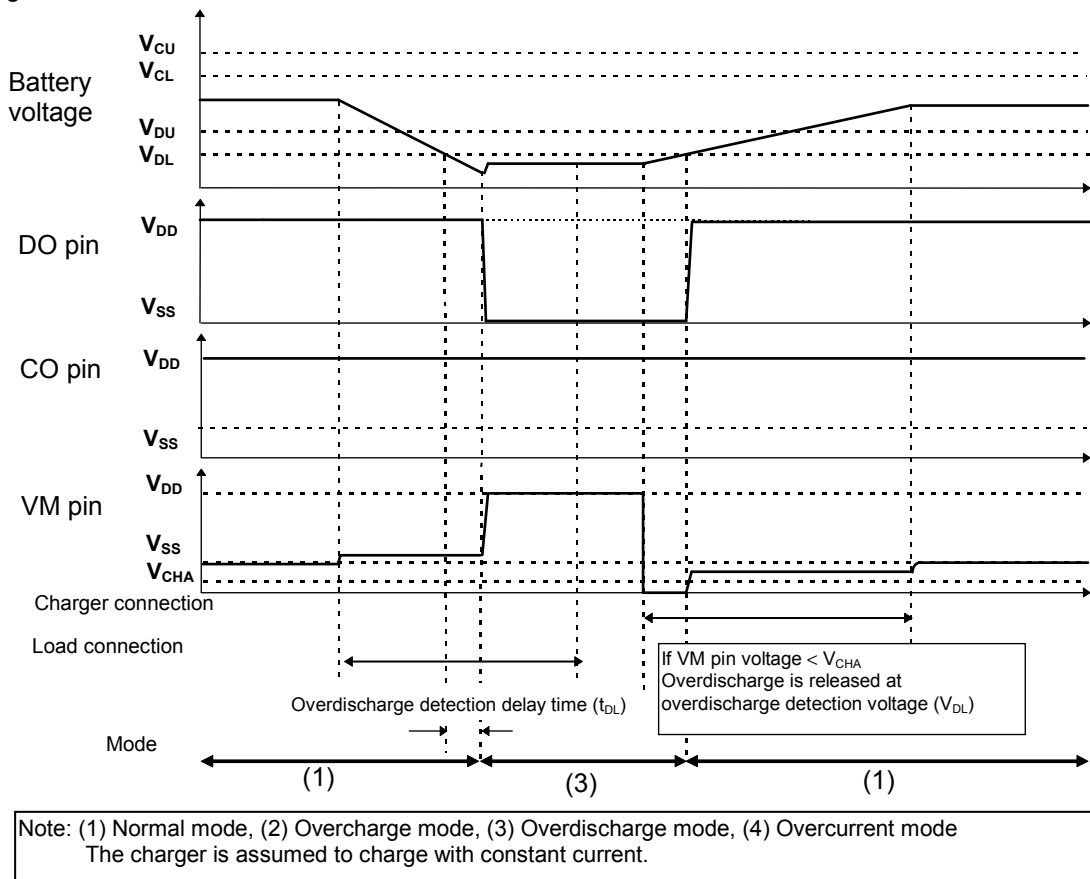
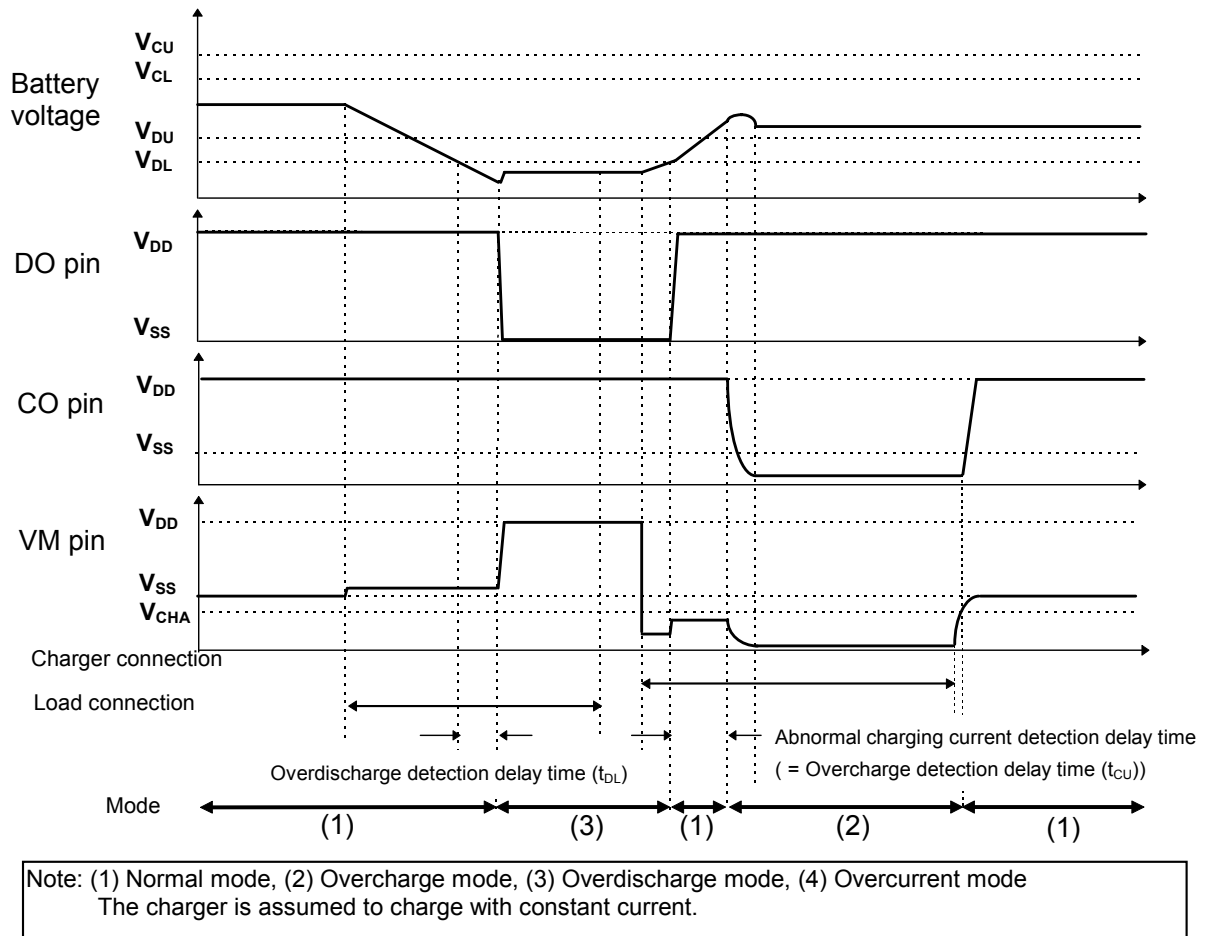

Figure 9

4. Abnormal charge current detection



**Figure 10**

■ **Battery Protection IC Connection Example**

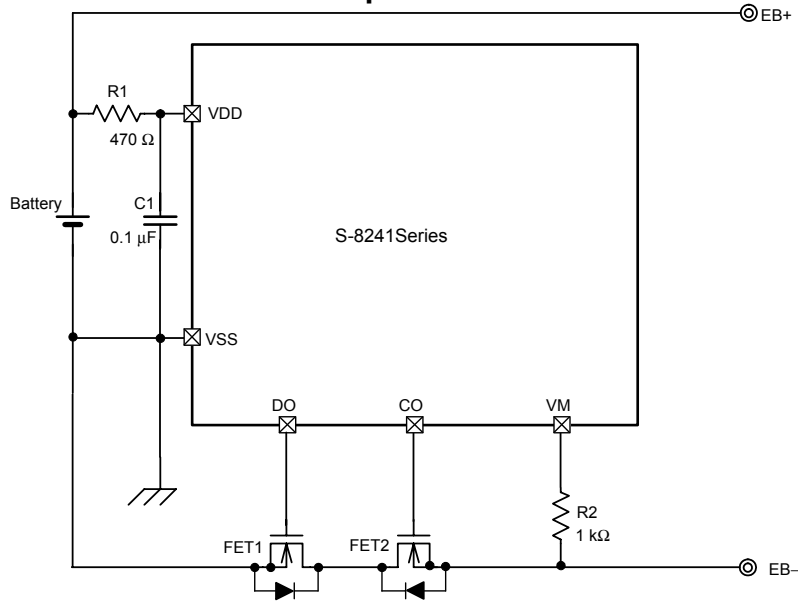

**Figure 11**

**Table 1 Constants for External Components**

Symbol	Parts	Purpose	Typ.	min.	max.	Remarks
FET1	Nch MOS_FET	Discharge control	—	—	—	0.4 V ≤ Threshold voltage ≤ overdischarge detection voltage. <sup>*1</sup> Withstand voltage between gate and source ≥ Charger voltage <sup>*2</sup>
FET2	Nch MOS_FET	Charge control	—	—	—	0.4 V ≤ Threshold voltage ≤ overdischarge detection voltage. <sup>*1</sup> Withstand voltage between gate and source ≥ Charger voltage <sup>*2</sup>
R1	Resistor	Protection for ESD and power fluctuation	470 Ω	300 Ω	R2 value	Relation R1 ≤ R2 should be maintained. <sup>*3</sup>
C1	Capacitor	Protection for power fluctuation	0.1 μF	0.01 μF	1.0 μF	Install a capacitor of 0.01 μF or higher between VDD and VSS. <sup>*4</sup>
R2	Resistor	Protection for charger reverse connection	1 kΩ	300 Ω	1.3 kΩ	To suppress current flow caused by reverse connection of a charger, set the resistance within the range from 300 Ω to 1.3 kΩ. <sup>*5</sup>

- \*1. If an FET with a threshold voltage of 0.4 V or lower is used, the FET may fail to cut the charging current.  
If an FET with a threshold voltage equal to or higher than the overdischarge detection voltage is used, discharging may stop before overdischarge is detected.
- \*2. If the withstand voltage between the gate and source is lower than the charger voltage, the FET may break.
- \*3. If R1 has a higher resistance than R2 and if a charger is connected reversely, current flows from the charger to the IC and the voltage between VDD and VSS may exceed the absolute maximum rating. Install a resistor of 300 Ω or higher as R1 for ESD protection.  
If R1 has a high resistance, the overcharge detection voltage increases by IC current consumption.
- \*4. If a capacitor C1 is less than 0.01 μF, DO may oscillate when load short-circuiting is detected, a charger is connected reversely, or overcurrent 1 or 2 is detected.  
A capacitor of 0.01 μF or higher as C1 should be installed. In some types of batteries DO oscillation may not stop unless the C1 capacity is increased. Set the C1 capacity by evaluating the actual application.
- \*5. If R2 is set to less than 300 Ω, a current which is bigger than the power dissipation flows through the IC and the IC may break when a charger is connected reversely. If a resistor bigger than 1.3 kΩ is installed as R2, the charging current may not be cut when a high-voltage charger is connected.

**Caution 1. The above constants may be changed without notice.**

**2. It has not been confirmed whether the operation is normal or not in circuits other than the above example of connection. In addition, the example of connection shown above and the constant do not guarantee proper operation. Perform through evaluation using the actual application to set the constant.**

■ **Precautions**

- Pay attention to the operating conditions for input/output voltage and load current so that the power loss in the IC does not exceed the power dissipation of the package.
- Do not apply an electrostatic discharge to this IC that exceeds the performance ratings of the built-in electrostatic protection circuit.
- SII claims no responsibility for any and all disputes arising out of or in connection with any infringement by products including this IC of patents owned by a third party.

■ Typical Characteristics

1. Detection/release voltage temperature characteristics

Overcharge detection voltage vs. temperature

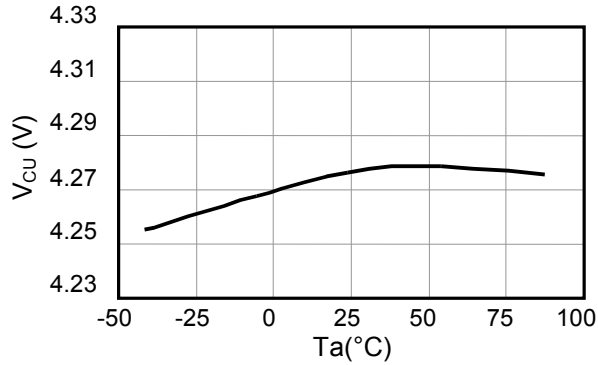

Overcharge release voltage vs. temperature

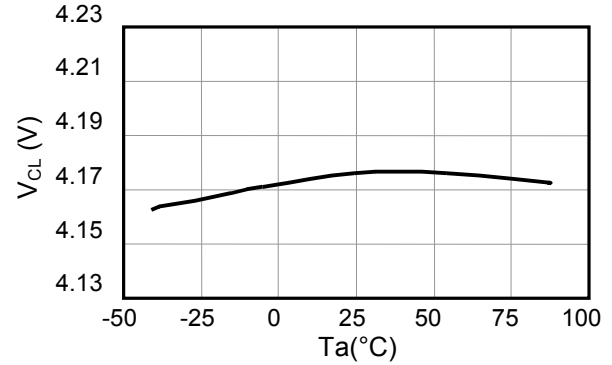

Overdischarge detection voltage vs. temperature

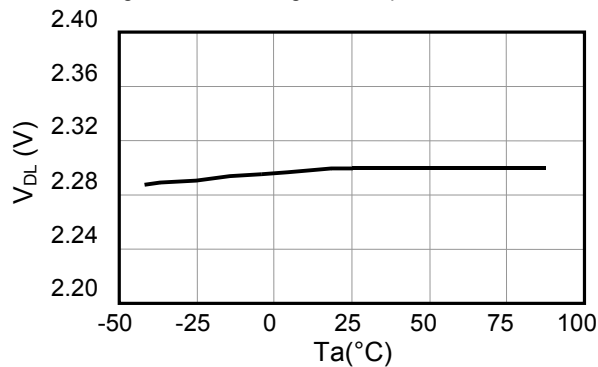

Overdischarge release voltage vs. temperature

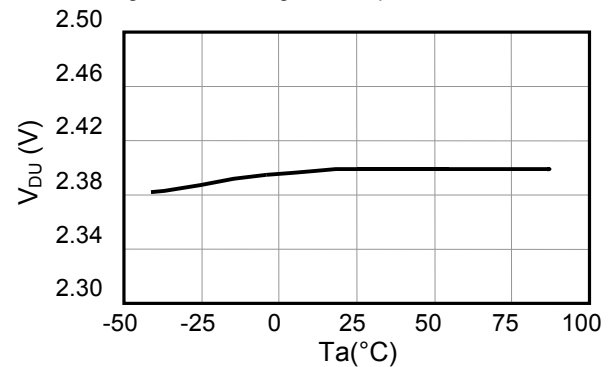

Overcurrent 1 detection voltage vs. temperature

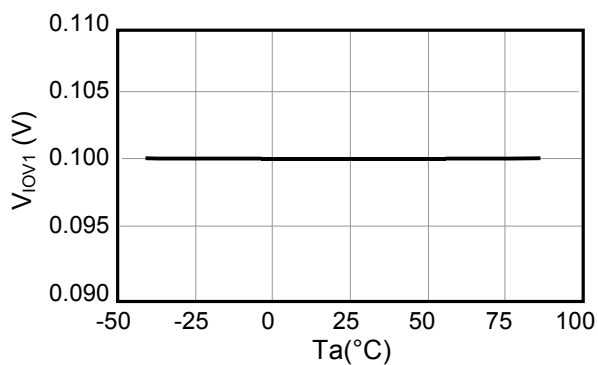

Overcurrent 2 detection voltage vs. temperature

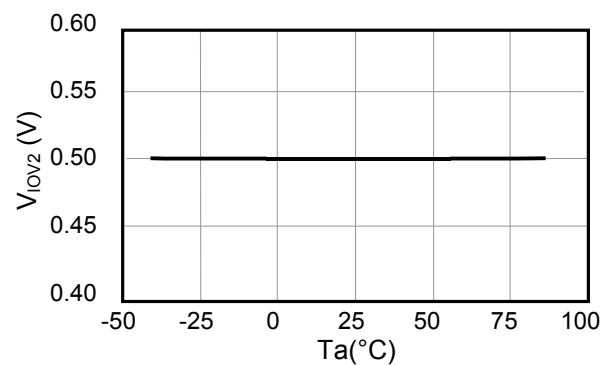

2. Current consumption temperature characteristics

Current consumption vs. Temperature in normal mode

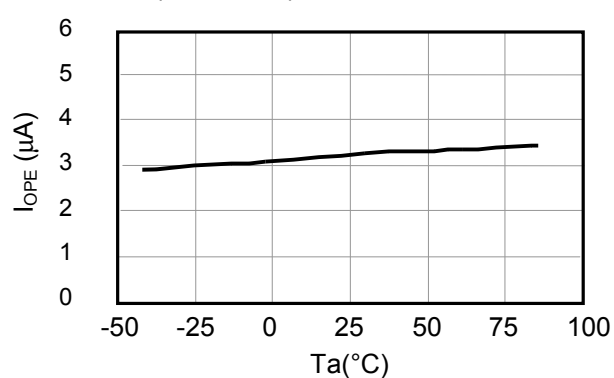

Current consumption vs. Temperature in power-down mode

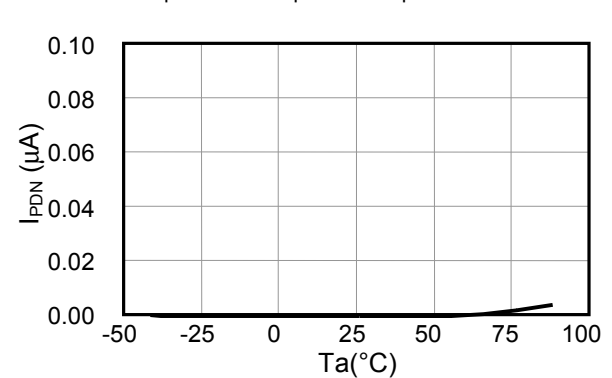

3. Current consumption Power voltage characteristics (Ta=25°C)

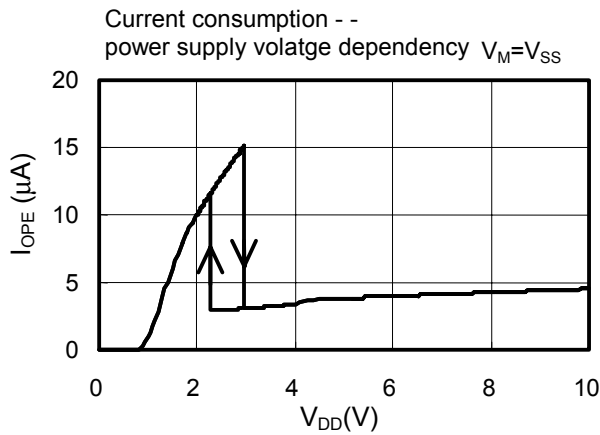

4. Detection/release delay time temperature characteristics

Overcharge detection delay time vs. temperature

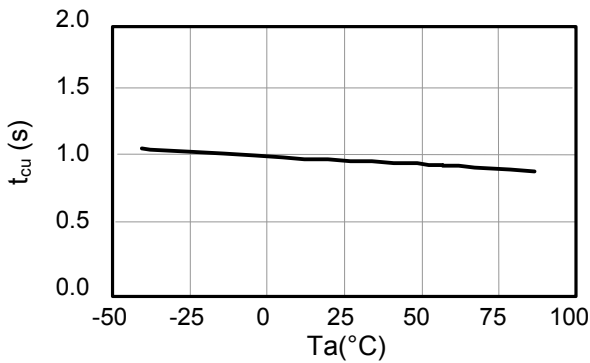

Overcharge release delay time vs. temperature

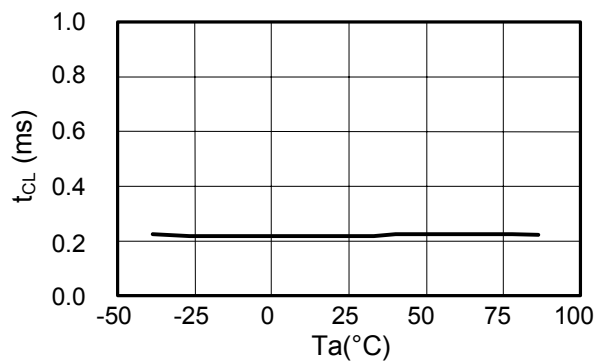

Overdischarge detection delay time vs. temperature

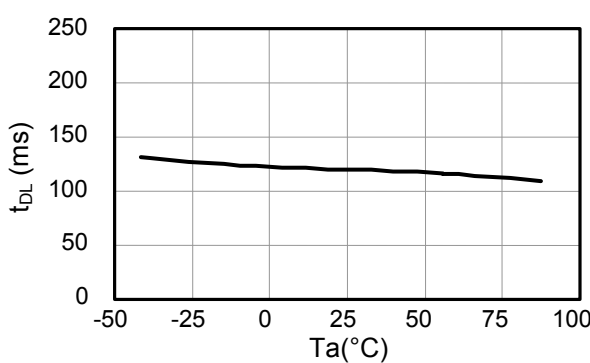

Overdischarge release delay time vs. temperature

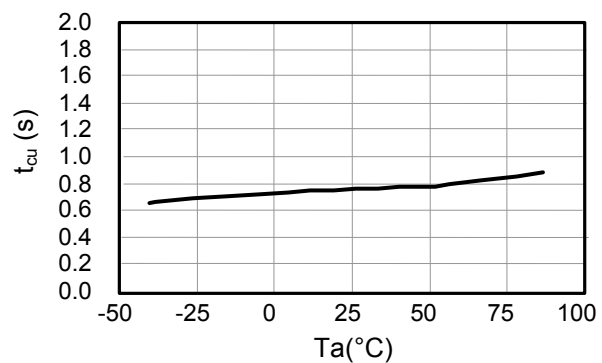

Overcurrent 1 detection delay time vs. temperature

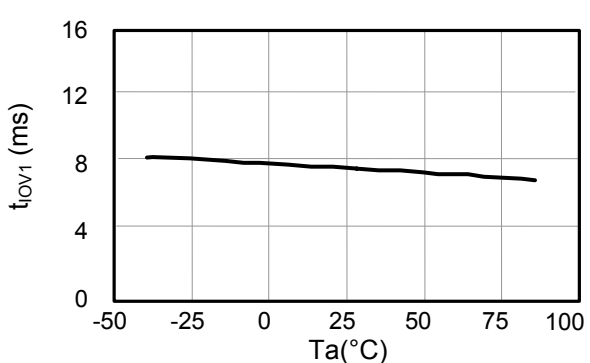

Overcurrent 1 release delay time vs. temperature

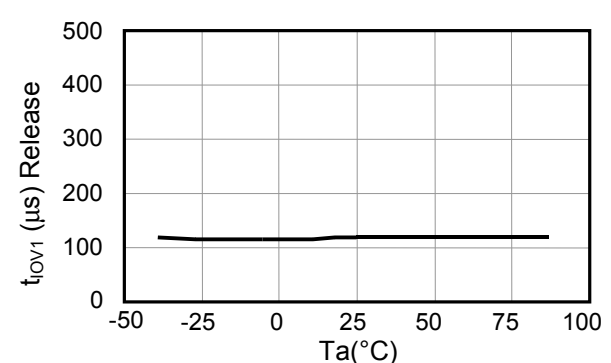



Overcurrent 2 detection delay time vs. temperature

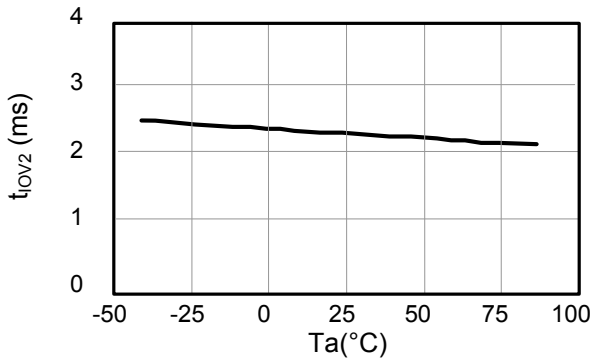

Load short-circuiting delay time vs. temperature

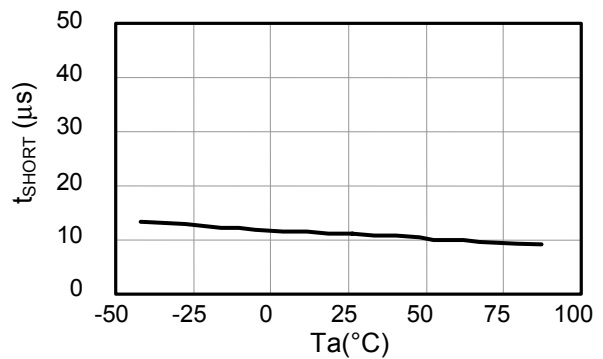

5. Delay time power-voltage characteristics(Ta=25°C)

Overcurrent 1 detection delay time vs. power supply voltage dependency

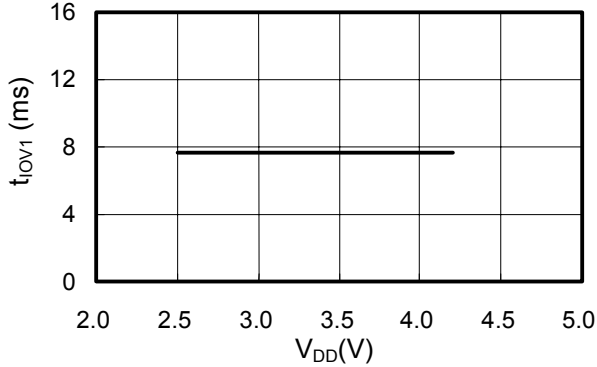

Overcurrent 2 detection delay time vs. power supply voltage dependency

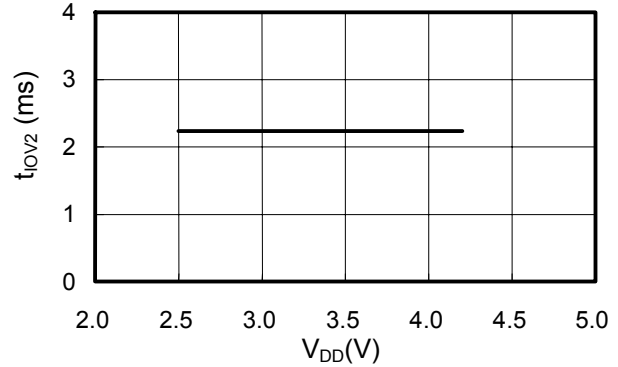

6. CO pin/DO pin output current characteristics(Ta=25°C)

CO pin source current characteristics  
V<sub>DD</sub>=3.5V, V<sub>SS</sub>=V<sub>M</sub>=0V

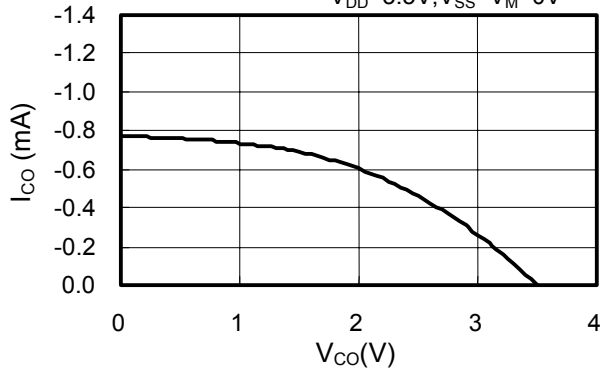

CO pin sink current characteristics  
V<sub>DD</sub>=4.5V, V<sub>SS</sub>=V<sub>M</sub>=0V

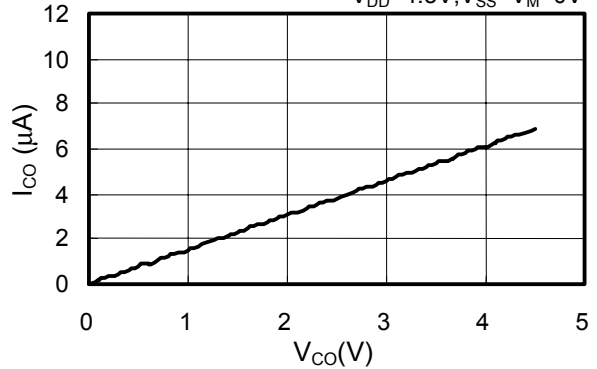

DO pin source current characteristics  
V<sub>DD</sub>=3.5V, V<sub>SS</sub>=V<sub>M</sub>=0V

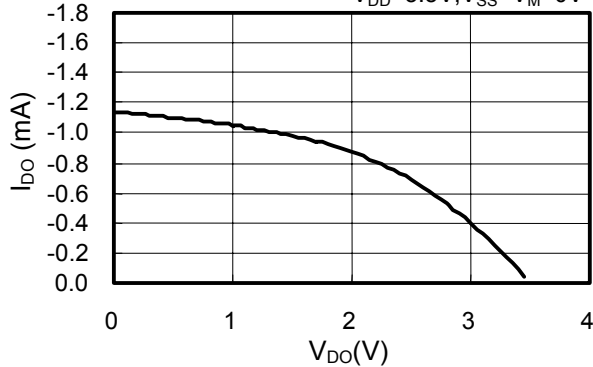

DO pin sink current characteristics  
V<sub>DD</sub>=1.8V, V<sub>SS</sub>=V<sub>M</sub>=0V

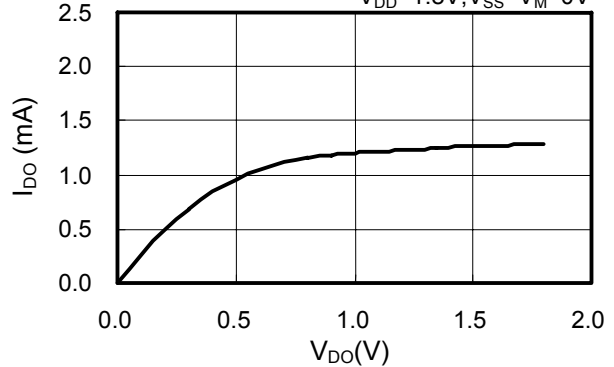

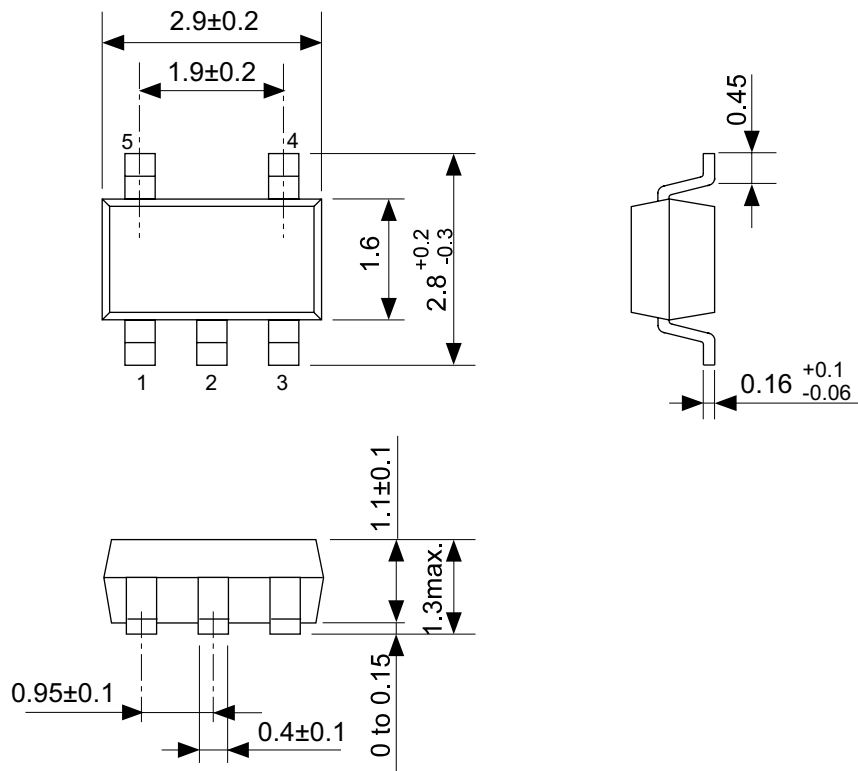

No. MP005-A-P-SD-1.2

TITLE	SOT235-A-PKG Dimensions
No.	MP005-A-P-SD-1.2
SCALE	
UNIT	mm
Seiko Instruments Inc.	

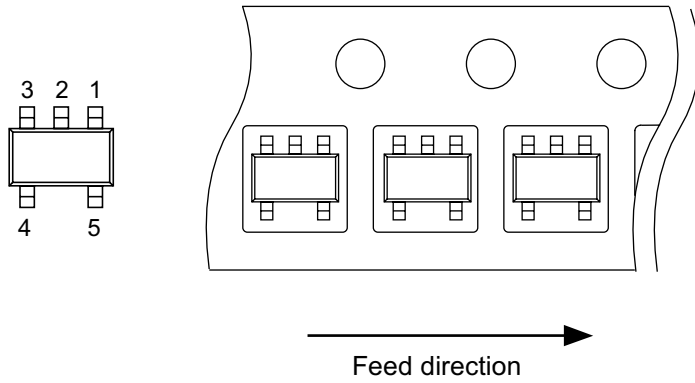
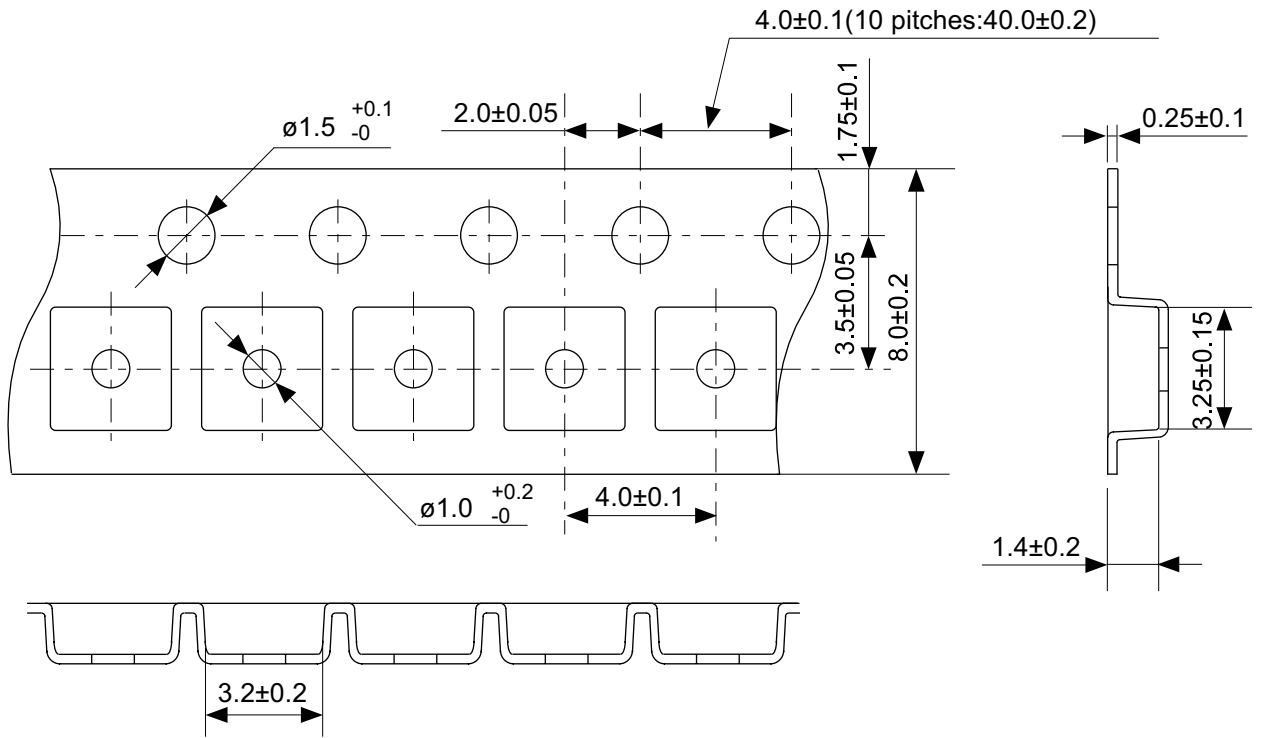

No. MP005-A-C-SD-2.1

TITLE	SOT235-A-Carrier Tape
No.	MP005-A-C-SD-2.1
SCALE	
UNIT	mm
Seiko Instruments Inc.	

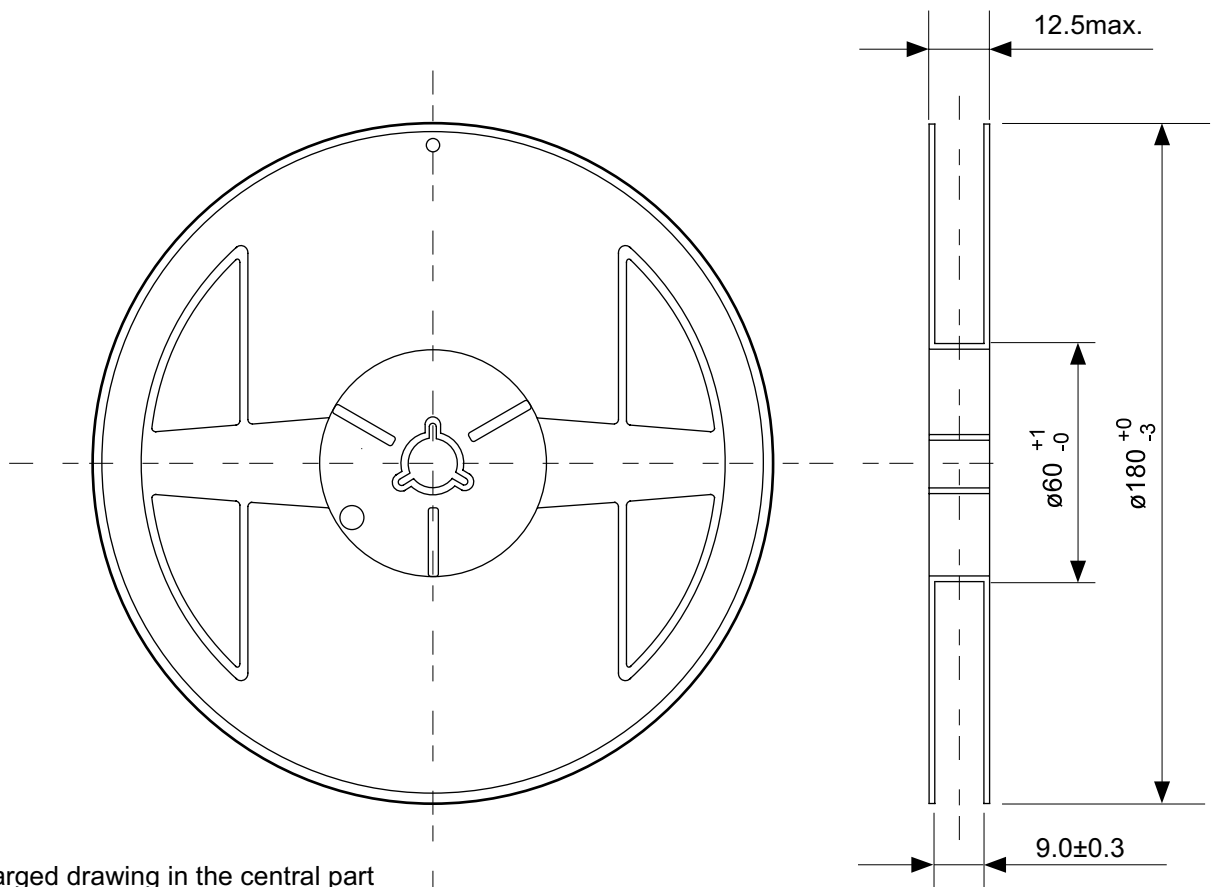

Enlarged drawing in the central part

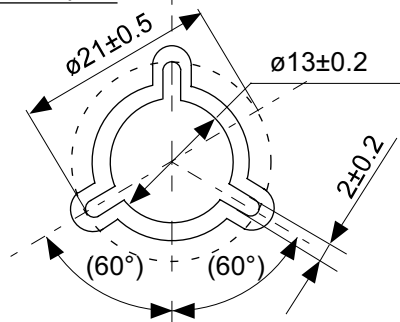

No. MP005-A-R-SD-1.1

TITLE	SOT235-A-Reel		
No.	MP005-A-R-SD-1.1		
SCALE		QTY.	3,000
UNIT	mm		
Seiko Instruments Inc.			

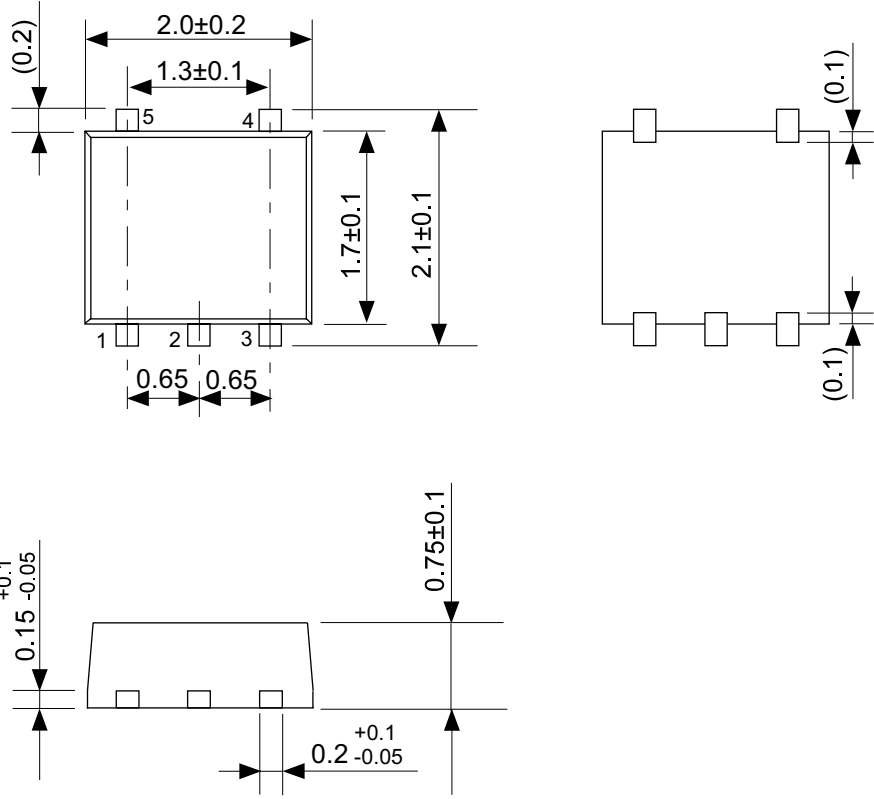

No. PN005-A-P-SD-1.1

TITLE	SON5A-A-PKG Dimensions
No.	PN005-A-P-SD-1.1
SCALE	
UNIT	mm
Seiko Instruments Inc.	

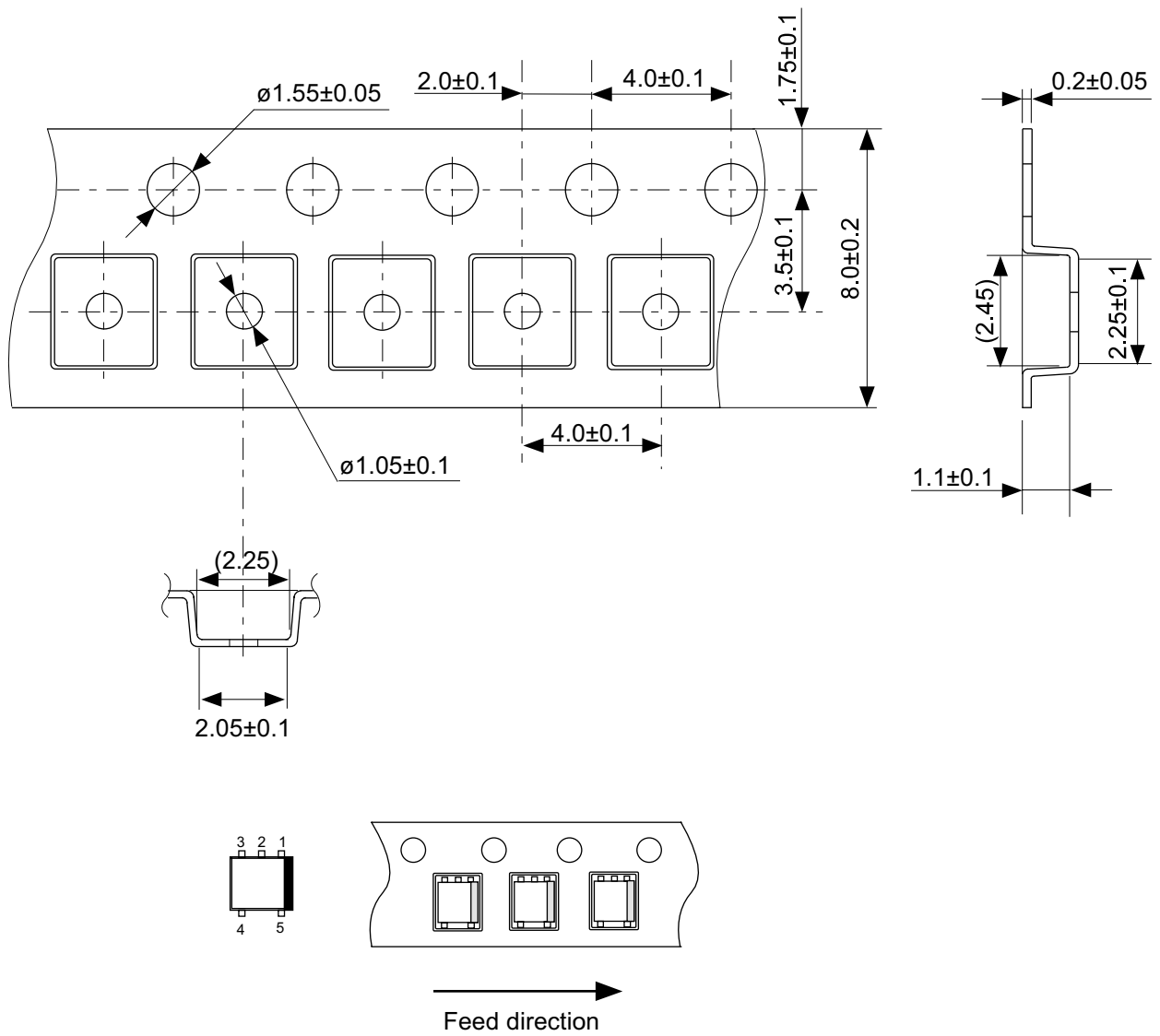

No. PN005-A-C-SD-1.1

TITLE	SON5A-A-Carrier Tape
No.	PN005-A-C-SD-1.1
SCALE	
UNIT	mm
Seiko Instruments Inc.	

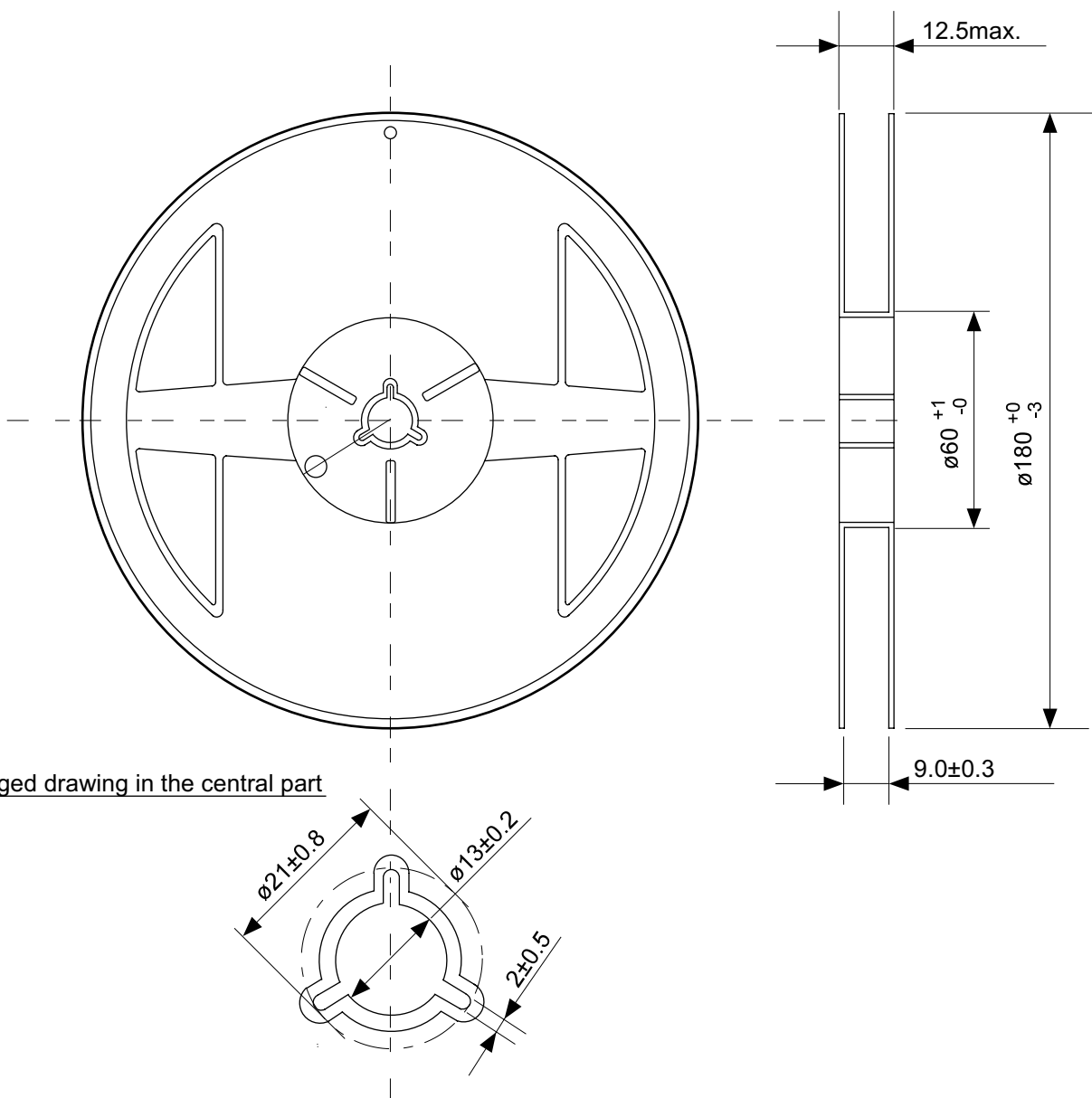

Enlarged drawing in the central part

No. PN005-A-R-SD-1.1

TITLE	SON5A-A-Reel		
No.	PN005-A-R-SD-1.1		
SCALE		QTY.	3000
UNIT	mm		
Seiko Instruments Inc.			

- The information described herein is subject to change without notice.
- Seiko Instruments Inc. is not responsible for any problems caused by circuits or diagrams described herein whose related industrial properties, patents, or other rights belong to third parties. The application circuit examples explain typical applications of the products, and do not guarantee the success of any specific mass-production design.
- When the products described herein are regulated products subject to the Wassenaar Arrangement or other agreements, they may not be exported without authorization from the appropriate governmental authority.
- Use of the information described herein for other purposes and/or reproduction or copying without the express permission of Seiko Instruments Inc. is strictly prohibited.
- The products described herein cannot be used as part of any device or equipment affecting the human body, such as exercise equipment, medical equipment, security systems, gas equipment, or any apparatus installed in airplanes and other vehicles, without prior written permission of Seiko Instruments Inc.
- Although Seiko Instruments Inc. exerts the greatest possible effort to ensure high quality and reliability, the failure or malfunction of semiconductor products may occur. The user of these products should therefore give thorough consideration to safety design, including redundancy, fire-prevention measures, and malfunction prevention, to prevent any accidents, fires, or community damage that may ensue.