

M54585P/FP

8-UNIT 500mA DARLINGTON TRANSISTOR ARRAY WITH CLAMP DIODE

DESCRIPTION

M54585P and M54585FP are eight-circuit Darlington transistor arrays with clamping diodes. The circuits are made of NPN transistors. Both the semiconductor integrated circuits perform high-current driving with extremely low input-current supply.

FEATURES

- High breakdown voltage ($BV_{CEO} \geq 50V$)
- High-current driving ($I_{c(max)} = 500mA$)
- With clamping diodes
- Driving available with TTL output or with PMOS IC output
- Wide operating temperature range ($T_a = -20$ to $+75^\circ C$)

APPLICATION

Drives of relays and printers, digit drives of indication elements such as LEDs and lamps, and MOS-bipolar logic IC interfaces

FUNCTION

The M54585P and M54585FP each have eight circuits, which are NPN Darlington transistors. Input transistors have resistance of $2.7k\Omega$ between the base and input pin. A spike-killer clamping diode is provided between each output pin and GND. Output transistor emitters are all connected to the GND pin.

Collector current is 500mA maximum. The maximum collector-emitter voltage is 50V.

The M54585FP is enclosed in a molded small flat package, enabling space-saving design.

PIN CONFIGURATION

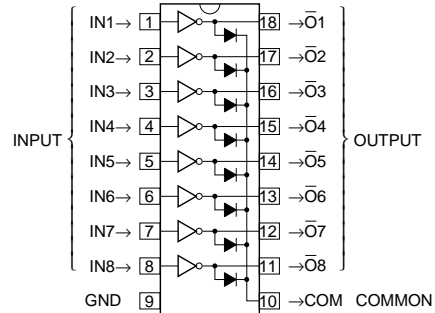

Package type 18P4G(P)

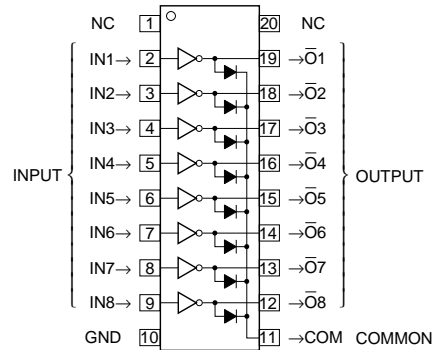

Package type 20P2N-A(FP)

NC : No connection

CIRCUIT DIAGRAM

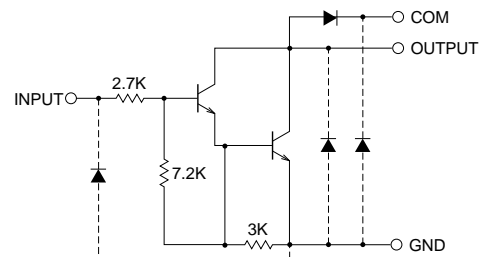

The eight circuits share the COM and GND.

The diode, indicated with the dotted line, is parasitic, and cannot be used.

Unit : Ω

8-UNIT 500mA DARLINGTON TRANSISTOR ARRAY WITH CLAMP DIODE

ABSOLUTE MAXIMUM RATINGS (Unless otherwise noted, Ta = -20 ~ +75°C)

Symbol	Parameter	Conditions	Ratings	Unit
V _{CEO}	Collector-emitter voltage	Output, H	-0.5 ~ +50	V
I _C	Collector current	Current per circuit output, L	500	mA
V _I	Input voltage		-0.5 ~ +30	V
I _F	Clamping diode forward current		500	mA
V _R	Clamping diode reverse voltage		50	V
P _d	Power dissipation	Ta = 25°C, when mounted on board	1.79(P)/1.10(FP)	W
T _{opr}	Operating temperature		-20 ~ +75	°C
T _{stg}	Storage temperature		-55 ~ +125	°C

RECOMMENDED OPERATING CONDITIONS (Unless otherwise noted, Ta = -20 ~ +75°C)

Symbol	Parameter	Limits			Unit	
		min	typ	max		
V _O	Output voltage	0	—	50	V	
I _C	Collector current (Current per 1 circuit when 8 circuits are coming on simultaneously)	Duty Cycle P : no more than 6% FP : no more than 4%	0	—	400	mA
		Duty Cycle P : no more than 34% FP : no more than 20%	0	—	200	
V _{IH}	"H" input voltage	I _C ≤ 400mA	3.85	—	30	V
		I _C ≤ 200mA	3.4	—		
V _{IL}	"L" input voltage		0	—	0.6	V

ELECTRICAL CHARACTERISTICS (Unless otherwise noted, Ta = -20 ~ +75°C)

Symbol	Parameter	Test conditions	Limits			Unit
			min	typ*	max	
V (BR) CEO	Collector-emitter breakdown voltage	I _{CEO} = 100μA	50	—	—	V
V _{CE (sat)}	Collector-emitter saturation voltage	V _I = 3.85V, I _C = 400mA	—	1.3	2.4	V
		V _I = 3.4V, I _C = 200mA	—	1.0	1.6	
I _I	Input current	V _I = 3.85V	—	0.95	1.8	mA
		V _I = 25V	—	8.7	18	
V _F	Clamping diode forward voltage	I _F = 400mA	—	1.5	2.4	V
I _R	Clamping diode reverse current	V _R = 50V	—	—	100	μA
h _{FE}	DC amplification factor	V _{CE} = 4V, I _C = 350mA, Ta = 25°C	1000	2500	—	—

* : The typical values are those measured under ambient temperature (Ta) of 25°C. There is no guarantee that these values are obtained under any conditions.

SWITCHING CHARACTERISTICS (Unless otherwise noted, Ta = 25°C)

Symbol	Parameter	Test conditions	Limits			Unit
			min	typ	max	
t _{on}	Turn-on time	C _L = 15pF (note 1)	—	12	—	ns
t _{off}	Turn-off time		—	240	—	ns

M54585P/FP

8-UNIT 500mA DARLINGTON TRANSISTOR ARRAY WITH CLAMP DIODE

NOTE 1 TEST CIRCUIT

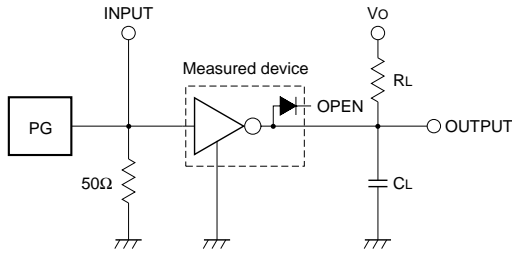

- (1) Pulse generator (PG) characteristics : PRR = 1kHz,
 $t_w = 10\mu s$, $t_r = 6ns$, $t_f = 6ns$, $Z_O = 50\Omega$
 $V_i = 3.85V$
- (2) Input-output conditions : $R_L = 25\Omega$, $V_o = 10V$
- (3) Electrostatic capacity C_L includes floating capacitance at connections and input capacitance at probes

TIMING DIAGRAM

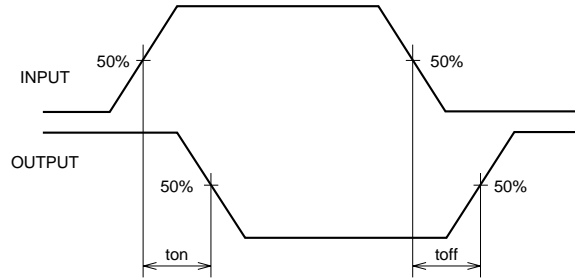

TYPICAL CHARACTERISTICS

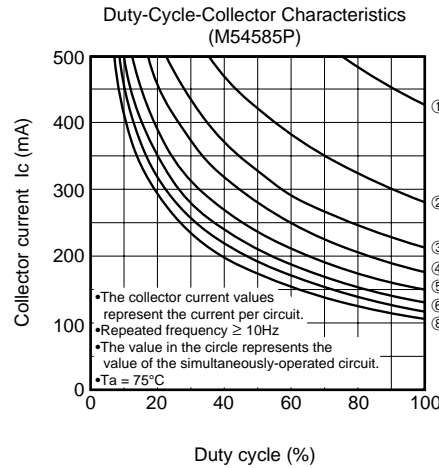
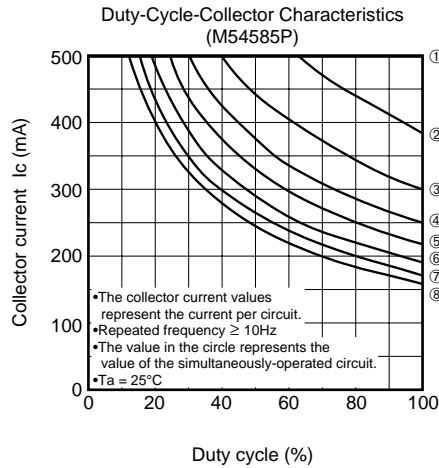
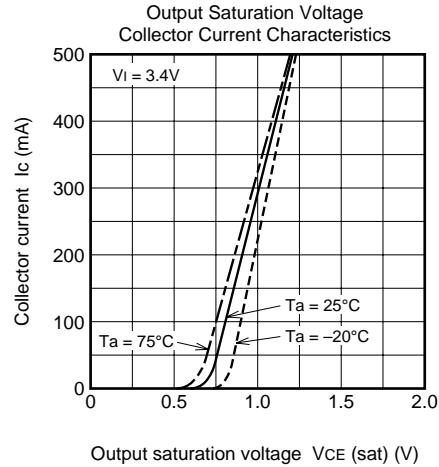
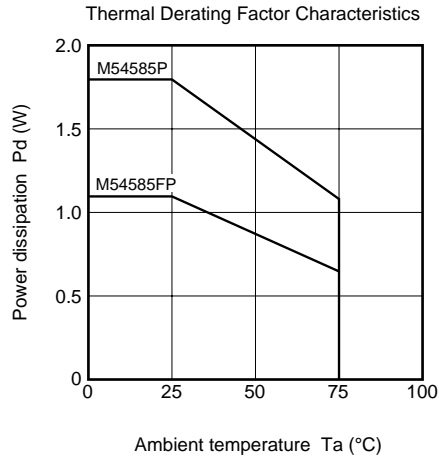

M54585P/FP

8-UNIT 500mA DARLINGTON TRANSISTOR ARRAY WITH CLAMP DIODE

