

Limit Switches - Prewired Type Metal Body

CARLO GAVAZZI



- Sealed with epoxy resin at the base of the box
- Degree of protection IP67
- Diecast zinc alloy body
- Positive Opening Operation (↻)
- Minimum Actuation Force/Torque
- Minimum Force to achieve Positive Opening Operation
- Precise operating points (consistency)
- Immune to electromagnetic disturbances
- Zb type contact blocks
- Current I_{th} = 10A
- Rated insulation voltage U_i = 500V
- UL, CSA, CE, RoHS
- Conform with IEC 947-5-1 (EN 60947-5-1)

Product Description

They are developed with very compact size, to enable its mounting on machine's moving member during adverse environmental conditions and controlling their position.

Ordering Key

PS21M-CS11RT-M00

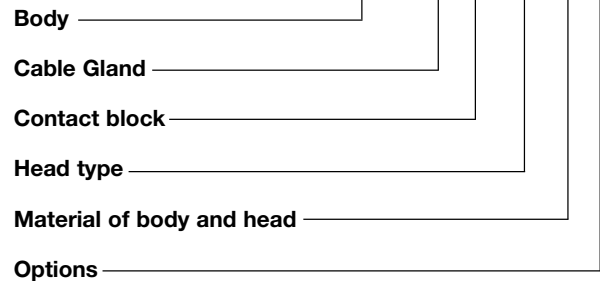

Description of the key codes

Body

PS21M | PS 30mm (fix 20mm) 1m cable lateral side (prewired)

Cable Gland

C | Prewired - std cable
U | Prewired - UL cable

Contact block

S11 | 1NO+1NC snap(+)
T11 | 1NO+1NC slow(+)

Material of body and head

M | Metal Body and Metal head

Options

00 | no option
OL | with fixing nuts (only with head type P0, PR, PY, P9, P8)

Head type

BE | nylon roller ext bent LEVER
BO | ball roller bent LEVER
BR | nylon roller int bent LEVER
L3 | adj square (3x3) steel rod LEVER
LA | adj Ø3 rod LEVER stainless steel rod
LB | nylon actuator with stainless steel spring
LF | adj fiberglass rod LEVER Ø3
LG | adj fiberglass rod LEVER Ø6
LN | adj nylon rod LEVER
LP | multidir nylon actuator with stainless steel spring
LS | stainless steel spring multidir actuator
LW | Stainless steel spring multidir actuator (cat Whisker)
LZ | Stainless steel spring actuator
P0 | metal plain PLUNGER
P8 | nylon cross roller PLUNGER with fixing nuts
P9 | cross metal roller PLUNGER
PH | metal PLUNGER +gasket
PR | metal roller PLUNGER
PY | nylon roller PLUNGER
R1 | adj LEVER with nylon roller
R2 | adj LEVER with stainless steel roller
RM | metal roller LEVER
RO | roller LEVER steel ball bearing
RS | metal roller LEVER
RT | nylon roller LEVER
W1 | adj LEVER with Ø50 rubber roller

Technical Data

Standards

Certifications – Approvals

Air temperature near the device

- during operation °C
- for storage °C

Mounting positions

Protection against electrical shocks (acc.to IEC 536)

Degree of protection (according to IEC 529 and EN 60 529)

Degree of protection (according to UL50)

Devices conform with international IEC 947-5-1 and European EN 60947-5-1 standards
UL, CSA, CE, RoHS

-25 ... +70

-40 ... +70

All positions are authorized

Class I

IP67

Type 4 - 4X - 6 enclosure

("outdoor use - raintight - watertight corrosion resistant")

Electrical Data

Rated insulation voltage U_i

-according to IEC 947-1 and EN 60-947-1

-according to UL 508, CSA C22-2 n°14

Rated impulse withstand voltage U_{imp} kV

(according to IEC 60947-1 and EN 60947-1)

Conventional enclosed thermal current I_{th} A

(according to IEC 60947-1 and EN 60947-5-1) ($\theta \leq 40^\circ\text{C}$)

Short-circuit protection - gG type fuses A

Rated operational current

I_e / AC-15 - acc.to IEC 60947-5-1

24Vac (50/60 Hz) A

120Vac (50/60 Hz) A

240Vac (50/60 Hz) A

I_e / DC-13 - acc.to IEC 60947-5-1

24Vdc A

110Vdc A

250Vdc A

Electrical durability (according to IEC 60497-5-1 annex C)

- max. switching frequency Cycles/h

- load factor

Mechanical durability

400V (degree of pollution 3)

B 300, R 300

4

5

6

5.0

3.0

1.5

1.1

0.22

0.1

Utilization categories AC-15 and DC-13 (see curves and value below)

3600

0.5

10 millions of operations

Diagram for snap action contact:

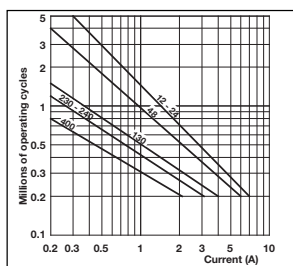
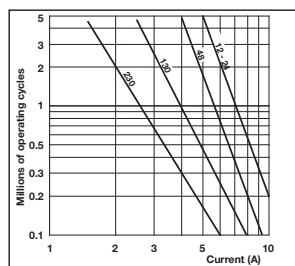

Diagram for slow action contact:



Electrical durability for DC-13 utilization category

Power breaking for a durability of 5 million operating cycles		
	Snap action	Slow action
Voltage 24V	9,5W	12W
Voltage 48V	6,8W	9W
Voltage 110V	3,6W	6W

Limit Switches - Miniature Type (PS21M) Metal Body IP67



▣ Cable Characteristics

C = Pre-wired, 1m standard cable 4x0.75mm²
U = Pre-wired, 1m UL cable 4x0.75mm²

(Different lengths available on request)

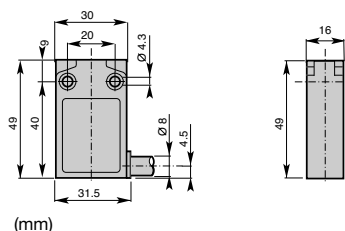

▲ Contact block (Zb type)

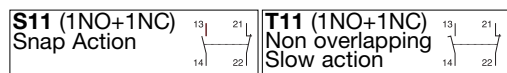

		S11		T11	
--	--	------------	--	------------	--

Conformity / \ominus (NC) / \ominus
Max. Actuation speed 0.5ms
Min. force or torque 15N / 30Nm
Weight 175g

Plain Plunger
Code PS21M- \square - \square - \square P0-M00

		S11		T11	
--	--	------------	--	------------	--

Conformity / \ominus (NC) / \ominus
Max. Actuation speed 0.1ms
Min. force or torque 10N / 30Nm
Weight 180g

Roller Plunger
Code Metal roller PS21M- \square - \square - \square PR-M00
 Nylon roller PS21M- \square - \square - \square PY-M00

		S11		T11	
--	--	------------	--	------------	--

Conformity / \ominus (NC) / \ominus
Max. Actuation speed 0.1ms
Min. force or torque 10N / 30Nm
Weight 180g

Cross roller plunger
Code Metal roller PS21M- \square - \square - \square P9-M00
 Nylon roller PS21M- \square - \square - \square P8-M00

		S11		T11	
--	--	------------	--	------------	--

Conformity / \ominus (NC) / \ominus
Max. Actuation speed 0.5ms
Min. force or torque 15N / 30Nm
Weight 180g

Plain plunger with dust protection cup
Code PS21M- \square - \square - \square PH-M00

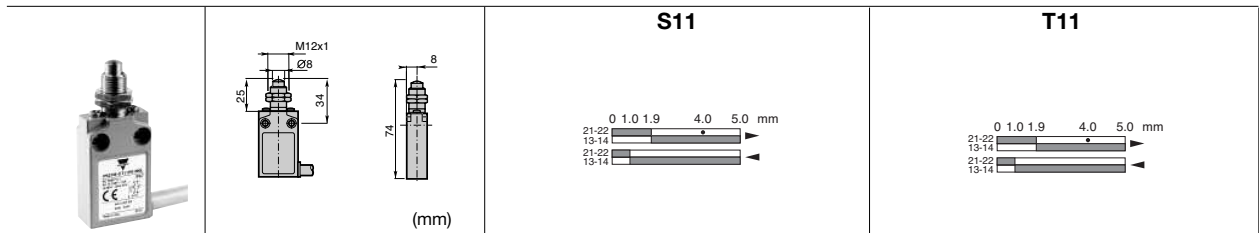

Conformity / \rightarrow (NC) / \rightarrow	Pain plunger with fixing nuts	Code PS21M- \square \blacktriangle P0-M0L
Max. Actuation speed 0.5ms		
Min. force or torque 15N / 30Nm		
Weight 190g		

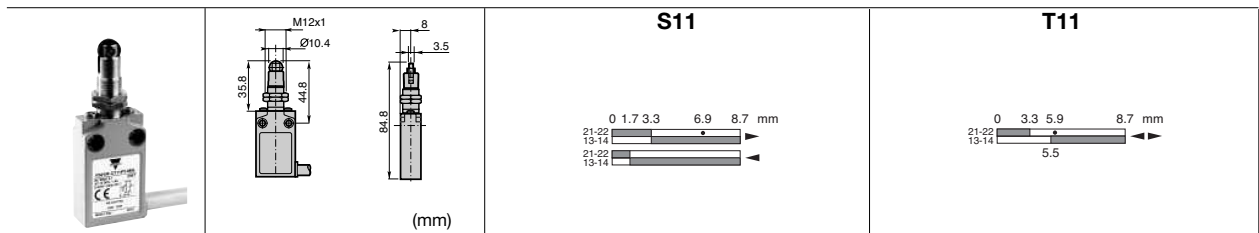

Conformity / \rightarrow (NC) / \rightarrow	Roller plunger with fixing nuts	Code metal roller PS21M- \square \blacktriangle PR-M0L nylon roller PS21M- \square \blacktriangle PY-M0L
Max. Actuation speed 0.1ms		
Min. force or torque 10N / 30Nm		
Weight 195g		

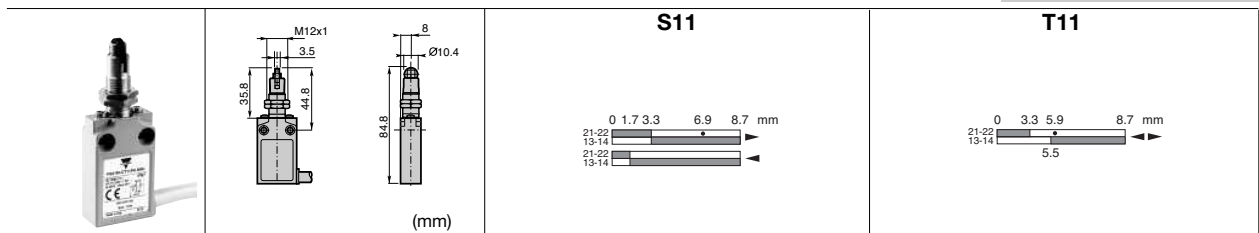

Conformity / \rightarrow (NC) / \rightarrow	Cross roller plunger with fixing nuts	Code metal roller PS21M- \square \blacktriangle P9-M0L nylon roller PS21M- \square \blacktriangle P8-M0L
Max. Actuation speed 0.1ms		
Min. force or torque 10N / 30Nm		
Weight 195g		

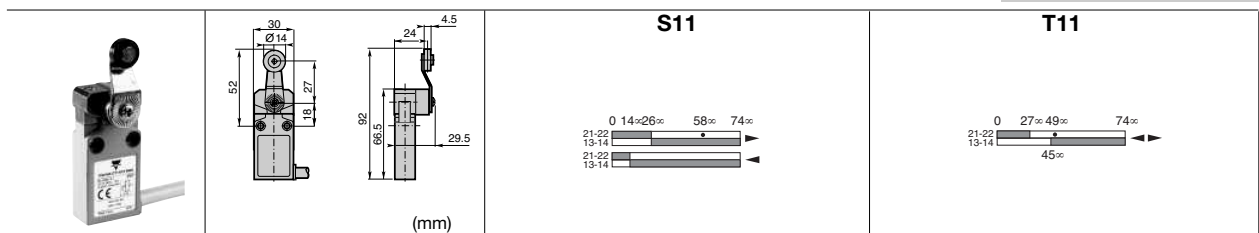

Conformity / \rightarrow (NC) / \rightarrow	Ø14 roller lever	Code nylon roller PS21M- \square \blacktriangle RT-M00 metal roller PS21M- \square \blacktriangle RS-M00 ball bearing PS21M- \square \blacktriangle RO-M00
Max. Actuation speed 1.5ms		
Min. force or torque 0.08N / 0.28Nm		
Weight 225g		

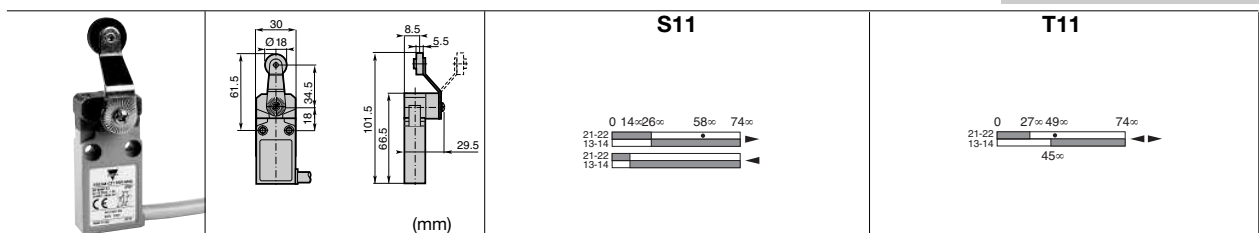

Conformity / \rightarrow (NC) / \rightarrow	Ø18 nylon roller lever	Code PS21M- \square \blacktriangle BR-M00
Max. Actuation speed 1.5ms		
Min. force or torque 0.08N / 0.28Nm		
Weight 230g		

Limit Switches - Miniature Type (PS21M) Metal Body IP67



▣ Cable Characteristics

C = Pre-wired, 1m standard cable 4x0.75mm²
U = Pre-wired, 1m UL cable 4x0.75mm²

(Different lengths available on request)

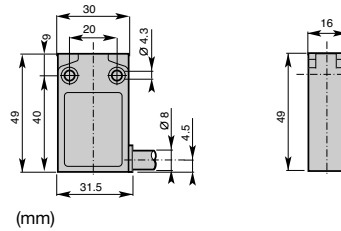

▲ Contact block (Zb type)

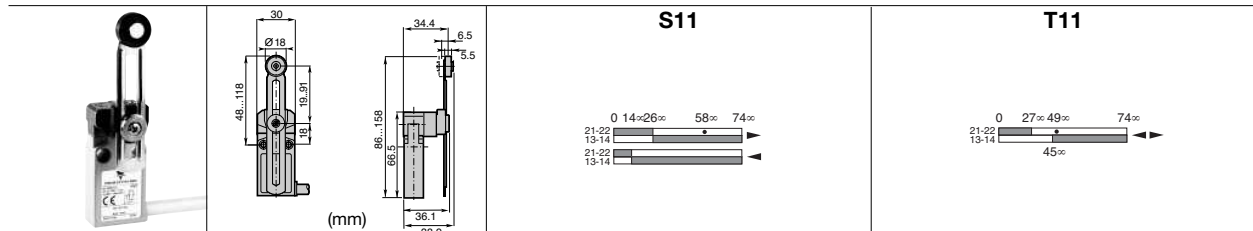
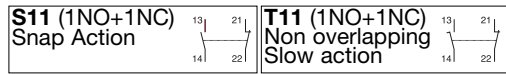

Conformity / (NC) /

Max. Actuation speed 1.5ms

Min. force or torque 0.08N / 0.28Nm

Weight 240g

Adjustable lever with Ø18 nylon roller

Code PS21M- R1-M00

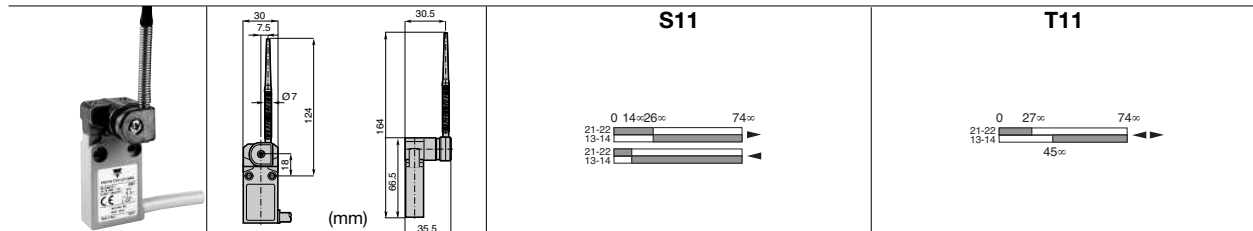

Conformity / (NC) /

Max. Actuation speed 1.5ms

Min. force or torque 0.08N / -

Weight 240g

Nylon actuator with stainless steel spring

Code PS21M- LB-M00

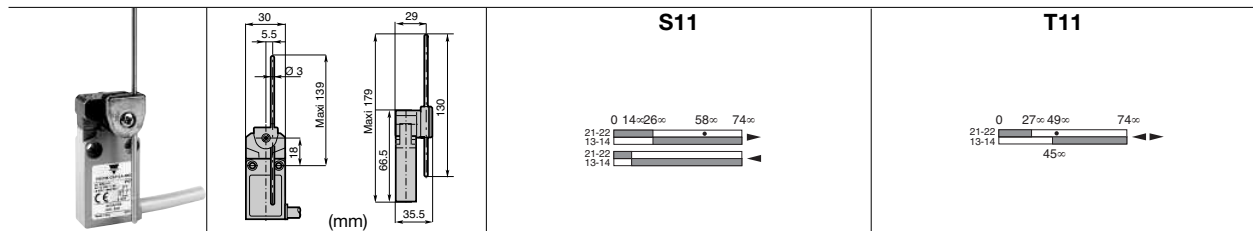

Conformity / (NC) /

Max. Actuation speed 1.5ms

Min. force or torque 0.08N / 0.28Nm

Weight 235g

Adjustable rod lever

Code stainless steel rod Ø3
fiberglass rod Ø3
square steel rod 3x3

PS21M- LA-M00
 PS21M- LF-M00
 PS21M- L3-M00

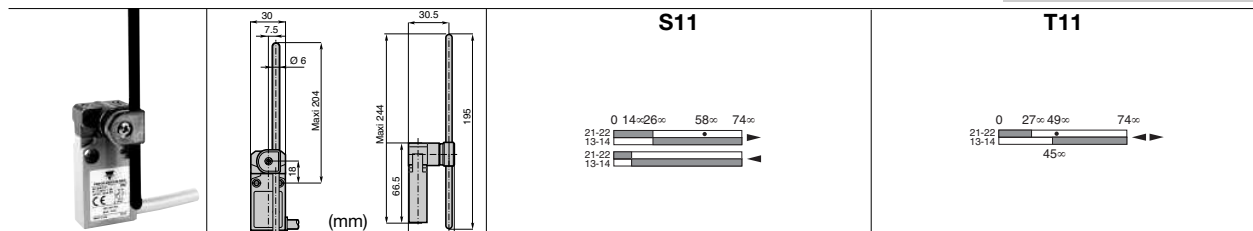

Conformity / (NC) /

Max. Actuation speed 1.5ms



Min. force or torque 0.08N / 0.28Nm

Weight 250g

Adjustable Ø6 rod lever

Code Nylon rod
fiberglass rod

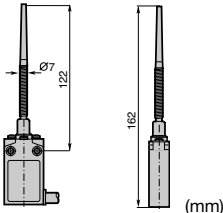
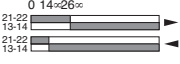
PS21M- LN-M00
 PS21M- LG-M00

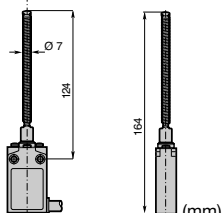
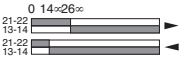
		<p>S11</p> 	
Conformity / \rightarrow (NC) / \rightarrow		Multidirectional nylon actuator with stainless steel spring	
Max. Actuation speed 1.0ms		Code PS21M-01LP-M00	
Min. force or torque 0.10N / -			
Weight 245g			
		<p>S11</p> 	
Conformity / \rightarrow (NC) / \rightarrow		Multidirectional actuator with stainless steel spring	
Max. Actuation speed 1.0ms		Code PS21M-01LS-M00	
Min. force or torque 0.10N / -			
Weight 250g			

Adjustement and utilization precautions

Position adjustment of lever

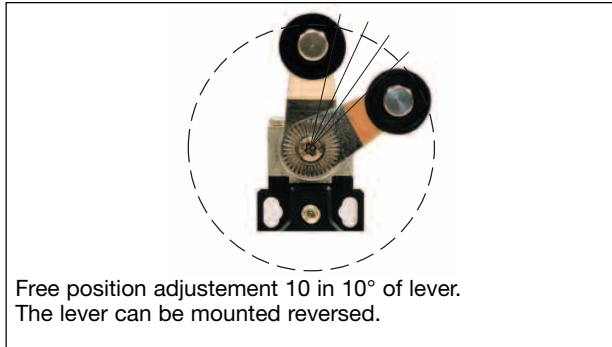

Plain plunger

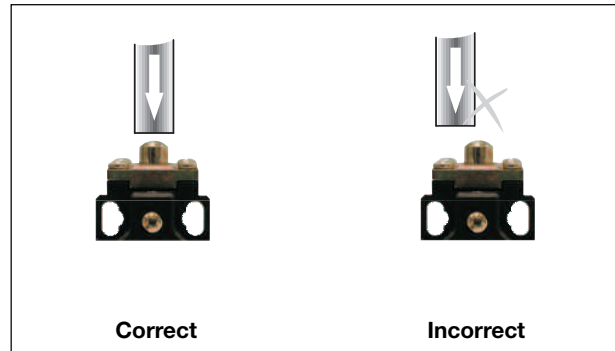

Roller plunger or Roller lever

