

ULN2001A/L THROUGH ULN2025A/L

IECO MFG.
APPROVALDESCLINE
CERTIFICATION

HIGH-VOLTAGE, HIGH-CURRENT DARLINGTON ARRAYS

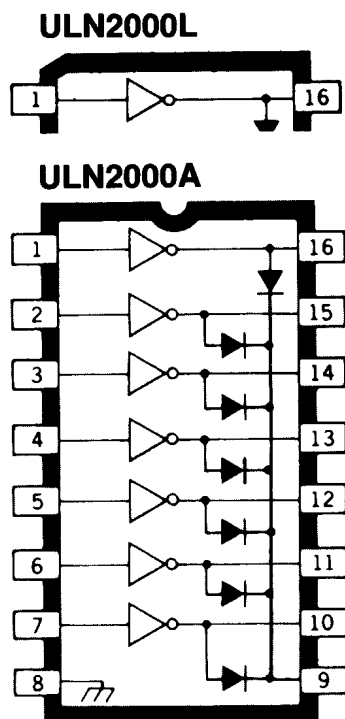

ABSOLUTE MAXIMUM RATINGS

Output Voltage, V_{CE}	
(ULN200X*, ULN201XA)	50 V
(ULM202X*)	95 V
Input Voltage, V_{IN}	
(ULN20X2, X3, X4)	30 V
(ULN20X5*)	15 V
Continuous Output Current, I_C	
(ULN200X*, ULN202X*)	500 mA
(ULN201XA)	600 mA
Continuous Input Current, I_{IN}	25 mA
Power Dissipation, P_D	
(one Darlington pair)	1.0 W
(total package)	See Graph
Operating Temperature	
Range, T_A	-20°C to +85°C
Storage Temperature	
Range, T_S	-55°C to +150°C

Note that the ULN2000A series (dual in-line package) and ULN2000L series (small-outline IC package) are electrically identical and share a common pin number assignment

Ideally suited for interfacing between low-level logic circuitry and multiple peripheral power loads, the Series ULN2000A/L high-voltage, high-current Darlington arrays feature continuous load current ratings to 600 mA for each of the seven drivers. At an appropriate duty cycle depending on ambient temperature and number of drivers turned ON simultaneously, typical power loads totaling over 260 W (400 mA x 7, 95 V) can be controlled. Typical loads include relays, solenoids, stepping motors, multiplexed LED and incandescent displays, and heaters. All devices feature open collector outputs with integral clamp diodes.

The Series ULN20x1A/L devices are general-purpose arrays which may be used with external input current limiting, or with most PMOS or CMOS logic directly.

The Series ULN20x2A/L is intended for use with 14 to 25 V PMOS logic. Each input has a series Zener diode and current limiting resistor. The Zener diode also provides excellent noise immunity for these devices.

The Series ULN20x3A/L has series input resistors selected for operation directly with 5 V TTL or CMOS. These devices will handle numerous interface needs — particularly those beyond the capabilities of standard logic buffers.

The Series ULN20x4A/L features series input resistors for operation directly from 6 to 15 V CMOS or PMOS logic outputs.

The Series ULN20x5A/L is designed for use with standard and Schottky TTL where higher output currents are required and loading of the logic output is not a concern. These devices will sink a minimum of 350 mA when driven from a TTL "totem pole" logic output.

The Series ULN200xA/L is the standard Darlington array. The outputs are capable of sinking 500 mA and will withstand at least 50 V in the OFF state. Outputs may be paralleled for higher load current capability. The Series ULN201xA devices are similar except that they will sink 600 mA. The Series ULN202xA/L will withstand 95 V in the OFF state.

These Darlington arrays are furnished in 16-pin dual in-line plastic packages (suffix A) and 16-lead surface-mountable SOICs (suffix L). All devices are pinned with outputs opposite inputs to facilitate ease of circuit board layout.

FEATURES

- TTL, DTL, MOS, or CMOS Compatible Inputs
- Output Current to 600 mA
- Output Voltage to 95 V
- Transient-Protected Outputs
- Dual In-Line Plastic Package or Small-Outline IC Package

x = digit to identify specific device. Characteristic shown applies to family of devices with remaining digits as shown.

SPRAGUE

SEMICONDUCTOR GROUP

SERIES ULN2000A/L HIGH-VOLTAGE, HIGH-CURRENT DARLINGTON ARRAYS

PARTIAL SCHEMATICS

ULN20X1* (Each Driver)

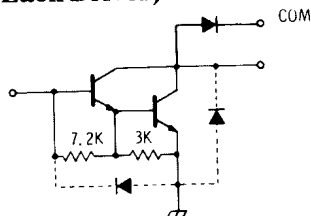

ULN20X2* (Each Driver)

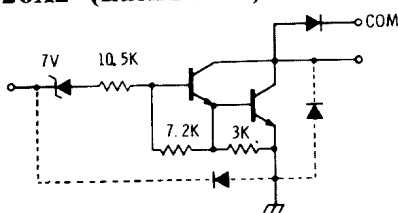

ULN20X3* (Each Driver)

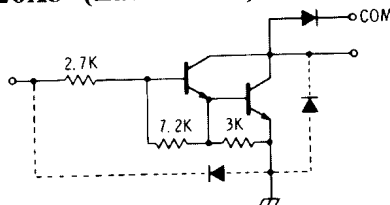

ULN20X4* (Each Driver)

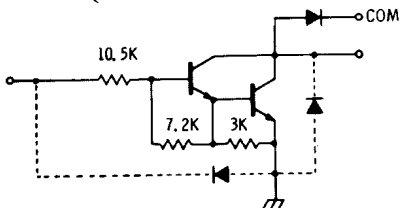

ULN20X5* (Each Driver)

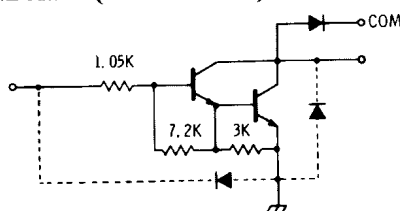

Device Number Designation

$V_{CE(MAX)}$	50 V	50 V	95 V
$I_C(MAX)$	500 mA	600 mA	500 mA
Logic	Part Number		
General Purpose PMOS, CMOS	ULN2001*	ULN2011A	ULN2021*
14-25 V PMOS	ULN2002*	ULN2012A	ULN2022*
5 V TTL, CMOS	ULN2003*	ULN2013A	ULN2023*
6-15 V CMOS, PMOS	ULN2004*	ULN2014A	ULN2024*
High-Output TTL	ULN2005*	ULN2015A	ULN2025*

ALLOWABLE AVERAGE PACKAGE POWER DISSIPATION

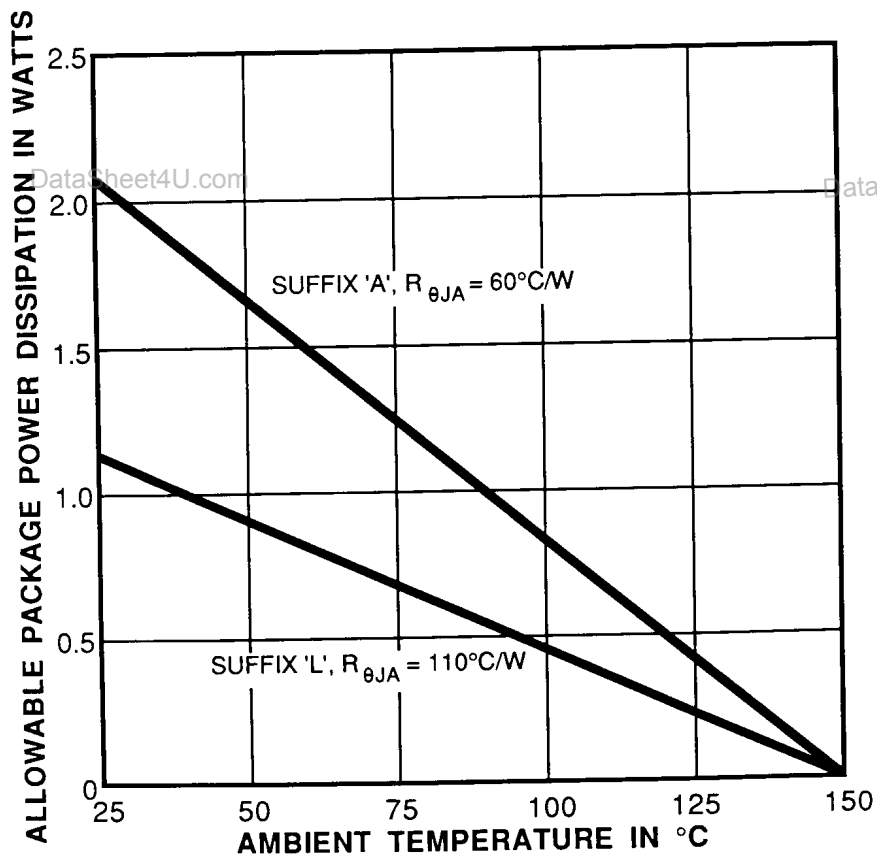

Dwg. GP-006

*Complete part number includes a final letter to indicate package (A = DIP, L = SOIC)

X = Digit to identify specific device. Specification shown applies to family of devices with remaining digits as shown.

SPRAGUE

115 Northeast Cutoff, Box 15036
Worcester, Massachusetts 01615-0036 (508) 853-5000 www.DataSheet4U.com
Copyright © 1988 Sprague Electric Company, April, 1988

SERIES ULN2000A/L

HIGH-VOLTAGE, HIGH-CURRENT DARLINGTON ARRAYS

TEST FIGURES

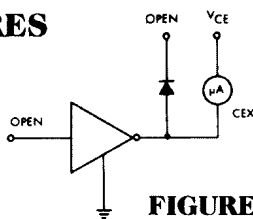

FIGURE 1A

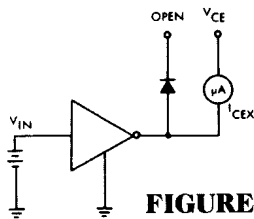

FIGURE 1B

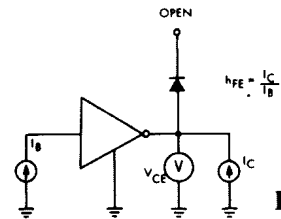

FIGURE 2

SERIES ULN2000A/L

ELECTRICAL CHARACTERISTICS AT +25°C (unless otherwise noted)

Characteristic	Symbol	Test Fig.	Applicable Devices	Test Conditions	Limits			Units
					Min.	Typ.	Max.	
Output Leakage Current	I_{CEX}	1A	All	$V_{CE} = 50\text{ V}, T_A = 25^\circ\text{C}$	—	—	50	μA
				$V_{CE} = 50\text{ V}, T_A = 70^\circ\text{C}$	—	—	100	μA
		1B	ULN2002*	$V_{CE} = 50\text{ V}, T_A = 70^\circ\text{C}, V_{IN} = 6.0\text{ V}$	—	—	500	μA
			ULN2004*	$V_{CE} = 50\text{ V}, T_A = 70^\circ\text{C}, V_{IN} = 1.0\text{ V}$	—	—	500	μA
Collector-Emitter Saturation Voltage	$V_{CE(SAT)}$	2	All	$I_C = 100\text{ mA}, I_B = 250\text{ }\mu\text{A}$	—	0.9	1.1	V
				$I_C = 200\text{ mA}, I_B = 350\text{ }\mu\text{A}$	—	1.1	1.3	V
				$I_C = 350\text{ mA}, I_B = 500\text{ }\mu\text{A}$	—	1.3	1.6	V
Input Current	$I_{IN(ON)}$	3	ULN2002*	$V_{IN} = 17\text{ V}$	—	0.82	1.25	mA
			ULN2003*	$V_{IN} = 3.85\text{ V}$	—	0.93	1.35	mA
			ULN2004*	$V_{IN} = 5.0\text{ V}$	—	0.35	0.5	mA
				$V_{IN} = 12\text{ V}$	—	1.0	1.45	mA
			ULN2005*	$V_{IN} = 3.0\text{ V}$	—	1.5	2.4	mA
	$I_{IN(OFF)}$	4	All	$I_C = 500\text{ }\mu\text{A}, T_A = 70^\circ\text{C}$	50	65	—	μA
Input Voltage	$V_{IN(ON)}$	5	ULN2002*	$V_{CE} = 2.0\text{ V}, I_C = 300\text{ mA}$	—	—	13	V
				$V_{CE} = 2.0\text{ V}, I_C = 200\text{ mA}$	—	—	2.4	V
			ULN2003*	$V_{CE} = 2.0\text{ V}, I_C = 250\text{ mA}$	—	—	2.7	V
				$V_{CE} = 2.0\text{ V}, I_C = 300\text{ mA}$	—	—	3.0	V
			ULN2004*	$V_{CE} = 2.0\text{ V}, I_C = 125\text{ mA}$	—	—	5.0	V
				$V_{CE} = 2.0\text{ V}, I_C = 200\text{ mA}$	—	—	6.0	V
				$V_{CE} = 2.0\text{ V}, I_C = 275\text{ mA}$	—	—	7.0	V
				$V_{CE} = 2.0\text{ V}, I_C = 350\text{ mA}$	—	—	8.0	V
			ULN2005*	$V_{CE} = 2.0\text{ V}, I_C = 350\text{ mA}$	—	—	2.4	V
D-C Forward Current Transfer Ratio	h_{FE}	2	ULN2001*	$V_{CE} = 2.0\text{ V}, I_C = 350\text{ mA}$	1000	—	—	
Input Capacitance	C_{IN}	—	All		—	15	25	pF
Turn-On Delay	t_{PLH}	8	All	$0.5 E_{in}$ to $0.5 E_{out}$	—	0.25	1.0	μs
Turn-Off Delay	t_{PHL}	8	All	$0.5 E_{in}$ to $0.5 E_{out}$	—	0.25	1.0	μs
Clamp Diode Leakage Current	I_R	6	All	$V_R = 50\text{ V}, T_A = 25^\circ\text{C}$	—	—	50	μA
				$V_R = 50\text{ V}, T_A = 70^\circ\text{C}$	—	—	100	μA
Clamp Diode Forward Voltage	V_F	7	All	$I_F = 350\text{ mA}$	—	1.7	2.0	V

*Complete part number includes suffix to identify package style: A = DIP, L = SOIC.

SEMICONDUCTOR GROUP

SERIES ULN2000A/L HIGH-VOLTAGE, HIGH-CURRENT DARLINGTON ARRAYS

TEST FIGURES

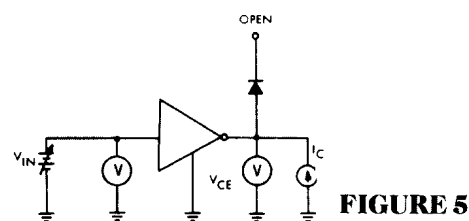
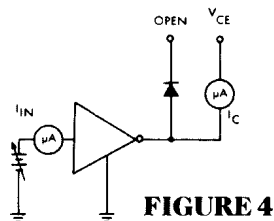
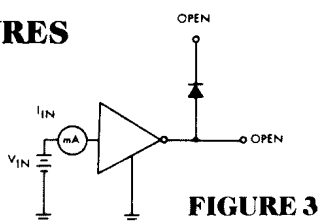

SERIES ULN2010A

ELECTRICAL CHARACTERISTICS AT 25°C (unless otherwise noted)

Characteristic	Symbol	Test Fig.	Applicable Devices	Test Conditions	Limits			Units
					Min.	Typ.	Max.	
Output Leakage Current	I_{CEX}	1A	All	$V_{CE} = 50\text{ V}, T_A = 25^\circ\text{C}$	—	—	50	μA
				$V_{CE} = 50\text{ V}, T_A = 70^\circ\text{C}$	—	—	100	μA
		1B	ULN2012A	$V_{CE} = 50\text{ V}, T_A = 70^\circ\text{C}, V_{IN} = 6.0\text{ V}$	—	—	500	μA
			ULN2014A	$V_{CE} = 50\text{ V}, T_A = 70^\circ\text{C}, V_{IN} = 1.0\text{ V}$	—	—	500	μA
Collector-Emitter Saturation Voltage	$V_{CE(SAT)}$	2	All	$I_C = 200\text{ mA}, I_B = 350\text{ }\mu\text{A}$	—	1.1	1.3	V
				$I_C = 350\text{ mA}, I_B = 500\text{ }\mu\text{A}$	—	1.3	1.6	V
				$I_C = 500\text{ mA}, I_B = 600\text{ }\mu\text{A}$	—	1.7	1.9	V
Input Current	$I_{IN(ON)}$	3	ULN2012A	$V_{IN} = 17\text{ V}$	—	0.82	1.25	mA
			ULN2013A	$V_{IN} = 3.85\text{ V}$	—	0.93	1.35	mA
			ULN2014A	$V_{IN} = 5.0\text{ V}$	—	0.35	0.5	mA
				$V_{IN} = 12\text{ V}$	—	1.0	1.45	mA
	ULN2015A	$V_{IN} = 3.0\text{ V}$	—	1.5	2.4	mA		
	$I_{IN(OFF)}$	4	All	$I_C = 500\text{ }\mu\text{A}, T_A = 70^\circ\text{C}$	50	65	—	μA
Input Voltage	$V_{IN(ON)}$	5	ULN2012A	$V_{CE} = 2.0\text{ V}, I_C = 500\text{ mA}$	—	—	17	V
			ULN2013A	$V_{CE} = 2.0\text{ V}, I_C = 250\text{ mA}$	—	—	2.7	V
				$V_{CE} = 2.0\text{ V}, I_C = 300\text{ mA}$	—	—	3.0	V
				$V_{CE} = 2.0\text{ V}, I_C = 500\text{ mA}$	—	—	3.5	V
				ULN2014A	$V_{CE} = 2.0\text{ V}, I_C = 275\text{ mA}$	—	—	7.0
			ULN2014A	$V_{CE} = 2.0\text{ V}, I_C = 350\text{ mA}$	—	—	8.0	V
				$V_{CE} = 2.0\text{ V}, I_C = 500\text{ mA}$	—	—	9.5	V
ULN2015A	$V_{CE} = 2.0\text{ V}, I_C = 500\text{ mA}$	—	—	2.6	V			
D-C Forward Current Transfer Ratio	h_{FE}	2	ULN2011A	$V_{CE} = 2.0\text{ V}, I_C = 350\text{ mA}$	1000	—	—	
				$V_{CE} = 2.0\text{ V}, I_C = 500\text{ mA}$	900	—	—	
Input Capacitance	C_{IN}	—	All		—	15	25	pF
Turn-On Delay	t_{ON}	8	All	$0.5 E_{in}$ to $0.5 E_{out}$	—	0.25	1.0	μs
Turn-Off Delay	t_{OFF}	8	All	$0.5 E_{in}$ to $0.5 E_{out}$	—	0.25	1.0	μs
Clamp Diode Leakage Current	I_R	6	All	$V_R = 50\text{ V}, T_A = 25^\circ\text{C}$	—	—	50	μA
				$V_R = 50\text{ V}, T_A = 70^\circ\text{C}$	—	—	100	μA
Clamp Diode Forward Voltage	V_F	7	All	$I_F = 350\text{ mA}$	—	1.7	2.0	V
				$I_F = 500\text{ mA}$	—	2.1	2.5	V

SPRAGUE

115 Northeast Cutoff, Box 15036
Worcester, Massachusetts 01615-0036 (508) 853-5000

www.DataSheet4U.com

SERIES ULN2000A/L HIGH-VOLTAGE, HIGH-CURRENT DARLINGTON ARRAYS

TEST FIGURES

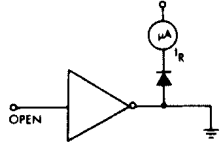

FIGURE 6

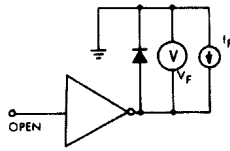

FIGURE 7

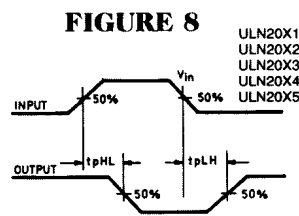
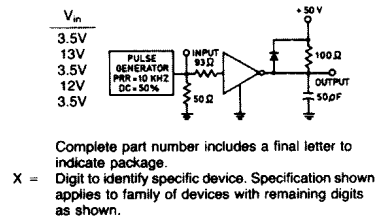

FIGURE 8

ULN20X1*
ULN20X2*
ULN20X3*
ULN20X4*
ULN20X5*



Complete part number includes a final letter to indicate package.
Digit to identify specific device. Specification shown applies to family of devices with remaining digits as shown.

SERIES ULN2020A/L

ELECTRICAL CHARACTERISTICS AT +25°C (unless otherwise noted)

Characteristic	Symbol	Test Fig.	Applicable Devices	Test Conditions	Limits			
					Min.	Typ.	Max.	Units
Output Leakage Current	I_{CEX}	1A	All	$V_{CE} = 50\text{ V}, T_A = 25^\circ\text{C}$	—	—	50	μA
				$V_{CE} = 50\text{ V}, T_A = 70^\circ\text{C}$	—	—	100	μA
		1B	ULN2022*	$V_{CE} = 50\text{ V}, T_A = 70^\circ\text{C}, V_{IN} = 6.0\text{ V}$	—	—	500	μA
			ULN2024*	$V_{CE} = 50\text{ V}, T_A = 70^\circ\text{C}, V_{IN} = 1.0\text{ V}$	—	—	500	μA
Collector-Emitter Saturation Voltage	$V_{CE(SAT)}$	2	All	$I_C = 100\text{ mA}, I_B = 250\text{ }\mu\text{A}$	—	0.9	1.1	V
				$I_C = 200\text{ mA}, I_B = 350\text{ }\mu\text{A}$	—	1.1	1.3	V
				$I_C = 350\text{ mA}, I_B = 500\text{ }\mu\text{A}$	—	1.3	1.6	V
Input Current	$I_{IN(ON)}$	3	ULN2022*	$V_{IN} = 17\text{ V}$	—	0.82	1.25	mA
			ULN2023*	$V_{IN} = 3.85\text{ V}$	—	0.93	1.35	mA
			ULN2024*	$V_{IN} = 5.0\text{ V}$	—	0.35	0.5	mA
				$V_{IN} = 12\text{ V}$	—	1.0	1.45	mA
			ULN2025*	$V_{IN} = 3.0\text{ V}$	—	1.5	2.4	mA
	$I_{IN(OFF)}$	4	All	$I_C = 500\text{ }\mu\text{A}, T_A = 70^\circ\text{C}$	50	65	—	μA
Input Voltage	$V_{IN(ON)}$	5	ULN2022*	$V_{CE} = 2.0\text{ V}, I_C = 300\text{ mA}$	—	—	13	V
				$V_{CE} = 2.0\text{ V}, I_C = 200\text{ mA}$	—	—	2.4	V
			ULN2023*	$V_{CE} = 2.0\text{ V}, I_C = 250\text{ mA}$	—	—	2.7	V
				$V_{CE} = 2.0\text{ V}, I_C = 300\text{ mA}$	—	—	3.0	V
				$V_{CE} = 2.0\text{ V}, I_C = 125\text{ mA}$	—	—	5.0	V
			ULN2024*	$V_{CE} = 2.0\text{ V}, I_C = 200\text{ mA}$	—	—	6.0	V
				$V_{CE} = 2.0\text{ V}, I_C = 275\text{ mA}$	—	—	7.0	V
				$V_{CE} = 2.0\text{ V}, I_C = 350\text{ mA}$	—	—	8.0	V
			ULN2025*	$V_{CE} = 2.0\text{ V}, I_C = 350\text{ mA}$	—	—	2.4	V
D-C Forward Current Transfer Ratio	h_{FE}	2	ULN2021*	$V_{CE} = 2.0\text{ V}, I_C = 350\text{ mA}$	1000	—	—	
Input Capacitance	C_{IN}	—	All		—	15	25	pF
Turn-On Delay	t_{PLH}	8	All	$0.5 E_{in}$ to $0.5 E_{out}$	—	0.25	1.0	μs
Turn-Off Delay	t_{PHL}	8	All	$0.5 E_{in}$ to $0.5 E_{out}$	—	0.25	1.0	μs
Clamp Diode Leakage Current	I_R	6	All	$V_R = 50\text{ V}, T_A = 25^\circ\text{C}$	—	—	50	μA
				$V_R = 50\text{ V}, T_A = 70^\circ\text{C}$	—	—	100	μA
Clamp Diode Forward Voltage	V_F	7	All	$I_F = 350\text{ mA}$	—	1.7	2.0	V

*Complete part number includes suffix to identify package style: A = DIP, L = SOIC.

SEMICONDUCTOR GROUP

www.DataSheet4U.com

SERIES ULN2000A/L HIGH-VOLTAGE, HIGH-CURRENT DARLINGTON ARRAYS

PEAK COLLECTOR CURRENT AS A FUNCTION OF DUTY CYCLE (Dual In-line Packaged Devices)

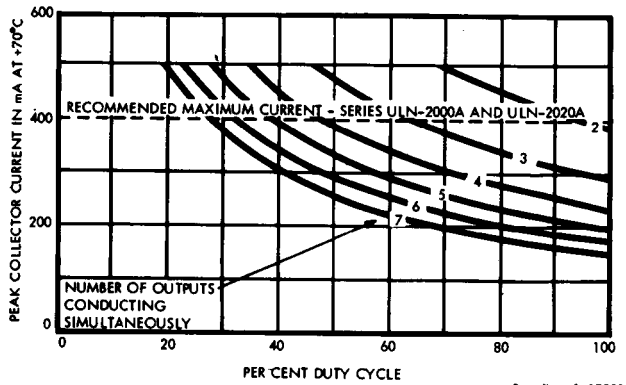

TYPICAL APPLICATIONS

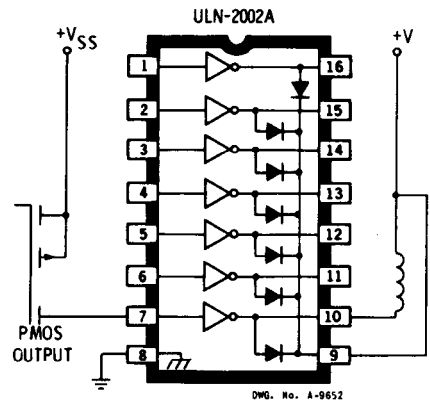

(Small Outline Packaged Devices)

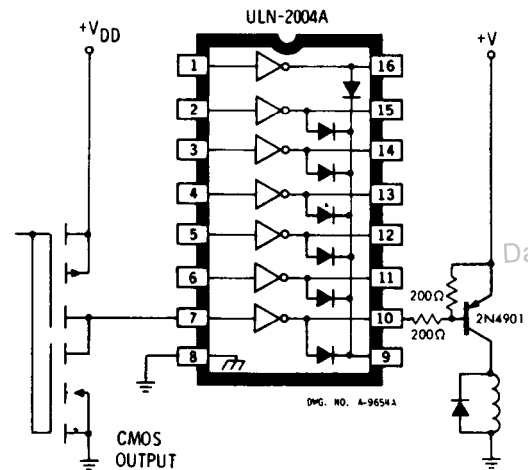
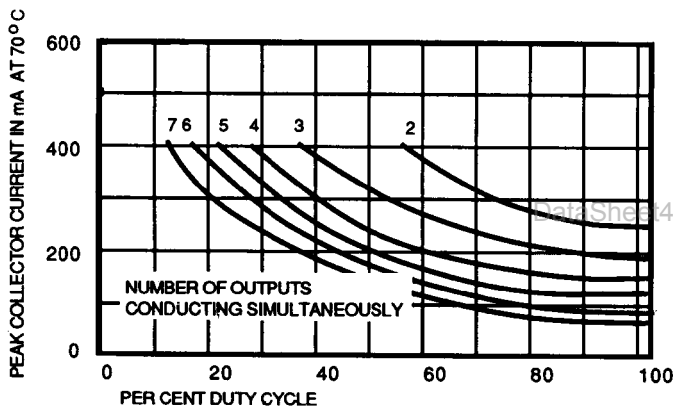

COLLECTOR CURRENT AS A FUNCTION OF INPUT CURRENT

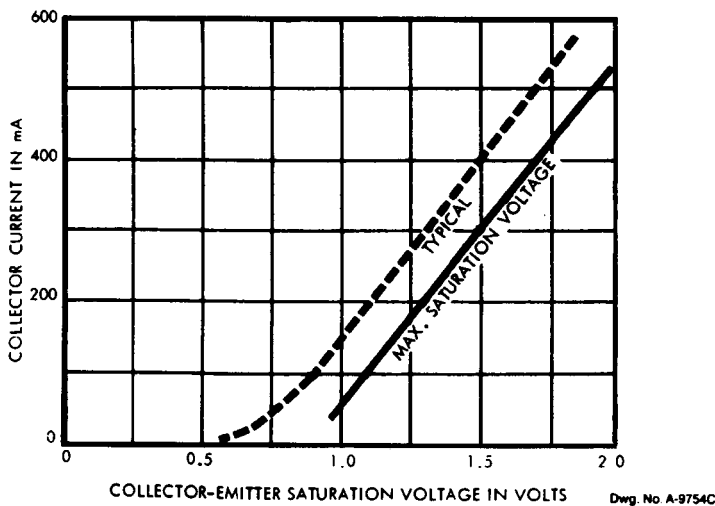

COLLECTOR CURRENT AS A FUNCTION OF INPUT CURRENT

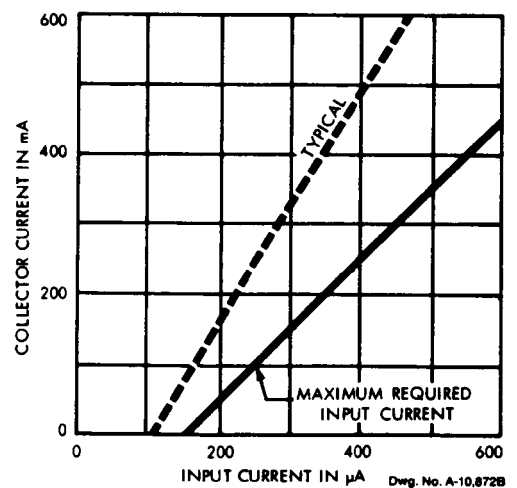

SPRAGUE

115 Northeast Cutoff, Box 15036
Worcester, Massachusetts 01615-0036 (508) 853-5000

SERIES ULN2000A/L HIGH-VOLTAGE, HIGH-CURRENT DARLINGTON ARRAYS

TYPICAL APPLICATIONS

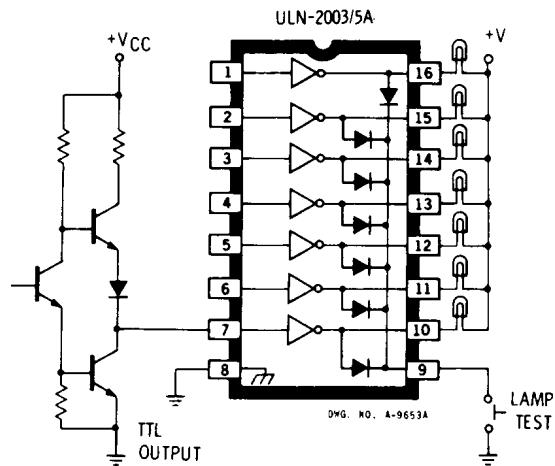

INPUT CURRENT AS A FUNCTION OF INPUT VOLTAGE

SERIES ULN2002A/L

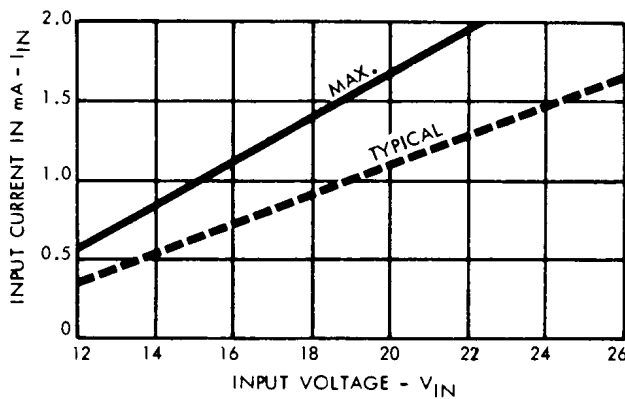

SERIES ULN2003A/L

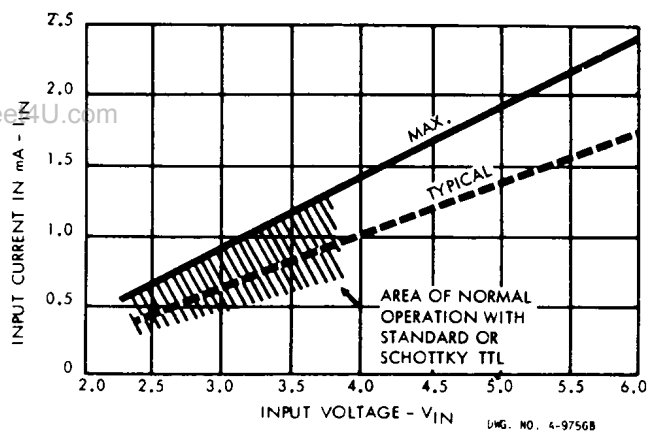
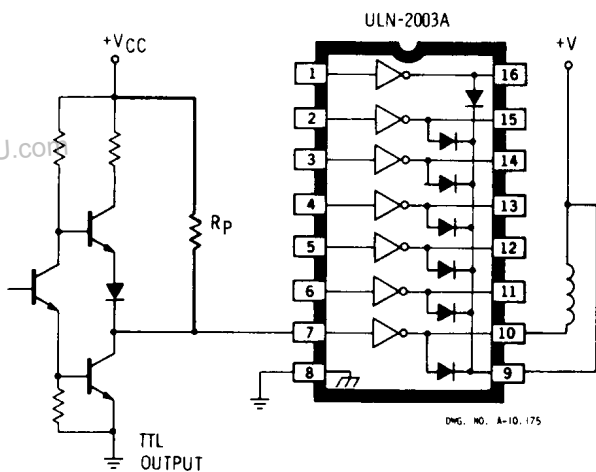

SERIES ULN2005A/L

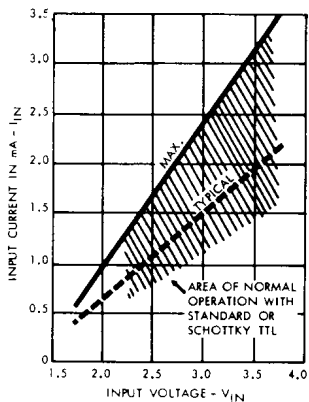

SERIES ULN2004A/L

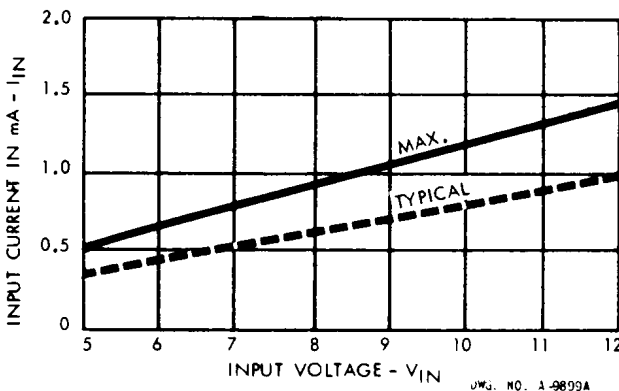

SEMICONDUCTOR GROUP

SERIES ULN2000A/L HIGH-VOLTAGE, HIGH-CURRENT DARLINGTON ARRAYS

PLASTIC SOIC

**DIMENSIONS IN INCHES
(BASED ON 1 mm = 0.03937")**

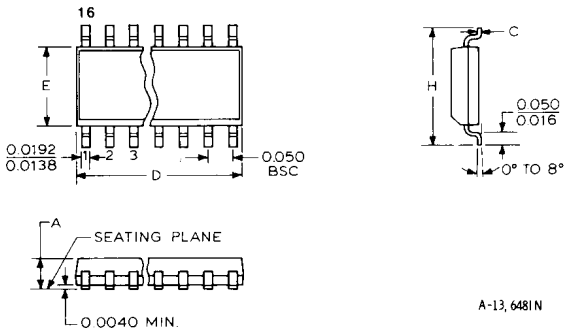

A	Seated Height	0.0532/0.0688
C	Lead Thickness	0.0075/0.0098
D	Body Length	0.3859/0.3937
E	Body Width	0.1497/0.1574
H	Overall Width	0.2284/0.2440

PLASTIC DIP

DIMENSIONS IN INCHES

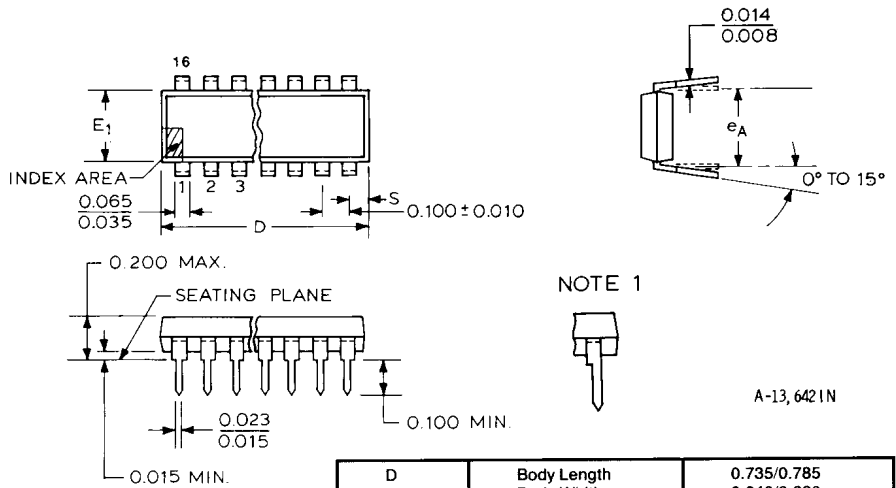

D	Body Length	0.735/0.785
E ₁	Body Width	0.240/0.260
e _A	Row Spacing	0.300 BSC
S	Lead CL to End	0.025 REF

DIMENSIONS IN MILLIMETERS

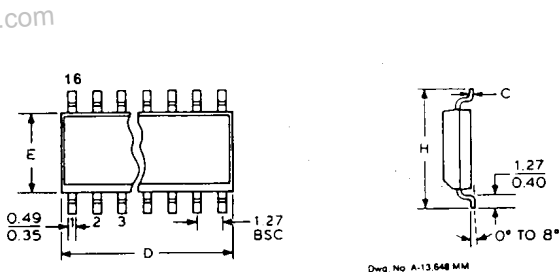

A	Seated Height	1.35/1.75
C	Lead Thickness	0.19/C.25
D	Body Length	9.80/10.0
E	Body Width	3.80/4.00
H	Overall Width	5.80/6.20

DIMENSIONS IN MILLIMETERS (BASED ON 1" = 25.40 mm)

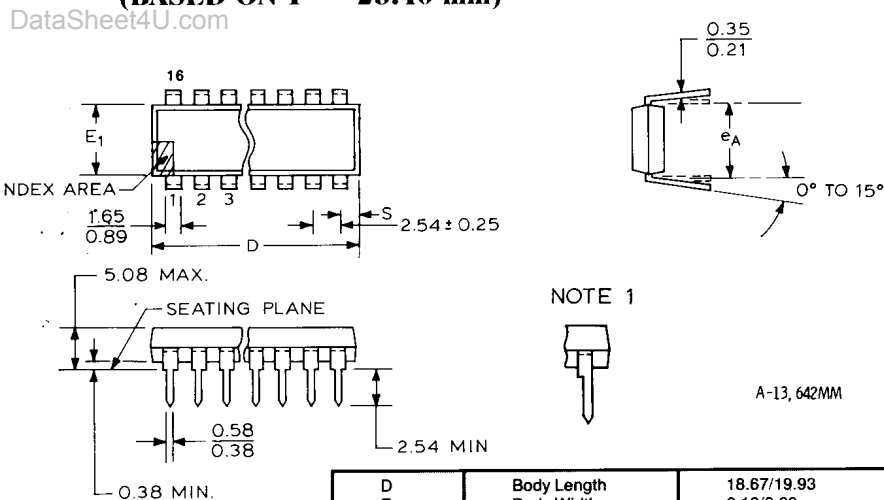

D	Body Length	18.67/19.93
E ₁	Body Width	6.10/6.60
e _A	Row Spacing	7.62 BSC
S	Lead CL to End	0.64 REF

1. Leads 1, 8, 9, and 16 may be half-leads at vendor's option.

In the construction of the components described, the full intent of the specification will be met. The Sprague Electric Company, however, reserves the right to make, from time to time, such departures from the detail specifications as may be required to permit improvements in the design of its products. Components made under military approvals will be in accordance with the approval requirements.

The information included herein is believed to be accurate and reliable. However, the Sprague Electric Company assumes no responsibility for its use; nor for any infringements of patents or other rights of third parties which may result from its use.

- A. Dimensions shown as ___ / ___ are Min./Max.
- B. Lead thickness is measured at seating plane or below.
- C. Lead spacing tolerance is non-cumulative.
- D. Exact body and lead configuration at vendor's option within limits shown.
- E. Lead gauge plane is 0.030" (7.62 mm) max. below seating plane.

SPRAGUE

115 Northeast Cutoff, Box 15036
Worcester, Massachusetts 01615-0036 (508) 853-5000 www.DataSheet4U.com

008590 ✓ - -