

Contents

Features	1
Applications	1
Dimensions (22-pin SOP)	2
Pin Assignment	2
Terminal Functions	2
Block Diagram	3
Absolute Maximum Ratings.....	3
Recommended Operating Conditions.....	3
DC Characteristics.....	4
Instructions	6
Application Example (S-1462AF).....	6

The S-1462AF/14L62AF 4-bit microcomputer integrates 10-bit programmable counter, watchdog timer, and 8-bit programmable timer on one chip. Driven by batteries, this microcomputer is ideal for compact portable equipment.

S-14L62AF is low voltage operating version of S-1462AF.

■ **Feature**

- Si gate CMOS process
- Low power consumption
- Single power supply: 2.2 V min.(for S-1462AF) , 1.2 V min.(for S-14L62AF)
- High-speed operation: 1 MHz max.
- ROM: 2 K×16 bits
- RAM: 128×4 bits
- 14 I/O lines
- 2 timers: timer, programmable counter
- Built-in watchdog timer
- Interrupt function: Two (Internal)
- Standby function
- Instruction execution time: 4.0 μ s /1 MHz
- Instruction: 35 basic instruction sets (166 if addressing modes are included)
16-level subroutine nesting
- 22-pin SOP (terminal distance: 1.27 mm)

■ **Applications**

- Presetable remote controller
- Compact portable equipment, others

CMOS 4-bit 1-chip MICROCOMPUTER
S-1462AF/14L62AF

■ **Dimensions (22-pin SOP)**

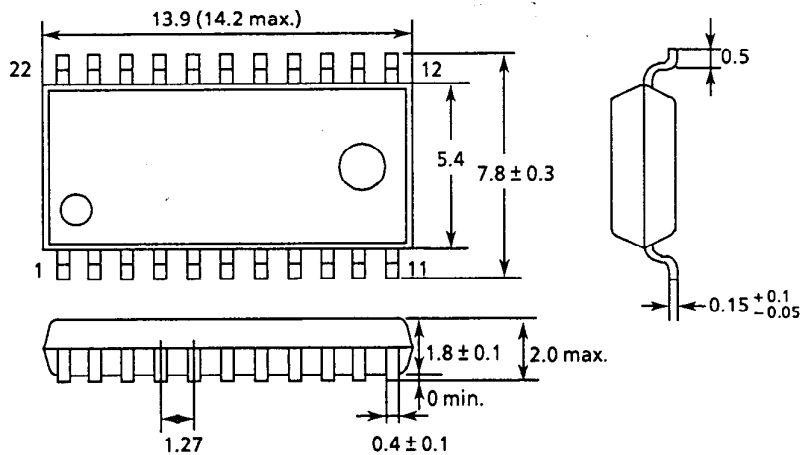

Figure 1

Unit : mm

■ **Pin Assignments**

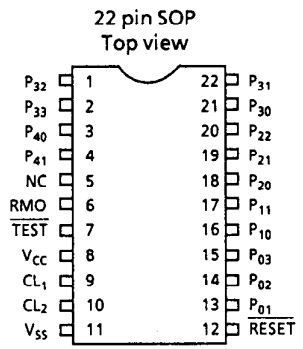

Figure 2

■ **Terminal Functions**

Table 1

Name	I/O	Functions
V _{SS}	—	GND potential terminal
V _{CC}	—	Positive power supply
TEST	Input	Test input terminal (built-in pull-up resistor)
RESET	Input	Reset input terminal (built-in pull-up resistor)
CL ₁	—	Ceramic oscillator connection terminal for system clock oscillation, external clock input
CL ₂	—	Ceramic oscillator connection terminal for system clock oscillation
RMO	Output	Remote control signal output terminal
P ₀₁ to P ₀₃	I/O	Port 0 input/output pins, whose directions are selected in bit units (pull-up resistor or Nch opendrain can be selected by mask option)
P ₁₀ , P ₁₁	Input	Port 1 input pins (built-in pull-up resistor)
P ₂₀ to P ₂₂	Input	Port 2 input pins (built-in pull-up resistor)
P ₃₀ to P ₃₃	Output	Port 3 output pins (Nch opendrain output can be selected by mask option)
P ₄₀ , P ₄₁	Output	Port 4 output pins (Nch opendrain output can be selected by mask option)

■ Block Diagram

The S-1462/L62AF blocks connect with a 4-bit data bus (DB), 4-bit address bus (AB), 4-bit RAM address bus (RA), and 12-bit operation bus (OB).

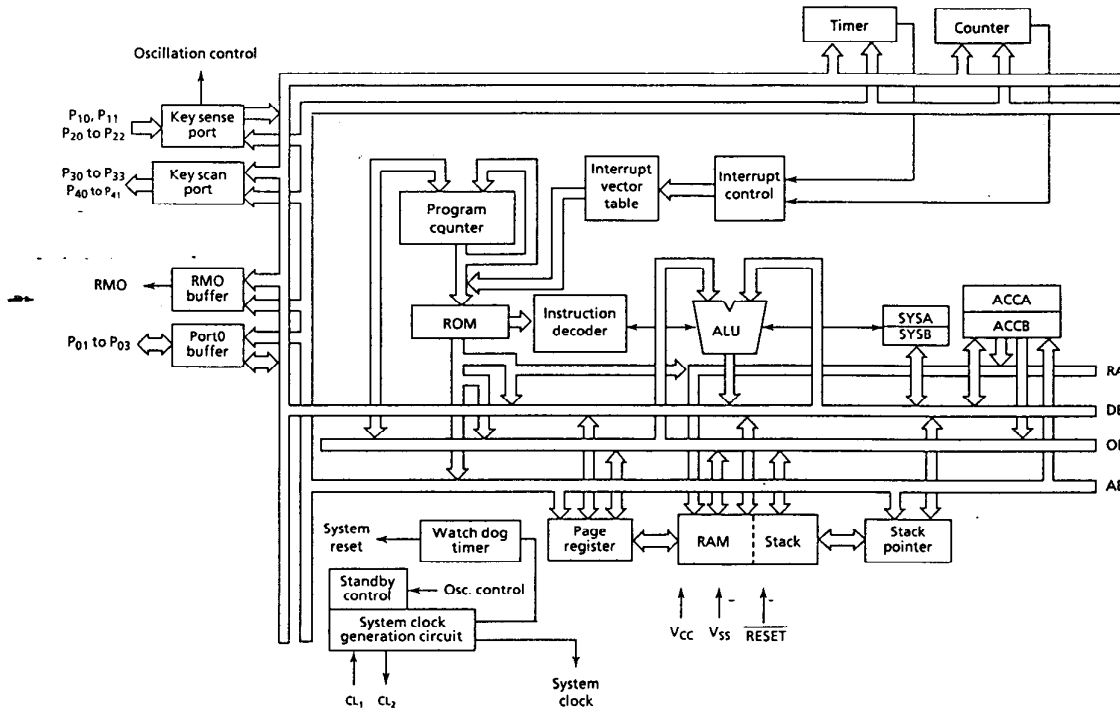

Figure 3

■ Absolute Maximum Ratings

Table 2

Item	Symbol	Conditions	Rating	Unit
Storage temperature	T_{stg}		-40 to +125	°C
Operating temperature	T_{opr}		-10 to +70	°C
Power supply voltage	V_{CC}	$T_a = 25^\circ\text{C}$ S-1462AF	-0.3 to +7.0	V
Power supply voltage	V_{CC}	$T_a = 25^\circ\text{C}$ S-14L62AF	-0.3 to +4.0	V
Input voltage	V_{IN}	$T_a = 25^\circ\text{C}$	$V_{SS}-0.3$ to $V_{CC}+0.3$	V
Output voltage	V_{OUT}	$T_a = 25^\circ\text{C}$	V_{SS} to V_{CC}	V
Power consumption	P_d	$T_a = 25^\circ\text{C}$	300	mW

■ Recommended Operating Conditions

Table 3

($T_a = -10^\circ\text{C}$ to $+70^\circ\text{C}$)

Item	Symbol	Conditions	Min.	Typ.	Max.	Unit
Power supply voltage	V_{CC}	System clock: 1 MHz for S-1462AF	2.2	—	6.0	V
Power supply voltage	V_{CC}	System clock: 1 MHz for S-14L62AF	1.2	—	3.6	V
Input voltage	V_{IN}		0	—	V_{CC}	V
System clock frequency	f_{sys}	$V_{CC} = 2.2$ to 6.0 V for S-1462AF	0.2	—	1.0	MHz
System clock frequency	f_{sys}	$V_{CC} = 1.2$ to 3.6 V for S-14L62AF	0.2	—	1.0	MHz

CMOS 4-bit 1-chip MICROCOMPUTER

S-1462AF/14L62AF

DC Characteristics

1. S-1462AF ($V_{CC} = 3V$)

Table 4

($T_a = -10^\circ C$ to $+70^\circ C$, $V_{CC} = 3V$)

Item	Symbol	Conditions	Min.	Typ.	Max.	Unit
Operating current consumption	I_{CCO}	$f_O = 1$ MHz, No load	—	0.25	0.7	mA
Standby current consumption	I_{CCS}	At OFF mode	—	0.1	2.0	μA
High level input voltage	V_{IH}		$0.8 \times V_{CC}$	—	—	V
Low level input voltage	V_{IL}		—	—	$0.2 \times V_{CC}$	V
High level input leakage current	I_{LH}	All input terminals* $V_{IN} = V_{CC}$	—	—	1	μA
Low level input leakage current	I_{LL}	Without pull-up resistor, P_{01} to P_{03} , $V_{IN} = V_{SS}$	-1	—	—	μA
High level input current	I_{IH}	RESET, $V_{IN} = V_{CC} - 0.3V$	-9	—	-0.9	μA
Low level input current 1	I_{IL1}	With pull-up resistor, P_{01} to P_{03} , P_{10} , P_{11} , P_{20} to P_{22} , $V_{IN} = V_{SS}$	-90	-30	-10	μA
Low level input current 2	I_{IL2}	RESET, $V_{IN} = V_{SS}$	-6	-2	-0.6	μA
Low level input current 3	I_{IL3}	TEST, $V_{IN} = V_{SS}$	-30	-10	-3	μA
High level output current 1	I_{OH1}	RMO, $V_{OUT} = 2.1V$	—	—	-5.0	mA
High level output current 2	I_{OH2}	P_{01} to P_{03} , P_{30} to P_{33} , P_{40} , P_{41} , $V_{OUT} = 2.6V$	—	—	-100	μA
Low level output current 1	I_{OL1}	RMO, $V_{OUT} = 0.4V$	250	—	—	μA
Low level output current 2	I_{OL2}	P_{01} to P_{03} , P_{30} to P_{33} , P_{40} , P_{41} , $V_{OUT} = 0.4V$	1.0	—	—	mA
Schmitt hysteresis width	V_{WD}		—	1.0	—	V

* TEST, RESET, P_{01} to P_{03} , P_{10} , P_{11} , P_{20} to P_{22}

2. S-1462AF ($V_{CC} = 5V$)

Table 5

($T_a = -10^\circ C$ to $+70^\circ C$, $V_{CC} = 5V$)

Item	Symbol	Conditions	Min.	Typ.	Max.	Unit
Operating current consumption	I_{CCO}	$f_O = 1$ MHz, No load	—	0.6	1.2	mA
Standby current consumption	I_{CCS}	At OFF mode	—	0.1	5.0	μA
High level input voltage	V_{IH}		$0.8 \times V_{CC}$	—	—	V
Low level input voltage	V_{IL}		—	—	$0.2 \times V_{CC}$	V
High level input leakage current	I_{LH}	All input terminals* $V_{IN} = V_{CC}$	—	—	1	μA
Low level input leakage current	I_{LL}	Without pull-up resistor, P_{01} to P_{03} , $V_{IN} = V_{SS}$	-1	—	—	μA
High level input current	I_{IH}	RESET, $V_{IN} = V_{CC} - 0.3V$	-15	—	-1.5	μA
Low level input current 1	I_{IL1}	With pull-up resistor, P_{01} to P_{03} , P_{10} , P_{11} , P_{20} to P_{22} , $V_{IN} = V_{SS}$	-230	-90	-30	μA
Low level input current 2	I_{IL2}	RESET, $V_{IN} = V_{SS}$	-15	-6	-2.4	μA
Low level input current 3	I_{IL3}	TEST, $V_{IN} = V_{SS}$	-75	-30	-12	μA
High level output current 1	I_{OH1}	RMO, $V_{OUT} = 4.1V$	—	—	-7	mA
High level output current 2	I_{OH2}	P_{01} to P_{03} , P_{30} to P_{33} , P_{40} , P_{41} , $V_{OUT} = 4.6V$	—	—	-250	μA
Low level output current 1	I_{OL1}	RMO, $V_{OUT} = 0.4V$	450	—	—	μA
Low level output current 2	I_{OL2}	P_{01} to P_{03} , P_{30} to P_{33} , P_{40} , P_{41} , $V_{OUT} = 0.4V$	1.5	—	—	mA
Schmitt hysteresis width	V_{WD}		—	2.2	—	V

* TEST, RESET, P_{01} to P_{03} , P_{10} , P_{11} , P_{20} to P_{22}

3. S-14L62AF ($V_{CC} = 1.5\text{ V}$)

Table 6

($T_a = -10^\circ\text{C}$ to $+70^\circ\text{C}$, $V_{CC} = 1.5\text{ V}$)

Item	Symbol	Conditions	Min.	Typ.	Max.	Unit
Operating current consumption	I_{CCO}	$f_O = 1\text{ MHz}$, No load	—	0.1	0.3	mA
Standby current consumption	I_{CCS}	At OFF mode	—	1	10	μA
High level input voltage	V_{IH}		$0.8 \times V_{CC}$	—	—	V
Low level input voltage	V_{IL}		—	—	$0.2 \times V_{CC}$	V
High level input leakage current	I_{LH}	All input terminals* $V_{IN} = V_{CC}$	—	—	1	μA
Low level input leakage current	I_{LL}	Without pull-up resistor, P_{01} to P_{03} , $V_{IN} = V_{SS}$	-1	—	—	μA
High level input current	I_{IH}	$\overline{\text{RESET}}$, $V_{IN} = V_{CC} - 0.3\text{ V}$	-4	—	-1	μA
Low level input current 1	I_{IL1}	With pull-up resistor, P_{01} to P_{03} , P_{10} , P_{11} , P_{20} to P_{22} , $V_{IN} = V_{SS}$	-30	-10	-3	μA
Low level input current 2	I_{IL2}	$\overline{\text{RESET}}$, $V_{IN} = V_{SS}$	-2	-0.6	-0.2	μA
Low level input current 3	I_{IL3}	$\overline{\text{TEST}}$, $V_{IN} = V_{SS}$	-8	-2	-0.5	μA
High level output current 1	I_{OH1}	RMO, $V_{OUT} = 1.1\text{ V}$	—	—	-2	mA
High level output current 2	I_{OH2}	P_{01} to P_{03} , P_{30} to P_{33} , P_{40} , P_{41} , $V_{OUT} = 1.1\text{ V}$	—	—	-100	μA
Low level output current 1	I_{OL1}	RMO, $V_{OUT} = 0.4\text{ V}$	200	—	—	μA
Low level output current 2	I_{OL2}	P_{01} to P_{03} , P_{30} to P_{33} , P_{40} , P_{41} , $V_{OUT} = 0.4\text{ V}$	0.5	—	—	mA
Schmitt hysteresis width	V_{WD}		—	0.4	—	V

* $\overline{\text{TEST}}$, $\overline{\text{RESET}}$, P_{01} to P_{03} , P_{10} , P_{11} , P_{20} to P_{22}

4. S-14L62AF ($V_{CC} = 3\text{ V}$)

Table 7

($T_a = -10^\circ\text{C}$ to $+70^\circ\text{C}$, $V_{CC} = 3\text{ V}$)

Item	Symbol	Conditions	Min.	Typ.	Max.	Unit
Operating current consumption	I_{CCO}	$f_O = 1\text{ MHz}$, No load	—	0.5	1.0	mA
Standby current consumption	I_{CCS}	At OFF mode	—	1	15	μA
High level input voltage	V_{IH}		$0.8 \times V_{CC}$	—	—	V
Low level input voltage	V_{IL}		—	—	$0.2 \times V_{CC}$	V
High level input leakage current	I_{LH}	All input terminals* $V_{IN} = V_{CC}$	—	—	1	μA
Low level input leakage current	I_{LL}	Without pull-up resistor, P_{01} to P_{03} , $V_{IN} = V_{SS}$	-1	—	—	μA
High level input current	I_{IH}	$\overline{\text{RESET}}$, $V_{IN} = V_{CC} - 0.3\text{ V}$	-8	—	-2	μA
Low level input current 1	I_{IL1}	With pull-up resistor, P_{01} to P_{03} , P_{10} , P_{11} , P_{20} to P_{22} , $V_{IN} = V_{SS}$	-120	-50	-20	μA
Low level input current 2	I_{IL2}	$\overline{\text{RESET}}$, $V_{IN} = V_{SS}$	-10	-4	-1.5	μA
Low level input current 3	I_{IL3}	$\overline{\text{TEST}}$, $V_{IN} = V_{SS}$	-40	-16	-6	μA
High level output current 1	I_{OH1}	RMO, $V_{OUT} = 2.6\text{ V}$	—	—	-3	mA
High level output current 2	I_{OH2}	P_{01} to P_{03} , P_{30} to P_{33} , P_{40} , P_{41} , $V_{OUT} = 2.6\text{ V}$	—	—	-200	μA
Low level output current 1	I_{OL1}	RMO, $V_{OUT} = 0.4\text{ V}$	400	—	—	μA
Low level output current 2	I_{OL2}	P_{01} to P_{03} , P_{30} to P_{33} , P_{40} , P_{41} , $V_{OUT} = 0.4\text{ V}$	1.0	—	—	mA
Schmitt hysteresis width	V_{WD}		—	1.0	—	V

* $\overline{\text{TEST}}$, $\overline{\text{RESET}}$, P_{01} to P_{03} , P_{10} , P_{11} , P_{20} to P_{22}

■ **Instructions**

1. Instructions are 16-bit length, and executed in a single instruction cycle (4 clocks).
2. The S-1462AF/14L62AF has 6 addressing modes.
 - 1) Direct addressing mode
 - 2) Relative addressing mode
 - 3) Immediate addressing mode
 - 4) Register addressing mode
 - 5) Accumulator indirect addressing mode
 - 6) Accumulator indexed addressing mode
3. Number of instructions

Table 8

	Basic	Including addressing modes
Transfer instruction	6	15
Arithmetic operation instruction	9	57
Logical operation instruction	8	66
Branch instruction	7	19
Rotate/shift instruction	2	6
CPU control instruction	3	3
Total	35	166

■ **Application Example (S-1462AF)**

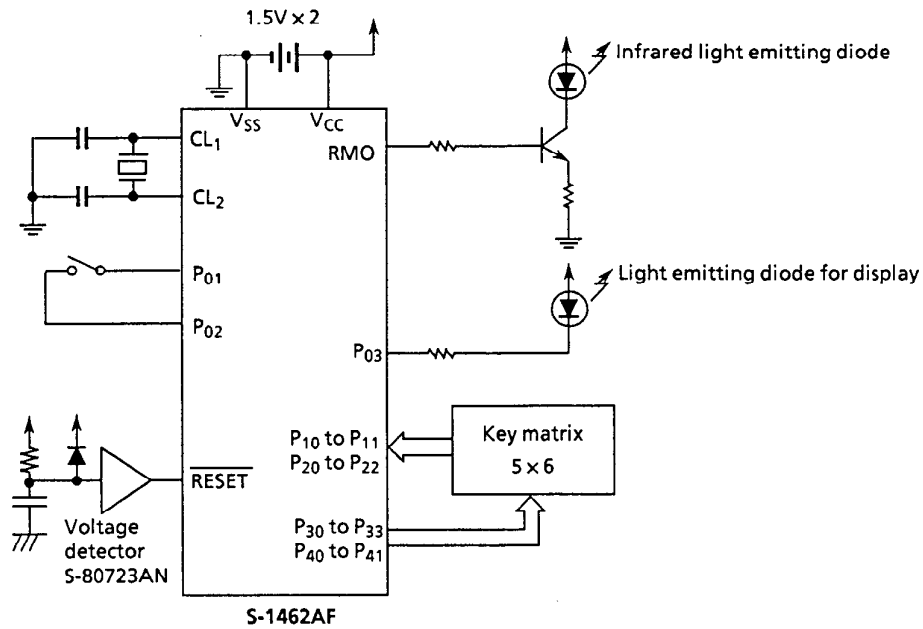

Figure 4