

# DATA SHEET

Part No.	AN12948A
Package Code No.	HQFP048-P-0707

---

## Contents

■ Overview .....	<a href="http://www.DataSheet4U.com">www.DataSheet4U.com</a> 3
■ Features .....	3
■ Applications .....	3
■ Package .....	3
■ Type .....	3
■ Block Diagram (Application Circuit Example) .....	4
■ Pin Descriptions .....	5
■ Absolute Maximum Ratings .....	7
■ Operating Supply Voltage Range .....	7

# AN12948A

## Audio Power IC for Note PC

www.DataSheet4U.com

### ■ Overview

AN12948A is the stereo BTL amplifier which contained the AGC circuit for clip prevention of a speaker output and headphone amplifier within charge pump.

This IC performs a mode change by parallel control system. (Standby function ON/OFF change etc.)

### ■ Features

- In order to realize high efficiency of output power, it adopts CMOS power amplifier circuit .
- Max. Power: 1.4 W (VCCSP = 5 V, RL = 8 Ω, THD = 10%)  
2.2 W (VCCSP = 5 V, RL = 4 Ω, THD = 10%)
- The resistance and the capacitor of a detector circuit which were being used for the conventional AGC.
- The filter circuit for the frequency response decision can be composed of the input circuit.
- Built-in direct drive headphone amplifier within charge pump.
- STBY function (countermeasure pop noise)  
The standby terminal of the speaker amplifier and the headphone amplifier is prepared by each of two terminals.  
When either of two terminals becomes "High", it is standby OFF.
- AGC ON/OFF function
- AGC ON Level select function
- AGC attack time select function
- AGC recovery time select function
- Cellular phone measures  
RF noise prevention
- Built-in over current protection

### ■ Applications

- For the notebook personal computer

### ■ Package

- 48-pin plastic quad flat package with heat slug (QFP type)

### ■ Type

- Silicon monolithic BI-CMOS IC

■ Block Diagram (Application Circuit Example)

www.DataSheet4U.com

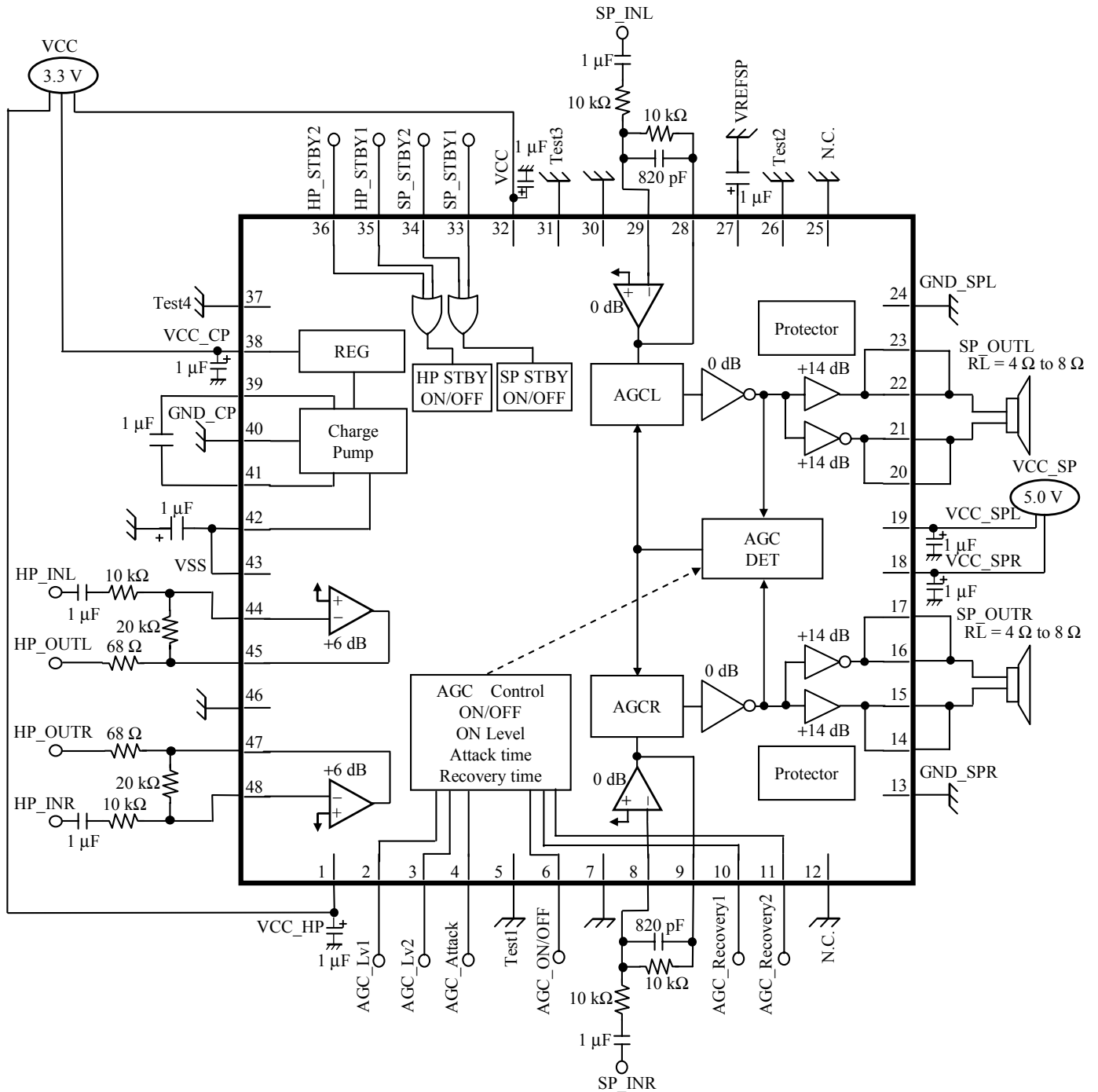

Note) This circuit and these circuit constants show an example and do not guarantee the design as a mass-production set.

## ■ Pin Descriptions

Pin No.	Pin name	Type	Description
1	VCC_HP	Power Supply	Power Supply for HP amp.
2	AGC_Lv1	Input	AGC-on-level selection
3	AGC_Lv2	Input	AGC-on-level selection
4	AGC_Attack	Input	AGC-attack-time selection
5	Test1	—	Terminal for testing (please connect to Ground)
6	AGC_ON/OFF	Input	AGC ON/OFF selection
7	GND	Ground	Ground
8	SP_INR	Input	The feedback terminal of SP input amp. R-channel
9	PREOUT_R	Output	The output terminal of SP input amp. R-channel
10	AGC_Recovery1	Input	AGC-recovery-time selection
11	AGC_Recovery2	Input	AGC-recovery-time selection
12	N.C.	—	N.C.
13	GND_SPR	Ground	Ground for SP R-channel amp system
14	SP_OUTR+	Output	SP amp. R-channel output (+)
15	SP_OUTR+	Output	SP amp. R-channel output (+)
16	SP_OUTR-	Output	SP amp. R-channel output (-)
17	SP_OUTR-	Output	SP amp. R-channel output (-)
18	VCC_SPR	Power supply	Power Supply for SP R-channel amp system
19	VCC_SPL	Power supply	Power Supply for SP L-channel amp system
20	SP_OUTL-	Output	SP amp. L-channel output (-)
21	SP_OUTL-	Output	SP amp. L-channel output (-)
22	SP_OUTL+	Output	SP amp. L-channel output (+)
23	SP_OUTL+	Output	SP amp. L-channel output (+)
24	GND_SPL	Ground	Ground for SP L-channel amp system
25	N.C.	—	N.C.
26	Test2	—	Terminal for testing (please connect to Ground)
27	VREFSP	Input	Terminal of reference voltage for SP amp.
28	PREOUT_L	Output	The output terminal of SP input amp. L-channel
29	SP_INL	Input	The feedback terminal of SP input amp. L-channel
30	GND	Ground	Ground
31	Test3	—	Terminal for testing (please connect to Ground)
32	VCC	Power Supply	Power Supply VCC

## ■ Pin Descriptions (continued)

Pin No.	Pin name	Type	Description
33	SP_STBY1	Input	SP Standby On/Off control
34	SP_STBY2	Input	SP Standby On/Off control
35	HP_STBY1	Input	HP Standby On/Off control
36	HP_STBY2	Input	HP Standby On/Off control
37	Test4	—	Terminal for testing (please connect to Ground)
38	VCC_CP	Power Supply	Power Supply for Charge pump
39	C1	Output	Capacitor Connect Terminal1 for Charge pump
40	GND_CP	Ground	Ground for Charge pump
41	C2	Output	Capacitor Connect Terminal2 for Charge pump
42	VSS_CP	Output	Charge pump output
43	VSS	Power supply	Negative Power Supply supplied from Charge pump
44	HP_INL	Input	The feedback terminal of HP amp. L-channel
45	HP_OUTL	Output	HP amp. L-channel output
46	GND	Ground	Ground
47	HP_OUTR	Output	HP amp. R-channel output
48	HP_INR	Input	The feedback terminal of HP amp. R-channel

### ■ Absolute Maximum Ratings

A No.	Parameter	Symbol	Rating	Unit	Note
1	Supply voltage	VCC VCC_HP VCC_CP	5.75	V	*1
		VCC_SPL VCC_SPR	5.75		
2	Supply current	I <sub>CC</sub>	—	A	
3	Power dissipation	P <sub>D</sub>	355	mW	*2
4	Operating ambient temperature	T <sub>opr</sub>	−30 to +75	°C	*3
5	Storage temperature	T <sub>stg</sub>	−55 to +150	°C	

Note) \*1: The values under the condition not exceeding the above absolute maximum ratings and the power dissipation.

\*2 : The power dissipation shown is the value at T<sub>a</sub> = 75°C for the independent (unmounted) IC package with a heat sink.

\*3 : Except for the power dissipation, operating ambient temperature, and storage temperature, all ratings are for T<sub>a</sub> = 25°C.

### ■ Operating Supply Voltage Range

Parameter	Symbol	Range	Unit	Note
Supply voltage range	VCC VCC_HP VCC_CP	3.0 to 5.5	V	*
	VCC_SPL VCC_SPR	4.5 to 5.5		

Note) \*: The values under the condition not exceeding the above absolute maximum ratings and the power dissipation.

## Request for your special attention and precautions in using the technical information and semiconductors described in this book

- (1) If any of the products or technical information described in this book is to be exported or provided to non-residents, the laws and regulations of the exporting country, especially, those with regard to security export control, must be observed.
- (2) The technical information described in this book is intended only to show the main characteristics and application circuit examples of the products, and no license is granted under any intellectual property right or other right owned by our company or any other company. Therefore, no responsibility is assumed by our company as to the infringement upon any such right owned by any other company which may arise as a result of the use of technical information described in this book.
- (3) The products described in this book are intended to be used for standard applications or general electronic equipment (such as office equipment, communications equipment, measuring instruments and household appliances).  
Consult our sales staff in advance for information on the following applications:
  - Special applications (such as for airplanes, aerospace, automobiles, traffic control equipment, combustion equipment, life support systems and safety devices) in which exceptional quality and reliability are required, or if the failure or malfunction of the products may directly jeopardize life or harm the human body.
  - Any applications other than the standard applications intended.
- (4) The products and product specifications described in this book are subject to change without notice for modification and/or improvement. At the final stage of your design, purchasing, or use of the products, therefore, ask for the most up-to-date Product Standards in advance to make sure that the latest specifications satisfy your requirements.
- (5) When designing your equipment, comply with the range of absolute maximum rating and the guaranteed operating conditions (operating power supply voltage and operating environment etc.). Especially, please be careful not to exceed the range of absolute maximum rating on the transient state, such as power-on, power-off and mode-switching. Otherwise, we will not be liable for any defect which may arise later in your equipment.
  - Even when the products are used within the guaranteed values, take into the consideration of incidence of break down and failure mode, possible to occur to semiconductor products. Measures on the systems such as redundant design, arresting the spread of fire or preventing glitch are recommended in order to prevent physical injury, fire, social damages, for example, by using the products.
- (6) Comply with the instructions for use in order to prevent breakdown and characteristics change due to external factors (ESD, EOS, thermal stress and mechanical stress) at the time of handling, mounting or at customer's process. When using products for which damp-proof packing is required, satisfy the conditions, such as shelf life and the elapsed time since first opening the packages.
- (7) This book may be not reprinted or reproduced whether wholly or partially, without the prior written permission of Matsushita Electric Industrial Co., Ltd.